

Substation Automation and Protection Division

REL 512 Setting Example for Medium and Long Lines

Transmission line lengths for protection application purposes are classified as short, medium and long. The definition is found in IEEE Std C37.113-1999. The length classification is defined by the ratio of the source impedance at the protected line's terminal to the protected line's impedance (SIR). SIR's of about 4 or greater generally define a short line. Medium lines are those with SIR's greater than 0.5 and less than 4. Long lines have SIR's less than 0.5.

For this settings example we will consider the system diagram of Figure 1 and the system data of Table 1. This REL 512 setting example deals with setting the relays on Line 2 controlling breaker # 3 at Bus E for two and three terminal line protection. All discussion and settings are based on two or three terminal except where specifically noted.

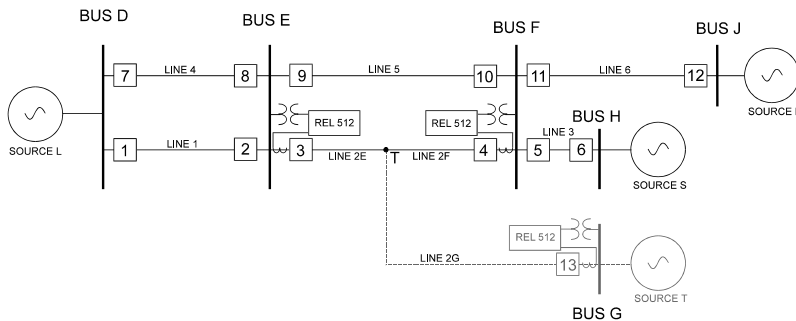

Figure 1 - 230 kV Setting Example System Single Line Diagram

Table 1 - System Data for 230kV Example System

System Element	Length	Primary Ohms				CT Ratio*3	VT Ratio
		Z ₁		Z ₀			
		Mag	Angle ⁰	Mag	Angle ⁰		
LINE 1	50	39	82	124	78	-	-
LINE 2E*1	40	31.2	84	99.8	76	1200:5 [1200:1]	2000:1
LINE 2F*1	60	46.8	84	149.7	76	1200:5 [1200:1]	2000:1
LINE 2G*2	70	54.6	84	174.65	76	2000:5 [2000:1]	2000:1
LINE 3	20	15.6	82	49.9	78	-	-
LINE 4	50	39	82	124	78	-	-
LINE 5	100	78	84	249.5	76	-	-
LINE 6	60	46.8	82	149.7	78	-	-
SOURCE L	-	3.8	88	6.0	80	-	-
SOURCE R	-	18.0	88	15.0	79	-	-
SOURCE S	-	7.2	87	19.3	76	-	-
SOURCE T	-	2.6	88	4.6	79	-	-

1. Use LINE 2E and 2F sum for a two terminal line application. The maximum load at Bus E and Bus F is 650 A. primary.

2. Use LINE 2G data for three terminal line applications. The maximum load at Bus E and Bus F is 650 A, and at Bus G is 1300 A. primary.

3. CT ratios are shown for 5 A and [1 A] secondary.

4. Substation bus arrangement is single breaker.

Configuration Settings

Enter the following configuration settings for the Bus E, Breaker # 3 relay

Setting	Value	Comments
STATION NAME	Bus E	Limited to 14 characters
BAY NAME	Breaker #3	Limited to 14 characters
LINE NAME	Line #2	Limited to 14 characters
GND DIR POL	3V2	Negative sequence polarization is preferred to eliminate the effect of zero sequence mutual coupling
EXT SET SELECT	DISABLE	External settings selector is not used
FRNT BIT RATE	115200	Match computer's comport settings and capability
FRNT DATA LGTH	8	Match computer's comport setting
FRNT PARITY	NONE	Match computer's comport setting
FRNT STOP BITS	2	Match computer's comport setting
REAR BIT RATE	19200	Match computer's comport settings and modem/switch capability
REAR DATA LGTH	8	Match computer's comport setting
REAR PARITY	NONE	Match computer's comport setting
REAR STOP BITS	2	Match computer's comport setting
Network Settings	---	Refer to DNP 3.0 or ModBus Plus Settings documentation
VT RATIO	2000	230 kV
CT RATIO	240 [1200]	1200/5 for 5 A CT. [1200/1 for 1 A CT.]
UNITS PRI/SEC	PRIMARY	This will display metering in primary values
DATA CAPTURE	PILOT	This is for capturing digital fault records when the line trips as well as when faults occur around the line within pilot zones
DATE	Current Date	Set manually via comport if IRIX is not used
TIME	Current Time	Set manually via comport if IRIX is not used

Three Terminal Application Considerations

The application of distance relays on three terminal line configurations is very complicated as there are possibilities of numerous variations. Rarely ever is it possible to have a simple stepped distance protection setting on such a line. Invariably pilot schemes are used to trip all the three terminal breakers immediately on fault, securely and dependably. It is thus mandatory to do a thorough application check for such a system.

The zone-1 settings are essential for PUTT schemes but can be used to improve the protection speed for other Pilot schemes. The settings are usually 90% of the line impedance to the nearest bus. This is the maximum setting possible on the line when operation is possible with no in-feed / breaker open condition. Another important aspect to be considered while deciding zone-1 reach is to check that there is no outfeed from any terminal for a line internal fault. This apparently makes zone-1 to overreach and make it operate for external faults. A very careful study of the system is essential. Usually a direct trip transfer scheme using zone-1 elements is often used. This also means that at least one end zone-1 shall see a fault anywhere along the line.

With three terminal line, the conventional zone-2 cannot always be set to cover the remote end buses at all times without overreaching into too many other system buses during light in-feed conditions. So often zone-2 is set just to cover the nearest bus of the three terminal system.

Zone-3 is set to cover the protected line and the longest adjoining line section with no infeed conditions at the remote buses.

Utilizing any pilot scheme . . . PUTT, POTT, Unblocking or Blocking, that utilizes forward-looking overreaching elements, it is essential to insure that the remote buses are always overreached for every infeed configuration. This is easily achievable with the REL 512 as the forward overreaching pilot zone is independent of zone-2 limitations, and is therefore not restricted in its reach setting.

Protection Settings

The following settings apply to the relay at Bus E controlling Breaker #3.

Source Impedance Ratio

The first step is to check for application limitations dictated by the SIR (source impedance ratio). The SIR affects the operating speed of the impedance units and is defined by the following equation where Z_S is the equivalent source impedance at the bus where the relay is applied and Z_R is the impedance reach setting on the relay.

$$SIR = \frac{Z_S}{Z_R}$$

The limitations, if any, may limit the application of zone-1 or may require increasing the reach of the forward overreaching zone used for pilot tripping to assure an acceptable operating speed. This generally applies only to very short lines.

The worst case (highest SIR) for this application would be with maximum source impedance, behind Bus E and source at S and R removed. The maximum source impedance behind Bus E is when there is a single circuit operation between buses D and E. It is computed for phase-to-phase and phase-to-ground faults with the following equation:

$$Z_{S_{\max}} = Z_{SL} + Z_{Line1}$$

Phase-to-phase Faults

$$Z_{S_{\max}} = 3.8e^{j88} + 39e^{j82} = 42.78e^{j83} \quad \text{Primary ohms}$$

The worst case of minimum voltage at the relaying point occurs when the parallel line is in service. Infeed from sources S and R would only increase the voltage measured at the relaying point and likewise reduce the SIR. Also, with the parallel line an effective SIR_E must be calculated.

The relay is to be set at 90% of the protected line. The impedance from Bus E to the 90% fault point on Line 2 is equal to 90% of Line 2 in parallel with 10% of Line 2 plus 100% of the parallel Line 5. This is computed as follows:

$$Z_{Ef} = \frac{70.2 * 85.8}{2 \times 78} e^{j84} = 38.61e^{j84} \quad \text{Equivalent impedance from Bus E to 90% fault on Line 2}$$

Using Z_{Ef} the maximum effective SIR_E at the relay for phase-to-phase faults is computed as:

$$SIR_E = \frac{Z_{S \max}}{Z_{Ef}} = \frac{42.78}{38.61} = 1.1$$

Reviewing the operating characteristics it is seen that this SIR will result in high speed performance and warrants no special settings consideration.

Phase-to-ground Faults

For calculating SIR for phase-to-ground faults, it is necessary to calculate the ground [fault] loop impedance. The ground loop impedance is given by the equation,

$$Z_G = \frac{2Z_1 + Z_0}{3}$$

where Z_1 and Z_0 are the positive and zero sequence impedances of the concerned power system element.

The maximum ground loop source impedance is

$$Z_{GS \max} = \frac{2 \times (3.8e^{j88} + 39e^{j82}) + 6e^{j80} + 124e^{j78}}{3} = 71.8e^{j80} \text{ Primary ohms}$$

The zero sequence impedance in front of the relay is 90% of Line 2 in parallel with 10% of Line 2 plus 100% of the parallel Line 5.

$$Z_{0Ef} = \frac{224.55 * 274.45}{2 \times 249.5} e^{j78} = 123.5e^{j78} \text{ Equivalent zero sequence impedance from Bus E to 90\% fault on Line 2}$$

Then using the equivalent positive and zero sequence impedances, the equivalent ground loop impedance is computed,

$$Z_{GEf} = \frac{2 \times 38.61e^{j84} + 123.5e^{j78}}{3} = 66.8e^{j80} \text{ Equivalent ground loop impedance in primary ohms}$$

The effective SIR_{GE} is,

$$SIR_{GE} = \frac{Z_{GS \max}}{Z_{GEf}} = \frac{71.8}{66.8} = 1.08$$

The effective SIR's as calculated will determine the accuracy and speed with which Zone-1 element operates. Typically if SIR is less than 10, zone-1 may be applied. If greater than 10 the application of zone-1 should be reviewed.

Also to be noted is that the protected line is by definition of medium length although it is 100 miles long. A line that just 5 miles long may also be considered medium length if it meets the above definition. Such systems have higher fault current levels.

Zone-1 Settings

Setting	Value	Comments and Calculations
Z1 K0 MAG Z1 K0 ANG	2.21 -12	<p>Compute the zero sequence compensation factor K_0. For two terminal line applications the total positive and zero sequence ohms of line segments 2E and 2F are $Z_1 = 78e^{j84}$ ohms and $Z_0 = 249.5e^{j76}$ ohms. Use the following equation:</p> $K_0 = \frac{Z_0}{Z_1} - 1$ $K_0 = \frac{249.5e^{j76}}{78e^{j84}} - 1$ $K_0 = 3.2e^{-j8} - 1$ $K_0 = 3.169 - 1 - j0.445$ $K_0 = 2.214e^{-j11.6}$ <p>Round-off the angle to the nearest degree (integer)</p>
Z1 LINE ANGLE	84	Use the Positive sequence impedance angle of Line 2
Z1 PH REACH	8.42 [42.1]	<p>The zone-1 phase reach for this application will be set for 90% of Line 2EF length and is set in secondary ohms (Z_{1S}). It is computed with the following equation:</p> $Z_{1S} = 0.9Z_1 \frac{CT}{VT}$ $Z_{1S} = 0.9(78) \frac{240}{2000}$ $Z_{1S} = 8.42[42.1]$ <p>For three terminal line protection the setting will be 90% of the positive sequence Line 2EF impedance, which is the shortest length to a remote bus.</p>
Z1 PH TRIP	ENABLE	Set to ENABLE to allow zone-1 tripping for multi-phase faults
Z1 GND REACH	8.42 [42.1]	<p>The ground impedance reach is typically set the same as the phase reach unless there is a grounding transformer on the protected line, significant mutual impedance with a parallel line, or other special application needs.</p> <p>Refer to Settings and Application Guide for details.</p>
Z1 GND TRIP	ENABLE	Set to ENABLE to allow zone-1 tripping for single line-to-ground faults with the cross-polarized mho units.
Z1 GND BULLET	DISABLE	Ground quadrilateral protection may be beneficial for non-pilot step distance schemes. They generally provide no useful purpose for pilot schemes utilizing ground directional overcurrent in the pilot scheme. Also, they are not required on medium and long lines. Set to ENABLE to allow tripping with the zone-1 ground quadrilateral unit.
Z1 RESISTANCE	-	Applies only if Z1 GND BULLET is enabled.
Z1 OS BLOCK	ENABLE	Setting to ENABLE will block zone-1 for power swings that may be seen by zone-1. The OS TYPE setting must be set to OS BLOCK or OS TRIP for zone-1 blocking.
Z1 RECL INIT	HIGH SPEED	The setting HIGH SPEED is only used for pilot applications assuring high-speed tripping at all line terminals. It is generally used to initiate high-speed reclosing without voltage and synchronism checks.
Z1 RI FLT TYPE	ALL FAULTS	Three-phase fault duty is approximately 6000 A. primary at Bus E and is not severe enough to limit high-speed reclosing of Breaker 3.
Z1 TD FAULTS	DISABLE	Since high-speed reclosing will occur for all faults this setting should be disabled.

Zone-2 Settings

Setting	Value	Comments and Calculations
Z2 K0 MAG Z2 K0 ANG	2.21 -12	This is set using the sequence impedance quantities of the total circuit (Line 2 + X% of Line 3) for which zone-2 is expected to operate. Generally the values computed for zone-1 are used unless there is a significant difference Line 2 and Line 3 sequence impedance quantities.
Z2 LINE ANGLE	84	This is set using the positive sequence impedance angle of the total circuit (Line 2 + X% of Line 3) for which zone-2 is expected to operate. Generally the value computed for zone-1 is used unless there is a significant difference Line 2 and Line 3 positive sequence impedance angles.
Z2 PH REACH	10.76 [53.8]	<p>The zone-2 phase reach for this application should be set to overreach the remote Bus F and, if possible, not overreach the far bus of the shortest adjacent line, in this case Bus H and Line 3. Line 3 impedance is 20% of Line 2's impedance. This sets up a rather tight coordination. The relay's zone-2 unit can easily be set to see faults on Bus F. For faults at Bus H the relay's zone-2 unit will underreach (not see it) except for cases where Source R is not available and possibly for cases where the parallel line is out and grounded. An alternate setting may be desired. Given the REL 512 inverse characteristic, setting very close to the line length is permissible. In this case a factor of 1.15 times Line 2 impedance is used.</p> $Z_{2S} = 1.15 Z_{Line2} \frac{CT}{VT}$ $Z_{2S} = 1.15(78) \frac{240}{2000}$ $Z_{2S} = 10.76[53.8]$ <p>A fault study will show that the zone-2 reach cannot be set to overreach Bus F if the third terminal at Bus G is in service. Therefore, with the pilot scheme disabled, zone-2 operation for remote faults will only occur after the non-faulted remote terminal clears. If zone-2 cannot operate then zone-3 or time-overcurrent backup (TD 51P) will be depended on for operation. Increasing the setting is not recommended.</p>
Z2 PH DLY	.25	A zone-2 setting of 0.25 second and zone-3 setting of 0.5 second is adopted throughout the utility system. Set these values for two-terminal applications. Stepped distance zone coordination is not possible for the three terminal line applications where sequential or other backup tripping is required. Set timers the same as for two-terminal applications.
Z2 PH TRIP	ENABLE	Set to ENABLE to allow zone-2 tripping for multi-phase faults
Z2 GND REACH	10.76 [53.8]	Set the same as Z2 PH REACH. The mutual impedance effects also need to be considered here to assure overreaching Bus F.
Z2 GND DLY	.25	Refer to Z2 PH DLY
Z2 GND TRIP	ENABLE	Set to ENABLE to allow zone-2 tripping for single line-to-ground faults with the cross-polarized mho units.
Z2 OS BLOCK	ENABLE	Setting to ENABLE will block zone-2 for power swings that may be seen. The OS TYPE setting must be set to OS BLOCK or OS TRIP for zone-2 blocking.

Z2 RECL INIT	ENABLE	The setting ENABLE provides for a time delayed reclose initiate output. It is generally used to initiate reclosing with voltage and/or synchronism checks.
--------------	--------	--

Zone-3 Settings

Setting	Value	Comments and Calculations
Z3 K0 MAG Z3 K0 ANG	2.21 -12	This is set using the sequence impedance quantities of the total circuit [1.2x(Line 2 + Line 6)] for which zone-3 is expected to operate. Generally the values computed for zone-1 are used unless there is a significant difference Line 2 and Line 6 sequence impedance quantities.
Z3 LINE ANGLE	84	This is set using the positive sequence impedance angle of the total circuit [1.2x(Line 2 + Line 6)] for which zone-3 is expected to operate. Generally the value computed for zone-1 is used unless there is a significant difference Line 2 and Line 6 positive sequence impedance angles.
Z3 PH REACH	18.0 [90.0]	<p>The zone-3 phase reach for this application should be set to overreach the remote bus of the longest adjacent line. In this case Bus J and Line 6. Line 6 impedance is 60% of Line 2's impedance.</p> $Z_{3S} = 1.2(Z_{Line2} + Z_{Line6}) \frac{CT}{VT}$ $Z_{3S} = 1.2(1.6)(78) \frac{240}{2000}$ $Z_{3S} = 17.8[89.0]$ <p>In this case this setting will be sufficient to backup zone-2 for three terminal line applications and assure complete line coverage. It will also cover Line 3, but will not cover Line 6. Zone-3 would have to be set to 30 ohms to achieve this. These results are determined by fault study and computing the Bus E voltage and Line 2 current for fault locations at Buses F, H and J.</p>
Z3 PH DLY	.5	A zone-2 setting of 0.25 second and zone-3 setting of 0.5 second is adopted throughout the utility system. Refer to Z2 PH DLY.
Z3 PH TRIP	ENABLE	Set to ENABLE to allow zone-3 tripping for multi-phase faults
Z3 GND REACH	18.0 [90.0]	The ground impedance reach is typically set the same as the phase reach.
Z3 GND DLY	.5	Refer to Z2 PH DLY.
Z3 GND TRIP	ENABLE	Set to ENABLE to allow zone-3 tripping for single line-to-ground faults with the cross-polarized mho units.
Z3 OS BLOCK	ENABLE	Setting to ENABLE will block zone-3 for power swings that may be seen. The OS TYPE setting must be set to OS BLOCK or OS TRIP for zone-3 blocking.
Z3 RECL INIT	ENABLE	The setting ENABLE provides for a time delayed reclose initiate output. It is generally used to initiate reclosing with voltage and/or synchronism checks.

Forward Pilot Zone Settings

The forward pilot zone is generally used only for pilot applications and is set completely independent of the non-pilot step distance zones 1, 2 and 3.

Setting	Value	Comments and Calculations
FWP K0 MAG FWP K0 ANG	2.21 -12	This is set using the sequence impedance quantities of the total circuit (Line 2 + X% of Line 3) for which the FWP zone is expected to operate. Generally the values computed for zone-1 are used unless there is a significant difference Line 2 and Line 3 sequence impedance quantities.
FWP LINE ANGLE	84	This is set using the positive sequence impedance angle of the total circuit (Line 2 + X% of Line 3) for which the FWP zone is expected to operate. Generally the value computed for zone-1 is used unless there is a significant difference Line 2 and Line 3 positive sequence impedance angles
FWP PH REACH	14.0 [70.0] Three Terminal 20.0 [100.0]	This zone can be set to reach in the forward direction and maintain security without limitation except for BLOCKING applications. The reach of this zone for BLOCKING will affect the exposure to undesired operations during loss of channel conditions. For medium and long lines the reach should be set to overreach zone-2. Typically 150% of the protected line is appropriate. $Z_{2S} = 1.5 Z_{Line2} \frac{CT}{VT}$ $Z_{2S} = 1.5(78) \frac{240}{2000}$ $Z_{2S} = 14.04 [70]$ <p>Fault analysis shows that for three terminal line application with Bus G in service and Line 4 out, the secondary fault impedance measured by this relay will be 16.6 ohms for a fault at Bus F. To assure overreaching for all conditions it is recommended to set this reach to $1.2 \times 16.6 = 20$ ohms.</p>
FWP PH DLY	0.5	This delay time is used only if FWP PH TRIP is enabled.
FWP PH TRIP	DISABLE	DISABLE is the normal setting for pilot applications. However this unit can be set to ENABLE to allow time delayed FWP zone non-pilot tripping for special applications.
FWP GND REACH	14.0 [70.0] Three Terminal 20.0 [100.0]	The ground impedance reach is typically set the same as the phase reach unless there is a grounding transformer on the protected line or other special application. Fault analysis for the ground impedance setting show similar results.
FWP GND DLY	0.5	This delay time is used only if FWP GND TRIP is enabled.
FWP GND TRIP	DISABLE	DISABLE is the normal setting for pilot applications. However this unit can be set to ENABLE to allow time delayed FWP zone non-pilot tripping for special applications.
FWP OS BLOCK	ENABLE	Setting to ENABLE will block the FWP zone for power swings that may be seen. The OS TYPE setting must be set to OS BLOCK or OS TRIP for FWP zone blocking.

PHASE SELECTION FACTOR	1.54	<p>The PHASE SELECTION FACTOR times FWP GND REACH defines the reach of the phase selection zone. Operation of two of these units would indicate a two-phase-to-ground faults and hence phase-ground zone-1 and forward pilot zone phase-to-ground elements are blocked. To keep the phase selector reach as high as possible</p> $\text{PHASE_SELECTION_FACTOR} = \frac{36[180]}{(1 + K_0/3) \text{FWPGNDREACH}}$ $\text{PHASE_SELECTION_FACTOR} = \frac{36[180]}{(1 + 2\angle -12/3) 14.0[70.0]}$ <p>PHASE_SELECTION_FACTOR ≈ 1.54</p>
------------------------	------	---

Reverse Pilot Zone Settings

This function serves as a supplement to the FWP (forward pilot) zone. This zone is essential for BLOCKING schemes as a carrier start function, and for POTT and unblocking applications serves the purpose of transient blocking function when parallel lines are involved. Also the RVP zone defines DFR (digital fault recording) coverage in the reverse direction.

Setting	Value	Comments and Calculations
RVP K0 MAG RVP K0 ANG	2.21 -12	These settings should be the same settings used for FWP K0 MAG and FWP K0 ANG as set on the remote relaying terminal(s).
RVP LINE ANGLE	84	These settings should be the same settings used for FWP K0 MAG and FWP K0 ANG as set on the remote relaying terminal(s).
RVP PH REACH	7.0 [35.0] Three Terminal 10.0 [50.0]	This zone is usually set at 50 to 70% (or more) of the setting of the remote FWP PH REACH. For BLOCKING schemes this zone must see all reverse faults seen by the remote FWP PH REACH. Since the remote FWP PH REACH is set to 150% of Line 2 it is recommended to set this zone to at least 50% of the remote FWP PH REACH. (0.5 x 14.0 = 7.0) [0.5 x 70 = 35] For PUTT schemes the RVP zone serves no useful purpose and hence may be set to limit DFR coverage.
RVP PH DLY	0.15	This delay time is used only if RVP PH TRIP is enabled. For backup bus applications it should be set to operate before a remote zone-2.
RVP PH TRIP	DISABLE	DISABLE is the normal setting for pilot applications. However this unit can be set to ENABLE to allow time delayed RVP zone tripping for special applications such as backup bus protection.
RVP GND REACH	7.0[35.0] Three Terminal 10.0 [50.0]	The ground impedance reach is typically set the same as the phase reach unless there is a grounding transformer on the protected line or other special application needs.
RVP GND DLY	0.15	This delay time is used only if RVP GND TRIP is enabled. For backup bus applications it should be set to operate before a remote zone-2.
RVP GND TRIP	DISABLE	DISABLE is the normal setting for pilot applications. However this unit can be set to ENABLE to allow time delayed RVP zone non-pilot tripping for special applications.

Line Characteristics

These settings are provided to accurately compute fault location in miles or kilometers. The impedance of Line 2 is $78e^{j84}$ and the length is 100 miles. For three terminal applications the fault location will only be accurate for faults up to the three terminal line connection point. Use only the respective line section to compute ohms/mile.

Setting	Value	Comments and Calculations
LN LGTH UNITS	MILES	Line length is given in miles.
LN R PU	.0098 [.0490]	$R = \frac{78}{100} \times \frac{240}{2000} \times \cos(84^\circ) = 0.0098 \text{ resistive sec. ohms/mile}$ Round to nearest 1/10000 (4 places). Use 31.2/40 ohms/mile up to the three terminal connection for three terminal line applications.
LN X PU	.0931 [.4655]	$X = \frac{78}{100} \times \frac{240}{2000} \times \sin(84^\circ) = 0.0931 \text{ reactive sec. ohms/mile}$ Round to nearest 1/10000 (4 places). Use 31.2/40 ohms/mile up to the three terminal connection for three terminal line applications.

Out-of-step and Load Restriction

Setting	Value	Comments and Calculations
LD RESTRICTION	ENABLED	These settings should be enabled if maximum loads may cause any impedance unit operation. Zone-3 is generally the most affected.
OS TYPE	OS TRIP	Apply OS TRIP only if Breaker 3 will be one of the separation points between the two partial systems defined by Source L to Bus E and Bus F to Sources R and S. Apply OS BLOCK if the system separation is else where.
OST TIME 1	.02	The outer blinder has operated and a swing condition is established. This timer is to insure that more than a momentary operation of the inner blinder has occurred before committing to an out-of-step trip. The timer should be set for at least 0.02 seconds.
OST TIME 2	.02	This timer insures that for 'tripping' on the 'way-out' that adequate time has elapsed between inner and outer blinder resets. The recommended time is 0.02 seconds.
OST RESET TIME	.05	This is the reset time associated with OS TRP TM1 and OS TRP TM2. It must persist for a period of time sufficiently long to commit the 20/500 ms timer to operation for 'way-out' tripping. The recommended setting is 0.05 seconds.
OST WAY IN OUT	WAY OUT	Select WAY OUT to minimize OS tripping stress on Breaker 3.
OS OVRD TM	0.4	The out-of-step override timer releases the out-of-step function in the event an apparently slow moving impedance swing is actually an internal three phase fault.
BLINDER ANG	84	The blinder angle is set the same as the Z1 LINE ANG in most applications.

BLNDR INNER R	2.84 [14.2]	<p>From the instruction manual of REL512, Page 4.18, the inner blinder is to be set at $0.2Z_T$ where Z_T is the total protected line positive sequence impedance plus the sum of the <u>lowest</u> positive sequence source impedances at each end of the line. The critical issue here is that you must allow recoverable swings to occur before setting the OS block or trip function. Consider only the single circuit impedance between Bus E and Bus F.</p> <p>The minimum source impedance at bus E is $23.28e^{j83}$ ohms. The minimum source impedance at bus F is $16.85e^{j84}$ ohms. The impedance between Bus E and F is $78e^{j84}$.</p> $21BI = .2 \times (23.28 + 78 + 16.85) \times \frac{CT}{VT} = 2.84 \text{ secondary ohms}$ <p>The result should be greater than 0.1 times the maximum zone impedance setting, zone-3 in this case. Also, increasing the setting is permissible up to $0.288 Z_T$ before you affect the definition of (reduce below 120°) the critical swing angle. This is not required in this case.</p>
BLNDE OUTER R	4.84 [24.2]	$21BO = 21BI + 2 = 4.84$ secondary ohms

High Set Instantaneous Overcurrent Tripping Units

Setting	Value	Comments and Calculations
HS 50P PU	18.5 [3.69]	<p>A fault study shows that the maximum fault current in Line 2 through Breaker 3 for a three-phase fault on the line side of Breaker 3 is 7250 A primary (30.2 A secondary). For a three-phase fault at Bus F the Line 2 current is 1121 A primary. A margin of 1.3 or more is recommended to account for fault study and other error. This approach may not account for possible power swings. If tripping for power swings is to be avoided under the most extreme condition where both sources are 180° out of phase ($I = 2 \times V_{LG} / Z_{Line}$) the following rule may be implemented using the impedance of Line 2.</p> $I_{50P} = 1.3 \times \frac{2 \times 230000 / \sqrt{3}}{78 \times 240} = 18.44 [3.69]$
PU	5.3 [1.06]	<p>Fault study quantities may be used as shown above to determine this setting. A very safe approach would be to use the following formula:</p> $I_{50G} = 1.3 \times \frac{230000 / \sqrt{3}}{CT(2Z_1 + Z_0) / 3}$ $I_{50G} = 1.3 \times \frac{132790.6}{240(2 \times 78e^{j84} + 249.5e^{j76}) / 3} = 5.3 [1.06]$

HS 50Q PU	14 [2.8]	<p>A fault study shows that the maximum $3I_2$ current in Line 2 through Breaker 3 for a phase-to-phase fault on the line side of Breaker 3 is 8549 A primary (35.6 A secondary). For a phase-to-phase fault at Bus F the Line 2 $3I_2$ current is 1599 A primary (6.67 A secondary). A margin of 1.3 or more is recommended to account for fault study and other error. Using this approach depends on the confidence of the fault study.</p> <p>A more conservative approach is to assume an infinite source at Bus E. The negative sequence current in Line 2 for a phase-to-phase fault at Bus F is calculated by,</p> $I_2 = \frac{230000/\sqrt{3}}{2Z_1} \text{ primary Amps}$ <p>The relay, however, measures $3I_2$. Considering this, a very safe approach would be to use the following formula:</p> $I_{50Q} = 1.3 \times \frac{230000 \times \sqrt{3}}{CT \times 2Z_1}$ $I_{50Q} = 1.3 \times \frac{398371.7}{240 \times 2 \times 78} = 13.8[2.76]$
HS 50P TRIP	ENABLE	Set to ENABLE if 50P tripping is to be applied.
HS 50P DIR	ENABLE	Set to ENABLE for forward directional supervision of the 50P unit.
HS 50N TRIP	ENABLE	Set to ENABLE if 50N tripping is to be applied.
HS 50N DIR	ENABLE	Set to ENABLE for forward directional supervision of the 50N unit.
HS 50Q TRIP	ENABLE	Set to ENABLE if 50Q tripping is to be applied.
HS 50Q DIR	ENABLE	Set to ENABLE for forward directional supervision of the 50Q unit.
HS 50 RI	HIGH SPEED	The setting HIGH SPEED is only used with pilot applications assuring high-speed tripping at all line terminals. It is generally used to initiate high-speed reclosing without voltage and synchronism checks.
HS RI FLT TYPE	ALL FAULTS	Three-phase fault duty is approximately 6000 A. primary at Bus E and is not severe enough to limit high-speed reclosing of Breaker 3.
HS TD FAULTS	DISABLE	Since high-speed reclosing will occur for all faults this setting should be disabled.

Medium Set Instantaneous Overcurrent Units

Setting	Value	Comments and Calculations
MS 50P PU	3 [0.6]	<p>The maximum load current is 650 A primary. The minimum three-phase fault current is 1100 A primary. Both need to be considered when setting this unit. In this case set with a 10% margin above maximum load current.</p> $I_{50P} = 1.1 \times \frac{650}{240} = 2.98[0.6]$

MS 50 N PU	1.0 [0.2]	<p>The setting depends on the maximum unbalanced loads or, it depends on the current levels when switching tapped loads with pole spans greater than 8 ms. There are no tapped loads for this application.</p> <p>For solidly grounded systems a setting of 20% should usually provide adequate sensitivity. So, for a CT secondary rating of 5A [1A], a setting of 1A [0.2] is usually considered.</p> <p>Also, for BLOCKING pilot systems this unit must be coordinated with the remote LS 50N PU set such that the remote unit will operate for all faults for which this unit will operate.</p>
MS 50Q PU	1.0 [0.2]	Same as above except not used for pilot.
MS 50N TRIP	ENABLE	<p>This is enabled if pilot operation with the forward directional ground overcurrent (residual) units is desired. For non-pilot operations it is enabled if a definite time backup ground overcurrent function is applied.</p> <p>Note for all firmware versions up to and including V2.09: If the pilot system is disabled with the 85CO input then this setting should be disabled unless adequate coordination time with MS 50N DLY is used.</p>
MS 50N DLY	0.15 (BLOCKING) 0.00 (all others)	For pilot applications this can be set to 0 except for BLOCKING schemes. In the event of loss of pilot channel a minimum time delay should be applied to allow the remote faulted line's protection to operate. A setting of .15 (9 cycles) is probably suitable. This unit is for detecting high resistance ground faults and operates in parallel with the FWP zone.
MS 50Q TRIP	DISABLE	For non-pilot operations it is enabled if a definite time negative sequence backup overcurrent function is applied.
MS 50Q DLY	ENABLE	Set to ENABLE for forward directional supervision of the 50Q unit.

Low Set Instantaneous Overcurrent Units

Setting	Value	Comments and Calculations
LS 50P PU	1.0 [0.2]	This is set to indicate the presence of phase current. Typically a setting of 20% or lower is usually applied. So, for a CT secondary rating of 5A [1A], a setting of 1A [0.2] is considered.
LS 50 N PU	0.5 [0.1]	<p>The setting depends on the maximum unbalanced loads. It should be set at maximum sensitivity if possible. So, for a CT secondary rating of 5A [1A], a setting of 0.5A [0.1] is usually considered.</p> <p>Also, for BLOCKING pilot systems this unit must be coordinated with the remote MS 50N PU set such that this unit will operate for all faults for which the remote MS 50N unit will operate.</p>

Time Overcurrent Units

The time overcurrent units provide additional remote backup and can be 'torque controlled' by zone-2 or forward or reverse directional units. These units need to be coordinated with the operation of the appropriate adjacent line's protection. Refer to IB 40-512, Section 4 for additional application information.

Setting	Value	Comments and Calculations
TD 51P	DISABLE	Not used for this application.
TD 51Q	DISABLE	Not used for this application.
TD 51N	ENABLE	Enable if ground time overcurrent is as remote backup.
TD 51N PU	1.0 [0.2]	Set the value at which the unit picks up and start timing.
TD 51N A VALUE	29.239	This value is selected to produce a very inverse (CO-8) time overcurrent characteristic. Refer to Table 4-1 of IB 40-512.
TD 51N A VALUE	29.239	These values are selected to produce a very inverse (CO-8) time overcurrent characteristic. Refer to Table 4-1 of IB 40-512.
TD 51N B VALUE	0.827	
TD 51N P VALUE	2	
TD 51N TD VALUE	5	Use the appropriate time dial setting
TD 51N TR VALUE	0	Set 0 unless coordinating with the mechanical reset of E/M relays is required.
TD 51N CONTROL	FORWARD	Set to FORWARD to restrict operation to the forward direction.

Other Overcurrent Functions

Setting	Value	Comments and Calculations
CIFT	ENABLE	If the Voltage transformers are on the line side this is set 'ENABLE'. In cases when VT's are on the bus side, this shall be set to DISABLE. Line side VT's are assumed.
CIFT TM DLY	DISABLE	This is required when a single breaker controls two lines (single breaker substations) with respective protections for each line, but with common VT. This is not applicable in our case.
STUB BUS TRIP	DISABLE	Typically, in breaker-and-a-half bus schemes, this is set to clear faults instantly in the stub between the breaker (line CT) and the open line disconnect switch, with line VT on the line side of the switch. Usually this is set DISABLE, unless the isolator auxiliary contact 89b is wired to the protection.
TD 51 RI	DISABLE	This is normally set to disable unless it is desires to reclose on a 51 time overcurrent trip.

Voltage Elements and Logic Functions

Setting	Value	Comments and Calculations
UV PH PU	60	This should be set below the minimum system phase to neutral voltage expected. With a specified maximum dip of 5% expected of the system voltage at 230kV level, a setting of 60V secondary phase neutral voltage (max possible) is recommended for this setting.

System Type Logic

POTT

Use the following settings if a permissive overreaching transfer-trip scheme is to be applied.

Setting	Value	Comments and Calculations
SYSTEM TYPE	PILOT SYSTEM	The 230 kV scheme is POTT pilot.
STEP DISTANCE	3 ZONE	Use default if pilot is disabled.
PILOT SCHEME	POTT	The 230 kV scheme is POTT pilot.
POTT 3 TERM LN	DISABLE	Set to DISABLE for 2 terminal and ENABLE for 3 terminal applications
POTT WEAKFEED	DISABLE	This terminal is not weak feed.
PUTT 3 TERM LN	DISABLE	NA
UNBLK 3 TERM LN	DISABLE	NA
UNBLK WEAKFEED	DISABLE	NA
CHAN COORD TM	0.0	NA
RCV PULSE STR	0.0	NA
PS RECL INIT	HIGH SPEED	The setting HIGH SPEED is only used with pilot applications assuring high-speed tripping at all line terminals. It is generally used to initiate high-speed reclosing without voltage and synchronism checks.
PS RI FLT TYPE	ALL FAULTS	Three-phase fault duty is approximately 6000 A. primary at Bus E and is not severe enough to limit high-speed reclosing of Breaker 3.
PS TD FAULTS	DISABLE	Since high-speed reclosing will occur for all faults this setting should be disabled.
PS SLOW CLR RB	ENABLE	Reclosing will be blocked if the signal PILOT PH OR GND (forward fault) is asserted for 8 cycles before fault clearing. This assumes a breaker failure condition and will block reclosing.

PUTT

Use the following settings if a permissive underreaching transfer-trip scheme is to be applied.

Setting	Value	Comments and Calculations
SYSTEM TYPE	PILOT SYSTEM	The 230 kV scheme is PUTT pilot.
STEP DISTANCE	3 ZONE	Use default if pilot is disabled.
PILOT SCHEME	PUTT	The 230 kV scheme is PUTT pilot.
POTT 3 TERM LN	DISABLE	NA.
POTT WEAKFEED	DISABLE	NA
PUTT 3 TERM LN	DISABLE	Set to DISABLE for 2 terminal and ENABLE for 3 terminal applications.
UNBLK 3 TERM LN	DISABLE	NA
UNBLK WEAKFEED	DISABLE	NA
CHAN COORD TM	0.0	NA
RCV PULSE STR	0.0	NA
PS RECL INIT	HIGH SPEED	The setting HIGH SPEED is only used with pilot applications assuring high-speed tripping at all line terminals. It is generally used to initiate high-speed reclosing without voltage and synchronism checks.
PS RI FLT TYPE	ALL FAULTS	Three-phase fault duty is approximately 6000 A. primary at Bus E and is not severe enough to limit high-speed reclosing of Breaker 3.
PS TD FAULTS	DISABLE	Since high-speed reclosing will occur for all faults this setting should be disabled.
PS SLOW CLR RB	ENABLE	Reclosing will be blocked if the signal PILOT PH OR GND (forward fault) is asserted for 8 cycles before fault clearing. This assumes a breaker failure condition and will block reclosing.

BLOCKING

Use the following settings if a directional comparison blocking scheme is to be applied.

Setting	Value	Comments and Calculations
SYSTEM TYPE	PILOT SYSTEM	The 230 kV scheme is DCB pilot.
STEP DISTANCE	3 ZONE	Use default if pilot is disabled.
PILOT SCHEME	BLOCKING	The 230 kV scheme is DCB pilot.
POTT 3 TERM LN	DISABLE	NA.
POTT WEAKFEED	DISABLE	NA
PUTT 3 TERM LN	DISABLE	NA.
UNBLK 3 TERM LN	DISABLE	NA
UNBLK WEAKFEED	DISABLE	NA
CHAN COORD TM	0.012	Set to 12 ms with REL 512 at remote end
RCV PULSE STR	0.004	Set to 4 ms to prevent tripping for momentary (2 to 3 ms) loss of blocking carrier signals

PS RECL INIT	HIGH SPEED	The setting HIGH SPEED is only used with pilot applications assuring high-speed tripping at all line terminals. It is generally used to initiate high-speed reclosing without voltage and synchronism checks.
PS RI FLT TYPE	ALL FAULTS	Three-phase fault duty is approximately 6000 A. primary at Bus E and is not severe enough to limit high-speed reclosing of Breaker 3.
PS TD FAULTS	DISABLE	Since high-speed reclosing will occur for all faults this setting should be disabled.
PS SLOW CLR RB	ENABLE	Reclosing will be blocked if the signal PILOT PH OR GND (forward fault) is asserted for 8 cycles before fault clearing. This assumes a breaker failure condition and will block reclosing.

UNBLOCKING

Use the following settings if a directional comparison unblocking scheme is to be applied.

Setting	Value	Comments and Calculations
SYSTEM TYPE	PILOT SYSTEM	The 230 kV scheme is DCUB pilot.
STEP DISTANCE	3 ZONE	Use default if pilot is disabled.
PILOT SCHEME	BLOCKING	The 230 kV scheme is DCUB pilot.
POTT 3 TERM LN	DISABLE	Set to DISABLE for 2 terminal and ENABLE for 3 terminal applications
POTT WEAKFEED	DISABLE	This terminal is not weak feed.
PUTT 3 TERM LN	DISABLE	NA.
UNBLK 3 TERM LN	DISABLE	NA
UNBLK WEAKFEED	DISABLE	NA
CHAN COORD TM	0.0	NA
RCV PULSE STR	0.0	NA
PS RECL INIT	HIGH SPEED	The setting HIGH SPEED is only used with pilot applications assuring high-speed tripping at all line terminals. It is generally used to initiate high-speed reclosing without voltage and synchronism checks.
PS RI FLT TYPE	ALL FAULTS	Three-phase fault duty is approximately 6000 A. primary at Bus E and is not severe enough to limit high-speed reclosing of Breaker 3.
PS TD FAULTS	DISABLE	Since high-speed reclosing will occur for all faults this setting should be disabled.
PS SLOW CLR RB	ENABLE	Reclosing will be blocked if the signal PILOT PH OR GND (forward fault) is asserted for 8 cycles before fault clearing. This assumes a breaker failure condition and will block reclosing.

Trip Type

Three Pole Tripping

Use the following settings for three pole tripping.

Setting	Value	Comments and Calculations
TRIP TYPE	3 POLE TRIP	Three pole tripping will be used in this application.
SP 62TRP TMR	1.0	NA
SP TRIP TMR	1.0	NA
SP RECL INIT	SINGLE POLE	NA
SPT BKR2 OUT	DISABLE	Three extra three pole trip outputs are not required for this application.

Single Pole Tripping

Use the following settings for single pole tripping.

Setting	Value	Comments and Calculations
TRIP TYPE	SP TRIP	Single pole tripping will be used in this application.
SP 62TRP TMR	1.0	Set to longer than the maximum single-pole dead time (open pole time between trip and reclose).
SP TRIP TMR	1.0	Set to longer than the maximum single-pole dead time. Set to longer than the maximum single pole dead time
SP RECL INIT	SINGLE POLE	Set to reclose on single pole trips and not reclose on 3 pole trips.
SPT BKR2 OUT	ENABLE	Three extra single pole trip outputs are required for this application.

Breaker Failure

Setting	Value	Comments and Calculations
BF Protection	ENABLE	BF Protection cannot be applied on breaker-and-a-half or ring bus applications.
BF SHORT TIMER	0.1	Multi-phase faults may need higher speed breaker failure clearing. This permits a shorter BF Time for multi-phase faults. 6 cycles is adequate time for 2 and 3 cycle breakers.
BF LONG TIMER	0.2	This permits a longer BF Time for phase-to-ground faults. 12 cycles is more secure time for 2 and 3 cycle breakers.
BF CONTROL TMR	0.300	Set 0.1 greater than long timer.

I/O Mapping

Inputs

The following inputs are required or need to be considered.

Mapped Signal	Input #	Comments
85CO	1	This signal must be mapped and the rated input dc voltage applied to enable pilot operation.
CHANNEL RECEIVE 1	2	This must be mapped for all 2 and 3 terminal pilot applications for the first [or only] receiver input.
CHANNEL RECEIVE 2	3	This must be mapped for 3 terminal pilot applications that require a second receiver input. (All except blocking)
CHANNEL BLOCK 1	4	This must be mapped for all 2 and 3 terminal pilot UNBLOCK applications where trip and guard signals are used for the first [or only] receiver input.
CHANNEL BLOCK 2	5	This must be mapped for all 3 terminal pilot UNBLOCK applications where trip and guard signals are used for the second receiver input.
BREAKER 1 CLOSED 52 A	6	Breaker position will be determined with the breaker 52a auxiliary contact. The 52a must be used if the trip circuit monitoring function is to be used. Map both BREAKER 1 and BREAKER 2 signals to the same input for single bus applications. If there are two breakers feeding the line [*ring or 1 ½ breaker busses] map to separate inputs. The BREAKER OPEN 52b signals could be used instead of 52a with
BREAKER 2 CLOSED 52 A	6 or [*7]	appropriate changes in the mapped signal.
TRIP CIRCUIT 1	8	Monitor (connect) the dc voltage across the tripping contact (REL 512 tripping contact or 94T relay contact) in the breaker trip coil circuit #1.
TRIP CIRCUIT 2	9	Monitor (connect) the dc voltage across the tripping contact (REL 512 tripping contact or 94T relay contact) in the breaker second trip coil circuit #2.
XDFR	10	Trigger a REL 512 DFR record from an external source.
	11	The remaining inputs may be used to monitor the status of other
	12	devices external to the REL 512.

Outputs

There are no outputs that must be mapped by setting or programmed with RELLOGIC for correct protection operation for most applications. Trip, pilot communication, relay in service alarm outputs are fixed. Additional mapped or programmed outputs may be required for special applications. The following outputs need to be considered

Mapped Signal	Output #	Comments
IN SERVICE	1	Fixed
HS LOP BLOCK SET	2	This signal is mapped to provide external alarm that the relay is in a loss of potential state.
TCM 52 ALARM 1	3	This signal is mapped to provide external alarm that there is a problem in the breaker trip circuit #1.
TCM 52 ALARM 2	4	This signal is mapped to provide external alarm that there is a problem in the second breaker trip circuit #2.
DC OFFSET ALARM	5	This signal is mapped to provide external alarm that there is a problem in the DC electronic reference of the relay
	6	The remaining outputs may be used for auxiliary programmable logic functions utilizing REL 512 functions and logic signals created in RELLOGIC. There are no REL 512 protection functions that require the use of RELLOGIC.
	7	
	8	
	9	
	10	
	11	
	12	
BREAKER FAIL INITIATE	13	This signal is mapped to provide external alarm that the relay initiated tripping
PILOT CHANNEL STOP	14	Fixed
PILOT CHANNEL START	15	Fixed
3P TRIP SEAL or SPT SEAL A	16	Fixed
3P TRIP SEAL or SPT SEAL B	17	Fixed
3P TRIP SEAL or SPT SEAL C	18	Fixed

Contributed by:
Sethuraman Ganesan
Elmo Price
Revision 1, 03/21/03

ABB, Inc.
7036 Snowdrift Road
Allentown, PA 18106
800-634-6005 Fax 610-395-1055
Email: powerful.ideas@us.abb.com
Web: www.abb.com/substationautomation