

# Motor protection and control REM615

The REM615 is a dedicated motor protection and control IED perfectly aligned for the protection, control, measurement and supervision of asynchronous motors in manufacturing and process industry. REM615 is a member of ABB's Relion® product family and a part of its 615 protection and control product series. The 615 series IEDs are characterized by their compactness and withdrawable design. Engineered from the ground up, the 615 series has been designed to unleash the full potential of the IEC 61850 standard for communication and interoperability between substation automation devices.

## Unique REM615 ANSI features

- Six setting groups
- Drawout design
- High-speed (< 1 ms) outputs
- Normally-closed output for motor contactors
- Dedicated machine-run-time timers
- Machine differential
- Up to six RTD inputs available
- Loss-of-load supervision
- Arc flash detection (AFD)
- Thermal overload protection of motor
- Ring-lug terminals for all inputs and outputs
- Large, easy to read LCD screen
- Environmentally friendly design with RoHS compliance

## Application

The REM615 constitutes main protection for asynchronous motors and their drives in manufacturing and process industry. Typically, the motor IED is used with circuit breaker or contactor controlled HV motors, and contactor controlled medium sized and large LV motors in a variety of drives, such as pumps and conveyors, crushers and choppers, mixers and agitators, fans, and aerators. Flexible coding allows for choosing current-only or current-and-voltage configurations to best fit your motor application needs.

## Protection and control

REM615 offers all the functionality needed to manage motor starts and normal drive operations, including protection and fault clearance in abnormal situations. The main features of the motor IED include thermal overload protection, motor start-up



time supervision, locked rotor protection, and protection against too frequent motor starts. Furthermore, the IED offers negative phase sequence current unbalance protection, motor running stall protection, loss-of-load supervision, phase-reversal protection, and a provision to perform a forced emergency start.

REM615 incorporates non-directional and directional ground-fault protection, back-up overcurrent protection, three phase undervoltage, negative phase sequence overvoltage, and positive sequence undervoltage protection. A fast three-channel arc-fault protection system for arc flash supervision of the switchgear compartments is offered. To protect from unauthorized access and to maintain the integrity of information, the IED has been provided with a four-level, role-based, user authentication system. The access control system applies to the front panel HMI, the web browser based HMI and the PCM600 Protection and Control IED Manager.

## Standardized communication

REM615 genuinely supports the new IEC 61850 standard for inter-device communication in substations. It also supports the industry standard Modbus® protocol, and the well-established DNP3 and IEC 60870-5-103 protocols. For accurate time stamping, REM615 supports synchronization over Ethernet using SNTP or over a separate bus using IRIG-B.

### Pre-emptive condition monitoring

For continuous knowledge of the operational availability of the REM615 features, a comprehensive set of monitoring functions to supervise the relay health, the trip circuit, and the circuit breaker health is included. The breaker monitoring can include checking the wear and tear of the circuit breaker, the spring charging time of the breaker operating mechanism, and the gas pressure of the breaker chambers. The relay also monitors the breaker travel time and the number of circuit breaker operations to provide basic information for scheduling breaker maintenance.

### Bus protection via GOOSE

The IEC 61850 implementation in REM615 also includes fast peer-to-peer communication over the substation bus. Use GOOSE communication between the the REM615, RET615, and REF615 IEDs of the incoming and outgoing feeders of a substation cooperate to form a stable, reliable and high-speed busbar protection system. The cost-effective GOOSE-based busbar protection is obtained just by configuring the IEDs and the operational availability of the protection is assured by continuous supervision of the protection IEDs and their GOOSE messaging over the station bus. No separate hard-wiring is needed for the horizontal communication between the switchgear cubicles.

REM615 V4.0 ANSI Functional Applications A, C - F

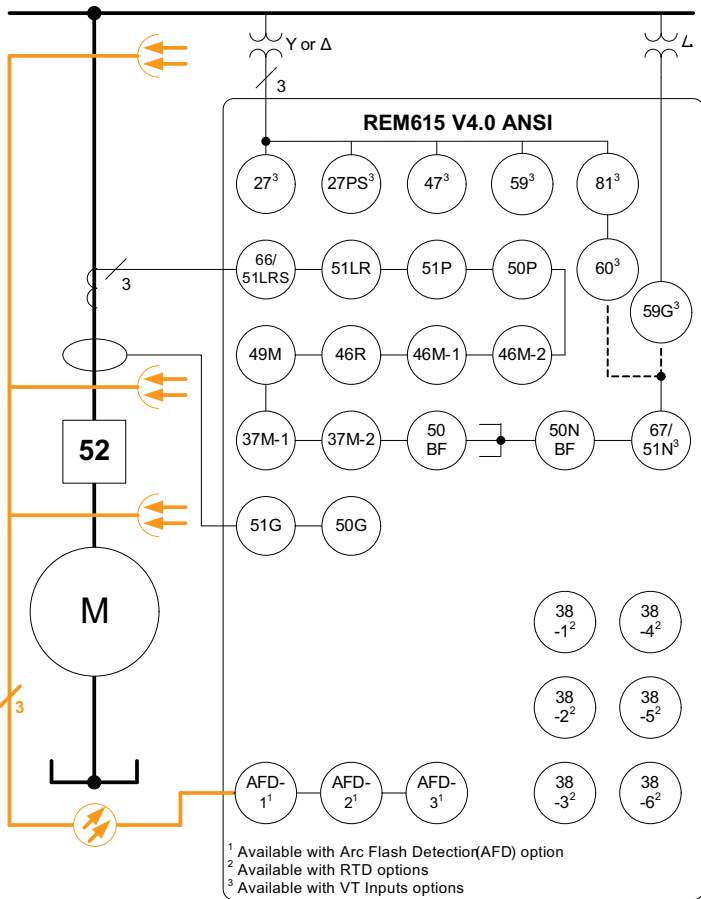

REM615 V4.0 ANSI Functional Application B

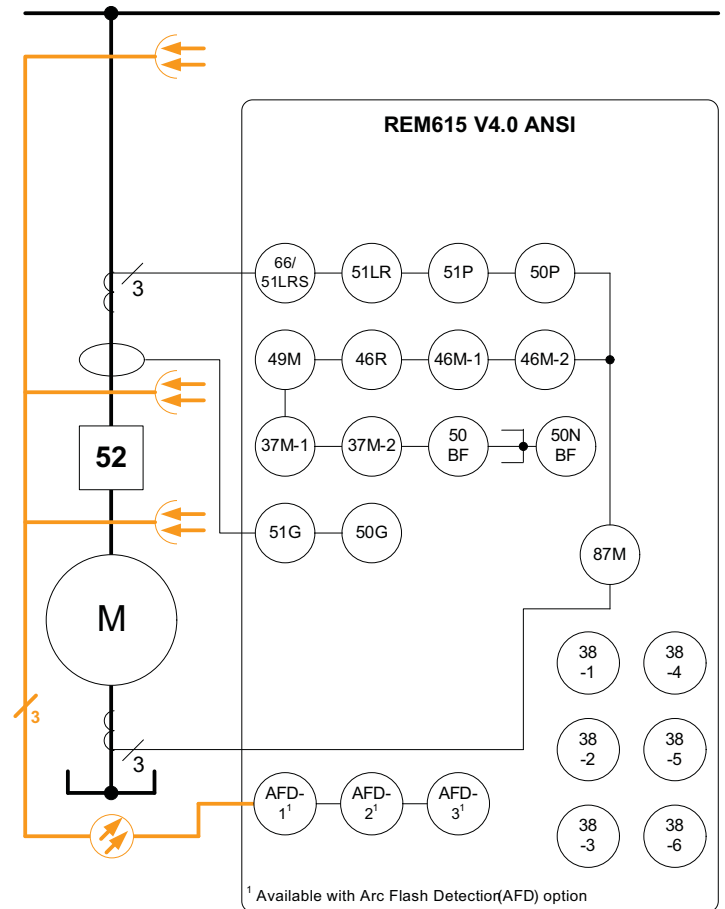

Functions and Features		Functional Application					
		A	B	C	D	E	F
<b>Included = •, Optional = ○</b>							
<b>Protection</b>	<b>ANSI Function Name</b>						
Phase overcurrents	51P, 50P	•	•	•	•	•	•
Ground overcurrents	51G, 50G	•	•	•	•	•	•
Directional neutral overcurrent	67N			•	•	•	•
Machine differential	87M		•				
Thermal overload	49M	•	•	•	•	•	•
Loss-of-load	37M-1, 37M-2	•	•	•	•	•	•
Phase reversal	46R	•	•	•	•	•	•
Locked rotor / start	66/51LRS	•	•	•	•	•	•
Locked rotor / jam	51LR	•	•	•	•	•	•
Negative sequence overcurrents	46M-1, 46M-2	•	•	•	•	•	•
Phase undervoltage	27			•	•	•	•
Positive sequence undervoltage	27PS			•	•	•	•
Phase sequence overvoltage	47			•	•	•	•
Ground overvoltage	59G			•	•		
Frequency	81			•	•	•	•
Resistive thermal devices (RTD)	38		•		•		•
Circuit breaker failure	50BF, 50NBF	•	•	•	•	•	•
Electrically latched/self-resetting trip digital outputs	86/94-1, 86/94-2	•	•	•	•	•	•
Arc flash detection via three lens sensors	AFD-1, AFD-2, AFD-3	○	○	○	○	○	○
<b>Control</b>							
Circuit breaker control	52	•	•	•	•	•	•
Emergency restart	62EST	•	•	•	•	•	•
<b>Monitoring and Supervision</b>							
Trip circuit monitoring	TCM	•	•	•	•	•	•
Breaker condition monitoring	52CM	•	•	•	•	•	•
Fuse failure	60			•	•	•	•
Open CT secondary monitoring	CCM	•	•	•	•	•	•
Machine run timers	OPTM-1, OPTM-2	•	•	•	•	•	•
<b>Measurement</b>							
Three-phase currents	IA, IB, IC	•	•	•	•	•	•
Sequence currents	I1, I2, I0	•	•	•	•	•	•
Ground current	IG	•	•	•	•	•	•
Demand phase currents		•	•	•	•	•	•
Maximum and minimum demand values		•	•	•	•	•	•
Three-phase voltages	VA, VB, VC			•	•	•	•
Sequence voltages	V1, V2, V0			•	•	•	•
Ground voltage	VG			•	•		
Power and energy (1-phase, 3-phases) and power factor	P, E and PF			•	•	•	•
<b>Automation &amp; Communications</b>							
100Base-TX Ethernet (RJ45)		○	○	○	○	○	○
100Base-FX Ethernet(LC)		○	○	○	○	○	○
100Base-TX Ethernet(RJ45) + RS-485(1x4-wire or 2x2-wire) + IRIG-B		○	○	○	○	○	○
100Base-FX Ethernet(LC) + RS-485(1x4-wire or 2x2-wire) + IRIG-B		○	○	○	○	○	○
100Base-TX and -FX Ethernet (1 * LC, 2 * RJ45) + serial glass fiber (ST)		○	○	○	○	○	○
100Base-TX Ethernet (3 * RJ45) + serial glass fiber (ST)		○	○	○	○	○	○
Ethernet 100Base-TX (RJ45) + configurable RS232/RS485 + [RS485 or serial glass fiber (ST) + IRIG-B] <sup>1</sup>		○	○	○	○	○	○
<b>Records</b>							
Sequence of events recorder	SER	•	•	•	•	•	•
Fault recorder	FLR	•	•	•	•	•	•
Digital fault (waveform) recorder	DFR	•	•	•	•	•	•

<sup>1</sup> Not available with Arc Flash Detection (AFD) option

### Analog inputs

- Three phase currents: 5/1 A programmable
- Ground current: 5/1 A programmable  
Rated frequency: 60/50 Hz programmable
- Three-phase and ground voltages: programmable nominal secondary voltage (available as option)
- RTD inputs (available as an option)

### Binary inputs and outputs

- Eight, twelve with VT inputs, binary inputs standard
- Two NO outputs with trip circuit monitoring
- Three NO outputs
- One Form C output
- One Form C self-check alarm output
- Additional binary inputs and outputs available as options

### Communication

- IEC 61850-8-1 with GOOSE messaging
- DNP3.0 Level 2+ over TCP/IP
- Modbus over TCP/IP
- Time synchronization via SNTP (primary and backup servers)
- Optional serial RS-485 port programmable for DNP3.0 Level 2+ or Modbus RTU
- Optional IRIG-B time synchronization

### Control voltage

- Option 1: 48 ... 250 V dc, 100 ... 240 V ac
- Option 2: 24 ... 60 V dc

### Product dimensions and weights

- Frame: 6.97" (177 mm) W x 6.97" (177 mm) H
- Case: 6.57" (165 mm) W x 6.30" (160 mm) H x 6.10" (155 mm)
- Weight: Relay - 7.72 lbs. (3.5 kg); Draw-out unit - 3.97 lbs. (1.8 kg)

### Tools

- PCM600 V2.3 for setting, configuration and data retrieval
- COM600 Station Automation series products V3.4
- Web browser based user interface (IE 7.0 or later)

### Certificates

- UL Listed product, File E103204

### ABB Inc.

#### Distribution Automation

4300 Coral Ridge Drive  
Coral Springs, Florida 33065  
Phone: +1 954 752 6700  
Fax: +1 954 345 5329

[www.abb.com/substationautomation](http://www.abb.com/substationautomation)

All sales are subject to ABB Inc.  
General Terms and Conditions of Sale.

While every effort has been made to assure accuracy, the information in this document is subject to change without notice.

© Copyright 2009, 2011 ABB Inc. All rights reserved.