



Station Automation COM600 3.5 IEC 61850 Proxy Server User's Manual

Contents:

1. About this manual	5
1.1. Copyrights	5
1.2. Trademarks	5
1.3. General	5
1.4. Document conventions	6
1.5. Use of symbols	7
1.6. Terminology	7
1.7. Abbreviations	9
1.8. Related documents	10
1.9. Document revisions	10
2. Introduction	11
2.1. Functional overview	11
2.2. IEC 61850 Proxy Server features	12
3. Configuration	13
3.1. About this section	13
3.2. Overview of configuration	13
3.3. Building object tree	14
3.3.1. General about building object tree	14
3.3.2. Adding IEC 61850 Proxy Server OPC Client object	15
3.3.3. Configuring IEC 61850 Proxy Server with Proxy Configuration Tool	15
3.4. IEC 61850 data publishing	16
3.4.1. About data sets	16
3.4.2. Configuring data sets	16
3.4.2.1. Dataset Editor	16
3.4.3. Data reporting	18
3.4.3.1. About data reporting	18
3.4.3.2. Report control block	18
3.4.4. Configuring reporting	22
3.4.5. GOOSE messaging	23
3.4.6. Configuring GOOSE publishing	25
3.5. Configuring objects	27
3.5.1. General about configuring objects	27
3.5.2. Configuring IEC 61850 Proxy Server OPC Client	28
3.5.3. Configuring IEC 61850 Proxy Subnetwork	28
3.5.4. Configuring IEC 61850 Proxy IED	29
3.5.5. Configuring IEC 61850 Proxy Device properties	30
4. Operation	31
4.1. About this section	31
4.2. Activating COM600 with new configurations	31

4.3.	Diagnostics	31
4.3.1.	IEC 61850 Proxy Server OPC Client	31
4.3.1.1.	Online diagnostics	31
4.3.1.2.	Diagnostic AE client	32
4.3.2.	IEC 61850 Proxy IED	33
4.3.3.	Online diagnostics	33
5.	Technical reference	35
5.1.	ASCI conformance statement	35
5.1.1.	ACSI conformance statement	35
5.1.2.	ACSI basic conformance statement	35
5.1.3.	ACSI models conformance statement	36
5.1.4.	ACSI service conformance statement	37
5.2.	SCL conformance	41
5.2.1.	SCL conformance statement	41
5.3.	PICS - protocol conformance statement	41
5.3.1.	Profile conformance	41
5.3.2.	MMS Conformance	42
Index	45

1. About this manual

1.1. Copyrights

The information in this document is subject to change without notice and should not be construed as a commitment by ABB Oy. ABB Oy assumes no responsibility for any errors that may appear in this document.

In no event shall ABB Oy be liable for direct, indirect, special, incidental, or consequential damages of any nature or kind arising from the use of this document, nor shall ABB Oy be liable for incidental or consequential damages arising from use of any software or hardware described in this document.

This document and parts thereof must not be reproduced or copied without written permission from ABB Oy, and the contents thereof must not be imparted to a third party nor used for any unauthorized purpose.

The software or hardware described in this document is furnished under a license and may be used, copied, or disclosed only in accordance with the terms of such license.

© Copyright 2011 ABB. All rights reserved.

1.2. Trademarks

ABB is a registered trademark of ABB Group. All other brand or product names mentioned in this document may be trademarks or registered trademarks of their respective holders.

1.3. General

This manual provides thorough information on the IEC 61850 Proxy Server and the central concepts related to it. You find instructions on taking it into use. The basic operation procedures are also discussed.

Information in this user's manual is intended for application engineers who configure the IEC 61850 Proxy Server OPC Client to establish communication to an OPC server.

As a prerequisite, you should understand IEC 61850 protocol and the basic procedures in Station Automation Builder 600 (later referred to as SAB600).

This user's manual is divided into following sections:

Introduction

This section gives an overview of the IEC 61850 Proxy Server and its features.

Configuration

In this section you find an overview of the configuration tasks and instructions on how to create and configure IEC 61850 Proxy Server OPC Client related objects.

Operation

This section covers the basic operation procedures you can carry out when transferring or activating Station Automation COM600 (later referred to as COM600) with new configurations.

You are also given instructions on how to monitor and control the IEC 61850 Proxy Server OPC Client.

Technical reference

This section contains a list of status codes and attributes.

1.4. Document conventions

The following conventions are used for the presentation of material:

- The words in names of screen elements (for example, the title in the title bar of a window, the label for a field of a dialog box) are initially capitalized.
- Capital letters are used for the name of a keyboard key if it is labeled on the keyboard. For example, press the ENTER key.
- Lowercase letters are used for the name of a keyboard key that is not labeled on the keyboard. For example, the space bar, comma key, and so on.
- Press CTRL+C indicates that you must hold down the CTRL key while pressing the C key (to copy a selected object in this case).
- Press ESC E C indicates that you press and release each key in sequence (to copy a selected object in this case).
- The names of push and toggle buttons are boldfaced. For example, click **OK**.
- The names of menus and menu items are boldfaced. For example, the **File** menu.
 - The following convention is used for menu operations: **MenuName > MenuItem > CascadedMenuItem**. For example: select **File > New > Type**.
 - The **Start** menu name always refers to the **Start** menu on the Windows taskbar.
- System prompts/messages and user responses/input are shown in the Courier font. For example, if you enter a value out of range, the following message is displayed:

```
Entered value is not valid. The value must be 0 - 30 .
```

- You can be asked to enter the string MIF349 in a field. The string is shown as follows in the procedure:

MIF349

- Variables are shown using lowercase letters:

sequence name

1.5. Use of symbols

This publication includes warning, caution, and information icons that point out safety-related conditions or other important information. It also includes tip icons to point out useful information to the reader. The corresponding icons should be interpreted as follows.



The electrical warning icon indicates the presence of a hazard which could result in electrical shock.



The warning icon indicates the presence of a hazard which could result in personal injury.



The caution icon indicates important information or warning related to the concept discussed in the text. It may indicate the presence of a hazard which could result in corruption of software or damage to equipment or property.



The information icon alerts the reader to relevant facts and conditions.



The tip icon indicates advice on, for example, how to design your project or how to use a certain function.

1.6. Terminology

The following is a list of terms associated with COM600 that you should be familiar with. The list contains terms that are unique to ABB or have a usage or definition that is different from standard industry usage.

Term	Description
Alarm	An abnormal state of a condition.

Term	Description
Alarms and Events; AE	An OPC service for providing information about alarms and events to OPC clients.
Data Access; DA	An OPC service for providing information about process data to OPC clients.
Data Object; DO	Part of a logical node object representing specific information, for example, status, or measurement. From an object-oriented point of view, a data object is an instance of a class data object. DOs are normally used as transaction objects; that is, they are data structures.
Data Set	The data set is the content basis for reporting and logging. The data set contains references to the data and data attribute values.
Device	A physical device that behaves as its own communication node in the network, for example, protection relay.
Event	Change of process data or an OPC internal value. Normally, an event consists of value, quality, and timestamp.
Intelligent Electronic Device	A physical IEC 61850 device that behaves as its own communication node in the IEC 61850 protocol.
Logical Device; LD	Representation of a group of functions. Each function is defined as a logical node. A physical device consists of one or several LDs.
Logical Node; LN	The smallest part of a function that exchanges data. An LN is an object defined by its data and methods.
LON	A communication protocol developed by Echelon.
LON Application Guideline for substation automation; LAG	A proprietary method of ABB on top of the standard LON protocol.
OPC	Series of standards specifications aiming at open connectivity in industrial automation and the enterprise systems that support industry.
OPC item	Representation of a connection to the data source within the OPC server. An OPC item is identified by a string <object path>:<property name>. Associated with each OPC item are Value, Quality, and Time Stamp.
Property	Named data item.
Report Control Block	The report control block controls the reporting processes for event data as they occur. The reporting process continues as long as the communication is available.
SPA	ABB proprietary communication protocol used in substation automation.
SPA device	Protection and/or Control Product supporting the SPA protocol version 2.5 or earlier.
Substation Configuration Language; SCL	XML-based description language for configurations of electrical substation IEDs. Defined in IEC 61850 standard.

1.7. Abbreviations

The following is a list of abbreviations associated with COM600 that you should be familiar with. See also 1.6, Terminology.

Abbreviation	Description
AE	Alarms and Events
ASDU	Application Service Data Unit
BRCB	Buffered Report Control Block
DA	Data Access
DMCD	Data Message Code Definition
DO	Data Object
GW	Gateway, component connecting two communication networks together
HMI	Human Machine Interface
IEC	International Electrotechnical Commission
IED	Intelligent Electronic Device
LAG	LON Application Guideline for substation automation
LAN	Local Area Network
LD	Logical Device
LN	Logical Node
NCC	Network Control Center
NV	Network Variable
OLE	Object Linking and Embedding
OPC	OLE for Process Control
P&C	Protection & Control
RTS	Request To Send
SA	Substation Automation
SAB600	Station Automation Builder 600
SCL	Substation Configuration Language
SLD	Single Line Diagram
SNMP	Simple Network Management Protocol
SNTP	Simple Network Time Protocol
SOAP	Simple Object Access Protocol
RCB	Report Control Block
URCB	Unbuffered Report Control Block
XML	eXtended Markup Language

1.8. Related documents

Name of the manual	MRS number
COM600 User's manual	1MRS756125

1.9. Document revisions

Document version/date	Product revision	History
A/30.6.2011	3.5	Document created

2. Introduction

2.1. Functional overview

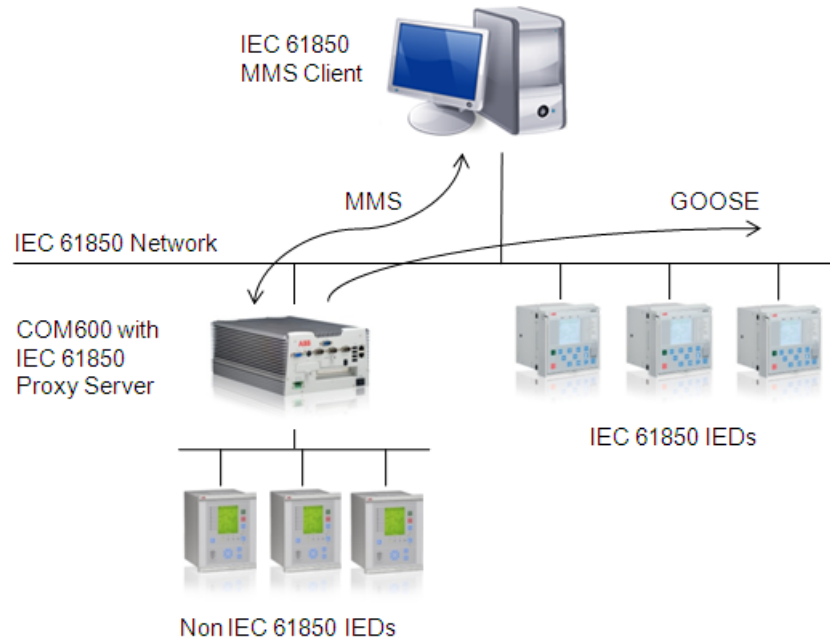

IEC61850_Proxy_Server_Functional_Overview.PNG

Figure 2.1-1 Functional overview of IEC 61850 Proxy Server

IEC 61850 Proxy Server enables IEC 61850-8-1 MMS clients to access data and services of COM600. It also features a GOOSE send functionality for publishing data. With these features, it is possible to connect non-IEC61850 IEDs to the IEC 61850 network via COM600. Also calculated data from COM600 (e.g. from logic processor) can be published to IEC61850 network using the IEC 61850 Proxy Server.

IEC61850 Proxy Server is configured using the Proxy Configuration tool in SAB600. The Proxy Configuration tool shows a list of IEDs and their logical devices that are configured to COM600. You can select which of them will be added to the IEC61850 Proxy Server configuration. As the COM600 native data model is according to the IEC 61850 standard, complicated cross-reference configuration is not required. You can later adjust the data set and reporting configuration. The IEC 61850 Proxy Server configuration is stored into an SCL file, which is loaded to the COM600. The configuration can also be exported to an SCL SCD file, which can be used for the IEC 61850 client configuration.

When the IEC 61850 Proxy Server is started, it first reads and parses the SCL configuration. It creates the IEC 61850 data model according to the SCL and establishes connections to the related COM600 OPC servers. It initiates a refresh for the OPC servers to update all configured data. After the data is received, the IEC 61850 Proxy Server has

up-to-date data from the underlying process and the IEC 61850 server is started. The IEC 61850 Proxy Server starts normal operation. During normal operation the actions for the IEC 61850 Proxy Server are initiated by IEC 61850 service request from an IEC 61850 client or by data updates from the connected OPC servers.

2.2. IEC 61850 Proxy Server features

The IEC 61850 Proxy Server supports the following features:

- OPC Data Access v1.0/2.0 (client for process data, server for diagnostics)
- OPC Alarms and Events specifications v1.10 (server for diagnostics)
- IEC 61850 server
 - IEC 61850 data modeling
 - IEC 61850 buffered and unbuffered reporting services
 - IEC 61850 control services
 - IEC 61850 GOOSE send service
- One instance of IEC 61850 Proxy Server can be configured per COM600

3. Configuration

3.1. About this section

This section guides you in the configuration tasks required before you can start using the IEC 61850 Proxy Server. For information on the IEC 61850 data modeling, refer to COM600 User's Manual.

1. Select **File > Open/Manage Project...**
2. In the Open/Manage Project dialog, select the required location for the project:
 - Projects on my computer
 - Projects on network
3. Select **New Project** on the left.
 - Enter a Project Name. The Description is optional.
4. Click **Create**.
5. Click **Open Project**.

3.2. Overview of configuration

Before you can start using the IEC 61850 Proxy Server, you need to build and configure an object tree in SAB600 to define the communication structure. Start the configuration by first configuring an OPC Server, for example, LON OPC Server. Then continue to configure the IEC 61850 Proxy Server. For information on configuring the OPC Server, see the related configuration manual.

Figure 3.2-1 shows an example view of SAB600 including an object tree in the communication structure on the left and Object Properties window displaying the object properties on the right.



When configuring OPC servers the following characters cannot be used in object names: \ ` ' ' #. Also avoid using a space in object names.

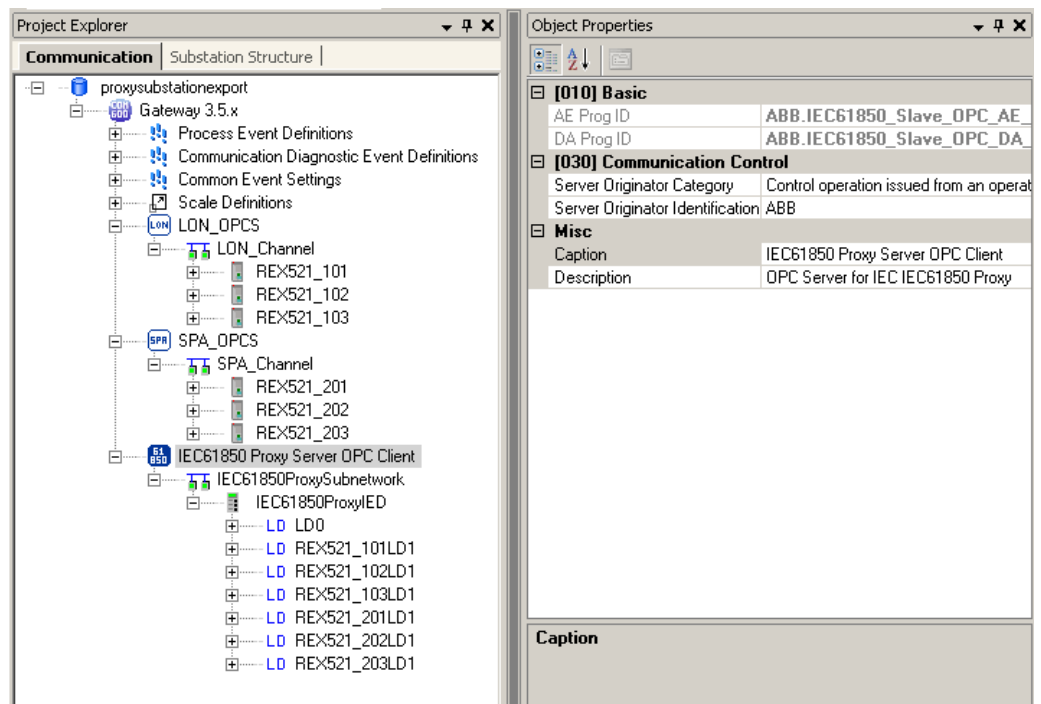

overview_PROXY.png

Figure 3.2-1 Example view of SAB600 communication structure

The configuration work can be divided into two separate tasks:

1. building an object tree, and
2. configuring object properties.

First, you need to build an object tree. This is done by adding objects to the object tree, see 3.3.1, General about building object tree.

Figure 3.2-1 shows an example of how the object tree may look like after it has been built. In the example tree you can see the IEC 61850 Proxy Server OPC Client object and its child objects, such as subnetwork, devices, and data objects. Indentation is used to indicate the parent-child relationship between the objects.

After you have added the necessary objects to the object tree in the communication structure, you need to configure them, see 3.5.1, General about configuring objects.

3.3. Building object tree

3.3.1. General about building object tree

The object tree is built in the Communication structure of SAB600, see Figure 3.2-1. It is built by adding objects in a logical order starting from the OPC Server object.

Before the IEC 61850 Proxy Server can be taken into use, you need to configure an OPC server for the process communication. For more information on creating an OPC server, refer to COM600 User's Manual.

You have two ways to add objects to the object tree in the Communication structure:

- You can right-click the object to which you want to add a child object.
- You can copy the object.

First add the IEC 61850 Proxy Server OPC Client. The following objects are created by the Proxy Configuration Tool, and should not be added manually:

- IEC 61850 Proxy Subnetwork
- IEC 61850 Proxy IED
- Logical Devices
- Data objects

3.3.2. Adding IEC 61850 Proxy Server OPC Client object

To add the IEC 61850 Proxy Server OPC Client object:

1. Add the IEC 61850 Proxy Server OPC Client object in the Communication structure by selecting the Gateway object.
2. Right-click the Gateway object and select the server object, for example **New > IEC61850 > IEC61850 Proxy Server OPC Client**.

3.3.3. Configuring IEC 61850 Proxy Server with Proxy Configuration Tool



Before configuring Proxy IEC 61850 Proxy Server, an OPC server handling the IED communication needs to be configured to the communication structure.

To configure IEC 61850 Proxy Server with the Proxy Configuration Tool:

1. Right-click the IEC 61850 Proxy Server OPC Client object and select **Proxy Config Tool**.
2. Select the check-boxes in the first column to add LDs to the IEC61850 Proxy Server OPC Client configuration.
3. Click **Apply** to create the configuration with the selected IEDs to the communication structure.

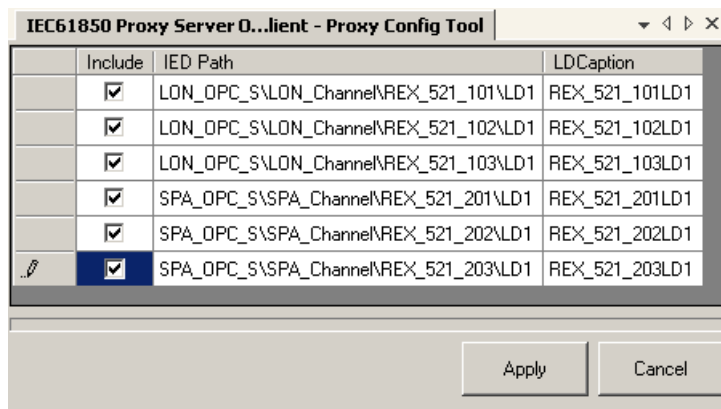

Proxy_config_tool.png

Figure 3.3.3-1 Proxy Configuration Tool

The Proxy Configuration Tool includes the following columns:

- **Include:** specifies if the LD is part of the Proxy configuration
- **IED Path:** the OPC path of the selected LD
- **LD Caption:** specifies the name of the referenced LD in the Proxy configuration

3.4. IEC 61850 data publishing

3.4.1. About data sets

A data set is an ordered group of data objects and data attributes organized as a single collection for the convenience of the client. Data sets are used to define the values of data to be transmitted in case a value of a data set member changes. A data set is used for reporting and GOOSE messaging.

3.4.2. Configuring data sets

3.4.2.1. Dataset Editor

A data set groups selected data so that a client can access it easily with a single read operation. A data set is also used for event reporting; data is linked to spontaneous event sending only via report control blocks (RCB) data set definition. The client reads other data separately. Data set definitions are located always under the logical device LD0 and logical node LLN0.

The data set can be modified with the Dataset Editor. Open the Dataset Editor by right-clicking the Dataset object and selecting **Dataset Editor**.

The Dataset object has a set of data attributes:

- **IdInst:** Instance of Logical Device to which the referenced data set belongs.

- **Prefix:** Freely configurable part of LN caption.
- **InInst:** Instance of the LN type.
- **InClass:** Logical node class.
- **doName:** Name of the data object from which the data set is formed.
- **daName:** Name of the data attribute from which the data set is formed.
Data attributes are collected to the data set in groups, and the functional constraint defines the data attributes.
- **fc:** functional constraint
Functional constraint divides data attributes, which have the same functional constraint, to groups under the same data object. For example, functional constraint ST (status information) groups stVal, q and t data attributes to the data set.

The caption in the object tree consists of Prefix, InClass and InInst values.

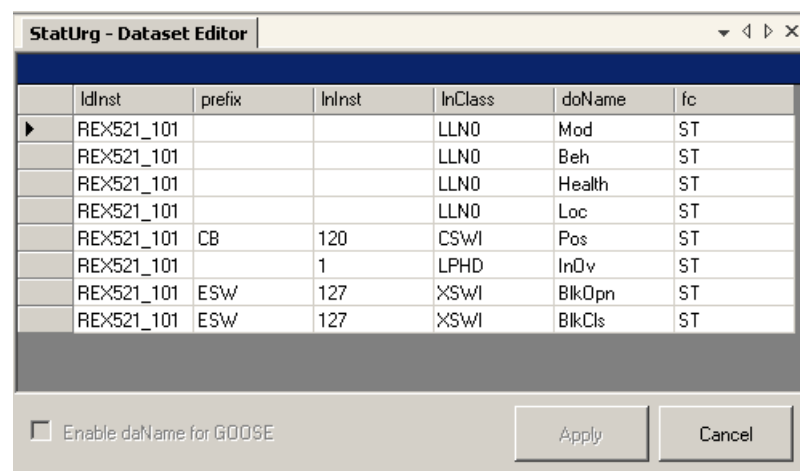

Dataset_editor.png

Figure 3.4.2.1-1 Dataset Editor

Creating data sets

If 61850 naming is used, the Proxy Configuration Tool automatically creates StatNrml, StatUrg and MeasFlt data sets and report control blocks for them. The creation is based on proxy_dataset_defaults.xml file, which is located in the [installation drive]:\PCM-DataBases\COM600\ProxyConfigTool folder.

The file has the following format:

```
<DataSet name="[name of dataset]">
  <LNClass name="[LNClass of ln]">
    <DO cdc = "[61850-Type of DO]" name = "[Caption of
DO]">
      ...
    </DO>
  </LNClass>
  ...
</DataSet>
```

The data set identifies the data set to be created. LNClass and DO are used to determine which LN/DOs should be added to the dataset. For example:

```
<DataSet name="StatNrml">
  <LNClass name="GGIO">
    <DO cdc="SPS" name="Alm"/>
  </LNClass>
  <LNClass name="PHAR">
    <DO cdc="ACD" name="Str"/>
  </LNClass>
```

The StatNrml data set contains all Alm named SPS typed DOs under GGIO LNClass and all str named ACD typed DOs under PHAR LNClass, and so on.

Additional signals can be added to each data set by dragging and dropping the DO object to the Dataset Editor tool and applying changes.

The data sets for GOOSE have to be created manually.

To create data sets for GOOSE:

1. Create a Dataset object to the tree under the LN0 object.
2. Right-click the Dataset object and select **Dataset Editor**.
3. If you are creating a GOOSE data set, select the **Enable daName for GOOSE** checkbox.
4. Drag and drop DO objects from the object tree to the Dataset Editor.
5. Click **Apply**.

3.4.3. Data reporting

3.4.3.1. About data reporting

Data changes are used as a trigger for reporting. This information is grouped using a data set. The data set is the content basis for reporting. Reporting uses information reports to transmit data. The data configured in a data set is transmitted in information reports. Reporting is controlled by report control blocks.

3.4.3.2. Report control block

Report control describes the conditions for generating information reports based on parameters set by configuration or by a client. Report Control Blocks control the procedures that are required for reporting values of data from logical nodes to one client.

There are buffered and unbuffered report control blocks:

- In a **Buffered Report Control Block (BRCB)** internal events issue immediate sending of reports, or buffer the events for transmission. This way the values of a

data object are not lost due to transport flow control constraints or loss of connection. BRCB provides sequence-of-events functionality.

- In an **Unbuffered Report Control Block (URCB)** internal events issue immediate sending of reports on a best efforts basis. If no association exists, or if the transport data flow is not fast enough to support it, events may be lost.

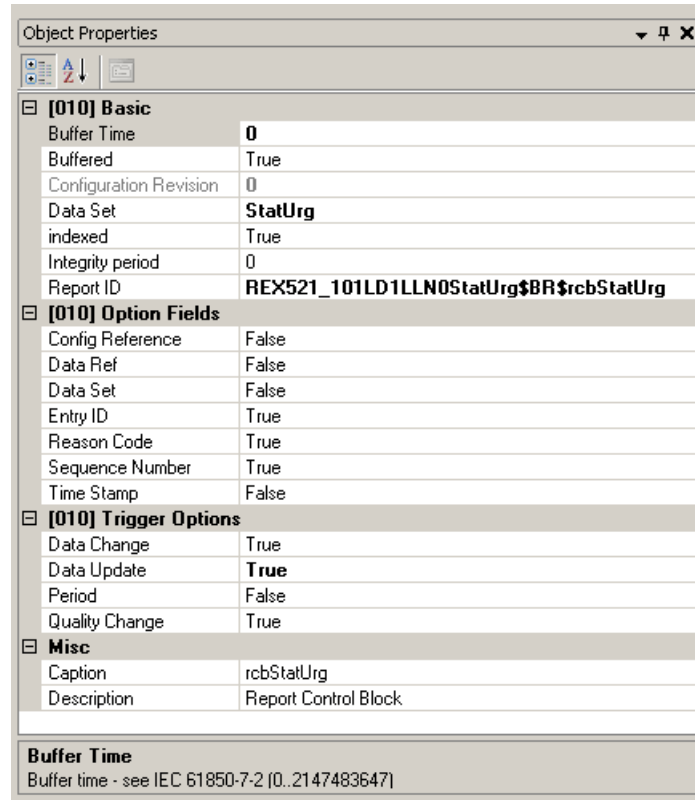

report_control_block_properties.png

Figure 3.4.3.2-1 Report control block properties

Table 3.4.3.2-1 Report Control Block object properties

Property/Parameter	Value or value range/Default	Description
Basic		
Buffer Time	Default: 0 milliseconds	With this value, RCB can be configured to wait for other events after the first change before sending the report. Value 0 means that a new change is immediately reported to the client. Configurable.
Buffered	True False Default: True	Controls if the RCB is buffered or unbuffered.

Property/Parameter	Value or value range/Default	Description
Configuration Revision	0...2147483647	Configuration revision of the data set referenced by this RCB. Every modification in the data set increases the Configuration Revision property by one.
Data Set		The name of the data set to be sent by the report control block.
Indexed	True False Default: True	Indicates if this RCB is configured with indexed naming convention.
Integrity period	0...214748647 Default: 0	Integrity period in milliseconds. If this attribute has a value > 0 ms, an integrity report with all data listed in the data set is sent periodically in this interval. By default, this feature is not enabled, because it generates an unnecessary load to the server and network. If this feature is used, the Trigger Option 'Period' in RCB needs to be enabled. Configurable.
Report ID		Used as identification in information reports to specify that the report is from this RCB. By default report control block MMS path name is used. Configurable.
Option Fields		Defines what information is sent with the information report. Configurable.
Config Reference	True False Default: False	Config Reference
Data Ref	True False Default: False	Data Ref
Data Set	True False Default: False	Data Set

Property/Parameter	Value or value range/Default	Description
Entry ID	True False Default: True	Entry ID
Reason Code	True False Default: True	Reason Code
Sequence Number	True False Default: True	Sequence Number
Time Stamp	True False Default: False	Time Stamp
Trigger Options		Defines the triggering conditions for creating reports.
Data change	True False Default: True	Specifies whether a report entry shall be generated due to a change of the value of the data attribute.
Data Update	True False Default: False	Specifies whether a report entry shall be generated due to freezing the value of an unfreezable attribute or updating the value of any other attribute. An updated value may have the same value as the old value.
Period	True False Default: False	Specifies whether a report entry shall be generated on the expiration of the integrity period.
Quality Change	True False Default: True	Specifies whether a report entry shall be generated due to a change of the value of the quality attribute.

3.4.4. Configuring reporting

 Reporting is preconfigured automatically. Data sets for necessary data are created and linked to configured report control blocks.

To configure reporting:

1. Create and configure a **Data Set** object.

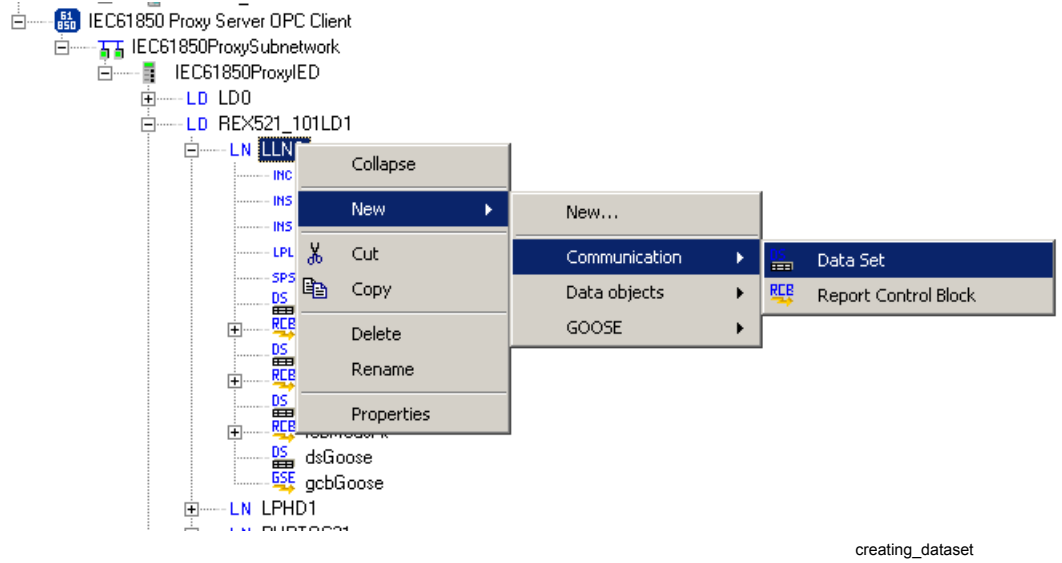

Figure 3.4.4-1 Creating a new data set

2. Create a **Report Control Block** object.

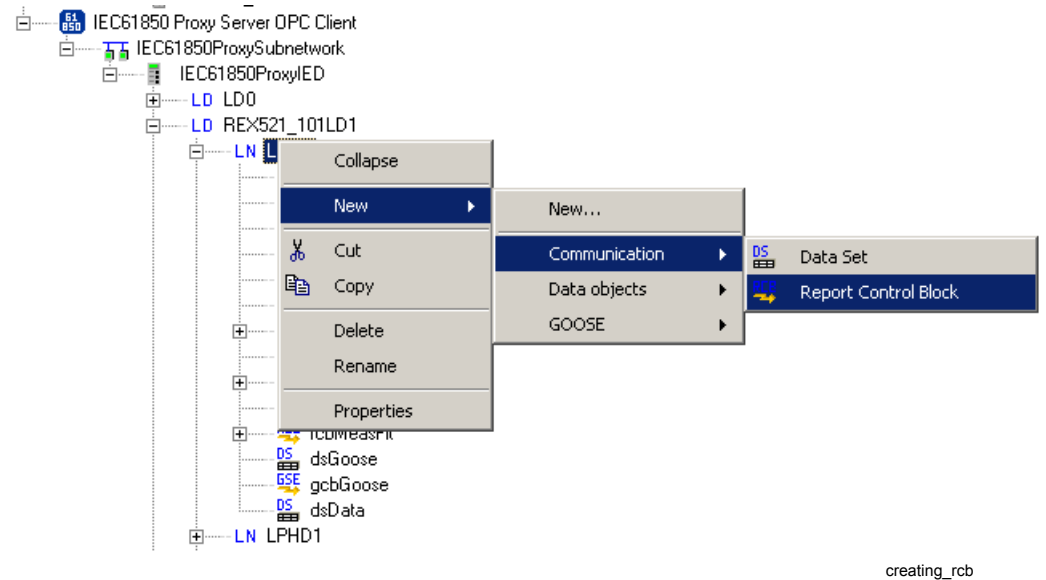
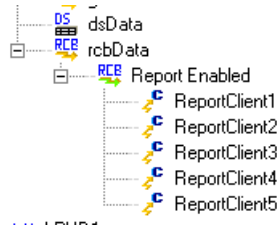

Figure 3.4.4-2 Creating a new report control block

3. Add a **Report Enabled** object. Add a **ReportClient** object for each IEC 61850 client. ReportClients create the same amount of instances of the RCB, each dedicated for one client.



ReportClient

Figure 3.4.4-3 Adding ReportClient objects

4. Configure the report control block.
5. Configure the data set of the report control block.

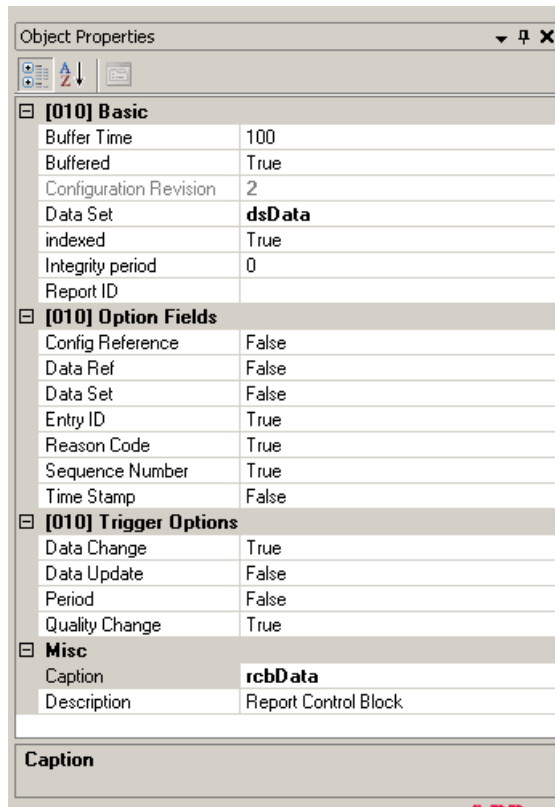

data_set_properties

Figure 3.4.4-4 Data set properties

3.4.5. GOOSE messaging

The generic object oriented substation event (GOOSE) is used in substation automation for fast horizontal communication between IEDs. It can be used to exchange, for example, interlocking and blocking information. The information is shared from one IED to one

or several IEDs using Ethernet multicast messages. A message is an image of a sent MMS data set that is defined in the CID configuration.

IEC61850 Proxy Server supports sending of GOOSE messages. The receiving of GOOSE messages is handled by the IEC 61850 OPC Server.

The GOOSE data is sent periodically in 802.1Q multicast frames over the local network. When data changes, the GOOSE frame is sent several times in a fast cycle to prevent data losses.

In GOOSE, the sent data is based on the data set and GOOSE Control Block (GoCB). The data set defines what type of data is sent in the GOOSE frame. GoCB links the GOOSE Control Block structure and its information to the data.

Table 3.4.5-1 lists the configurable GoCB object properties.

Table 3.4.5-1 GoCB object properties

Property/Parameter	Value or value range/Default	Description
Basic		
Configuration Revision	1	Configuration Revision identifies the version of GoCB.
Data Set	Data Set Default: None	Data set to be sent in GOOSE.
GSEType	Default: GOOSE	GSEType identifies the type of GSE Element in configuration file (read only parameter).
Goose Address		
APPID	0000 - 3FFF Default: 0000	Application ID for the GOOSE control block (hex value).
GoID	Default: (GOOSE control block path)	String identifier for the GOOSE control block.
Max Time	0...65535 Default: 10000	Supervision heartbeat cycle time (ms).
Min Time	0...65535 Default: 2	Maximal sending delay on a data change (ms).
Multicast Address	01-0C-CD-01-00-00 to 01-0C-CD-01-01-FF Default: 01-0C-CD-01-00-00	A multicast addressing scheme is used when sending GOOSE messages. A multicast address can be shared by several sending devices or it can be IED-specific.
VLAN-ID	000 - FFF Default: 000	VLAN-ID hex value.

Property/Parameter	Value or value range/Default	Description
VLAN-Priority	0...7 Default: 4	VLAN-Priority.

3.4.6. Configuring GOOSE publishing

To send GOOSE data, you must first define the sending data set used by the GOOSE control block and then create the control block.

1. Create a new **Data Set**. Rename it if you plan to use several different sets of data (see 3.4.2.1, Dataset Editor).

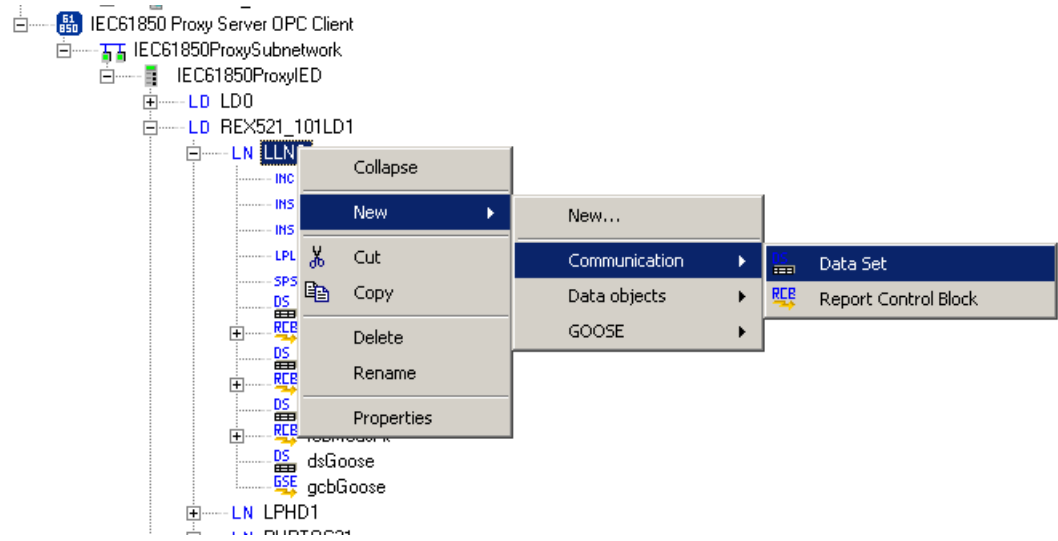

creating_dataset.png

Figure 3.4.6-1 Creating a new data set

2. Modify the data set to be sent with GOOSE.



Normally GOOSE data sets are configured to the attribute level and only the value and quality are used (e.g. **Pos.stVal** and **Pos.q**). Use the **Enable daName for GOOSE** option and manually remove the unnecessary attributes from the data set.

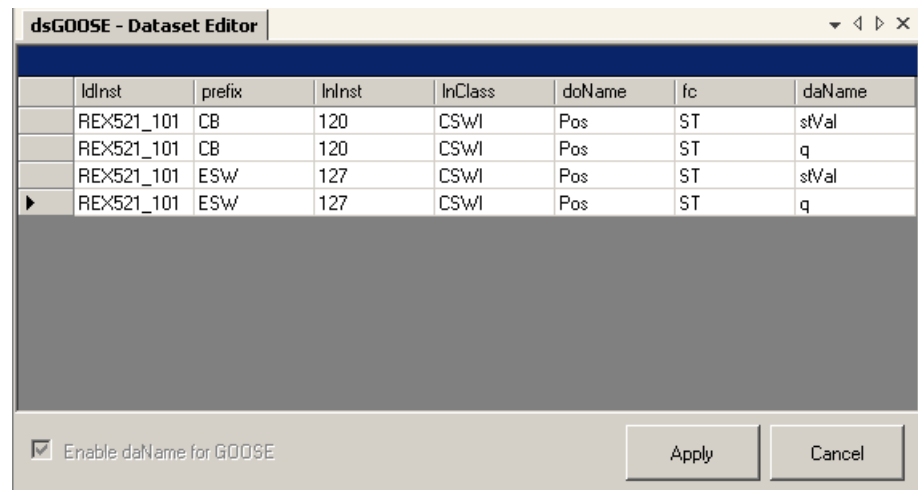

modifying_dataset.png

Figure 3.4.6-2 Modifying the data set to be sent with GOOSE

3. Create a new **GOOSE Control Block (GoCB)**.

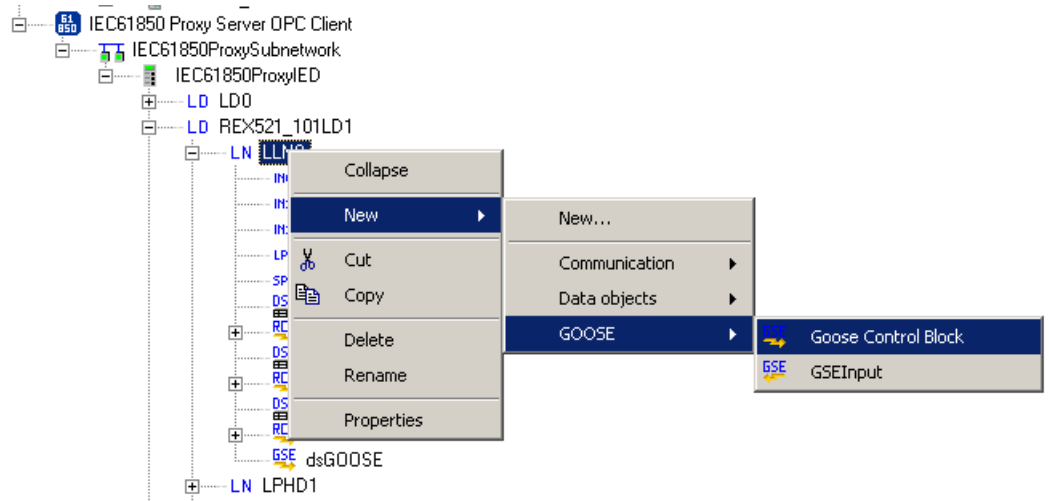

creating_gcb.png

Figure 3.4.6-3 Creating GOOSE Control Block

4. Configure the GOOSE control block, see Figure 3.4.6-4.
 - Select the created data set.
 - Define APPID (Application Identifier) which is unique within the system. It identifies the purpose of this particular dataset.
 - Define a multicast address to which the specific GOOSE data is sent. The receiving IED understands which frames with a specific multicast address are the interesting ones and starts to process them.

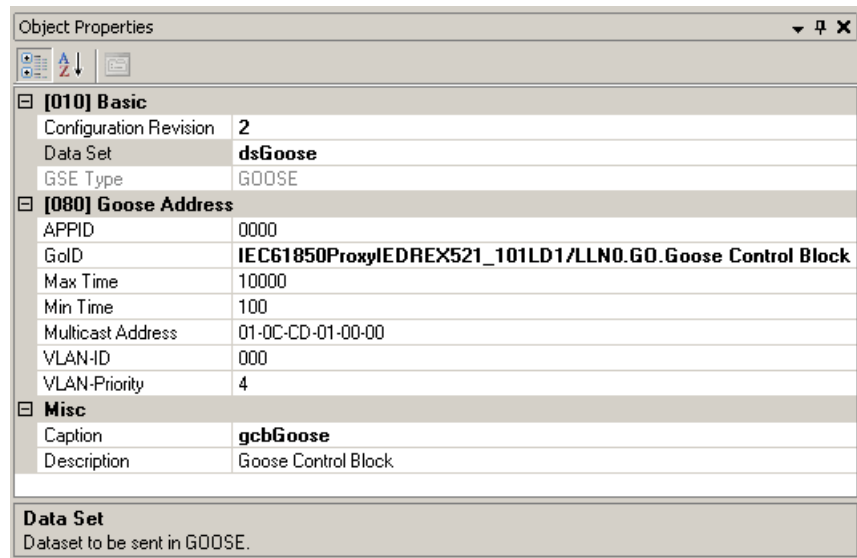

GOOSE_control_block_properties

Figure 3.4.6-4 GOOSE Control Block properties

3.5. Configuring objects

3.5.1. General about configuring objects

After the objects have been added, configure the object properties. Figure 3.5.1-1 shows an example of how to use SAB600 to configure the object properties for IEC 61850 Proxy Server OPC Client.

To configure an object:

1. Select an object in the object tree of the communication structure. The object properties appear in the Object Properties window. The properties and their values can be viewed as shown in Figure 3.5.1-1.

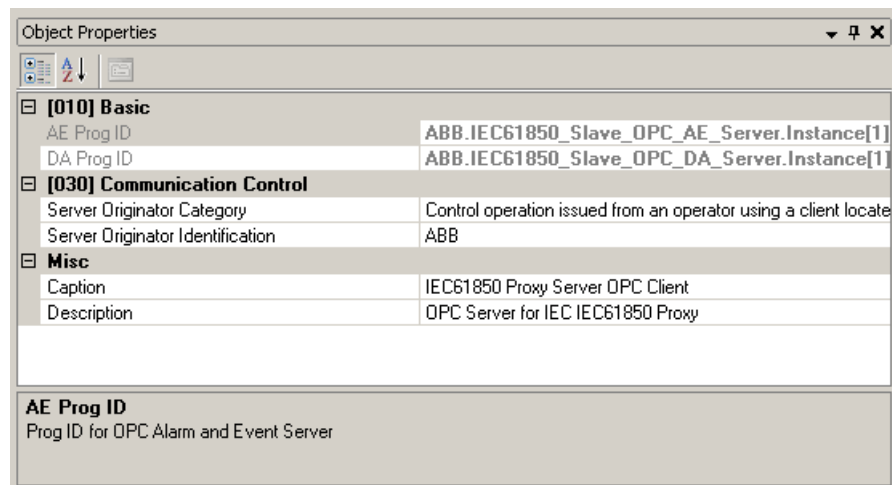

PROXY_object_properties.png

Figure 3.5.1-1 Example of object properties in the Objects Properties window

2. Select the property you want to configure. Depending on the property value type, configuring is always done either by:
 - selecting a predefined value from a drop-down menu, or
 - entering a text string or a numerical value in a text field.

The available properties for different objects are listed in the following subsections.

3.5.2. Configuring IEC 61850 Proxy Server OPC Client

IEC 61850 Proxy Server OPC Client does not have any configurable properties.

Table 3.5.2-1 IEC 61850 Proxy Server OPC Client properties

Property / Parameter	Value or Value range/ Default	Description
Basic		
AE Prog ID	ABB.IEC61850_Slave_OPC_AE_Server.Instance[1]	ProgID for OPC Alarm and Event Server. (not configurable)
DA Prog ID	ABB.IEC61850_Slave_OPC_DA.Instance[1]	ProgID for OPC Data Access Server. (not configurable)

3.5.3. Configuring IEC 61850 Proxy Subnetwork

Table 3.5.3-1 lists the configurable IEC 61850 Proxy Subnetwork object properties and the value ranges for them. The actual configuration using SAB600 is performed as described in 3.2, Overview of configuration.

Table 3.5.3-1 IEC 61850 Proxy Subnetwork properties

Property / Parameter	Value or Value range/ Default	Description
Communication Port		
Communication Port	ETH0 ETH1 Default: ETH0	LAN port used by the IEC 61850 protocol used for GOOSE sending. Values shown here are default values when no connection to COM600 has been made. When the first connection is made the communication port information is read from COM600 and the corresponding NIC value is written to NICInformation property.
IP Address	Default: 127.0.0.1	Communication channel IP address in dotted decimal format. (not configurable)
Communication Control		
TCP/IP Keepalive Timeout	1...3600 Default: 15 seconds	TCP/IP keepalive timeout in seconds.

3.5.4.**Configuring IEC 61850 Proxy IED**

Table 3.5.3-1 lists the configurable IEC 61850 Proxy IED object properties and the value ranges for them. The actual configuration using SAB600 is performed as described in 3.2, Overview of configuration.

Table 3.5.4-1 IEC 61850 Proxy IED properties

Property / Parameter	Value or Value range/ Default	Description
Addresses		
IP Address	Default: 127.0.0.1	Communication IP address in dotted decimal format. (not configurable)
OSI ACSE AE Qualifier	Default: 23	ACSE protocol level configuration parameter. AE Qualifier.
OSI ACSE AP Title Value	Default = 1,3,9999,23	ACSE protocol level configuration parameter. AP Title.
OSI Presentation Selector	Default = 00000001	ACSE protocol level configuration parameter. Presentation selector.
OSI Session Selector	Default = 0001	ACSE protocol level configuration parameter. Session selector.
OSI Transport Selector	Default = 0001	ACSE protocol level configuration parameter. Transport selector.

3.5.5. Configuring IEC 61850 Proxy Device properties

IEC 61850 Proxy Device does not have any configurable properties.

4. Operation

4.1. About this section

This section describes the basic operation procedures you can carry out after the IEC 61850 Proxy Server object properties have been configured.

After this, you can, for example, monitor and control the condition of connections in the Proxy Subnetwork. This is done by using the Online diagnostics function in SAB600.

4.2. Activating COM600 with new configurations

For information about activating COM600 with new configuration, see COM600 User's Manual.

4.3. Diagnostics

4.3.1. IEC 61850 Proxy Server OPC Client

4.3.1.1. Online diagnostics

To view version information on IEC 61850 Proxy Server Client or to monitor and control the state of the client, right-click the IEC 61850 Proxy Server OPC Client and select **Online diagnostics**.

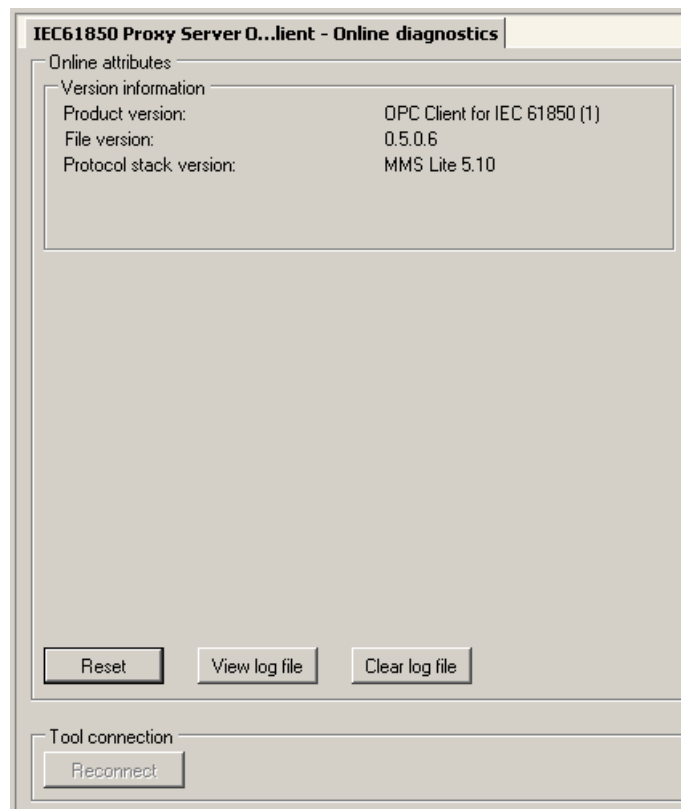

Proxy_online_diagnostics.png

Figure 4.3.1.1-1 IEC 61850 Proxy Server Online diagnostics

In Online diagnostics dialog box you can:

- reset the IEC 61850 Proxy Server OPC Client
- view the event log file
- clear the event log file

4.3.1.2. Diagnostic AE client

Diagnostic events can be monitored and controlled using the Diagnostic AE Client function, see Figure 4.3.1.2-1.

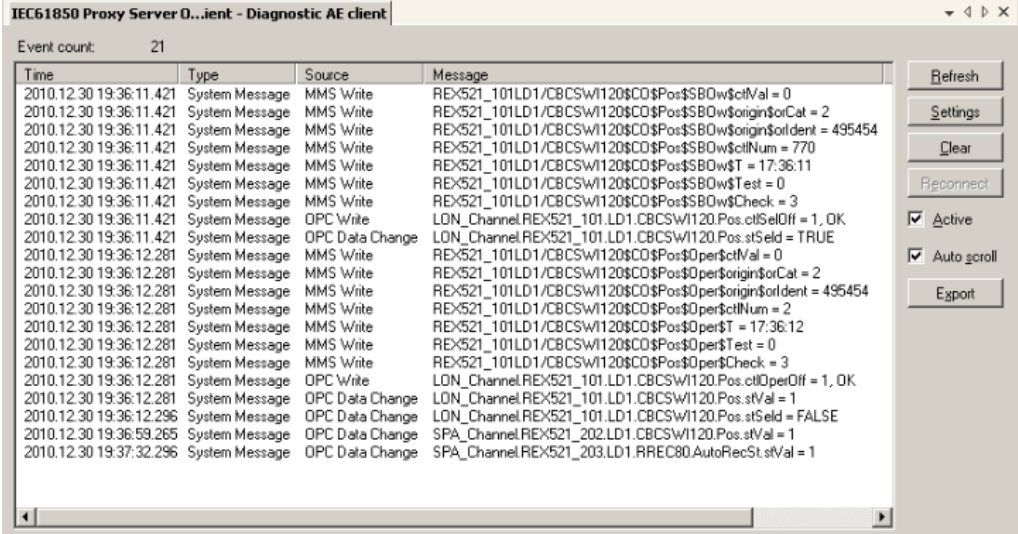

IEC61850 Proxy Server Diagnostic AE client

Event count: 21

Time	Type	Source	Message
2010.12.30 19:36:11.421	System Message	MMS Write	REX521_101LD1/CBCSW1120\$CO\$Pos\$SBOW\$ctVal = 0
2010.12.30 19:36:11.421	System Message	MMS Write	REX521_101LD1/CBCSW1120\$CO\$Pos\$SBOW\$origin\$orCat = 2
2010.12.30 19:36:11.421	System Message	MMS Write	REX521_101LD1/CBCSW1120\$CO\$Pos\$SBOW\$origin\$orIdent = 495454
2010.12.30 19:36:11.421	System Message	MMS Write	REX521_101LD1/CBCSW1120\$CO\$Pos\$SBOW\$ctNum = 770
2010.12.30 19:36:11.421	System Message	MMS Write	REX521_101LD1/CBCSW1120\$CO\$Pos\$SBOW\$T = 17:36:11
2010.12.30 19:36:11.421	System Message	MMS Write	REX521_101LD1/CBCSW1120\$CO\$Pos\$SBOW\$Test = 0
2010.12.30 19:36:11.421	System Message	MMS Write	REX521_101LD1/CBCSW1120\$CO\$Pos\$SBOW\$Check = 3
2010.12.30 19:36:11.421	System Message	OPC Write	LON_ChannelREX521_101.LD1.CBCSW1120.Pos.stSelOff = 1, OK
2010.12.30 19:36:12.281	System Message	OPC Data Change	LON_ChannelREX521_101.LD1.CBCSW1120.Pos.stSel = TRUE
2010.12.30 19:36:12.281	System Message	MMS Write	REX521_101LD1/CBCSW1120\$CO\$Pos\$Oper\$ctVal = 0
2010.12.30 19:36:12.281	System Message	MMS Write	REX521_101LD1/CBCSW1120\$CO\$Pos\$Oper\$origin\$orCat = 2
2010.12.30 19:36:12.281	System Message	MMS Write	REX521_101LD1/CBCSW1120\$CO\$Pos\$Oper\$origin\$orIdent = 495454
2010.12.30 19:36:12.281	System Message	MMS Write	REX521_101LD1/CBCSW1120\$CO\$Pos\$Oper\$ctNum = 2
2010.12.30 19:36:12.281	System Message	MMS Write	REX521_101LD1/CBCSW1120\$CO\$Pos\$Oper\$T = 17:36:12
2010.12.30 19:36:12.281	System Message	MMS Write	REX521_101LD1/CBCSW1120\$CO\$Pos\$Oper\$Test = 0
2010.12.30 19:36:12.281	System Message	MMS Write	REX521_101LD1/CBCSW1120\$CO\$Pos\$Oper\$Check = 3
2010.12.30 19:36:12.281	System Message	OPC Write	LON_ChannelREX521_101.LD1.CBCSW1120.Pos.ctOperOff = 1, OK
2010.12.30 19:36:12.281	System Message	OPC Data Change	LON_ChannelREX521_101.LD1.CBCSW1120.Pos.stVal = 1
2010.12.30 19:36:12.296	System Message	OPC Data Change	LON_ChannelREX521_101.LD1.CBCSW1120.Pos.stSel = FALSE
2010.12.30 19:36:59.265	System Message	OPC Data Change	SPA_ChannelREX521_202.LD1.CBCSW1120.Pos.stVal = 1
2010.12.30 19:37:32.296	System Message	OPC Data Change	SPA_ChannelREX521_203.LD1.RREC80.AutoRecSt.stVal = 1

Buttons: Refresh, Settings, Clear, Reconnect, Active (checked), Auto_scroll (checked), Export

Proxy_diagnostic_AE_client.png

Figure 4.3.1.2-1 IEC 61850 Proxy Server Diagnostic AE client

4.3.2. IEC 61850 Proxy IED

4.3.3. Online diagnostics

The IEC 61850 communication activity can be monitored with the Online diagnostics function, see Figure 4.3.3-1:

- In the Status information field, you can monitor the device status.
- In the Diagnostic counters field, you can monitor the communication activity. The available attributes can be seen in Figure 4.3.3-1.
- To reset Diagnostic counters, click **Reset counters**.
- To take the IEC 61850 communication into use, select the **In use** checkbox. To take the communication out of use, clear the checkbox.
- Diagnostic counters are updated every 2 seconds. To update them manually, click **Refresh**.

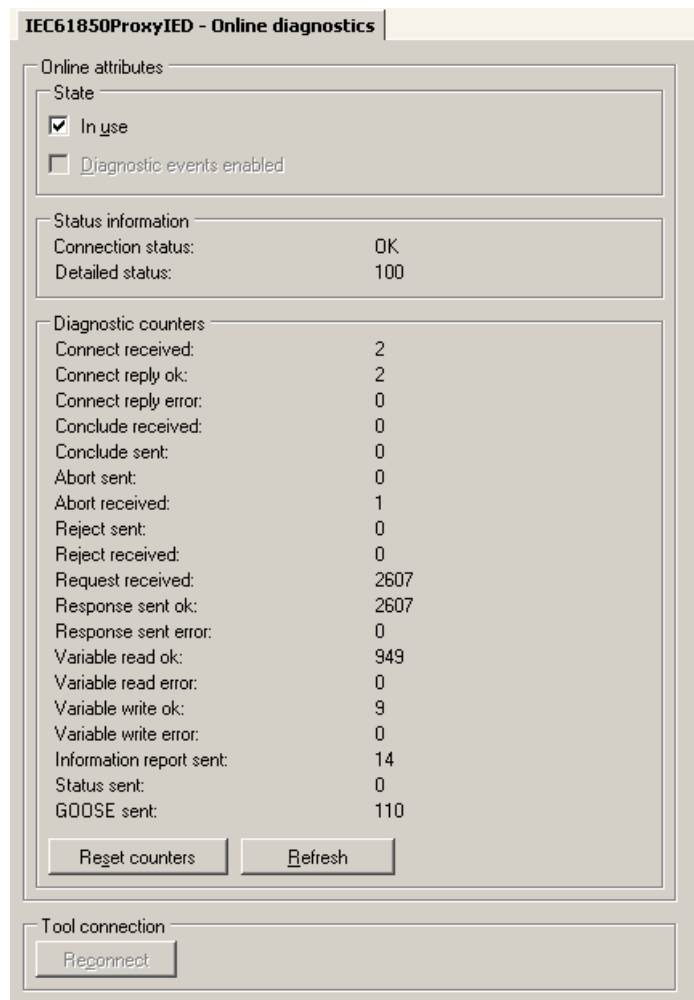

IED_online_diagnostics.png

Figure 4.3.3-1 IEC 61850 Proxy IED online diagnostics

5. Technical reference

5.1. ASCI conformance statement

5.1.1. ASCI conformance statement

ACSI conformance statements shall be used to provide an overview and details about a device claiming conformance with ACSI:

- 5.1.2, ACSI basic conformance statement
- 5.1.3, ACSI models conformance statement
- 5.1.4, ACSI service conformance statement

These statements are used to specify the communication features mapped to an SCSM. The following tables provide the ACSI conformance statements for the COM600 IEC 61850 Proxy Server. The tables are according to IEC 61850-7-2.

5.1.2. ACSI basic conformance statement

Table 5.1.2-1 Basic conformance statement

		Client/Sub- subscriber	Server/Pub- lisher	Value/Comments
	Client-Server roles			
B11	Server side (of TWO-PARTY-APPLICATION-ASSOCIATION)	-	c1	SUPPORTED
B12	Client side of (TWO-PARTY-APPLICATION-ASSOCIATION)	c1	-	
	SCSMs supported			
B21	SCSM: IEC 6185-8-1 used			SUPPORTED
B22	SCSM: IEC 6185-9-1 used			-
B23	SCSM: IEC 6185-9-2 used			-
B24	SCSM: other			-
	Generic substation event model (GSE)			
B31	Publisher side	-	O	SUPPORTED
B32	Subscriber side	O	-	-
	Transmission of sampled value model (SVC)			
B41	Publisher side	-	O	-
B42	Subscriber side	O	-	-

c1 – shall be ‘M’ if support for LOGICAL-DEVICE model has been declared.

O – Optional

M – Mandatory

5.1.3.

ACSI models conformance statement

Table 5.1.3-1 ACSI models conformance statement

		Client/Sub- subscriber	Server/Pub- lisher	Value/Comments
	If Server side (B1) supported			
M1	Logical device	c2	c2	SUPPORTED
M2	Logical node	c3	c3	SUPPORTED
M3	Data	c4	c4	SUPPORTED
M4	Data set	c5	c5	SUPPORTED
M5	Substitution	O	O	-
M6	Setting group control	O	O	-
	Reporting			
M7	Buffered report control	O	O	SUPPORTED
M7-1	sequence-number			
M7-2	report-time-stamp			
M7-3	reason-for-inclusion			
M7-4	data-set-name			
M7-5	data-reference			
M7-6	buffer-overflow			
M7-7	entryID			
M7-8	BufTm			
M7-9	IntgPd			
M7-10	GI			
M7-11	conf-revision			
M8	Unbuffered report control	O	O	SUPPORTED
M8-1	sequence-number			
M8-2	report-time-stamp			
M8-3	reason-for-inclusion			
M8-4	data-set-name			
M8-5	data-reference			

		Client/Sub- scriber	Server/Pub- lisher	Value/Comments
M8-6	BufTm			
M8-7	IntgPd			
M8-8	GI			
M8-9	conf-revision			
	Logging	O	O	-
M9	Log control	O	O	-
M9-1	IntgPd			
M10	Log	O	O	-
M11	Control	M	M	SUPPORTED
	If GSE (B31/32) is supported			
	GOOSE	O	O	SUPPORTED (send)
M13	GSSE	O	O	
	If SVC (41/42) is supported			
M14	Multicast SVC	O	O	-
M15	Unicast SVC	O	O	-
M16	Time	M	M	-
M17	File Transfer	O	O	-

c1 – shall be ‘M’ if support for LOGICAL-DEVICE model has been declared.

c2 – shall be ‘M’ if support for LOGICAL-NODE model has been declared.

c3 – shall be ‘M’ if support for DATA model has been declared.

c4 – shall be ‘M’ if support for DATA-SET, Substitution, Report, Log Control, or Time model has been declared.

c5 – shall be ‘M’ if support for Report, GSE, or SMV models has been declared.

M - Mandatory

5.1.4.

ACSI service conformance statement

The ACSI service conformance statement shall be as defined in Table 5.1.4-1 (depending on the statements in Table 5.1.3-1).

Table 5.1.4-1 ACSI service Conformance statement

	Services	AA: TP/MC	Client/Sub- scriber	Server/Pub- lisher	Value/Comments
	Server				
S1	ServerDirectory	TP		M	SUPPORTED
	Application association				
S2	Associate		M	M	SUPPORTED
S3	Abort		M	M	SUPPORTED
S4	Release		M	M	SUPPORTED
	Logical device				
S5	LogicalDeviceDirectory	TP	M	M	SUPPORTED
	Logical node				
S6	LogicalNodeDirectory	TP	M	M	SUPPORTED
S7	GetDataValues	TP	O	M	SUPPORTED
	Data				
S8	GetDataValues	TP	M	M	SUPPORTED
S9	SetDataValues	TP	O	O	SUPPORTED
S10	GetDataDirectory	TP	O	M	SUPPORTED
S11	GetDataDefinition	TP	O	M	SUPPORTED
	Data set				
S12	GetDataSetValues	TP	O	M	SUPPORTED
S13	SetDataSetValues	TP	O	O	-
S14	CreateDataSet	TP	O	O	-
S15	DeleteDataSet	TP	O	O	-
S16	GetDataSetDirectory	TP	O	O	SUPPORTED
	Substitution				
S17	SetDataValues	TP	M	M	SUPPORTED
	Setting group control				
S18	SelectActiveSG	TP	O	O	-
S19	SelectEditSG	TP	O	O	-
S20	SetSGValues	TP	O	O	-
S21	ConfirmEditSGValues	TP	O	O	-
S22	GetSGValues	TP	O	O	-
S23	GetSGCBValues	TP	O	O	-
	Reporting				

	Services	AA: TP/MC	Client/Sub- scriber	Server/Pub- lisher	Value/Comments
	Buffered report control block (BRCB)				
S24	Report	TP	c6	c6	SUPPORTED
S24-1	data-change (dchg)				
S24-2	qchg-change (qchg)				
S24-3	data-update (dupd)				
S25	GetBRCBValues	TP	c6	c6	SUPPORTED
S26	SetBRCBValues	TP	c6	c6	SUPPORTED
	Unbuffered report control block (URCB)				
S27	Report	TP	c6	c6	SUPPORTED
S27-1	data-change (dchg)				
S27-2	qchg-change (qchg)				
S27-3	data-update (dup)				
S28	GetURCBValues	TP	c6	c6	SUPPORTED
S29	SetURCBValues	TP	c6	c6	SUPPORTED
	Logging				
	Logging control block				
S30	GetLCBValues	TP	M	M	-
S31	SetLCBValues	TP	O	M	-
	Log				
S32	QueryLogByTime	TP	c7	M	-
S33	QueryLogByEntry	TP	c7	M	-
S34	GetLogStatusValues	TP	M	M	-
	Generic substation event model (GSE)				
	GOOSE-CONTROL-BLOCK				
S35	SendGOOSEMessage	MC	c8	c8	SUPPORTED
S36	GetReference	TP	O	c9	-
S37	GetGOOSEElementNumber	TP	O	c9	-
S38	GetGoCBValues	TP	O	O	-
S39	SetGoCBValues	TP	O	O	-
	GSSE-CONTROL-BLOCK				
S40	SendGSSEMessage	MC	c8	c8	-
S41	GetReference	TP	O	c9	-

	Services	AA: TP/MC	Client/Sub- scriber	Server/Pub- lisher	Value/Comments
S42	GetGSSEElementNumber	TP	O	c9	-
S43	GetGsCBValues	TP	O	O	-
S44	SetGsCBValues	TP	O	O	-
	Transmission of sampled value model (SVC)				
	Multicast SVC				
S45	SendMSVMessage	MC	c10	c10	-
S46	GetMSVCBValues	TP	O	O	-
S47	SetMSVCBValues	TP	O	O	-
	Unicast SVC				
S48	SendUSVMessage	TP	c10	c10	-
S46	GetUSVCBValues	TP	O	O	-
S47	SetMSVCBValues	TP	O	O	-
	Control				
S51	Select		M	M	SUPPORTED
S52	SelectWithValue	TP	M	M	SUPPORTED
S53	Cancel	TP	O	M	SUPPORTED
S54	Operate	TP	M	M	SUPPORTED
S55	Command-Termination	TP	M	M	SUPPORTED
S56	TimeActivated-Operate	TP	O	O	-
	File transfer				
S57	GetFile	TP	O	M	-
S58	SetFile	TP	O	O	-
S59	DeleteFile	TP	O	O	-
S60	GetFileAttributeValues	TP	O	M	-
	Time				
T1	Time resolution of internal clock				(nearest negative power of 2 in seconds)
T2	Time accuracy of internal clock				T0
					T1
					T2
					T3
					T4

	Services	AA: TP/MC	Client/Sub- scriber	Server/Pub- lisher	Value/Comments
					T5
T3	supported TimeStamp resolution				(nearest negative power of 2 in seconds)

c6 – shall declare support for at least one (BRCB or URCB).

c7 – shall declare support for at least one (QueryLogByTime or QueryLogByEntry).

c8 – shall declare support for at least one (SendGOOSEMessage or SendGSSEMessage).

c9 – shall declare support if TP association is available.

c10 – shall declare support for at least one (SendMSVMessage or SendUSVMessage).

5.2. SCL conformance

5.2.1. SCL conformance statement

The SCL conformance statement defines several degrees of conformance for which implementations may declare support of the substation configuration language. [1]

Table 5.2.1-1 SCL conformance degrees

	SCL Conformance	Client- CR		Value/Range	Server- CR		Value/Range
		Base	F/S		Base	F/S	
SCL.1	SCL File for Implementation Available (offline)				M	M	SUPPOR- TED
SCL.2	SCL File available from implementation online	O	O		O	O	-
SCL.3	SCL implementation reconfiguration supported online	O	O		O	O	-

5.3. PICS - protocol conformance statement

5.3.1. Profile conformance

Table 5.3.1-1 and Table 5.3.1-2 define the basic conformance statement.

Table 5.3.1-1 PICS for A-Profile support

		Client		Server		Value/Comment
		F/S		F/S		
A1	Client/Server A-Profile	c1		c1		SUPPORTED
A2	GOOSE/GSE Management A-Profile	c2		c2		SUPPORTED
A3	GSSE A-Profile	c3		c3		-
A4	TimeSync A-Profile	c4		c4		-

c1 – shall be ‘m’ if support for any service specified for Client/S are declared within the ACSI basic conformance statement.

c2 – shall be ‘m’ if support for any service specified for GOOSE/GSE Management are declared within the ACSI basic conformance statement.

c3 – shall be ‘m’ if support for any service specified for GSSE A-Profile are declared within the ACSI basic conformance statement.

c4 – support for at least one other A-Profile shall be declared (e.g. in A1-A3) in order to claim conformance to IEC 61850-8-1.

Table 5.3.1-2 PICS for T-Profile support

		Client		Server		Value/Comment
		F/S		F/S		
T1	TCP/IP T-Profile	c1		c1		SUPPORTED
T2	OSI T-Profile	c2		c2		-
T3	GOOSE/GSE T-Profile	c3		c3		SUPPORTED
T4	GSSE T-Profile	c4		c4		-
T5	TimeSync T-Profile	o		o		-

c1 – shall be ‘m’ if support for A1 is declared. Otherwise, shall be “i”

c2 – shall be “o” if support for A1 is declared. Otherwise, shall be “i”.

c3 – shall be ‘m’ if support for A2 is declared. Otherwise, shall be “i”.

c4 – shall be ‘m’ if support for A3 is declared. Otherwise, shall be “i”.

5.3.2.

MMS Conformance

MMS conformance is guaranteed by MMS stack vendor, i.e. Systems Integration Specialists Company, Inc. (SISCO).

All required IEC 61850 services for supporting the ACSI services stated to be supported are supported by the used MMS stack MMS-EASE Light.

Index

A

ACSI conformance	35
basic conformance	35
models conformance	36
service conformance	37
adding	
IEC 61850 Proxy Server OPC Client	15

B

building object tree	14
IEC 61850 Proxy Server OPC Client	15

C

configuring	
GOOSE publishing	25
IEC 61850 Proxy IED	29
IEC 61850 Proxy Subnetwork	28
object	27
overview	13
reporting	22

D

data reporting	18
configuring	22
report control block	18
data set	16
configuring	16
reporting	18, 22
Dataset Editor	16
diagnostuc AE client	32

F

features	12
----------------	----

G

GOOSE	23
publishing	25

I

IEC 61850 Proxy Server	28
features	12
IEC 61850 Proxy Server OPC Client adding	15

O

object configuring	27
online diagnostics	31, 33

P

Proxy Configuration Tool	15
--------------------------------	----

R

report control block	18
----------------------------	----

S

SCL conformance	41
-----------------------	----

Contact us

ABB Oy

Distribution Automation

P.O. Box 699

FI-65101 VAASA, FINLAND

Tel. +358 10 22 11

Fax. +358 10 224 1094

ABB Inc.

Distribution Automation

655 Century Point

Lake Mary, FL 32746, USA

Tel: +1 407 732 2000

Fax: +1 407 732 2335

www.abb.com/substationautomation