

Directional or Non-Directional Earth-Fault Relay REJ 527

Technical Reference Manual



ABB

Contents

1. About this manual	5
1.1. Copyrights	5
1.2. Trademarks	5
1.3. Guarantee	5
1.4. General	5
1.5. Use of symbols	6
1.6. Terminology	6
1.7. Related documents	6
1.8. Document revisions	6
2. Safety Information	7
3. Introduction	9
3.1. Use of the relay	9
3.2. Features	9
4. Instructions	11
4.1. Application	11
4.2. Requirements	11
4.3. Configuration	11
5. Technical description	13
5.1. Functional description	13
5.1.1. Product functions	13
5.1.1.1. Schema of product functions	13
5.1.1.2. Earth-fault current, zero-sequence voltage and intermittent earth-faults	13
5.1.1.3. Inputs	14
5.1.1.4. Outputs	14
5.1.1.5. Circuit-breaker failure protection unit	14
5.1.1.6. Disturbance recorder	14
5.1.1.7. HMI module	14
5.1.1.8. Non-volatile memory	15
5.1.1.9. Self-supervision	15
5.1.2. Measurements	15
5.1.3. Configuration	16
5.1.4. Protection	17
5.1.4.1. Block diagram	17
5.1.4.2. Directional or non-directional earth-fault current unit	17
5.1.4.3. Zero-sequence voltage unit	21
5.1.4.4. Protection against intermittent earth-faults	22
5.1.4.5. Time/current characteristics	23

5.1.4.6.	Settings	32
5.1.4.7.	Technical data on protection functions	40
5.1.5.	Indicator LEDs and alarm indication messages	41
5.1.6.	Commissioning test	42
5.1.7.	Disturbance recorder	42
5.1.7.1.	Function	42
5.1.7.2.	Disturbance recorder data	42
5.1.7.3.	Control and indication of disturbance recorder status	43
5.1.7.4.	Triggering	44
5.1.7.5.	Settings and unloading	44
5.1.7.6.	Event code of the disturbance recorder	44
5.1.8.	Recorded data of the last events	44
5.1.9.	External serial communication	45
5.1.9.1.	Communication ports	45
5.1.9.2.	IEC 60870-5-103 remote communication protocol	46
5.1.9.3.	Event codes	51
5.1.9.4.	SPA bus communication protocol parameters ..	52
5.1.10.	Self-supervision (IRF) system	59
5.1.11.	Relay parameterization	59
5.2.	Design description	59
5.2.1.	Input/output connections	59
5.2.2.	Serial communication connections	62
5.2.3.	Technical data	63
6.	Ordering information	67
7.	Abbreviations	69
8.	Check lists	71
9.	Service	75
10.	Index	77

1. About this manual

1.1. Copyrights

The information in this document is subject to change without notice and should not be construed as a commitment by ABB Oy. ABB Oy assumes no responsibility for any errors that may appear in this document.

In no event shall ABB Oy be liable for direct, indirect, special, incidental or consequential damages of any nature or kind arising from the use of this document, nor shall ABB Oy be liable for incidental or consequential damages arising from use of any software or hardware described in this document.

This document and parts thereof must not be reproduced or copied without written permission from ABB Oy, and the contents thereof must not be imparted to a third party nor used for any unauthorized purpose.

The software or hardware described in this document is furnished under a license and may be used, copied, or disclosed only in accordance with the terms of such license.

Copyright © 2005 ABB Oy
All rights reserved.

1.2. Trademarks

ABB is a registered trademark of ABB Group.

All other brand or product names mentioned in this document may be trademarks or registered trademarks of their respective holders.

1.3. Guarantee

Please inquire about the terms of guarantee from your nearest ABB representative.

1.4. General

The purpose of this manual is to provide the user with thorough information on the protection relay REJ 527 and its applications, focusing on giving a technical description of the relay.

Refer to the Operator's Manual for instructions on how to use the Human-Machine Interface (HMI) of the relay, also known as the Man-Machine Interface (MMI), and to the Installation Manual for installation of the relay.

1.5. Use of symbols

This document includes warning, caution, and information icons that point out safety-related conditions or other important information. The corresponding icons should be interpreted as follows:



The electrical warning icon indicates the presence of a hazard which could result in electrical shock.



The caution icon indicates important information or warning related to the concept discussed in the text. It might indicate the presence of a hazard which could result in corruption of software or damage to equipment or property.



The information icon alerts the reader to relevant facts and conditions.

Although warning hazards are related to personal injury, and caution hazards are associated with equipment or property damage, it should be understood that operation of damaged equipment could, under certain operational conditions, result in degraded process performance leading to personal injury or death. Therefore, comply fully with all warning and caution notices.

1.6. Terminology

The following is a list of terms that you should be familiar with. The list contains terms that are unique to ABB or have a usage or definition that is different from standard industry usage.

Term	Description
IEC_103	IEC 60870-5-103, a communication protocol standardized by the International Electrotechnical Commission
SPA	A data communication protocol developed by ABB



1.7. Related documents

Name of the manual	MRS number
REJ 527 Operator's Manual	1MRS751055-MUM
RE_5__ Installation Manual	1MRS750526-MUM

1.8. Document revisions

Version	Date	History
B	05.07.2002	
C	14.11.2005	Relay face plate updated. Manual layout updated.

2. Safety Information

	Dangerous voltages can occur on the connectors, even though the auxiliary voltage has been disconnected.
	Non-observance can result in death, personal injury or substantial property damage.
	Only a competent electrician is allowed to carry out the electrical installation.
	National and local electrical safety regulations must always be followed.
	The frame of the device has to be carefully earthed.
	The device contains components which are sensitive to electrostatic discharge. Unnecessary touching of electronic components must therefore be avoided.
	Breaking the sealing tape on the rear panel of the device will result in loss of warranty and proper operation will no longer be guaranteed.

3. Introduction

3.1. Use of the relay

The directional or non-directional earth-fault relay REJ 527 is intended for earth-fault protection in medium voltage distribution networks but can also be used for protection of generators, motors and transformers.

The REJ 527 is based on a microprocessor environment. A self-supervision system continuously monitors the operation of the relay.

The HMI includes a Liquid Crystal Display (LCD) which makes the local use of the relay safe and easy.

Local control of the relay via serial communication can be carried out with a portable computer connected to the front connector and remote control via the rear connector connected to the distribution automation system through the serial interface and the fibre-optic bus.

3.2. Features

- Directional or non-directional low-set earth-fault current stage with definite-time or inverse definite minimum time (IDMT) characteristic
- Directional or non-directional high-set earth-fault current stage with definite-time characteristic
- Deblocking zero-sequence voltage stage with definite-time characteristic
- The two earth-fault current stages can be configured to operate alternatively as two voltage stages: three-stage voltage monitoring operation possible
- Intermittent earth-fault protection
- Circuit-breaker failure protection (CBFP)
- Disturbance recorder
 - recording time up to 19 seconds
 - triggering by a start or a trip signal from any protection stage and/or by a binary input signal
 - records two analogue channels and seven digital channels
 - adjustable sampling rate
- Non-volatile memory for
 - up to 60 event codes
 - setting values
 - disturbance recorder data
 - recorded data of the five last events with time stamp
 - number of starts for each stage
 - alarm indication messages and LEDs showing the status at the moment of power failure
- Two accurate measuring inputs
- Galvanically isolated binary input with a wide input voltage range

-
- All settings can be modified with a personal computer
 - HMI with an alphanumeric LCD and manoeuvring buttons
 - IEC 60870-5-103 and SPA bus communication protocols
 - Two normally open power output contacts
 - Two change-over signal output contacts
 - Output contact functions freely configurable for desired operation
 - Optical PC-connector for two-way data communication (front)
 - RS-485 connector (rear) for system communication
 - Continuous self-supervision of electronics and software. At an internal relay fault (IRF), all protection stages and outputs are blocked.
 - User-selectable rated frequency 50/60 Hz
 - User-selectable password protection for the HMI
 - Display of primary current and voltage values as well as phase angle values
 - Multi-language support

4. Instructions

4.1. Application

The directional or non-directional earth-fault relay REJ 527 is a secondary relay which is connected to the voltage and current transformers of the object to be protected. The earth-fault current and the zero-sequence voltage unit continuously measure the zero-sequence voltage, earth-fault current and phase angle of the object. On detection of a fault, the relay will start, trip the circuit breaker, provide alarms, record fault data, etc., in accordance with the application and the configured relay functions.

The voltage unit includes low-set stage $U_{0b}>$ and the earth-fault current unit low-set stage $I_0>$ and high-set stage $I_0>>$. The earth-fault stages can be replaced by two additional voltage stages, low-set stage $U_0>$ and high-set stage $U_0>>$.

The protection functions are independent of each other and have their own setting groups and data recordings. The voltage and current functions use conventional transformer measurement.

An output contact matrix allows start or trip signals from the protection stages to be routed to the desired output contact.

4.2. Requirements

When the REJ 527 is operating under the conditions specified below (see also "Technical data"), it will be practically maintenance-free. The relay includes no parts or components subject to abnormal physical or electrical wear under normal operating conditions.

Environmental conditions

- | | |
|--|-------------|
| • Specified ambient service temperature range | -10...+55°C |
| • Temperature influence on the operation accuracy of the protection relay within the specified ambient service temperature range | 0.1% / °C |
| • Transport and storage temperature range | -40...+70°C |

4.3. Configuration

Setting and connection example

The appropriate configuration of the output contact matrix enables the use of the signals from the earth-fault current and the voltage unit as contact functions. The start signals can be used for blocking co-operating protection relays, signalling and initiating autoreclosing.

Figure 4.3.-1 represents the REJ 527 with the default configuration: all trips are routed to trip the circuit breaker.

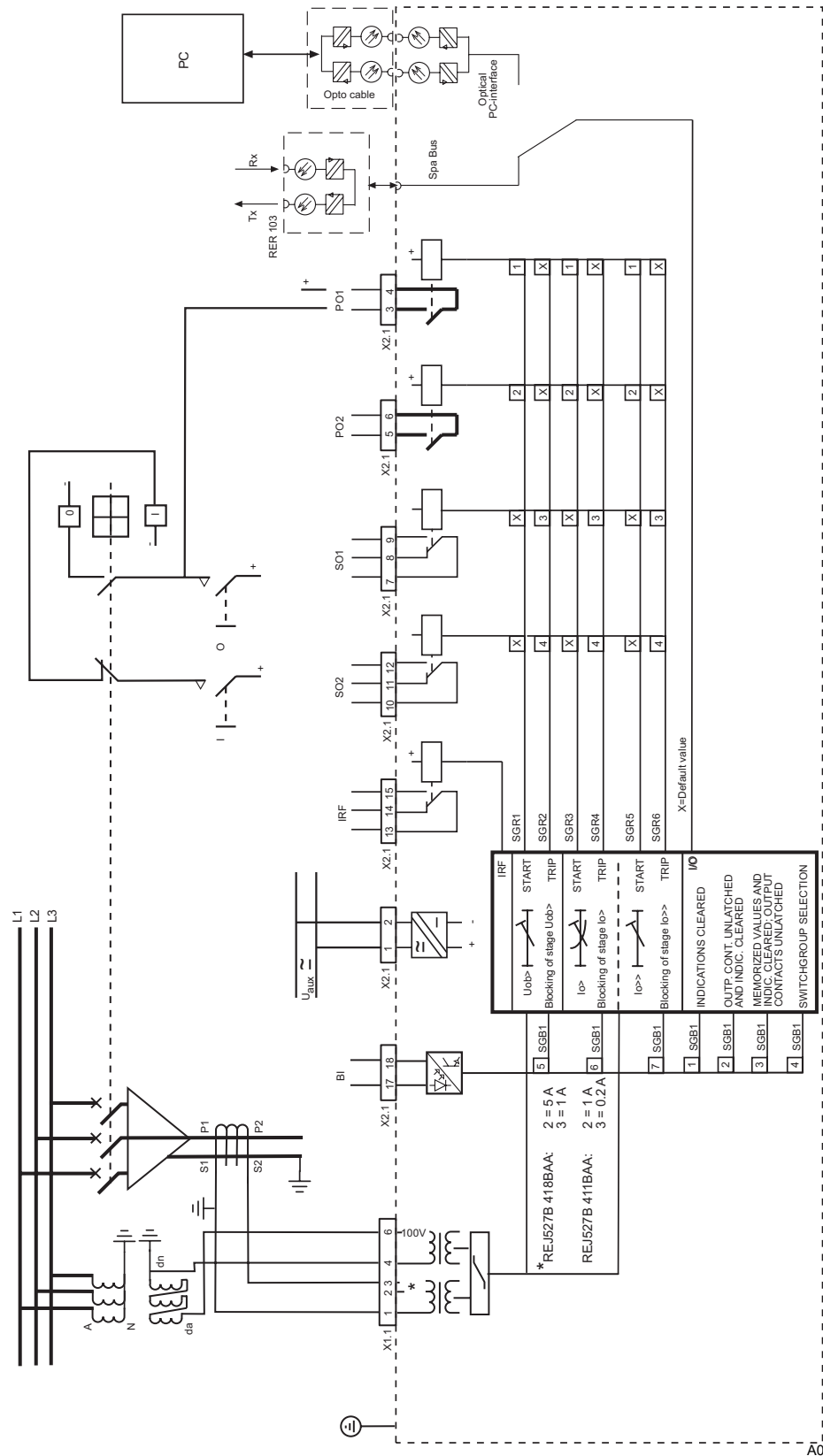

A0501420

Fig. 4.3.-1 Connection diagram of the directional earth-fault relay

5. Technical description

5.1. Functional description

5.1.1. Product functions

5.1.1.1. Schema of product functions

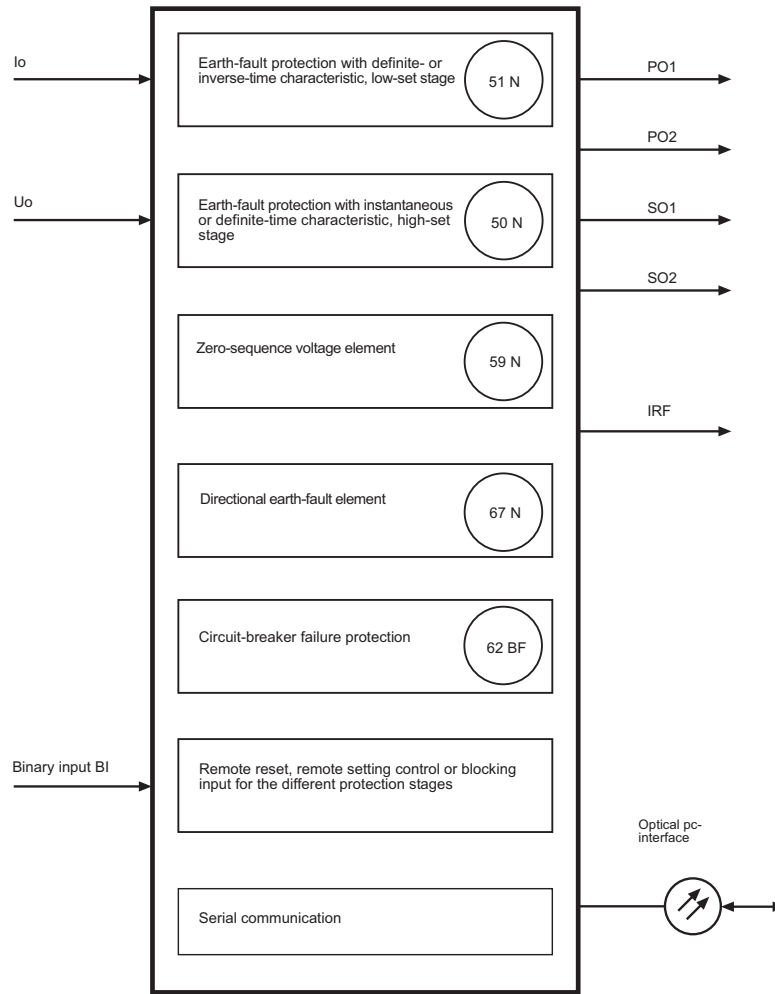

A0501421

Fig. 5.1.1.1.-1 Product functions

5.1.1.2. Earth-fault current, zero-sequence voltage and intermittent earth-faults

Refer to sections:

- 5.1.4.2. “Directional or non-directional earth-fault current unit”
- 5.1.4.3. “Zero-sequence voltage unit”
- 5.1.4.4. “Protection against intermittent earth-faults”

5.1.1.3.**Inputs**

The REJ 527 includes two energizing inputs and one external binary input controlled by an external voltage. For details, refer to section Input/output connections and tables 5.1.4.6-7, 5.2.1-1 and 5.2.1-5. The function of the binary input is determined using the SGB switches.

5.1.1.4.**Outputs**

The REJ 527 is provided with two power outputs (PO1 and PO2) and two signal outputs (SO1 and SO2). Switchgroups SGR1...6 are used for routing start and trip signals from the protection stages to the desired signal or power output. PO1 and PO2 can be configured to be latched and the minimum pulse length to 40 or 80 ms.

5.1.1.5.**Circuit-breaker failure protection unit**

The REJ 527 features a circuit-breaker failure protection (CBFP) unit. The CBFP unit will generate a trip signal via output PO2 if the fault has not been cleared on expiration of the set operate time 0.10 s...1.00 s.

Normally, the CBFP unit controls the upstream circuit breaker. It can also be used for tripping via redundant trip circuits of the same circuit breaker. The CBFP unit is activated with a switch of switchgroup SGF1.

5.1.1.6.**Disturbance recorder**

The REJ 527 includes an internal disturbance recorder which records the momentary measured values, or the RMS curves of the measured signals, and seven digital signals: the external binary input signal and the states of the internal protection stages. The disturbance recorder can be set to be triggered by a start or a trip signal from any protection stage and/or by an external binary input signal, and either on the falling or rising triggering edge.

5.1.1.7.**HMI module**

The HMI of the REJ 527 is equipped with six push-buttons and an alphanumeric 2x16 characters' LCD. The push-buttons are used for navigating in the menu structure and for adjusting set values.

An HMI password can be set to protect all user-changeable values from being changed by an unauthorised person. The HMI password will remain inactive and will thus not be required for altering parameter values until the default HMI password has been replaced. Entering the HMI password successfully can be selected to generate an event code. This feature can be used to indicate interaction activities via the local HMI. For further information on the HMI, refer to the Operator's Manual.

5.1.1.8. Non-volatile memory

The REJ 527 can be configured to store various data in the non-volatile memory, which will retain its data also in case of loss of auxiliary voltage. Alarm indication messages and LEDs, the number of starts, disturbance recorder data, event codes and recorded data can all be configured to be stored in the non-volatile memory whereas setting values will always be stored.

5.1.1.9. Self-supervision

The self-supervision system of the REJ 527 manages run-time fault situations and informs the user about an existing fault. When the self-supervision system detects a permanent internal relay fault, the READY indicator LED will start to blink. At the same time the self-supervision alarm relay (also referred to as the IRF relay), which is normally picked up, will drop off and a fault code will appear on the LCD. The fault code is numerical and identifies the fault type. For fault codes, refer to section Internal fault in the Operator's Manual.

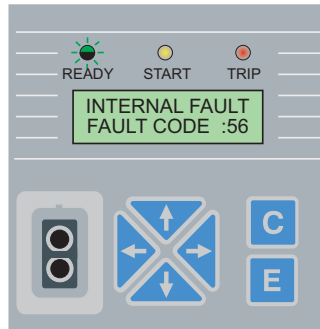

A501289

Fig. 5.1.1.9.-1 Internal fault

Fault codes can indicate:

- no response on the output contact test
- faulty program, work or parameter memory
- internal reference voltage error

5.1.2. Measurements

The table below presents the measured values which can be accessed through the HMI. The measured voltage is shown as a percentage of the rated voltage, U_n , and the measured currents of the rated current, I_n , of the energizing input. The phase angle is shown in degrees and can be selected to be shown either as the angle between the voltage and the current or as the angle between the basic angle and the current with switch SGF3/8. If the measured current and voltage values are too low, i.e. lower than 0.50 percent, dashes will be shown on the LCD.

Table 5.1.2-1 Measured values

Indicator	Measured data
U_0	Zero-sequence voltage
I_0	Earth-fault current
I_φ	Directional earth-fault current
j	Phase angle

5.1.3.

Configuration

The figure below illustrates how the start, trip and binary input signals can be configured to obtain the required protection functionality.

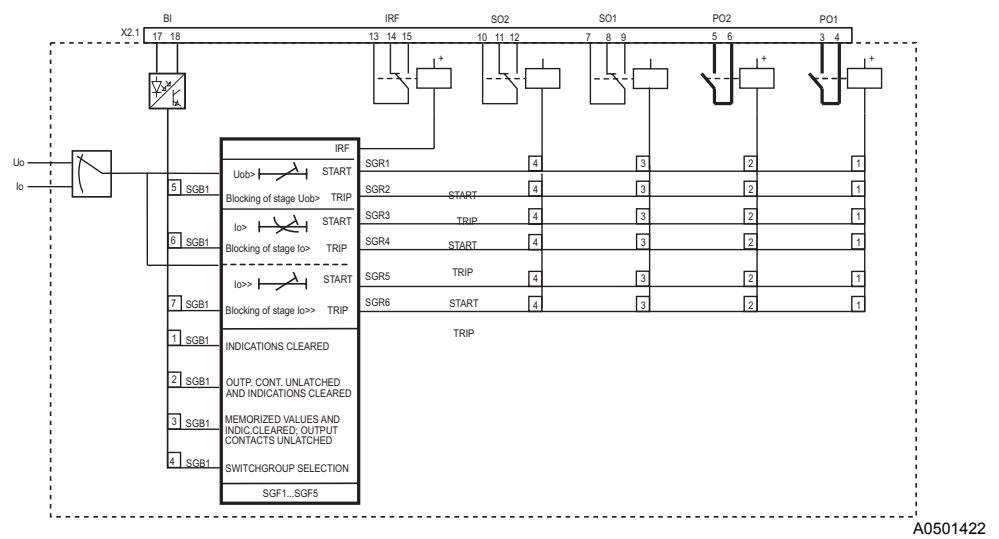
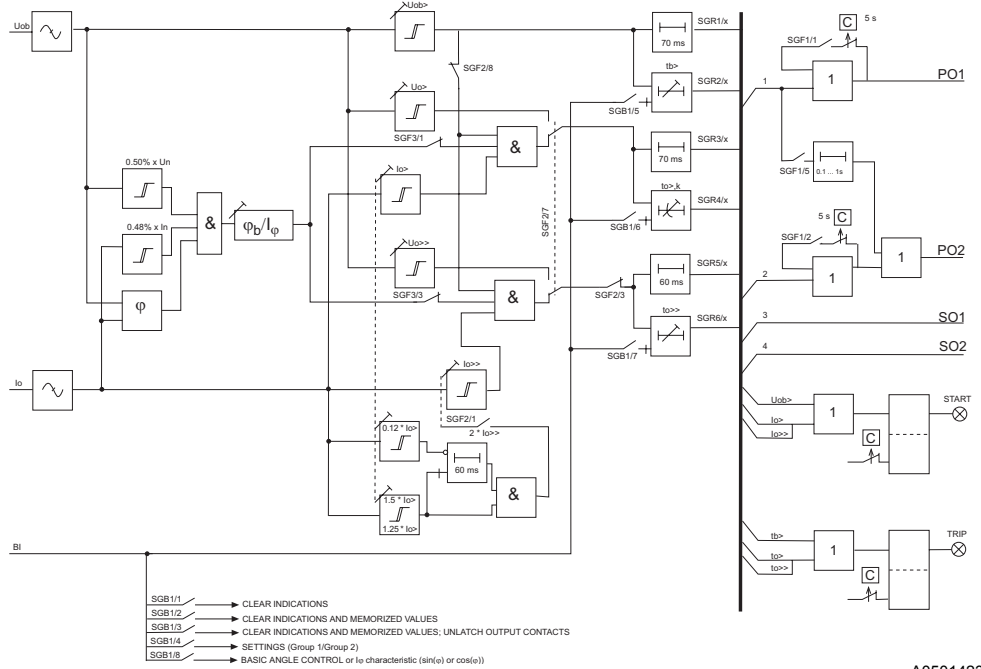

Fig. 5.1.3.-1 Signal diagram of the directional earth-fault relay

The functions of the blocking and start signals are selected with the switches of switchgroups SGF, SGB and SGR. The checksums of the switchgroups are found under "SETTINGS" in the HMI menu. The functions of these switches are explained in detail in the corresponding SG_ -tables.

5.1.4. Protection

5.1.4.1. Block diagram



A0501423

Fig. 5.1.4.1.-1 Block diagram of the directional earth-fault relay REJ 527

5.1.4.2. Directional or non-directional earth-fault current unit

The high-set and the low-set stage of the directional earth-fault current unit can be configured to be either directional or non-directional. The directional earth-fault stages can be given either a basic angle or a $\sin(\varphi)$ or a $\cos(\varphi)$ characteristic.

The start and the tripping of the directional earth-fault stages with the basic angle characteristic are based on measuring the earth-fault current, I_0 , the zero-sequence voltage, U_0 , and the phase angle, φ , between the voltage and the current. An earth-fault stage will start when the following three criteria are fulfilled at the same time:

- The earth-fault current, I_0 , exceeds the set start value of the low- or high-set earth-fault stage.
- The zero-sequence voltage, U_0 , exceeds the set start value of $U_{0b>}$, which is the same for both stages in the deblocking mode.
- The phase angle, φ , between the voltage and the current falls within the operation sector $\varphi_b \pm \Delta\varphi$.

The basic angle of the network is -90° for isolated neutral networks and 0° for resonant earthed networks, earthed with an arc suppression coil (Petersen coil) with or without a parallel resistor. The operation sector is selectable and can be either $\Delta\varphi = \pm 80^\circ$ or $\pm 88^\circ$. Both operation sectors can be extended.

When an earth-fault stage starts, a start signal will be generated and a start indication shown on the HMI. If the above mentioned criteria remain fulfilled until the set operate time elapses, the stage will deliver a trip signal and a trip indication will be shown on the HMI. The trip indication will remain active although the protection stage is reset. The direction of the fault spot is determined by means of the angle between the voltage and the current. Basic angle ϕ_b can be set between -90° and 0° . When basic angle ϕ_b is 0° , the negative quadrant of the operation sector can be extended with ϕ_a (see Fig. 5.1.4.2.-1). Extended operation sector ϕ_a can be set between 0 and 90° .

Figures 5.1.4.2.-1, 5.1.4.2.-2 and 5.1.4.2.-3 show examples of the basic angle characteristic.

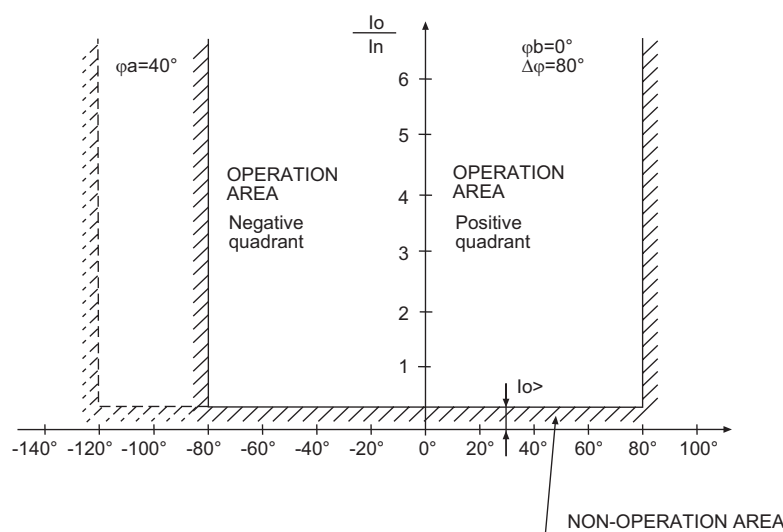

A0501424

Fig. 5.1.4.2.-1 Operation characteristic of the directional earth-fault protection unit when basic angle $\phi_b=0^\circ$, operation sector $\Delta\phi=\pm 80^\circ$ and extended operation sector $\phi_a=40^\circ$

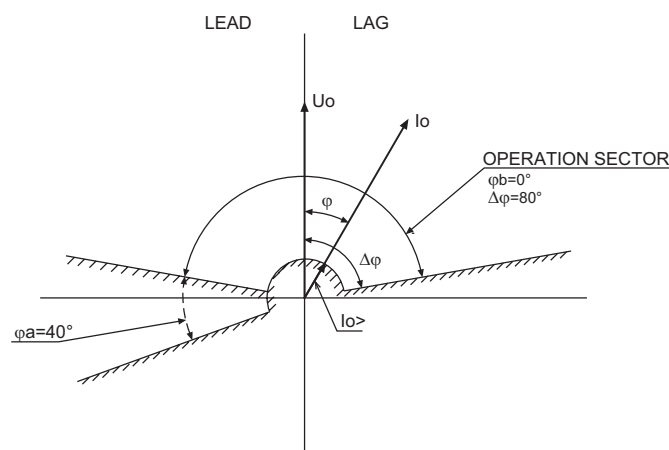

A0501425

Fig. 5.1.4.2.-2 Operation characteristic when basic angle $\phi_b=0^\circ$, operation sector $\Delta\phi=\pm 80^\circ$ and extended operation sector $\phi_a=40^\circ$

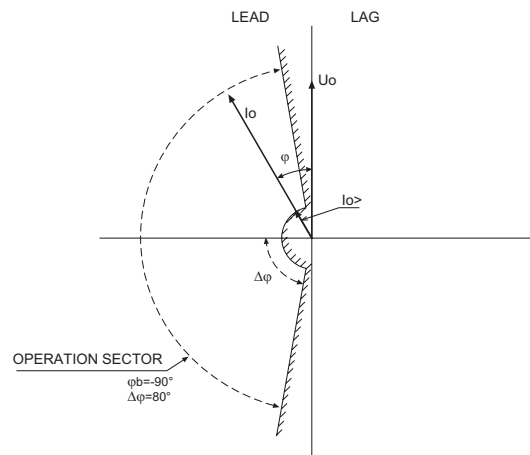

A0501426

Fig. 5.1.4.2.-3 Operation characteristic when basic angle $\varphi_b = -90^\circ$

The start and the tripping of the directional earth-fault stages with the $\sin(\varphi)$ or the $\cos(\varphi)$ characteristic are based on measuring the earth-fault current, I_0 , the zero-sequence voltage, U_0 , and the phase angle, φ , between the voltage and the current. The sinus or cosinus value of the phase angle is calculated and multiplied by the earth-fault current to get the directional earth-fault current, I_φ . An earth-fault stage will start when the following three criteria are fulfilled at the same time:

- The directional earth-fault current, I_φ , exceeds the set start value of the low- or high-set earth-fault stage.
- The zero-sequence voltage, U_0 , exceeds the set start value of $U_{0b>}$, which is the same for both stages in the deblocking mode.
- The phase angle, φ , between the voltage and the current falls within the operation sector, corrected with φ_c .

When an earth-fault stage starts, a start signal will be generated and a start indication shown on the HMI. If the above mentioned criteria remain fulfilled until the set operate time elapses, the stage will deliver a trip signal and a trip indication will be shown on the HMI. The trip indication will remain active although the protection stage is reset. The direction of the fault spot is determined by means of the angle between the voltage and the current. Directional earth-fault characteristic $\sin(\varphi)$ corresponds to the earth-fault protection with the basic angle -90° and $\cos(\varphi)$ to the earth-fault protection with the basic angle 0° .

Figures 5.1.4.2.-4 and 5.1.4.2.-5 show examples of the $\sin(\varphi)$ and the $\cos(\varphi)$ characteristics.

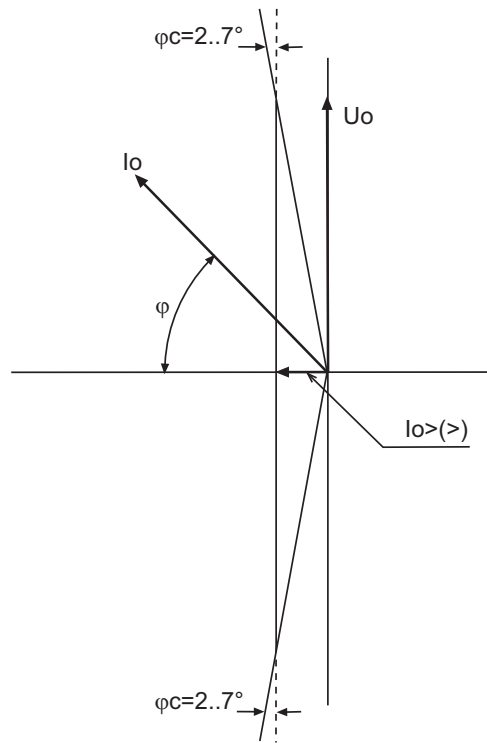

A0501427

Fig. 5.1.4.2.-4 Operation characteristic $\sin(\varphi)$

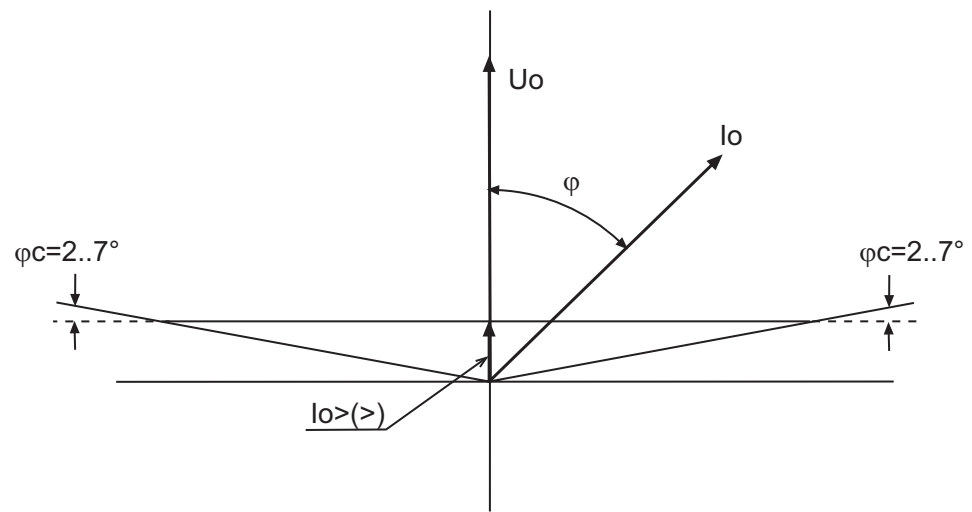

A0501428

Fig. 5.1.4.2.-5 Operation characteristic $\cos(\varphi)$

The operation directions, forward or reverse, of the directional earth-fault stages can be selected independently of each other. The directional stages can also be separately configured to be non-directional.

When the earth-fault current exceeds the set start value of low-set stage $I_{0>}$, the earth-fault unit will start to deliver a start signal after a ~ 70 ms' start time. When the set operate time at definite-time characteristic or the calculated operate time at IDMT characteristic elapses, the earth-fault unit will deliver a trip signal.

When the earth-fault current exceeds the set start value of high-set stage $I_{0>>}$, the earth-fault unit will start to deliver a start signal after a ~ 60 ms' start time. When the set operate time elapses, the earth-fault unit will deliver a trip signal.

It is possible to block the start and the tripping of an earth-fault stage by applying an external binary input signal to the relay.

The inverse-time function of stage $I_{0>}$ can be set to be inhibited when stage $I_{0>>}$ starts with a switch of switchgroup SGF2. In this case the operate time will be determined by stage $I_{0>>}$.

The high-set stage can be set out of operation. This state will be indicated by dashes on the LCD and by "999" when the set start value is read via serial communication.

The set start value of stage $I_{0>>}$ can be automatically doubled in a start situation, e.g. when the object to be protected is connected to a distribution network. Thus a set start value below the connection inrush current level can be selected for stage $I_{0>>}$. A start situation is defined as a situation where the earth-fault current rises from a value below $12\% \times I_{0>}$ to a value above $150\% \times I_{0>}$ in less than 60 ms. The start situation ends when the current falls below $125\% \times I_{0>}$.

5.1.4.3.

Zero-sequence voltage unit

When the zero-sequence voltage exceeds the set start value of low-set stage $U_{0b>}$, the voltage unit will start to deliver a start signal after a ~ 70 ms' start time. When the set operate time at definite-time characteristic elapses, the voltage unit will deliver a trip signal.

The two current stages, $I_{0>}$ and $I_{0>>}$, can be replaced by two additional voltage stages, low-set stage $U_{0>}$ and high-set stage $U_{0>>}$, to create a three-stage zero-sequence voltage module. All three voltage stages measure the same voltage but can have separate settings both regarding sensitivity and operate time. The signalling and trip relays can also be selected separately for all three stages.

When the zero-sequence voltage exceeds the set start value of low-set stage $U_{0>}$, the voltage unit will start to deliver a start signal after a ~ 70 ms' start time. When the set operate time at definite-time characteristic elapses, the voltage unit will deliver a trip signal.

When the zero-sequence voltage exceeds the set start value of high-set stage $U_{0>>}$, the voltage unit will start to deliver a start signal after a ~ 60 ms' start time. When the set operate time elapses, the voltage unit will deliver a trip signal.

It is possible to block the start and the tripping of a voltage stage by applying an external binary input signal to the relay.

High-set stage $U_{0>>}$ can be set out of operation. This state will be indicated by dashes on the LCD and by "999" when the set start value is read via serial communication.

5.1.4.4.

Protection against intermittent earth-faults

An intermittent earth-fault typically occurs in an insulated cable where the insulation has a crack and water leaks into the cable. The earth-fault dries up the crack in the cable, extinguishing the fault, but reappears after a short time as water leaks back through the crack. The process repeats, resulting in a succession of fault current pulses.

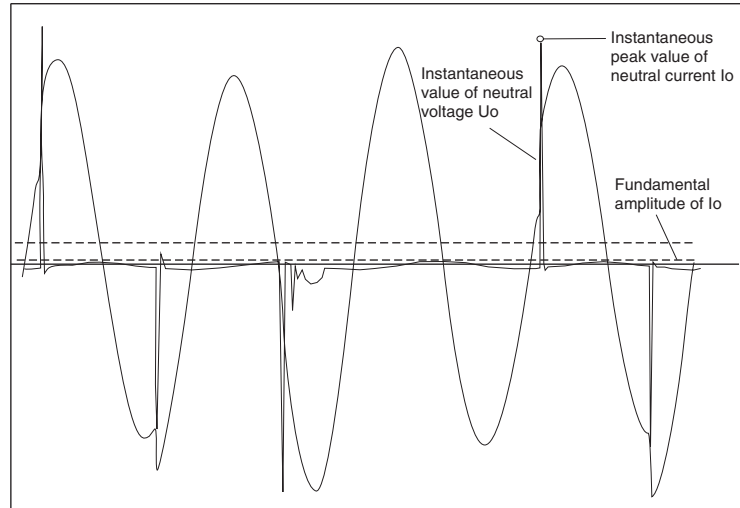

A0501429

Fig. 5.1.4.4.-1 Intermittent fault

When the resetting time of the overcurrent unit is shorter than the interval between the fault current pulses, the relay will be continually reset and not able to trip. A resetting time longer than the start time, but short enough not to interfere with normal operation of the protection and control system, will help to eliminate some less common health and safety problems.

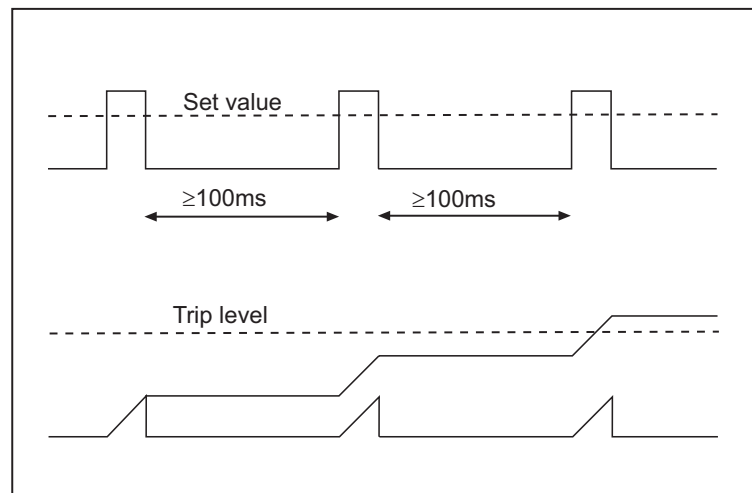

A0501430

Fig. 5.1.4.4.-2 Selectable resetting time

The resetting time can be set to 80, 100, 500 or 1000 ms in SGF5. When the resetting time is set to 100 ms or above, earth-fault stage $I_{0>}$ will operate as an intermittent earth-fault stage.



If the CBFP function is in use and a resetting time longer than 80 ms is selected, a CBFP operate time longer than the resetting time is recommended.

5.1.4.5.

Time/current characteristics

The low-set earth-fault current stage can be given either a definite-time or an inverse definite minimum time (IDMT) characteristic whereas the high-set earth-fault current stage and the voltage stage(s) feature the definite-time characteristic alone. The settings of switches SGF4/1...6 determine the operation mode of the stage. Refer to section Settings for additional information.

At IDMT characteristic, the operate time of the stage is dependent on the current value: the higher the current value, the shorter the operate time. Six time/current curve groups are available, of which four comply with the IEC 60255 standard: the normal inverse, very inverse, extremely inverse and long-time inverse. The two additional inverse-time curve groups, referred to as RI and RD, are special curve groups according to ABB praxis.

Characteristics according to the IEC 60255 standard

The relay module incorporates four internationally standardized time/current curve groups called extremely inverse, very inverse, normal inverse and long-time inverse. The relationship between time and current is in accordance with the IEC 60255-3 standard and can be expressed as follows:

$$t[s] = \frac{k \times \beta}{\left(\frac{I_0}{I_{0>}}\right)^\alpha - 1}$$

where

t = operate time

k = time multiplier

I_0 = earth-fault current value

$I_{0>}$ = set start value

Table 5.1.4.5-1 The values of constants α and β

Time/current curve group	α	β
Normal inverse	0.02	0.14
Very inverse	1.0	13.5
Extremely inverse	2.0	80.0
Long-time inverse	1.0	120

According to the standard, the normal current range is 2...20 times the setting value at normal inverse, very inverse or extremely inverse characteristic. The relay is to start before the current exceeds the setting value by 1.3 times. At long-time inverse characteristic, the normal current range is specified to be 2...7 times the setting value, and the relay is to start before the current exceeds the setting value by 1.1 times.

Table 5.1.4.5-2 The operate time tolerances specified by the standard

$I_0/I_{0>}$	Normal	Very	Extremely	Long time
2	2,22E	2,34E	2,44E	2,34E
5	1,13E	1,26E	1,48E	1,26E
7	-	-	-	1,00E
10	1,01E	1,01E	1,02E	-
20	1,00E	1,00E	1,00E	-

E = accuracy in percent; - = not specified

Within the normal current range the inverse-time stage fulfils the tolerance requirements of class 5 at all degrees of inversivity.

The time/current characteristics according to the IEC and BS standards are illustrated in Fig. 5.1.4.5.-1...Fig. 5.1.4.5.-4.



If the ratio between the current and the set start value is higher than 20, the operate time will be the same as when the ratio is 20.

RI-type characteristic

The RI-type characteristic is a special characteristic which is principally used for obtaining time grading with mechanical relays. The characteristic can be expressed mathematically as follows:

$$t[s] = \frac{k}{0.339 - 0.236 \times \frac{I_{0>}}{I_0}}$$

where

t = operate time

k = time multiplier

I_0 = earth-fault current value

$I_{0>}$ = set start value

The RI-type characteristic is illustrated in Fig. 5.1.4.5.-5.

RD-type characteristic

The RD-type characteristic is a special characteristic which is principally used in earth-fault protection and which requires a high degree of selectivity even at high resistance faults. The protection can operate in a selective way even if it is not directional. Mathematically the time/current characteristic can be expressed as follows:

$$t[s] = 5.8 - 1.35 \times \log_e \left(\frac{I_0}{k \times I_{0>}} \right)$$

where

t = operate time

k = time multiplier

I_0 = earth-fault value

$I_{0>}$ = set start value

The RD-type characteristic is illustrated in Fig. 5.1.4.5.-6.

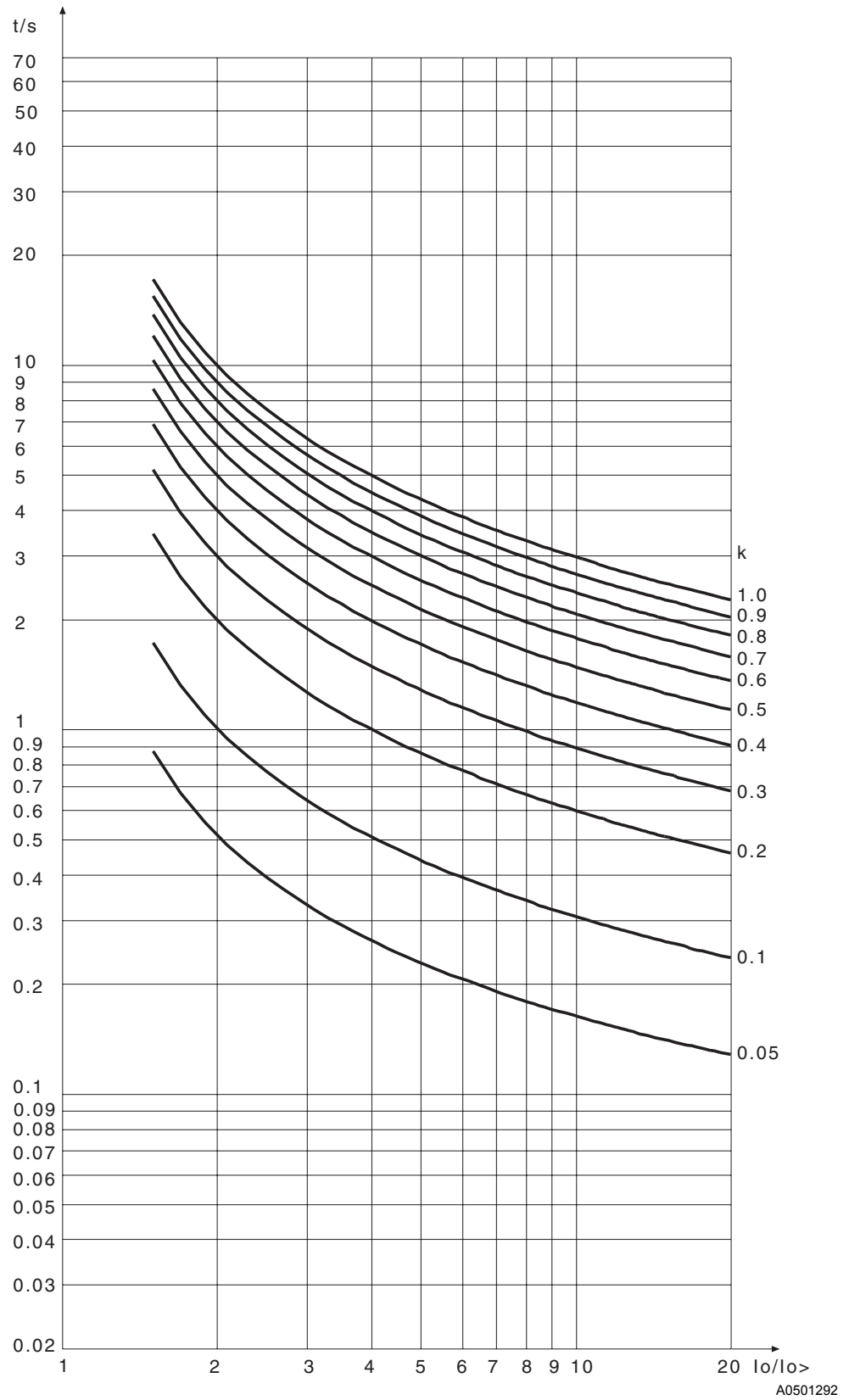

Fig. 5.1.4.5.-1 Normal inverse-time characteristic

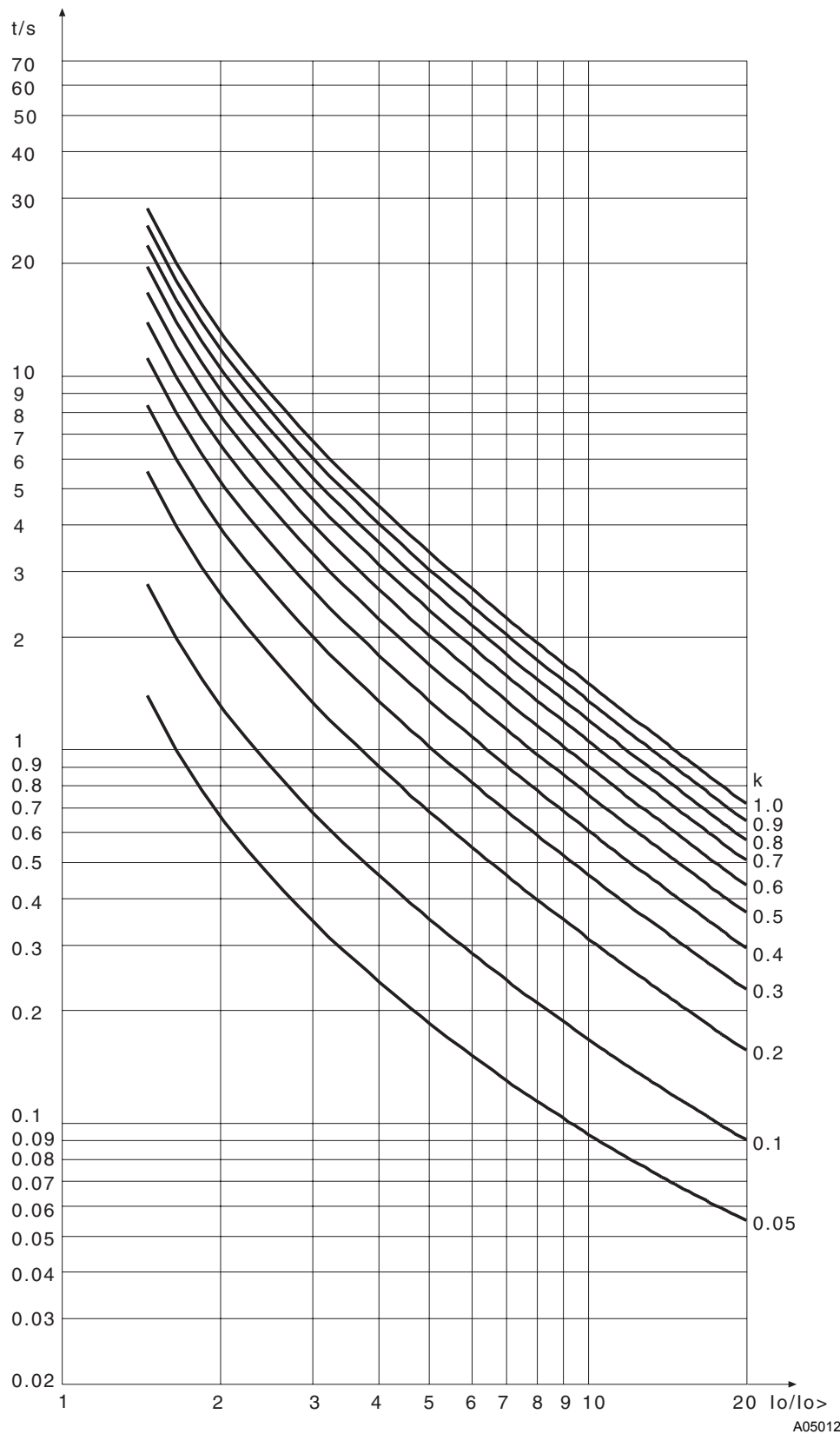

Fig. 5.1.4.5.-2 Very inverse-time characteristic

A0501293

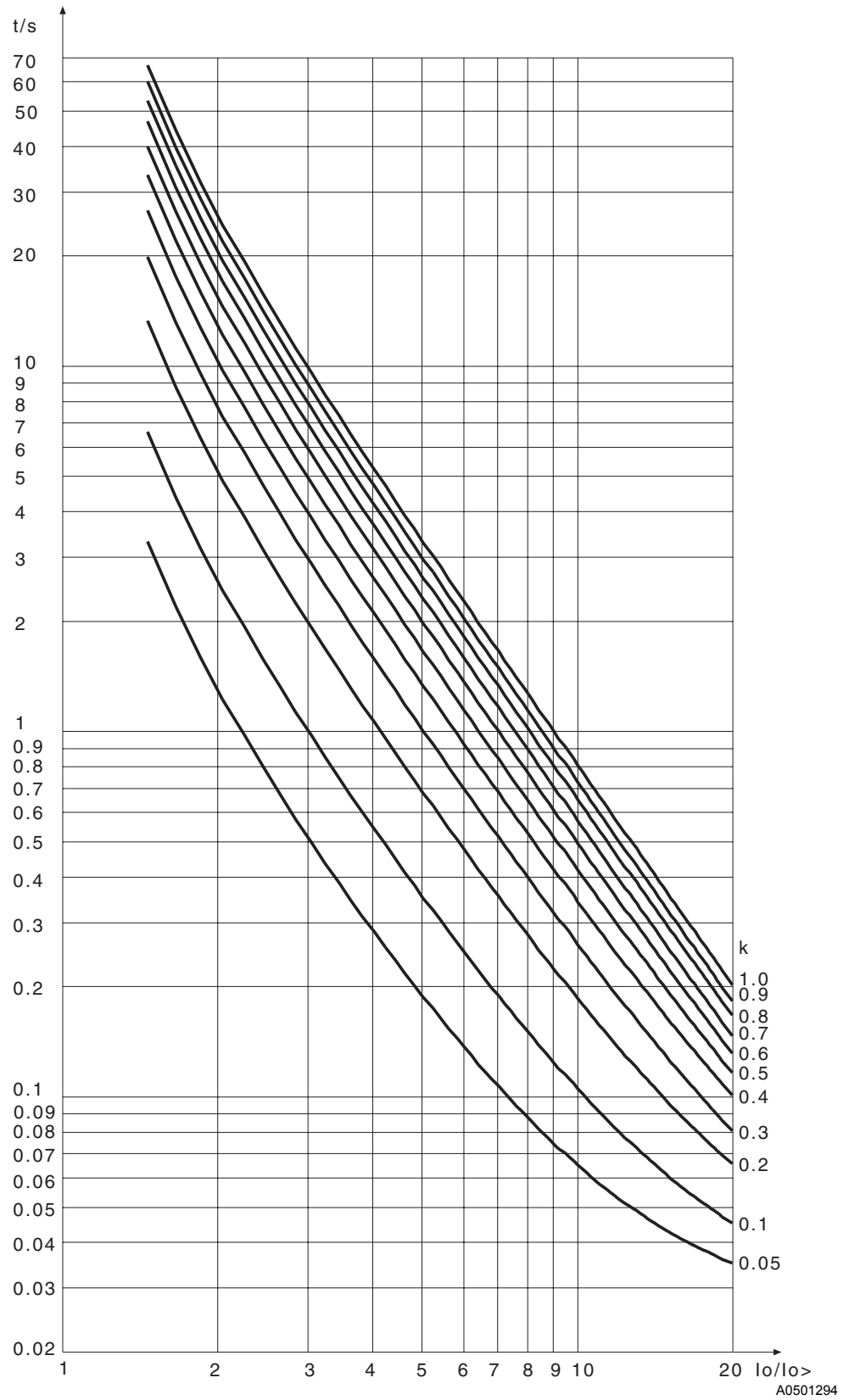

Fig. 5.1.4.5.-3 Extremely inverse-time characteristic

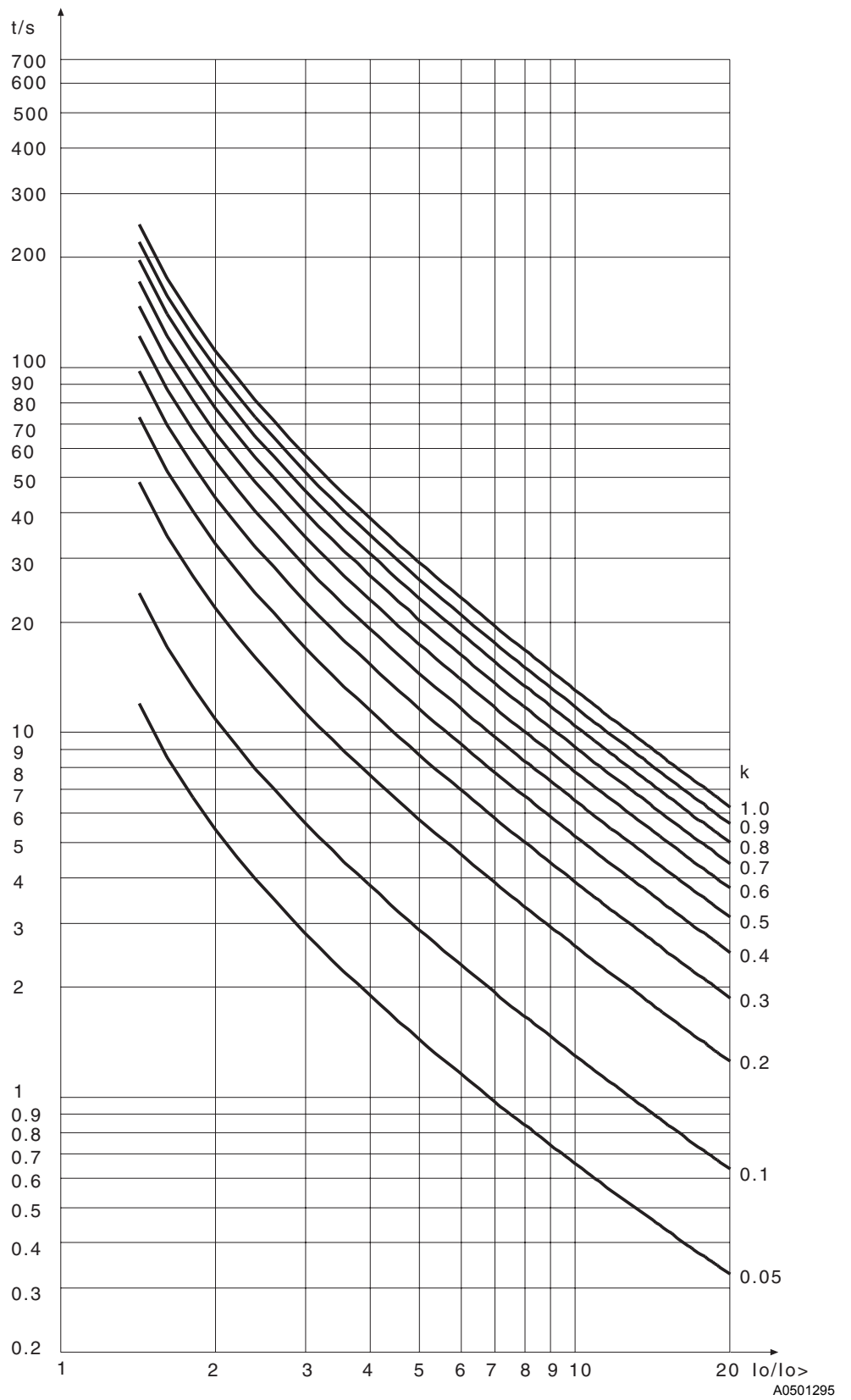

Fig. 5.1.4.5.-4 Long-time inverse-time characteristic

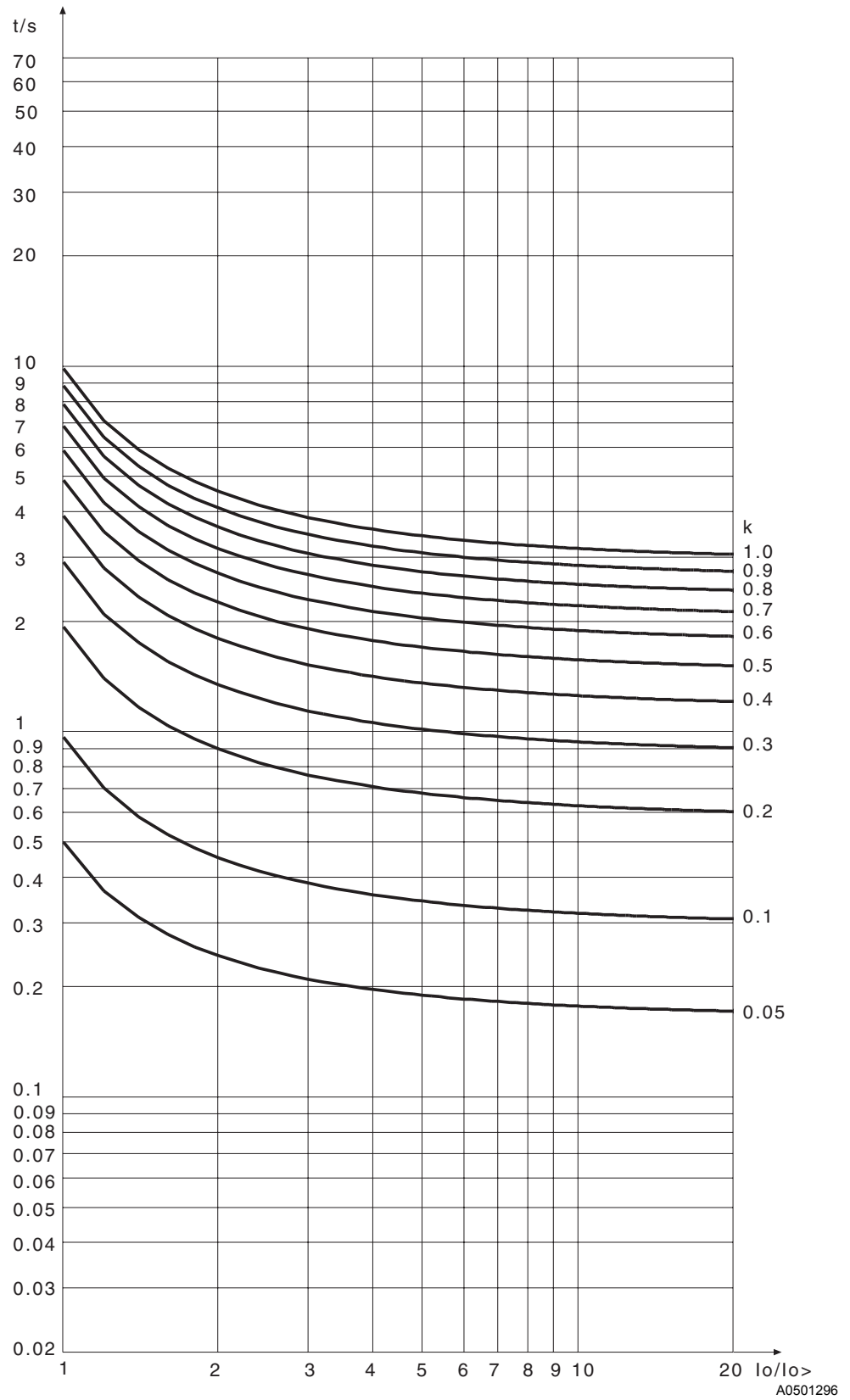

Fig. 5.1.4.5.-5 RI-type inverse-time characteristic

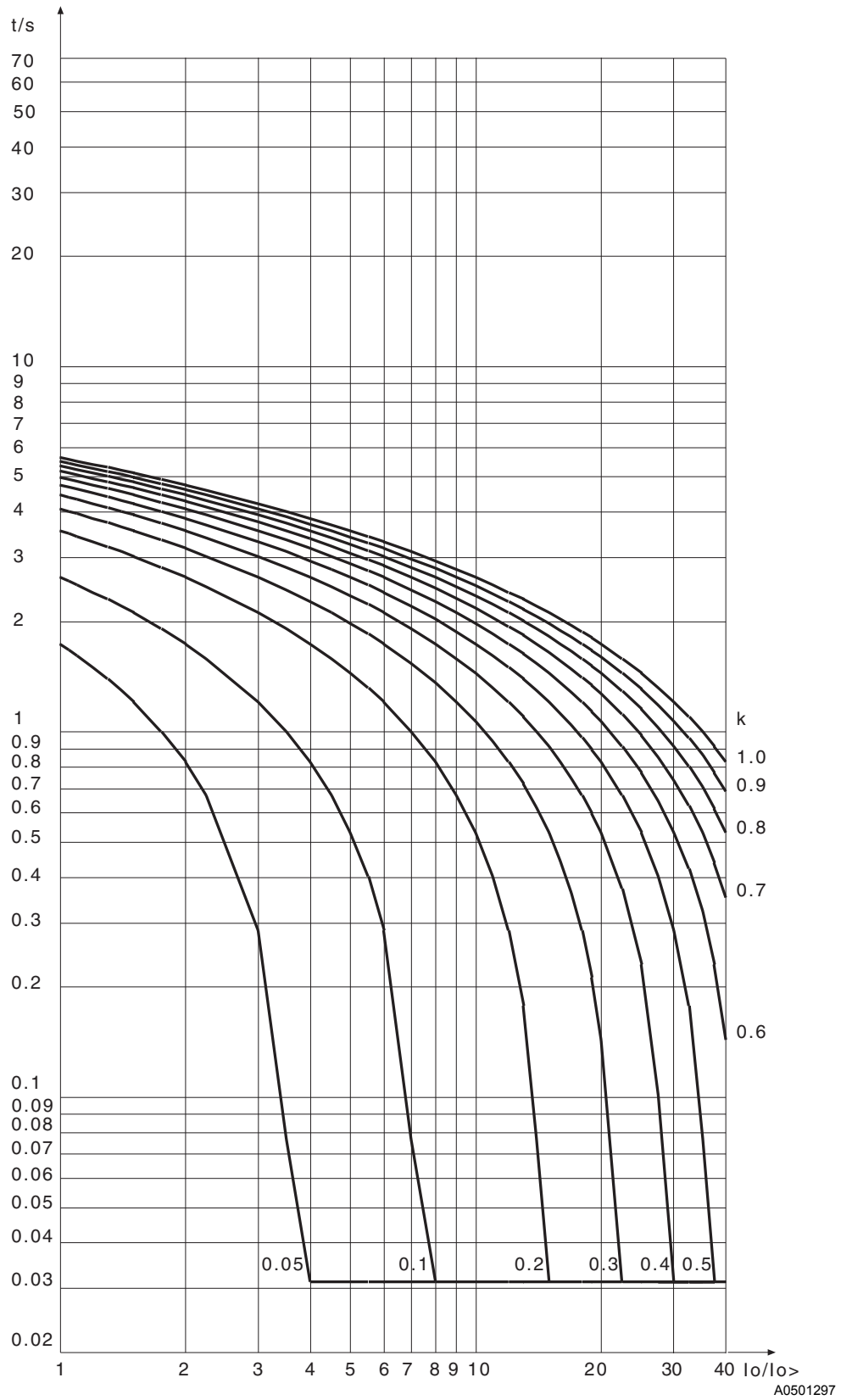

Fig. 5.1.4.5.-6 RD-type inverse-time characteristics

5.1.4.6.

Settings

There are two alternative setting groups available, setting groups 1 and 2. Either of these setting groups can be used as the actual settings, one at a time. Both groups have their related registers. By switching between the setting groups a whole group of settings can be changed at the same time. This can be done in any of the following ways:

Group configuration:

- via the HMI
- entering parameter V150 via serial communication

Group selection:

- switching between Group1 and Group2 is accomplished by means of the external binary input

The setting values can be altered via the HMI or with a personal computer provided with the Relay Setting Tool.

Before the relay is connected to a system it must be assured that the relay has been given the correct settings. If there is any doubt, the setting values should be read with the relay trip circuits disconnected or tested with current injection, refer to section Check lists for additional information.

Table 5.1.4.6-1 Setting values

Setting	Description	Setting range	Default setting
$U_{0b}>/U_n$	Set start value of stage $U_{0b}>$ as a percentage of the energizing input used • definite time	2.0...80.0% x U_n	2.0% x U_n
$t_{b}>$	Operate time of stage $U_{0b}>$ in seconds at definite-time characteristic	0.10...300 s	0.10 s
$I_{0}>/I_n$	Set start value of stage $I_{0}>$ as a percentage of the energizing input used • definite time • inverse time	1.0...100% x I_n 1.0...40.0% x I_n	1.0% x I_n 1.0% x I_n
$U_{0}>/U_n$	Set start value of stage $U_{0}>$ as a percentage of the energizing input used • definite time	2.0...80.0% x U_n	2.0% x U_n
$t_{0}>$	Operate time of stage $I_{0}>$ or $U_{0}>$ in seconds at definite-time characteristic	0.10...300 s	0.10 s
$k>$	Time multiplier k of stage $I_{0}>$ at IDMT characteristic	0.05...1.00	0.05
$I_{0}>>/I_n$	Set start value of stage $I_{0}>>$ as a percentage of the energizing input used • definite time	5.0...400% x $I_n^{(2)}$	5.0% x I_n
$U_{0}>>/U_n$	Set start value of stage $U_{0}>>$ as a percentage of the energizing input used • definite time	2.0...80.0% x $U_n^{(2)}$	2.0% x U_n

Table 5.1.4.6-1 Setting values (Continued)

Setting	Description	Setting range	Default setting
$t_{0>>}$	Operate time of stage $I_{0>>}$ or $U_{0>>}$ in seconds at definite-time characteristic	0.10...300 s	0.10 s
φ_a	Additional angle of stages $I_{0>}$ and $I_{0>>}$ with the basic angle characteristic	0...90°	0°
φ_b	Basic angle of stages $I_{0>}$ and $I_{0>>}$.	-90...0°	-90°
φ_c	Angle correction of stages $I_{0>}$ and $I_{0>>}$ with the I_φ characteristic	2...7°	2°
CBFP	Circuit-breaker failure protection	0.10...1.00 s	0.10 s

- 1) At IDMT characteristic, the REJ 527 allows settings above 40% x I_n for stage I_0 , but regards any setting >40% x I_n as equal to 40% x I_n .
- 2) The stage can be set out of operation in SGF. This state will be indicated by dashes on the LCD and by "999" when parameters are read via the SPA bus.

Switchgroups and parameter masks

The settings can be altered and the operation characteristics of the relay in various applications selected in the SG_ selector switchgroups. The switchgroups are software based and thus not physical switches to be found in the hardware of the relay. The switches can be set one by one.

A checksum is used for verifying that the switches have been properly set. The figure below shows an example of manual checksum calculation.

Switch No	Position		Weighting factor		Value
1	1	x	1	=	1
2	0	x	2	=	0
3	1	x	4	=	4
4	0	x	8	=	0
5	1	x	16	=	16
6	0	x	32	=	0
7	1	x	64	=	64
8	0	x	128	=	0
Checksum			SG_Σ	=	85

Fig. 5.1.4.6.-1 An example of calculating the checksum of a SG_ selector switchgroup

When the checksum, calculated according to the example above, equals the checksum of the relay, the switches in the switchgroup have been properly set.

The factory default settings of the switches and the corresponding checksums are presented in the tables below.

SGF1...SGF5

Switchgroups SGF1...SGF5 are used for configuring the desired function as follows.

Table 5.1.4.6-2 SGF1

Switch	Function	Default setting
SGF1/1	Selection of the latching feature for power output PO1	0
SGF1/2	Selection of the latching feature for power output PO2 <ul style="list-style-type: none"> • When the switch is in position 0 and the measuring signal which caused the trip falls below the set start value, the output contact will return to its initial state. • When the switch is in position 1, the output contact will remain active although the measuring signal which caused the trip falls below the set start value. A latched output contact can be unlatched either via the HMI, the external binary input or the serial bus.	0
SGF1/3	Minimum pulse length for signal outputs SO1 and SO2 <ul style="list-style-type: none"> • 0=80 ms • 1=40 ms 	0
SGF1/4	Minimum pulse length for power outputs PO1 and PO2 <ul style="list-style-type: none"> • 0=80 ms • 1=40 ms Note! The latching function of PO1 and PO2 will overrun this function.	0
SGF1/5	CBFP <ul style="list-style-type: none"> • When the switch is in position 0, the CBFP is not in use. • When the switch is in position 1, the signal to output PO1 will start a timer which will generate a delayed signal to output PO2, provided that the fault is not cleared before the CBFP operate time has elapsed. 	0
SGF1/6	Not in use	0
SGF1/7	Not in use	0
SGF1/8	Not in use	0
Σ SGF1		0

Table 5.1.4.6-3 SGF2

Switch	Function	Default setting
SGF2/1	Automatic doubling of the set start value of stage I _{>>} <ul style="list-style-type: none"> When the switch is in position 1, the set start value of the stage will automatically be doubled at high inrush situations. 	0
SGF2/2	Inverse-time operation of stage I _{0>} inhibited by the start of stage I _{0>>} <ul style="list-style-type: none"> When the switch is in position 1, inverse-time operation is inhibited. 	0
SGF2/3	Inhibition of stage I _{0>>} or U _{0>>} <ul style="list-style-type: none"> When the switch is in position 1, the stage is inhibited 	0
SGF2/4	The operation mode of the start indication of stage I _{0>} or U _{0>} <ul style="list-style-type: none"> 0 = the start indication will automatically be cleared once the fault has disappeared 1 = latching. The start indication will remain active although the fault has disappeared. 	0
SGF2/5	The operation mode of the start indication of stage I _{0>>} or U _{0>>} <ul style="list-style-type: none"> 0 = the start indication will automatically be cleared once the fault has disappeared 1 = latching. The start indication will remain active although the fault has disappeared. 	0
SGF2/6	The operation mode of the start indication of stage U _{0b>} <ul style="list-style-type: none"> When the switch is in position 0, the start indication will automatically be cleared once the fault has disappeared. 	0
SGF2/7	Selection of the earth-fault current or the zero-sequence voltage unit <ul style="list-style-type: none"> 0 = the unit operates with two I₀-stages and a voltage deblocking facility 1 = the unit operates as a three-stage zero-sequence voltage unit 	0
SGF2/8	Selection of U ₀ deblocking for the directional earth-fault protection <ul style="list-style-type: none"> 0 = U₀ deblocking is in use. 1 = U₀ deblocking is not in use. 	0
Σ SGF2		0

Table 5.1.4.6-4 SGF3

Switch	Function	Default setting
SGF3/1	Selection of directional or non-directional operation for stage $I_0>$ • 0 = directional • 1 = non-directional	0
SGF3/2	Selection of operation for stage $I_0>$ • 0 = forward direction • 1 = reverse direction	0
SGF3/3	Selection of directional or non-directional operation for stage $I_0>>$ • 0 = directional • 1 = non-directional	0
SGF3/4	Selection of operation for stage $I_0>>$ • 0 = forward direction • 1 = reverse direction	0
SGF3/5	Selection of operation criteria for the directional earth-fault protection • 0 = I_0 with the basic angle • 1 = operation criteria $I_0\sin(\varphi)$ or $I_0\cos(\varphi)$	0
SGF3/6	Selection of operation areas for the directional earth-fault protection • 0 = the operation sector is $\pm 80^\circ$ • 1 = the operation sector is $\pm 88^\circ$	0
SGF3/7	Selection of the $I_0\sin(\varphi)$ or $I_0\cos(\varphi)$ characteristic • 0 = $I_0\sin(\varphi)$ characteristic • 1 = $I_0\cos(\varphi)$ characteristic	0
SGF3/8	Selection of phase angle presentation ¹⁾ • 0 = phase angle (φ) between φ_b and I_0 • 1 = phase angle (φ) between I_0 and U_0	0
Σ SGF3		0

¹⁾ The directional earth-fault stages are not affected.

Table 5.1.4.6-5 SGF4: $I_0>$ characteristics

SGF4/1	SGF4/2	SGF4/3	SGF4/4	SGF4/5	SGF4/6	SGF4/7	SGF4/8	Operation
0	0	0	0	0	0	-	-	Definite time ¹⁾
1	0	0	0	0	0	-	-	Extremely inverse
0	1	0	0	0	0	-	-	Very inverse
0	0	1	0	0	0	-	-	Normal inverse
0	0	0	1	0	0	-	-	Long-time inverse
0	0	0	0	1	0	-	-	RI
0	0	0	0	0	1	-	-	RD

¹⁾ Default setting



Only one type of characteristic can be selected at a time. If more than one switch is selected, the characteristic with the lowest weighting factor of the selected switches will be activated.

Table 5.1.4.6-6 SGF5: Resetting time of stage $I_0>/U_0>$

SGF5/1	SGF5/2	SGF5/3	SGF5/4	SGF5/5	SGF5/6	SGF5/7	SGF5/8	Operation
0	0	0	-	-	-	-	-	80 ms ¹⁾
1	0	0	-	-	-	-	-	100 ms
0	1	0	-	-	-	-	-	500 ms
0	0	1	-	-	-	-	-	1000 ms

¹⁾ Default setting

If the resetting time ≥ 100 ms, stage $I_0>$ will operate as an intermittent earth-fault stage.



Only one type of characteristic can be selected at a time. If more than one switch is selected, the characteristic with the lowest weighting factor of the selected switches will be activated.

SGB1

Table 5.1.4.6-7 SGB1 Resetting/blocking with BI

Switch	Function	Default setting
SGB1/1	<ul style="list-style-type: none"> • 0 = indications are not cleared by the binary input signal • 1 = indications are cleared by the binary input signal 	0
SGB1/2	<ul style="list-style-type: none"> • 0 = indications are not cleared and latched output contacts are not unlatched by the binary input signal • 1 = indications are cleared and latched output contacts are unlatched by the binary input signal 	0
SGB1/3	<ul style="list-style-type: none"> • 0 = indications and memorized values are not cleared and latched output contacts are not unlatched by the binary input signal • 1 = indications and memorized values are cleared and latched output contacts are unlatched by the binary input signal 	0
SGB1/4	Switching between setting groups 1 and 2 using the external binary input <ul style="list-style-type: none"> • 0 = the setting group cannot be changed using the external binary input • 1 = the currently used setting group is determined by the binary input. When the binary input is energized, setting group 2 will be activated. Note! When SGB1/4 is set to 1, it is important that the switch has the same setting in both setting groups.	0
SGB1/5	Blocking of stage $t_b>$ by the binary input signal	0
SGB1/6	Blocking of stage $t_0>$ by the binary input signal	0
SGB1/7	Blocking of stage $t_0>>$ by the binary input signal <ul style="list-style-type: none"> • When SGB1/5...7 = 0, tripping of the stage will not be blocked by the external binary input signal. • When SGB1/5...7 = 1, tripping of the stage will be blocked by the external binary input signal. 	0
SGB1/8	Set the basic angle $0^\circ/-90^\circ$ or $\cos(\varphi)/\sin(\varphi)$ using the binary input <ul style="list-style-type: none"> • 0 = the binary input signal does not affect the basic angle • 1 = the basic angle is -90° or $\sin(\varphi)$ when the external binary input signal is not energized. When the input is energized, the basic angle is 0° or $\cos(\varphi)$. 	0
Σ SGB1		0

SGR1...SGR6

The start and trip signals from the protection stages are connected to the output contacts with the switches of switchgroups SGR1...SGR6.

The matrix below can be of help when making the desired selections. The start and trip signals from the different protection stages are combined with the output contacts by encircling the desired intersection point. Each intersection point is marked with a switch number, and the corresponding weighting factor of the switch is shown on the bottom line of the matrix. The switchgroup checksum is obtained by horizontally adding the weighting factors of all the selected switches of the switchgroup.

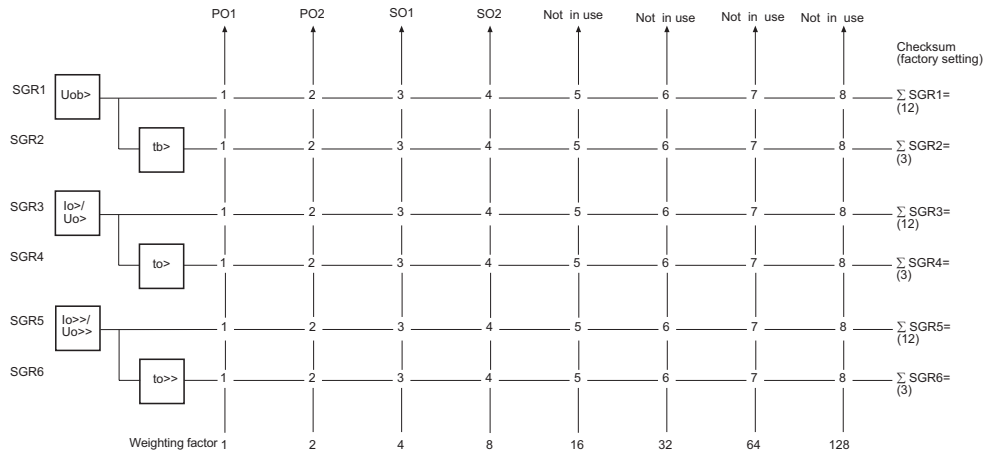

A0501431

Fig. 5.1.4.6.-2 Output signal matrix of the directional earth-fault relay

Table 5.1.4.6-8 SGR1...SGR6

Switch	Function	Default
SGR1/1...4	U _{0b} > signal to output contacts PO1, PO2, SO1 and SO2	12
SGR2/1...4	t _b > signal to output contacts PO1, PO2, SO1 and SO2	3
SGR3/1...4	I ₀ >/U ₀ > signal to output contacts PO1, PO2, SO1 and SO2	12
SGR4/1...4	t ₀ > signal to output contacts PO1, PO2, SO1 and SO2	3
SGR5/1...4	I ₀ >>/U ₀ >> signal to output contacts PO1, PO2, SO1 and SO2	12
SGR6/1...4	t ₀ >> signal to output contacts PO1, PO2, SO1 and SO2	3

New trip indication timer

The new trip indication timer can be configured to allow a second trip indication on the LCD. When several protection stages trip, the first trip indication will be displayed until the time, as specified by the “NEW TRIP IND.” setting value, has expired. After this, a new trip indication can displace the old one. The basic protection functions are not affected by the “NEW TRIP IND.” setting.

Table 5.1.4.6-9 New trip indication timer

Setting	Description	Setting range	Default setting
New trip indication	New trip indication timer in minutes No new trip indication allowed until the previous one has been manually cleared	0...998 999	60

Non-volatile memory settings

The table below presents data which can be configured to be stored in the non-volatile memory. All of the functions mentioned below can be selected separately with switches 1...5 in “MEMORY SETTINGS”.

Table 5.1.4.6-10 Memory settings

Switch	Function	Default setting
1	<ul style="list-style-type: none"> • 0 = alarm indication messages and LEDs will be cleared • 1 = alarm indication messages and LEDs will be retained 	1
2	<ul style="list-style-type: none"> • 1 = information on the "NUMBER OF STARTS" of the protection stages will be retained 	1
3	<ul style="list-style-type: none"> • 1 = disturbance recorder data will be retained 	1
4	<ul style="list-style-type: none"> • 1 = event codes will be retained 	1
5	<ul style="list-style-type: none"> • 1 = recorded data will be retained 	1
6	Not in use	0
7	Not in use	0
8	Not in use	0
checksum		31

5.1.4.7.**Technical data on protection functions****Table 5.1.4.7-1 Stage $U_{0b}>$**

Feature	Stage $U_{0b}>$
Set start value	
<ul style="list-style-type: none"> • at definite-time characteristic 	$2.0...80.0\% \times U_n$
Start time, typical	70 ms
Time/current characteristic	
<ul style="list-style-type: none"> • definite time operate time $t_{0b}>$ 	0.10...300 s
Resetting time, typical	60 ms
Drop-off/pick-up ratio, typical	0.96
Operate time accuracy at definite-time characteristic	$\pm 2\%$ of the set start value or ± 25 ms
Operation accuracy	
<ul style="list-style-type: none"> • $2.0...80.0\% \times U_n$ 	$\pm 3\%$ of the set start value $+0.05\% \times U_n$

Table 5.1.4.7-2 Stages $I_{0>}$ or $U_{0>}$ and $I_{0>>}$ or $U_{0>>}$

Feature	Stage $I_{0>}^{1)}$ or $U_{0>}$	Stage $I_{0>>}$ or $U_{0>>}$
Operation direction of stages $I_{0>}$ and $I_{0>>}$	forward or reverse	forward or reverse
Operation mode of stages $I_{0>}$ and $I_{0>>}$	directional or non-directional	directional or non-directional
Set start value		
<ul style="list-style-type: none"> • at definite-time characteristic 	$1.0...100\% \times I_n$	$5.0...400\% \times I_n^{3)}$
<ul style="list-style-type: none"> • at IDMT characteristic¹⁾ 	$1.0...40.0\% \times I_n^{2)}$	
Set start value		
<ul style="list-style-type: none"> • at definite-time characteristic 	$2.0...80.0\% \times U_n$	$2.0...80.0\% \times U_n$

Table 5.1.4.7-2 Stages $I_{0>}$ or $U_{0>}$ and $I_{0>>}$ or $U_{0>>}$ (Continued)

Feature	Stage $I_{0>}^{1)}$ or $U_{0>}$	Stage $I_{0>>}$ or $U_{0>>}$
Start time, typical	70 ms	60 ms
Time/current characteristics		
• definite time operate times $t_{0>}$ and $t_{0>>}$	0.10...300 s	0.10...300 s
• IDMT for stage $I_{0>}$ as per IEC 60255-3	Extremely inverse Very inverse Normal inverse Long-time inverse	
• special type of inverse-time characteristic	RI-type inverse RD-type inverse	
time multiplier k of stage $I_{0>}$	0.05...1.00	
Selectable resetting time	80, 100, 500 or 1000 ms	100 ms
Drop-off/pick-up ratio, typical	0.96	0.96
Operate time accuracy at definite-time characteristic	$\pm 2\%$ of the set start value or ± 25 ms	$\pm 2\%$ of the set start value or ± 25 ms
Accuracy class index E at IDMT characteristic	5 ± 25 ms	
Operation accuracy		
• $1.0...100.0\% \times I_n$	$\pm 3\%$ of the set start value $+0.05\% \times I_n$	$\pm 3\%$ of the set start value $+0.05\% \times I_n$
• $2.0...80.0\% \times U_n$	$\pm 3\%$ of the set start value $+0.05\% \times U_n$	$\pm 3\%$ of the set start value $+0.05\% \times U_n$

¹⁾ The start and the tripping of the low-set earth-fault current stage can be blocked by the starting of the high-set stage, provided that this function has been selected in SGF. If set in SGF, the operate time will be determined by the set operate time of the high-set stage at heavy fault currents. In order to obtain a trip signal, the high-set stage must be routed to PO1 or PO2.

²⁾ At IDMT characteristic, the relay allows settings above $40.0\% \times I_n$ for stage $I_{0>}$, but regards any setting $> 40.0\% \times I_n$ as equal to $40.0\% \times I_n$.

³⁾ The stage can be set out of operation in SGF. This state will be indicated by dashes on the LCD and by "999" when parameters are read via the SPA bus.

Table 5.1.4.7-3 Directional element

Feature	Setting range
Setting range of the basic angle φ_b	$-90...0^\circ$
Operation sector	$\varphi_b \pm 80^\circ$ or $\pm 88^\circ$ with the extended sector $\varphi_a 0...90^\circ$
Operation sector accuracy	$\pm 5^\circ$
Threshold current for angle measurement	
• pick-up/drop-off	0.50/0.30%
Threshold voltage for angle measurement	
• pick-up/drop-off	0.48/0.36%

5.1.5.

Indicator LEDs and alarm indication messages

The operation of the REJ 527 can be monitored by means of three indicators on the front panel of the relay: a green READY indicator LED, a yellow START indicator LED and a red TRIP indicator LED (refer to the Operator's Manual for a more thorough presentation).

In addition, in case of an alarm from a protection stage, a text message will appear on the LCD.

The messages on the LCD have a certain priority order. If different types of indications are activated simultaneously, the message with the highest priority will appear on the LCD.

The priority order of the messages:

1. CBFP
2. TRIP
3. START

5.1.6. Commissioning test

The function test is used for testing the configuration as well as the connections to and from the relay. By selecting this test the ten internal signals from the protection stages and the IRF function can be activated and tested one by one. Provided that the internal signals from the protection stages have been set to be routed to the output contacts (PO1, PO2, SO1 and SO2) with the switches of SGR1...6, the output contacts will be activated and the corresponding event codes generated when the test is run. The test will not generate protection function event codes. Additionally, if the CBFP function is in use and PO1 is activated, PO2 will be activated, too.

The state of the binary input can be monitored by selecting the binary input test, and the LEDs can be turned on by selecting the LED test. Refer to the Operator's Manual for more detailed instructions on how to perform the tests.

5.1.7. Disturbance recorder

5.1.7.1. Function

The REJ 527 features an integrated disturbance recorder for recording monitored quantities. The recorder continuously captures the curve forms of the current and voltage as well as the status of both the internal signals and the external binary input signal and stores these in the memory.

Triggering of the recorder will generate an event code. After the recorder has been triggered, it will continue to record data for a pre-defined post-triggering time. An asterisk will be shown on the LCD on completion of the recording. The status of the recording can also be viewed using a SPA parameter.

As soon as the recorder has been triggered and the recording has finished, the recording can be uploaded and analyzed by means of a PC provided with a special program.

5.1.7.2. Disturbance recorder data

One recording contains data from the two analogue channels and the seven digital channels for a preselected time. The analogue channels, whose data is stored either as RMS curves or momentary measured values, are the currents measured by the relay. The digital channels, referred to as digital signals, are the start and trip signals from the protection stages and the external binary input signal linked to the relay.

The recording length varies according to the selected sampling frequency. The RMS curve is recorded by selecting the sampling frequency to be the same as the nominal frequency of the relay. The sampling frequency is selected with parameter M15; see the table below for details.

Table 5.1.7.2-1 Sampling frequency

Nominal frequency Hz	Sampling frequency Hz	Cycles
50	800	60
	400	120
	50 ¹⁾	960
60	960	60
	480	120
	60 ¹⁾	960

¹⁾ RMS curve.

Recording length:

$$[s] = \frac{Cycles}{Nominal\ frequency[Hz]}$$

Changing the setting values of parameters M15 is allowed only when the recorder has not been triggered.

The post-triggering recording length defines the time during which the recorder continues to store data after it has been triggered. The length can be changed with parameter V240. If the post-triggering recording length has been defined to be the same as the total recording length, no data stored prior to the triggering will be retained in the memory. By the time the post-triggering recording finishes, a complete recording will have been created.

Triggering of the recorder immediately after it has been cleared or the auxiliary voltage connected may result in a shortened total recording length. Disconnection of the auxiliary voltage after the recorder has been triggered but before the recording has finished, on the other hand, may result in a shortened post-triggering recording length. This, however, will not affect the total recording length.

At a power reset, triggered recorder data will be retained in the memory provided that it has been defined non-volatile.

5.1.7.3.

Control and indication of disturbance recorder status

It is possible to control and monitor the recording status of the disturbance recorder by writing to and reading parameters M1, M2 and V246. Reading parameter V246 will return either the value 0 or 1, indicating whether the recorder has not been triggered or triggered and ready to be uploaded. Event code E31 will be generated the moment the disturbance recorder has been triggered. If the recorder is ready to be uploaded, this will also be indicated by an asterisk shown in the lower right-hand corner of the LCD when it is in the idle mode.

Writing the value 1 to parameter M2 will clear the recorder memory, restart the storing of new data and enable the triggering of the recorder. Recorder data can be cleared by performing a master reset. Writing the value 2 to parameter V246 will restart the unloading process by setting the time stamp and the first data ready to be read.

5.1.7.4. Triggering

The user can select the start or trip signal from any protection stage and/or the external binary input signal to trigger the disturbance recorder, either on the rising or falling edge of the signal(s). Triggering on the rising edge means that the post-triggering recording sequence will start when the signal is activated. Correspondingly, triggering on the falling edge means that the post-triggering recording sequence will start when the active signal is reset. The trigger signal(s) and the edge are selected with parameters V241...V244; see tables 5.1.9.4-5 and 5.1.9.4-6. The recorder can also be triggered manually using parameter M1.

Triggering of the disturbance recorder is only possible if the recorder has not already been triggered.

5.1.7.5. Settings and unloading

The setting parameters for the disturbance recorder are V parameters V240...V246 and M parameters M15, M18, M20, M80 and M81.

Unloading the recorder requires that M80 and M81 have been set. Unloading is done using a PC application. The unloaded recorder data is stored in separate files defined by the comtrade[®] format.

5.1.7.6. Event code of the disturbance recorder

The disturbance recorder generates an event code (E31) on triggering of the recorder by default. The event mask is defined using serial parameter V158.

5.1.8. Recorded data of the last events

The REJ 527 records up to five events. This enables the user to analyze the last five fault situations in the electrical power network. Each event includes the measured zero-sequence voltage, non-directional earth-fault current, directional earth-fault current and phase angle, start durations, and the time stamp. Additionally, information on the number of starts is provided.

Recorded data and the number of starts are non-volatile by default. A master reset will erase the contents of the recorded events and the number of starts.

The REJ 527 will start to collect data from all the stages when a protection function starts. When each stage has dropped off, the collected data and the time stamp will be stored in the first event register and the four previously stored events will move one step forward. When a sixth event is stored, the oldest event will be cleared.

Table 5.1.8-1 Recorded data

REGISTER	Recorded data
EVENT1	<ul style="list-style-type: none"> The zero-sequence voltage, U_0, the earth-fault current, I_0, the directional earth-fault current, I_ϕ, and the phase angle, ϕ, measured as percentages of the rated voltage and current. The angle is shown in degrees. Duration of the last starts of stages $t_{b>}$, $t_{0>}$ and $t_{0>>}$, expressed as a percentage of the set operate time, or of the calculated operate time at IDMT characteristic. The timing will start when a stage starts. A value other than zero means that the corresponding stage has started whereas a value which is 100% of the set or calculated operate time means that the stage has tripped. If the operate time for a stage has elapsed but is blocked, the value will be 99% of the set or calculated operate time. Time stamp for the event; date and time. The time when the last stage drops off will be stored. The time stamp is displayed in two registers, one including the date expressed as yy-mm-dd, and the other including the time expressed as HH.MM; SS.sss.
EVENT 2	Same as EVENT 1.
EVENT 3	Same as EVENT 1.
EVENT 4	Same as EVENT 1.
EVENT 5	Same as EVENT 1.
Number of starts	<ul style="list-style-type: none"> The number of times each protection stage, i.e. $U_{0b>}$, $I_{0>}$ and $I_{0>>}$, has started, counting up to 999.

5.1.9.

External serial communication

5.1.9.1.

Communication ports

The REJ 527 is provided with two serial communication ports: an optical PC-connection on the front panel and an RS-485 connection on the rear panel.

The D9S-type RS-485 connector is used to connect the relay to the distribution automation system. This connection enables the use of either the SPA bus communication protocol or the IEC 60870-5-103 communication protocol. The fibre-optic interface module RER 103 is used to connect the relay to the fibre-optic communication bus.

Although the RER 103 supports LON bus communication, the REJ 527 does not support the LON protocol. LON communication requires a separate LSG device.

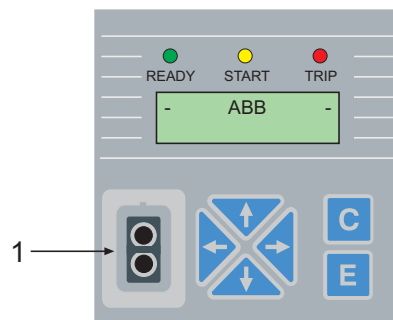

A0501299

Fig. 5.1.9.1.-1 Front connector (1) for local communication

The relay is connected to a PC used for setting via the optical PC-connector on the front panel. The front interface uses the SPA bus protocol.

The optical PC-connector galvanically isolates the PC from the relay. The connection consists of a transmitter stage and a receiver stage. The front connector is standardized for ABB relay products and requires a specific opto-cable (ABB art. no 1MKC950001-2). The cable is connected to the serial RS-232C port of the PC. The optical stage of the cable is powered by RS-232C control signals.

The following serial communication parameters are to be used for RS-232C:

Number of data bits:	7
Number of stop bits:	1
Parity:	even
Baud rate:	9.6 kbps as default

Relay data, such as events, setting values and all input data and memorized values can be read via the optical PC-interface.

When setting values are altered via the optical PC-interface, the relay will check that the entered parameter values are within the permitted setting range. If an entered value is too high or too low, the setting value will remain unchanged.

The REJ 525 has an internal counter which can be accessed via “COMMUNICATION” under “CONFIGURATION” in the HMI menu. The counter value is set to 0 when the relay receives a valid message.

5.1.9.2.

IEC 60870-5-103 remote communication protocol

The REJ 527 supports the IEC 60870-5-103 remote communication protocol (henceforward referred to as the IEC_103) in the unbalanced transmission mode. The IEC_103 protocol is used to transfer measurand and status data from the slave to the master. However, the IEC_103 protocol cannot be used to transfer disturbance recorder data.

The IEC_103 protocol can be used only through the RS-485 connection on the rear panel. Connecting the REJ 527 to the fibre-optic communication bus requires the use of the fibre-optic interface module RER 103. The line-idle state of the RER 103 is “light off” whereas it is “light on” according to the IEC_103 standard. Therefore, to achieve full compatibility in the physical layer between the relay and the master, the

IEC 60870-5-103 star coupler RER 125 is required. The RER 125 is used to set the line-idle state “light off” to the relay and “light on” to the master. However, the RER 125 is not required if the master is compatible with the line-idle state “light off”.

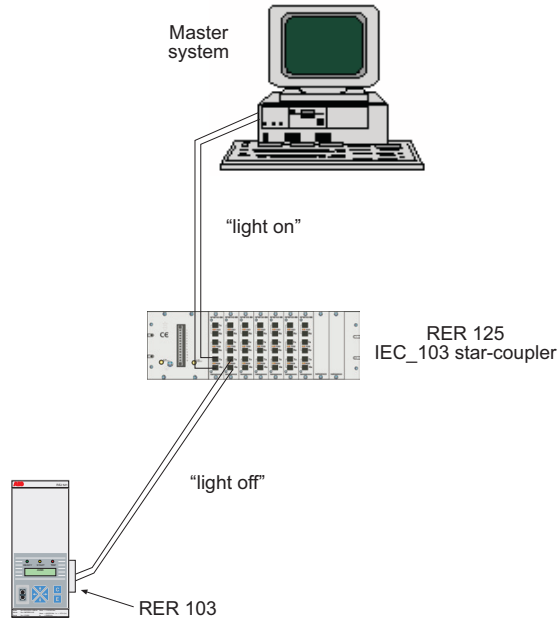

A0501300

Fig. 5.1.9.2.-1 REJ 527 communication using the IEC_103 protocol

The REJ 527 will use the SPA bus protocol as default when the rear connection is in use. The IEC_103 protocol can be selected through the HMI of the relay. The selection is memorized and will therefore always be activated when the rear connection is in use. The use of the IEC_103 protocol in the REJ 527 requires a baud rate of 9.6 kbps. When the IEC_103 protocol has been selected, event masks are not in use. Therefore, all events in the configuration set are included in the event reporting.

The REJ 527 is provided with three different selectable configuration sets, of which configuration set 1 is used by default. Configuration set 1 provides full compatibility according to the IEC_103 standard and can be used when the earth-fault unit has been configured to be non-directional ($SGF2/7=0$, $SGF3/1=1$ and $SGF3/3=1$). Configuration sets 2 and 3 provide all applicable information of the protection equipment. However, some information elements have been mapped to a private range. Configuration set 2 can be used when the earth-fault unit operates as a two-stage earth-fault current unit with a voltage deblocking facility ($SGF2/7=0$). Low-set stage $I_{0>}$ and high-set stage $I_{0>>}$ can be configured to be either directional or non-directional ($SGF3/1$ and $SGF3/3$). Configuration set 3 can be used when the unit comprises a three-stage zero-sequence voltage unit ($SGF2/7=1$). Configuration set 255 is reserved for future use.

The tables below indicate the information mapping of the corresponding configuration sets. The column GI indicates whether the status of the specified information object is transmitted within the general interrogation cycle. The relative time in messages with the type identification 2 is calculated as a time difference between the occurred event and the event specified in the column Relative time. The

measurand multiplied by the normalize factor is proportional to the rated value. Therefore, the maximum value of each measurand is the normalize factor multiplied by the rated value.

Table 5.1.9.2-1 Information mapping of configuration set 1

Event reason	Event code	Function type	Information number	Standard description of the information number (IEC 60870-5-103)	GI	Relative time	Type identification
$I_0 >$ Start Activated/Reset	E5/ E6	160	67	start/pick-up N	X	E5	2
$I_0 >$ Trip Activated/Reset	E7/ E8	160	92	trip IN>	-	E5	2
$I_0 >>$ Trip Activated/Reset	E11/ E12	160	93	trip IN>>	-	E5	2
PO1 Activated/Reset	E13/ E14	160	27	auxiliary input 1	X	-	1
PO2 Activated/Reset	E15/ E16	160	28	auxiliary input 2	X	-	1
SO1 Activated/Reset	E17/ E18	160	29	auxiliary input 3	X	-	1
SO2 Activated/Reset	E19/ E20	160	30	auxiliary input 4	X	-	1

Table 5.1.9.2-2 Information mapping of configuration set 1

Measurand	Normalize factor	Rated value	Function type	Information number	Standard description of the information number (IEC 60870-5-103)	Type identification
Current I_0	2.40	I_n	160	147	measurand I	3.4
Voltage U_0	2.40	U_n				

Table 5.1.9.2-3 Information mapping of configuration set 2

Event reason	Event code	Function type	Information number	Standard description of the information number (IEC 80870-5-103)	GI	Relative time	Type identification
$U_{0b} >$ Start Activated/Reset	E1/ E2	170	84	-	X	E1	2
$U_{0b} >$ Trip Activated/Reset	E3/ E4	170	90	-	-	E1	2
$I_0 >$ Start Activated/Reset	E5/ E6	163 ¹⁾ (160)	67	- (start/pick-up N)	X	E5	2

Table 5.1.9.2-3 Information mapping of configuration set 2 (Continued)

Event reason	Event code	Function type	Information number	Standard description of the information number (IEC 80870-5-103)	GI	Relative time	Type identification
$I_0 >$ Trip Activated/Reset	E7/ E8	163 ¹⁾ (160)	92	- (trip $I_{N>}$)	-	E5	2
$I_0 >>$ Start Activated/Reset	E9/ E10	163 ²⁾ 162	95	- (-)	X	E9	2
$I_0 >>$ Trip Activated/Reset	E11/ E12	163 ²⁾ (160)	93	- (trip $I_{N>>}$)	-	E9	2
PO1 Activated/Reset	E13/ E14	163	27	-	X	-	1
PO2 Activated/Reset	E15/ E16	163	28	-	X	-	1
SO1 Activated/Reset	E17/ E18	163	29	-	X	-	1
SO2 Activated/Reset	E19/ E20	163	30	-	X	-	1
Disturbance recorder triggered	E31	163	100	-	-	-	1
HMI Password Opened/Closed	E32/ E33	163	101	-	-	-	1

¹⁾ If stage $I_0 >$ has been configured to be non-directional (SGF3/1=1), the function type in brackets will be used.

²⁾ If stage $I_0 >>$ has been configured to be non-directional (SGF3/3=1), the function type in brackets will be used.

Table 5.1.9.2-4 Information mapping of configuration set 2

Measurand	Normalize factor	Rated value	Function type	Information number	Standard description of the information number (IEC 60870-5-103)	Type identification
Voltage U_0	2.40	U_n	135	141	-	9
Current I_0	2.40	I_n				
Current I_φ	2.40	I_n				
Phase angle (φ)	2.40	75°				

Table 5.1.9.2-5 Information mapping of configuration set 3

Event reason	Event code	Function type	Information number	Standard description of the information number (IEC 80870-5-103)	GI	Relative time	Type identification
U _{0b} > Start Activated/Reset	E1/ E2	170	84	-	X	E1	2
U _{0b} > Trip Activated/Reset	E3/ E4	170	90	-	-	E1	2
U ₀ > Start Activated/Reset	E5/ E6	170	94	-	X	E5	2
U ₀ > Trip Activated/Reset	E7/ E8	170	91	-	-	E5	2
U ₀ >> Start Activated/Reset	E9/ E10	170	96	-	X	E9	2
U ₀ >> Trip Activated/Reset	E11/ E12	170	98	-	-	E9	2
PO1 Activated/Reset	E13/ E14	170	27	-	X	-	1
PO2 Activated/Reset	E15/ E16	170	28	-	X	-	1
SO1 Activated/Reset	E17/ E18	170	29	-	X	-	1
SO2 Activated/Reset	E19/ E20	170	30	-	X	-	1
Disturbance recorder triggered	E31	170	100	-	-	-	1
HMI Password Opened/Closed	E32/ E33	170	101	-	-	-	1

Table 5.1.9.2-6 Information mapping of configuration set 3

Measurand	Normalize factor	Rated value	Function type	Information number	Standard description of the information number (IEC 60870-5-103)	Type identification
Voltage U ₀	2.40	U _n	135	141	-	9
Current I ₀	2.40	I _n				
Current I _φ	2.40	I _n				
Phase angle (φ)	2.40	75°				

5.1.9.3.**Event codes**

Special codes have been determined to represent certain events, such as start and tripping of protection stages and different states of output signals.

Events E1...E51 are stored in the event register of the relay. The maximum capacity of the register is 60 events. Under normal conditions the register is empty.

The contents of the register can be read using the L command, five events at a time. Using the L command erases the previously read events from the register, with the exception of events E50 and E51 which have to be reset using the C command. Should a fault occur, for example in data communication, these events can be re-read using the B command. If needed, the B command can also be repeated.

Events to be included in the event reporting are marked with multiplier 1. The event mask is formed by the sum of the weighting factors of all those events which are to be included in the event reporting.

Table 5.1.9.3-1 Event masks

Event mask	Code	Setting range	Default setting
V155	E1...E8	0...255	85
V156	E9...E12	0...15	5
V157	E13...E20	0...255	3
V158	E31	0 or 1	1

Table 5.1.9.3-2 Event codes E1...E8

Code	Event	Weighting factor	Default value
E1	Start of stage $U_{0b}>$	1	1
E2	Start of stage $U_{0b}>$ reset	2	0
E3	Trip of stage $U_{0b}>$	4	1
E4	Trip of stage $U_{0b}>$ reset	8	0
E5	Start of stage $I_0>$ or $U_0>$	16	1
E6	Start of stage $I_0>$ or $U_0>$ reset	32	0
E7	Trip of stage $I_0>$ or $U_0>$	64	1
E8	Trip of stage $I_0>$ or $U_0>$ reset	128	0
Default value of event mask V155			85

Table 5.1.9.3-3 Event codes E9...E12

Code	Event	Weighting factor	Default value
E9	Start of stage $I_0>>$ or $U_0>>$	1	1
E10	Start of stage $I_0>>$ or $U_0>>$ reset	2	0
E11	Trip of stage $I_0>>$ or $U_0>>$	4	1
E12	Trip of stage $I_0>>$ or $U_0>>$ reset	8	0
Default value of event mask V156			5

Table 5.1.9.3-4 Event codes E13...E20

Code	Event	Weighting factor	Default value
E13	PO1 activated	1	1
E14	PO1 reset	2	1
E15	PO2 activated	4	0
E16	PO2 reset	8	0
E17	SO1 activated	16	0
E18	SO1 reset	32	0
E19	SO2 activated	64	0
E20	SO2 reset	128	0
Default value of event mask V157			3

Table 5.1.9.3-5 Event codes E31...E33

Code	Event	Weighting factor	Default value
E31	Disturbance recorder triggered	1	1
E32	HMI password opened	2	0
E33	HMI password reclosed	4	0
Default value of event mask V158			1

Explanations of the default values:

0 = not included in the event reporting

1 = included in the event reporting

Table 5.1.9.3-6 Event codes E50 and E51

Code	Event
E50	Restart of relay
E51	Overflow of event register

Events E50 and E51 are always included in the event reporting.

5.1.9.4.

SPA bus communication protocol parameters

In some cases, altering parameter values via serial communication requires the use of the SPA password. The password is a number within the range 1...999, the default value being 1.

To enter the setting mode, enter the password into parameter V160. To quit the setting mode, enter the same password into parameter V161. The password protection is also reactivated in case of loss of auxiliary voltage.

The HMI password can be changed via parameter V162, but it is not possible to read the password via this parameter.

Abbreviations used in the following tables:

- R = readable data
- W = writeable data
- P = password protected writeable data
- I = input data

- S = setting values
- V = recorded data/parameter
- M = disturbance recorder parameter
- O = output data

Settings

Table 5.1.9.4-1 Settings

Variable	Actual settings (R)	Group 1 (R, W, P)	Group 2 (R, W, P)	Setting range
Set start value of stage $I_{0>}$	S1	S41	S81	1.0...100% x I_n
Set start value of stage $U_{0>}$	S2 ¹⁾	S42	S82	2.0...80.0% x U_n
Operate time of stage $I_{0>}/U_{0>}$	S3 ¹⁾	S43	S83	0.10...300 s
Time multiplier k of stage $I_{0>}$	S4 ¹⁾	S44	S84	0.05...1.00 ²⁾
Set start value of stage $I_{0>>}$	S5 ¹⁾	S45	S85	5.0...400% x I_n
Set start value of stage $U_{0>>}$	S6 ¹⁾	S46	S86	2.0...80.0% x U_n
Operate time of stage $I_{0>>}/U_{0>>}$	S7	S47	S87	0.10...300 s
Set start value of stage $U_{0b>}$	S8	S48	S88	2.0...80.0% x U_n
Operate time of stage $U_{0b>}$	S9	S49	S89	0.10...300 s
Additional angle (φ_a) of stage $I_{0>}/I_{0>>}$ with the basic angle	S10 ¹⁾	S50	S90	0...90°
Basic angle (φ_b) of stage $I_{0>}/I_{0>>}$	S11 ¹⁾	S51	S91	-90...0°
Angle correction (φ_c) of stage $I_{0>}/I_{0>>}$ with the I_φ characteristic	S12 ¹⁾	S52	S92	2...7°
Checksum, SGF1	S13	S53	S93	0...31
Checksum, SGF2	S14	S54	S94	0...255
Checksum, SGF3	S15	S55	S95	0...255
Checksum, SGF4	S16	S56	S96	0...32
Checksum, SGF5	S17	S57	S97	0...4
Checksum, SGB1	S18	S58	S98	0...255
Checksum, SGR1	S19	S59	S99	0...15
Checksum, SGR2	S20	S60	S100	0...15
Checksum, SGR3	S21	S61	S101	0...15
Checksum, SGR4	S22	S62	S102	0...15
Checksum, SGR5	S23	S63	S103	0...15
Checksum, SGR6	S24	S64	S104	0...15
Operate time of CBFP	-	S121	S121	0.10...1.00 s
Time setting for disabling new trip indications on the LCD	-	S122	S122	0...999 min

¹⁾ If the protection stage has been set out of operation, the number indicating the currently used value will be displaced by "999" when parameters are read via the SPA bus and by dashes on the LCD.

²⁾ Values above 1 equal 1.

Recorded data

Parameters V1...V3 show the number of starts of the protection stages and parameter V4 the trip indication code.

Table 5.1.9.4-2 Recorded data: Parameters V1...V4

Recorded data	Parameter	R, W	Value
Number of starts of stage $U_{0b}>$	V1	R	0...999
Number of starts of stage $I_0>/U_0>$	V2	R	0...999
Number of starts of stage $I_0>>/U_0>>$	V3	R	0...999
Trip indication code	V4	R	0=--- 1= $U_{0b}>$ 2= $t_b>$ 3= $I_0>$ or $U_0>$ 4= $t_0>$ 5= $I_0>>$ or $U_0>>$ 6= $t_0>>$ 9=CBFP

The last five recorded values can be read with parameters V11...V99. Event n denotes the last recorded value, n-1 the next one, and so forth.

Table 5.1.9.4-3 Recorded data

Recorded data	Event (R)					Value
	n	n-1	n-2	n-3	n-4	
Zero-sequence voltage, U_0	V11	V31	V51	V71	V91	0...400% x U_n
Earth-fault current I_0	V12	V32	V52	V72	V92	0...800% x I_n
Earth-fault current I_φ	V13	V33	V53	V73	V93	0...±800% x I_n
Phase angle, φ	V14	V34	V54	V74	V94	0...±180° ¹⁾
Start duration, stage $U_{0b}>$	V15	V35	V55	V75	V95	0...100%
Start duration, stage $I_0>$ or $U_0>$	V16	V36	V56	V76	V96	0...100%
Start duration, stage $I_0>>$ or $U_0>>$	V17	V37	V57	V77	V97	0...100%
Time stamp of the registered value, date	V18	V38	V58	V78	V98	YY-MM-DD
Time stamp of the registered value, time	V19	V39	V59	V79	V99	HH.MM; SS.sss

¹⁾ If the measured current or voltage values are too low, "+999" will be shown.

Disturbance recorder

Table 5.1.9.4-4 Parameters for the disturbance recorder

Description	Parameter	R, W	Value/Note
Manual triggering	M1 ¹⁾	W	1
Clear recorder memory	M2	W	1
Sampling rate	M15 ²⁾	R, W	800/960 Hz 400/480 Hz 50/60 Hz
Station identification/unit number	M18	R, W	0...9999
Rated frequency	M19	R	50 or 60 Hz
Station name	M20	R, W	Max 16 characters
Digital channel texts	M40...46	R	
Analogue channel texts	M60...61	R	
Analogue channel: rated voltage and unit of primary voltage transformer	M80 ³⁾	R, W	Factor 0.00...600, unit (V, kV), e.g. 20.0,kV)
Analogue channel: conversion factor and unit, I ₀	M81 ³⁾	R, W	Factor 0...65535, unit (A, kA), e.g. 10.0,kA
Post-triggering recording length	V240	R, W	0...100%
Internal trigger signals' checksum	V241	R,W	0...63, see table 5.1.9.4-5
Internal trigger signal's edge	V242	R,W	0...63; 0 = rising, 1 = falling
External trigger signal (BI)	V243	R,W	0/1, see table 5.1.9.4-6
External trigger signal's edge	V244	R,W	0/1; 0 = rising, 1 = falling
Triggering state, clearing and restart	V246	R,W	R: 0 = recorder not triggered 1 = recorder triggered and recording stored in the memory W: 0 = clear recorder memory 2 = download restart; sets the first information and the time stamp for triggering ready to be read 4 = manual triggering

¹⁾ M1 can be used for broadcast triggering by using the unit address "900".

²⁾ Parameters can be written when the recorder has not been triggered.

³⁾ The disturbance recorder requires this parameter to be set. The conversion factor is the transformation ratio multiplied by the rated current of the relay. If this parameter has been given the default value 0, dashes will be shown on the LCD instead of the primary values and the recorded data will be redundant.

Table 5.1.9.4-5 Disturbance recorder internal triggering

Event	Weighting factor	Default value of triggering mask, V241	Default value of triggering edge, V242
Start of stage $U_{0b}>$	1	0	0
Trip of stage $U_{0b}>$	2	0	0
Start of stage $I_0>$ or $U_0>$	4	0	0
Trip of stage $I_0>$ or $U_0>$	8	1	0
Start of stage $I_0>>$ or $U_0>>$	16	0	0
Trip of stage $I_0>>$ or $U_0>>$	32	0	0
Not in use	-	0	0
Not in use	-	0	0
Checksum		8	0

Table 5.1.9.4-6 Disturbance recorder external triggering

Event	Weighting factor	Default value of triggering mask, V243	Default value of triggering edge, V244
External BI *)	1	1	0
Not in use	-	0	0
Not in use	-	0	0
Not in use	-	0	0
Not in use	-	0	0
Not in use	-	0	0
Not in use	-	0	0
Not in use	-	0	0
Checksum		1	0

*) Note that the value of SGB1/3 has to be 0 (indications, output contacts and memorized values will not be reset by the binary input signal).

Control parameters

Table 5.1.9.4-7 Control parameters

Description	Parameter	R, W	Value
Unlatching output contacts	V101	W	1 = unlatch
Clearing registers and unlatching output contacts	V102	W	1 = clear and unlatch
Rated frequency	V133	R,W (P)	50=50 Hz 60=60 Hz
Nominal voltage	V134	R,W (P)	100, 110, 115, 120 (V)
Remote control of settings	V150	R,W	0 = setting group 1 1 = setting group 2
Non-volatile memory settings	V152	R, W	0...31
Event mask for $I_0>$, $U_0>$ and $U_{0b}>$	V155	R,W	0...255, see Event codes
Event mask for $I_0>>$ and $U_0>>$	V156	R,W	0...15, see Event codes
Event mask for output contacts' events	V157	R,W	0...255, see Event codes
Event mask for the disturbance recorder and the HMI password	V158	R,W	0...7, see Event codes

Table 5.1.9.4-7 Control parameters (Continued)

Description	Parameter	R, W	Value
Entering the SPA password for settings	V160	W	1...999
Changing the SPA password or reinstating the password protection	V161	W (P)	1...999
Changing the HMI password	V162	W	1...999
Activating the self-supervision	V165	W	1 = the self-supervision output contact is activated and the READY indicator LED starts to blink 0 = normal operation
LED test for start and trip indicators	V166	W (P)	0 = start and trip LEDs off 1 = trip LED on, start LED off 2 = start LED on, trip LED off 3 = start and trip LEDs on
Default settings	V167	W (P)	2 = Restore factory settings
Internal fault code	V169	R	0...255
Unit address of the relay	V200	R, W	1...254
Data transfer rate, kbps	V201	R, W	4.8 or 9.6
Rear communication	V202	W	1 = rear connector activated
Relay serial number	V230	R	ERxxxxxx
CPU serial number	V231	R	MRxxxxxx
Article number	V232	R	1MRS091411(/8)-BAA
Test date	V233	R	YYYYMMDD
Software number	V234	R	1MRS118015
Software revision	V235	R	A...Z
Software build number	V236	R	
Date reading and setting (RED 500 format)	V250	R, W	YY-MM-DD
Time reading and setting (RED 500 format)	V251	R, W	HH.MM; SS.sss
Reading of an event register	L	R	Time, channel number and event code
Re-reading of an event register	B	R	Time, channel number and event code
Type designation of the relay	F	R	REJ 527
Reading of relay state data	C	R	0 = normal state 1 = relay been subject to an automatic reset 2 = overflow of an event register 3 = both events 1 and 2
Resetting of relay state data	C	W	0 = resetting all events 1 = reset only E50 2 = reset only E51 4 = reset all events including E 51 except for E50
Time reading and setting	T	R, W	00.000...59.999 s
Date and time reading and setting	D	R, W	YY-MM-DD HH.MM;SS.sss

Input and output signals

The measured values and the status of the binary input signal can be read (R) with parameters I1...I5. When the value of parameter I5 is 1, the binary input will be energized.

Table 5.1.9.4-8 Inputs

Description	Parameters (R)	Value
Measured residual voltage (U_0)	I1	0...400%
Measured earth-fault current (I_0)	I2	0...800%
Measured directional earth-fault current (I_φ)	I3	0...±800%
Measured phase angle (φ)	I4	0...±180° ¹⁾
Binary input signal	I5	0 or 1

¹⁾ If the measured current and voltage values are too low, "+999" will be shown.

Each protection stage has its internal output signal. These signals can be read (R) with parameters O1...O6. The state of the output contacts can be read (R) or changed (W) with parameters O7...O10. When the value of any of parameters O1...O10 is changed from 0 to 1, it will be recorded in the corresponding parameter O21...O30.

Table 5.1.9.4-9 Output signals

Status of the protection stages	State of stage (R)	Recorded functions (R)	Value
Start of stage $U_{0b}>$	O1	O21	0 or 1
Trip of stage $U_{0b}>$	O2	O22	0 or 1
Start of stage $I_0>$ or $U_0>$	O3	O23	0 or 1
Trip of stage $I_0>$ or $U_0>$	O4	O24	0 or 1
Start of stage $I_0>>$ or $U_0>>$	O5	O25	0 or 1
Trip of stage $I_0>>$ or $U_0>>$	O6	O26	0 or 1

Table 5.1.9.4-10 Outputs

Operation of output contacts	State of output (R, W, P)	Recorded functions (R)	Value
Output PO1	O7	O27	0 or 1
Output PO2	O8	O28	0 or 1
Output SO1	O9	O29	0 or 1
Output SO2	O10	O30	0 or 1
Enabling output contacts PO1, PO2, SO1 and SO2	O41	-	0 or 1



Parameters O7...O10 and O41 control the physical output contacts which can be connected to e.g. circuit breakers.

5.1.10. Self-supervision (IRF) system

The REJ 527 is provided with an extensive self-supervision system which continuously supervises the software and the electronics of the relay. It handles run-time fault situations and informs the user about an existing fault via a LED on the HMI and a text message on the LCD.

When a fault is detected, the relay will first try to eliminate it by restarting. Only after the fault has been found to be permanent, the READY indicator LED will start to blink and the self-supervision output contact will be activated. All other output contacts are blocked during an internal fault. Further, a fault indication message will appear on the LCD.

Fault indications have the highest priority on the HMI. None of the other HMI indications can override the IRF indication. As long as the READY indicator LED is blinking, the fault indication can not be cleared. In case an internal fault disappears, the READY indicator LED will stop blinking and the IRF relay will be returned to the normal service state, but the fault indication message will remain on the LCD.

The IRF code is the code of the last internal fault detected by the self-supervision system and describes the type of fault. When a fault appears, the code is to be recorded and given to an authorised repair shop when overhaul is ordered. For fault codes, refer to the Operator's Manual.

5.1.11. Relay parameterization**Local parameterization**

The parameters of the relay can be set either locally via the HMI or externally via serial communication with the Relay Setting Tool. When the parameters are set locally, the setting parameters can be chosen from the hierarchical menu structure. The desired language can be selected for parameter descriptions. Refer to the Operator's Manual for further information.

External parameterization

The Relay Setting Tool is used for parameterizing the relay units. Adjusting the parameter values using the Relay Setting Tool is done off-line, after which the parameters can be downloaded to the relay via a communication port.

5.2. Design description**5.2.1. Input/output connections**

All external circuits are connected to the terminals on the rear panel of the relay. Terminals X1.1-₂ are dimensioned for one 0.5...6.0 mm² wire or for two max 2.5 mm² wires and terminals X2.1-₂ for one 0.08...2.5 mm² wire or for two max 1.5 mm² wires.

The energizing voltage is connected to terminals X1.1/4-6. The nominal voltage (100/110/115/120 V) of the matching transformers has to be selected with SPA parameter V134 or via the HMI. The energizing current of the earth-fault unit is connected to terminals X1.1/1-3 (see table 5.2.1-1).

The binary input X2.1/17-18 can be used to generate an external blocking signal, to unlatch the output contacts or for remote control of relay settings. The requested function is selected in SGB. The binary input can also be used as a trigger signal for the disturbance recorder; this function is selected with SPA parameter V243.

The auxiliary voltage of the relay is connected to terminals X2.1/1-2. At DC supply, the positive lead is connected to terminal X2.1/1. For details, refer to the description of the auxiliary voltage. The permitted auxiliary voltage range of the relay is marked on the front panel of the relay.

Output contacts PO1 and PO2 are heavy-duty trip contacts capable of controlling most circuit breakers. The trip signals from the different protection stages are routed to the output contacts with switches 1 and 2 of SGR1...SGR6. On delivery from the factory, the trip signals from all the protection stages are routed to both PO1 and PO2.

Output contacts SO1 and SO2 can be used for signalling on start and tripping of the relay. The signals to be routed to output contacts SO1 and SO2 are selected with switches 3 and 4 of SGR1...SGR6. On delivery from the factory, the start signals from all the protection stages are routed to both SO1 and SO2.

Output contact IRF functions as an output contact for the self-supervision system of the protection relay. The IRF relay is energized under normal operating conditions and contact gap X2.1/13-15 is closed. When a fault is detected by the self-supervision system or the auxiliary voltage is disconnected, the output contact will drop off and contact X2.1/13-14 will close.

The following picture presents a rear view of the REJ 527, showing three connecting sockets: one for measuring transformers, one for power supply and one for serial communication.

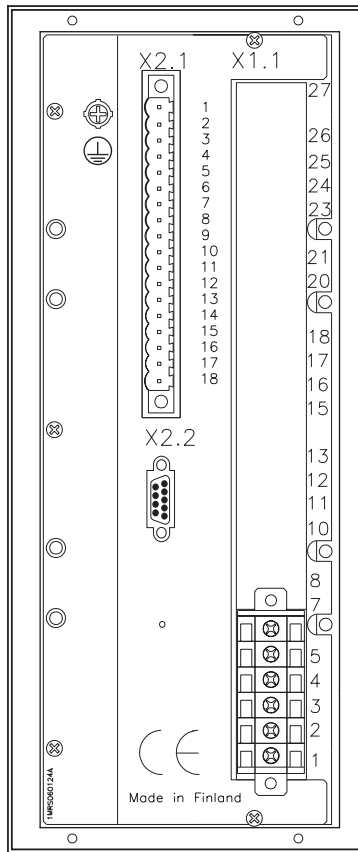

A0501432

Fig. 5.2.1.-1 Rear view of the directional earth-fault relay

Table 5.2.1-1 Inputs for earth-fault current and zero-sequence voltage

Terminal	Function	
	REJ 527B 411BAA	REJ 527B 418BAA
X1.1-1	Common	Common
X1.1-2	I_0 1 A	I_0 5 A
X1.1-3	I_0 0.2 A	I_0 1 A
X1.1-4	Common	Common
X1.1-5	Not in use	Not in use
X1.1-6	U_0	U_0

Table 5.2.1-2 Auxiliary supply voltage

Terminal	Function
X2.1-1	Input+
X2.1-2	Input-

Table 5.2.1-3 Output contacts

Terminal	Function
X2.1-3 X2.1-4	PO1, closing contact
X2.1-5 X2.1-6	PO2, closing contact
X2.1-7 X2.1-8 X2.1-9	SO1, common SO1, NC SO1, NO
X2.1-10 X2.1-11 X2.1-12	SO2, common SO2, NC SO2, NO

Table 5.2.1-4 Internal Relay Fault (IRF) contact

Terminal	Function
X2.1-13	Internal relay fault, common
X2.1-14	Closed; IRF, or U_{aux} disconnected
X2.1-15	Closed; no IRF, and U_{aux} connected

Table 5.2.1-5 Binary input

Terminal	Function
X2.1-17	Input+
X2.1-18	Input-

5.2.2.**Serial communication connections**

The REJ 527 is interfaced with a fibre-optic bus by means of the bus connection module RER 103 via the D9S-type connector X2 located on the rear panel of the device. The terminals of the fibre-optic cables are connected to the counter terminals Rx (Receiver) and Tx (Transmitter) of the bus connection module. The fibre-optic cables are linked from one protection relay to another and to the substation level communication unit, e.g. SRIO 1000M and the RER 125.

The optical PC-connection on the front panel of the relay is used to connect the relay to a fibre-optic SPA bus via opto-cable 1MKC950001-2.

Table 5.2.2-1 RS-485 connector X2 for the RER 103

Terminal	Function
X.2.2-1	Data A (data signal +)
X.2.2-2	Data B (data signal -)
X.2.2-3	RTS A (request to send +)
X.2.2-4	RTS B (request to send -)
X.2.2-5	COL A (2.8 V on relay)
X.2.2-6	COL B (2.2 V on relay)
X.2.2-7	GND
X.2.2-8	NC
X.2.2-9	+5 V DC, auxiliary voltage (max. 200 mA)

5.2.3. Technical data**Table 5.2.3-1 Dimensions ¹⁾**

Width, frame 111.4 mm, box 94 mm
Height, frame 265.9 mm (6U), box 249.8 mm
Depth 235 mm (245.1 mm with a protective rear cover, available as an option)
Enclosure size 1/4 (x 19")
Weight of the relay ~3.0 kg

¹⁾ For dimension drawings, refer to the Installation Manual (1MRS 750526-MUM).

Table 5.2.3-2 Power supply

U_{aux} rated	$U_r=10/120/220/240$ V AC $U_r=48/60/110/125/220$ V DC
U_{aux} variation	80...265 V AC 38...265 V DC
Relay power start-up time, typical	300 ms
Burden of auxiliary voltage supply under quiescent/ operating condition	~ 4 W/~ 10 W
Ripple in the DC auxiliary voltage	Max 12% of the DC value
Interruption time in the auxiliary DC voltage without resetting the relay	< 30 ms at 48 V DC < 100 ms at 110 V DC < 500 ms at 220 V DC

Table 5.2.3-3 Energizing inputs

Rated frequency	50/60 Hz \pm 5 Hz		
Current input			
Rated current, I_n	0.2 A	1 A	5 A
Thermal withstand capability			
• continuously	1.5 A	4 A	20 A
• for 1 s	20 A	100 A	500
Dynamic current withstand			
• half-wave value	50 A	250 A	1250 A
Input impedance	< 750 m Ω	< 100 m Ω	< 20 m Ω
Voltage input			
Rated voltage, U_n	100/110/115/ 120 V		
Thermal withstand capability			
• continuously	2 x U_n		
• for 10 s	3 x U_n		
Input impedance	> 4.7 M Ω		

Table 5.2.3-4 Measuring range

Measured residual voltage (U_0) as a percentage of the rated voltage of the energizing input	0...400% x U_n
Measured earth-fault current (I_0) as a percentage of the rated current of the energizing input	0...800% x I_n

Table 5.2.3-5 Binary input

Operating range	18...265 V DC
Rated voltage	$U_n=24/48/60/110/220$ V DC
Current drain	~ 2...25 mA
Power consumption	< 0.8 W

Table 5.2.3-6 Signal outputs (SO1, SO2) and self-supervision (IRF) output

Rated voltage	250 V AC/DC
Continuous carry	5 A
Make and carry for 3.0 s	8 A
Make and carry for 0.5 s	10 A
Breaking capacity when the control circuit time-constant L/R < 40 ms, at 48/110/220 V DC	1 A/0.25 A/0.15 A
Minimum contact load	100 mA at 24 V AC/DC

Table 5.2.3-7 Power outputs (PO1, PO2)

Rated voltage	250 V AC/DC
Continuous carry	5 A
Make and carry for 3.0 s	15 A
Make and carry for 0.5 s	30 A
Breaking capacity when the control circuit time-constant L/R < 40 ms, at 48/110/220 V DC	5 A/3 A/1 A
Minimum contact load	100 mA at 24 V AC/DC

Table 5.2.3-8 Enclosure class

Front side	IP 54 (flush-mounted)
Rear side, connection terminals	IP20
Note! A rear protective cover (accessory part) can be used to protect and shield the rear of the case.	

Table 5.2.3-9 Environmental tests

Specified service temperature range	-10...+55 °C
Storage temperature tests	-40...+70 °C according to the IEC 60068-2-48
Dry heat test	According to the IEC 60068-2-2
Dry cold test	According to the IEC 60068-2-1
Damp heat test, cyclic	According to the IEC 60068-2-30

Table 5.2.3-10 Electromagnetic compatibility tests

EMC immunity test level requirements consider the demands in the generic standard EN 50082-2	
1 MHz burst disturbance test, class III	According to the IEC 60255-22-1
• Common mode	2.5 kV
• Differential mode	1.0 kV
Electrostatic discharge test, class III	According to the IEC 61000-4-2 and IEC 60255-22-2
• For contact discharge	6 kV
• For air discharge	8 kV

Table 5.2.3-10 Electromagnetic compatibility tests (Continued)

Radio frequency interference tests	
• Conducted, common mode	According to the IEC 61000-4-6 and IEC 60255-22-6 (2000) 10 V (rms), f=150 kHz...80 MHz
• Radiated, amplitude-modulated	According to the IEC 61000-4-3 and IEC 60255-22-3 (2000) 10 V/m (rms), f=80...1000 MHz
• Radiated, pulse-modulated	According to the ENV 50204 and IEC 60255-22-3 (2000) 10 V/m, f=900 MHz
• Radiated, test with a portable transmitter	According to the IEC 60255-22-3, method C; f=77.2 MHz, P=6 W; f=72.25 MHz, P=5W
Fast transient disturbance tests	According to the IEC 60255-22-4 and IEC 61000-4-4
• Other terminals	4 kV
• Binary input	2 kV
Surge immunity test	According to the IEC 61000-4-5
• Power supply	4 kV, line-to-earth 2 kV, line-to-line
• I/O ports	2 kV, line-to-earth 1 kV, line-to-line
Power frequency (50 Hz) magnetic field	According to the IEC 61000-4-8 100 A/m continuous
Voltage dips and short interruptions	According to the IEC 61000-4-11 30%/10 ms 60%/100 ms >95%/5000 ms
Electromagnetic emission tests	According to the EN 55011 and EN 50081-2
• Conducted, RF-emission (Mains terminal)	EN 55011, class A, IEC 60255-25
• Radiated RF-emission	EN 55011, class A, IEC 60255-25
CE approval	Complies with the EMC directive 89/336/EEC and the LV directive 73/23/EEC

Table 5.2.3-11 Standard tests

Insulation tests	
Dielectric tests	According to the IEC 60255-5
• Test voltage	2 kV, 50 Hz, 1 min
Impulse voltage test	According to the IEC 60255-5
• Test voltage	5 kV, unipolar impulses, waveform 1.2/50 μ s, source energy 0.5 J
Insulation resistance measurements	According to the IEC 60255-5
• Isolation resistance	> 100 M Ω , 500 V DC
Mechanical tests	
Vibration tests (sinusoidal)	According to the IEC 60255-21-1, class I
Shock and bump test	According to the IEC 60255-21-2, class I

Table 5.2.3-12 Data communication

Rear interface, connector X2.2
<ul style="list-style-type: none">• RS-485 connection for the fibre-optic interface module RER 103• SPA-bus or IEC 60870-5-103 protocol• 4.8 or 9.6 kbps
Front interface
<ul style="list-style-type: none">• Optical RS-232 connection for the opto-cable• SPA bus protocol• 4.8 or 9.6 kbps

Auxiliary voltage

The REJ 527 requires a secured auxiliary voltage supply to operate. The internal power supply of the relay forms the voltages required by the relay electronics. The power supply is a galvanically isolated (flyback-type) DC/DC converter. When the auxiliary voltage is connected, the READY indicator LED on the front panel will be on. For detailed information on power supply, refer to table 5.2.3-2.

The primary side of the power supply is protected with a fuse located on the PCB of the relay. The fuse size is 3.15 A (slow).

6. Ordering information

Order number (I ₀ inputs 0.2 A/1 A)	REJ527B 411BAA (Article nr:1MRS091411-BAA)
Order number (I ₀ inputs 1 A/5 A)	REJ527B 418BAA (Article nr:1MRS091418-BAA)
Protective cover for rear connectors	1MRS060132
Flush mounting kit	1MRS050209
Semi-flush mounting kit	1MRS050253
Wall mounting kit	1MRS050240
Side-by-side mounting kit	1MRS050241
19" Rack mounting kit	1MRS050257
Optic bus connection module	1MRS090701 (RER 103)
Opto-cable	1MKC950001-2

7. Abbreviations

φ_a	Additional angle
φ_b	Basic angle
φ_c	Angle correction factor
BI	Binary input
CBFP	Circuit-breaker failure protection
CPU	Central processing unit
CT	Current transformer
IDMT	Inverse definite minimum time characteristic
IEC_103	Standard IEC 60870-5-103
IRF	Internal relay fault
$I_0>$	Low-set earth-fault current stage
$I_0>>$	High-set earth-fault current stage
LCD	Liquid Crystal Display
LED	Light-emitting diode
LSG	LON [®] /SPA Gateway, SPA-ZC 102
HMI	Human-Machine Interface
PCB	Printed Circuit Board
PO1, PO2	Power outputs
SGB	Switchgroup for binary input
SGF	Switchgroups for functions
SGR	Switchgroups for output contacts
SO1, SO2	Signal outputs
$U_{0b}>$	Zero-sequence voltage stage
$U_0>$	Low-set zero-sequence voltage stage
$U_0>>$	High-set zero-sequence voltage stage
VT	Voltage transformer

8. Check lists

Table 8.-1 Setting group 1

Variable	Group 1 (R, W, P)	Setting range	Default setting	Customer's setting
Set start value of stage $I_{0>}$	S41	1.0...100% x I_n	1.0% x I_n	
Set start value of stage $U_{0>}$	S42	2.0...80.0% x U_n	2.0% x U_n	
Operate time of stage $I_{0>}/U_{0>}$	S43	0.10...300 s	0.10 s	
Time multiplier k of stage $I_{0>}$	S44	0.05...1.00	0.05	
Set start value of stage $I_{0>>}$	S45	5.0...400% x I_n	5.0% x I_n	
Set start value of stage $U_{0>>}$	S46	2.0...80.0% x U_n	2.0% x U_n	
Operate time of stage $I_{0>>}/U_{0>>}$	S47	0.10...300 s	0.10 s	
Set start value of stage $U_{0b>}$	S48	2.0...80.0% x U_n	2.0% x U_n	
Operate time of stage $U_{0b>}$	S49	0.10...300 s	0.10 s	
Additional angle (φ_a) of stage $I_{0>}/I_{0>>}$ with the basic angle	S50	0...90°	0°	
Basic angle (φ_b) of stage $I_{0>}/I_{0>>}$	S51	-90...0°	-90°	
Angle correction (φ_c) of stage $I_{0>}/I_{0>>}$ with the I_φ characteristic	S52	2...7°	2°	
Checksum, SGF1	S53	0...31	0	
Checksum, SGF2	S54	0...255	0	
Checksum, SGF3	S55	0...255	0	
Checksum, SGF4	S56	0...32	0	
Checksum, SGF5	S57	0...4	0	
Checksum, SGB1	S58	0...255	0	
Checksum, SGR1	S59	0...15	12	
Checksum, SGR2	S60	0...15	3	
Checksum, SGR3	S61	0...15	12	
Checksum, SGR4	S62	0...15	3	
Checksum, SGR5	S63	0...15	12	
Checksum, SGR6	S64	0...15	3	

Table 8.-2 Setting group 2

Variable	Group 2 (R, W, P)	Setting range	Default setting	Customer's setting
Set start value of stage $I_{0>}$	S81	1.0...100% x I_n	1.0% x I_n	
Set start value of stage $U_{0>}$	S82	2.0...80.0% x U_n	2.0% x U_n	
Operate time of stage $I_{0>}/U_{0>}$	S83	0.10...300 s	0.10 s	
Time multiplier k of stage $I_{0>}$	S84	0.05...1.00	0.05	
Set start value of stage $I_{0>>}$	S85	5.0...400% x I_n	5.0% x I_n	
Set start value of stage $U_{0>>}$	S86	2.0...80.0% x U_n	2.0% x U_n	
Operate time of stage $I_{0>>}/U_{0>>}$	S87	0.10...300 s	0.10 s	
Set start value of stage $U_{0b>}$	S88	2.0...80.0% x U_n	2.0% x U_n	
Operate time of stage $U_{0b>}$	S89	0.10...300 s	0.10 s	
Additional angle (φ_a) of stage $I_{0>}/I_{0>>}$ with the basic angle	S90	0...90°	0°	
Basic angle (φ_b) of stage $I_{0>}/I_{0>>}$	S91	-90...0°	-90°	
Angle correction (φ_c) of stage $I_{0>}/I_{0>>}$ with the I_φ characteristic	S92	2...7°	2°	
Checksum, SGF1	S93	0...31	0	
Checksum, SGF2	S94	0...255	0	
Checksum, SGF3	S95	0...255	0	
Checksum, SGF4	S96	0...32	0	
Checksum, SGF5	S97	0...4	0	
Checksum, SGB1	S98	0...255	0	
Checksum, SGR1	S99	0...15	12	
Checksum, SGR2	S100	0...15	3	
Checksum, SGR3	S101	0...15	12	
Checksum, SGR4	S102	0...15	3	
Checksum, SGR5	S103	0...15	12	
Checksum, SGR6	S104	0...15	3	

Table 8.-3 Control parameters

Variable	Parameter	Setting range	Default setting	Customer's setting
Rated frequency	V133	50/60	50	
Nominal voltage	V134	100/110/115/120	100	
Remote control of settings	V150	0/1	0	
Non-volatile memory settings	V152	0...31	31	
Event mask for $I_0>$, $U_0>$ and $U_{0b}>$	V155	0...255	85	
Event mask for $I_0>>$ and $U_0>>$	V156	0...15	5	
Event mask for output contacts' events	V157	0...255	3	
Event mask for the disturbance recorder and the HMI password	V158	0...7	1	
Unit address of the relay	V200	1...254	1	
Data transfer rate	V201	4.8 or 9.6 kbps	9.6	
Operate time of the CBFP	S121	0.10...1.00 s	0.10	
Time setting for disabling new trip indications on the LCD	S122	0...999 min	60	

Table 8.-4 Parameters for the disturbance recorder

Information	Parameter	Setting range	Default setting	Customer's setting
Post-triggering recording length in percent	V240	0...100%	50%	
Internal trigger signals' checksum	V241	0...63	8	
Internal trigger signal's edge	V242	0...63	0	
External trigger signal (BI)	V243	0/1	1	
External trigger signal's edge	V244	0/1	0	
Sampling rate	M15	800/960 Hz 400/480 Hz 50/60 Hz	800/960 Hz	
Station identification/unit number	M18	0...9999	0000	
Station name	M20	Max 15 characters	- ABB -	
Analogue channel: rated voltage and unit of primary voltage transformer	M80	Rated voltage 0.00...600; unit V or kV	0.00,kV	
Analogue channel: conversion factor and unit, I_0	M81	Factor 0...65535; unit A or kA	00000, A	

9. Service

When the protection relay is used under the conditions specified in Section 5.2.3. Technical data, it is practically maintenance-free. The protection relay electronics include no parts or components subject to abnormal physical or electrical wear under normal operating conditions.

If the relay fails in operation or if the operating values considerably differ from those mentioned in the protection relay specifications, the relay should be overhauled. All repairs are to be taken by the manufacturer. Please contact the manufacturer or its nearest representative for further information about checking, overhaul and recalibration of the relay.



To achieve the best possible operation accuracy, all parts of the protection relay have been calibrated together. In the event of malfunction, please consult your relay supplier.

If the protection relay is sent to the manufacturer, it has to be carefully packed to prevent further damage to the device.

10.**Index****A**

Application	11
Auxiliary voltage	61, 63, 66

B

Basic angle	17, 33, 36, 38, 41, 53
Binary input	62, 64
Binary input test	42
Block diagram	17

C

CBFP	14
Check lists	71
Checksum calculation	33
Communication ports	45
Communication protocol	46
Comtrade	44
Configuration	16
Connection diagram	12
Control parameters	56, 73
Cos(j) characteristics	17, 19, 36, 38
Counter	46

D

Data communication	66
Design description	59
Dimensions	63
Directional earth-fault current	17
Directional element	41
Disturbance recorder	14, 42, 55
Disturbance recorder data	42

E

Earth-fault current	17, 19, 20
Electromagnetic compatibility tests	64
Energizing inputs	63
Environmental conditions	11
Environmental tests	64
Event codes	44, 51, 52
External parameterization	59

F

Fault code	15, 59
Features	9
Function test	42

H	
HMI	14, 32
I	
IEC 60255 standard	23
IEC 60870-5-103	46
Indication messages	41, 59
Input/output connections	59
Input/output signals	58
Inputs	14, 58
Intermittent earth-fault	22, 37
Internal relay fault	15, 59, 62
L	
Latching feature	34
LCD	14, 59
LED	15, 41, 59
LED test	42
Local parameterization	59
LON bus	45
M	
Master reset	44
Measurements	15
Measuring range	63
N	
New trip indication	39
Non-directional earth-fault current	17
Non-volatile memory	15, 39
O	
Operation direction	20, 40
Ordering information	67
Output signals	58
P	
Parameterization	59
Parameters for the disturbance recorder	55, 73
Password	14, 52
Power outputs (PO1, PO2)	14, 62, 64
Power supply	63
Product functions	13

R

RD-type characteristic	25
Recorded data	44, 54
Requirements	11
RI-type characteristic	24

S

Self-supervision	15, 59
Serial communication	45, 62
Setting groups	32, 71, 72
Settings	32, 53
SGB1	38
SGF1...SGF5	34
SGR1...SGR6	38, 60
Signal diagram	16
Signal outputs (SO1, SO2)	14, 62, 64
Sin(j) characteristics	17, 36, 38
SPA bus communication protocol	45
Switchgroups	33

T

Technical data	63
Technical data on protection functions	40
Time/current characteristics	23

W

Weighting factor	33
------------------------	----

Z

Zero-sequence voltage	17, 21
-----------------------------	--------



ABB Oy

Distribution Automation

P.O. Box 699

FI-65101 Vaasa

FINLAND

Tel. +358 10 22 11

Fax. +358 10 224 1094

www.abb.com/substationautomation