



Relion® 615 series

# Motor protection and control REM615

# Compact and versatile solution for industrial power distribution systems

**REM615 is a dedicated motor protection and control IED perfectly aligned for the protection, control, measurement and supervision of asynchronous motors in manufacturing and process industry.**

**REM615 is a member of ABB's Relion® protection and control product family and its 615 series. The 615 series IEDs are characterized by their compactness and withdrawable-unit design. Re-engineered from the ground up, the new 615 series has been designed to unleash the full potential of the IEC 61850 standard for communication and interoperability between substation automation devices.**

## Application

REM615 constitutes main protection for asynchronous motors and their drives in manufacturing and process industry. REM615 is available in three standard configurations. Typically, the motor IED is used with circuit-breaker or contactor controlled HV motors, and contactor controlled medium sized and large LV motors in a variety of drives, including both continuously and intermittently operated asynchronous motors with varying load.

## Protection and control

REM615 offers all the functionality needed to manage motor starts and normal operation also including protection and fault clearance in drive and network disturbance situations. The main features of the motor IED include thermal overload protection, motor start-up time supervision, locked rotor protection and protection against too frequent motor starts. The IED also incorporates non-directional earth-fault protection, negative phase sequence current unbalance protection and backup overcurrent protection. Furthermore, the IED offers motor running stall protection, loss-of-load supervision and phase-reversal protection.

Standard configurations B and C additionally offer directional earth-fault protection, three phase undervoltage protection, negative phase sequence overvoltage and positive sequence undervoltage protection. In addition, the B and C configurations offer frequency protection including over-frequency, underfrequency and rate-of-change frequency protection modes.

The motor IED has been thoroughly adapted for earth-fault protection. Using cable current transformer sensitive and

reliable earth-fault protection can be achieved. Phase current transformers in Holmgreen (summation) connection can also be used the residual current measurement. In this case possible unwanted operations of the earth-fault protection due to CT saturation at motor start-up can be prevented using the IED's internal interlocking features or a suitable stabilizing resistor in the neutral return path.

The optional RTD/mA module offered for standard configurations A and B facilitates the measurement of up to eight analog signals via the six RTD inputs or the two transducer derived analog signals via the mA inputs. The RTD and mA inputs can be used for temperature measurement of motor bearings and windings, thus extending the functionality of the thermal overload protection and preventing premature aging of the motor winding. Furthermore, the RTD and mA inputs can be used for measuring the ambient air temperature. The RTD/mA module enables the use of the optional multipurpose protection functions, which can be applied for tripping and alarm purposes based on RTD and mA measuring data or analog values communicated via GOOSE messaging.

Enhanced with optional hardware, the IED also features three light detection channels for arc fault protection of the circuit breaker, busbar and cable compartment of metal-enclosed indoor switchgear. Fast tripping increases personnel safety and limits switchgear damage, should an arc fault occur.

A standard configuration can be adjusted using the signal matrix functionality (SMT) or the optional graphical application configuration functionality (ACT) of the Protection and Control IED Manager PCM600. The ACT supports creation of multi-layer logic by combining function blocks along with timers and flip-flops. By combining protection and logic functions the IED can be modified to fit the requirements of the application.

REM615 also integrates functionality for the control of one switching device via the front panel HMI or by remote control.

## Standardized communication

REM615 features genuine support for the new IEC 61850 standard for inter-device substation communication. It also supports the DNP3, the IEC 60870-5-103 protocol and the industry standard Modbus® protocol. For increased communication availability and reliability the IED offers an optional second and third Ethernet network interface.

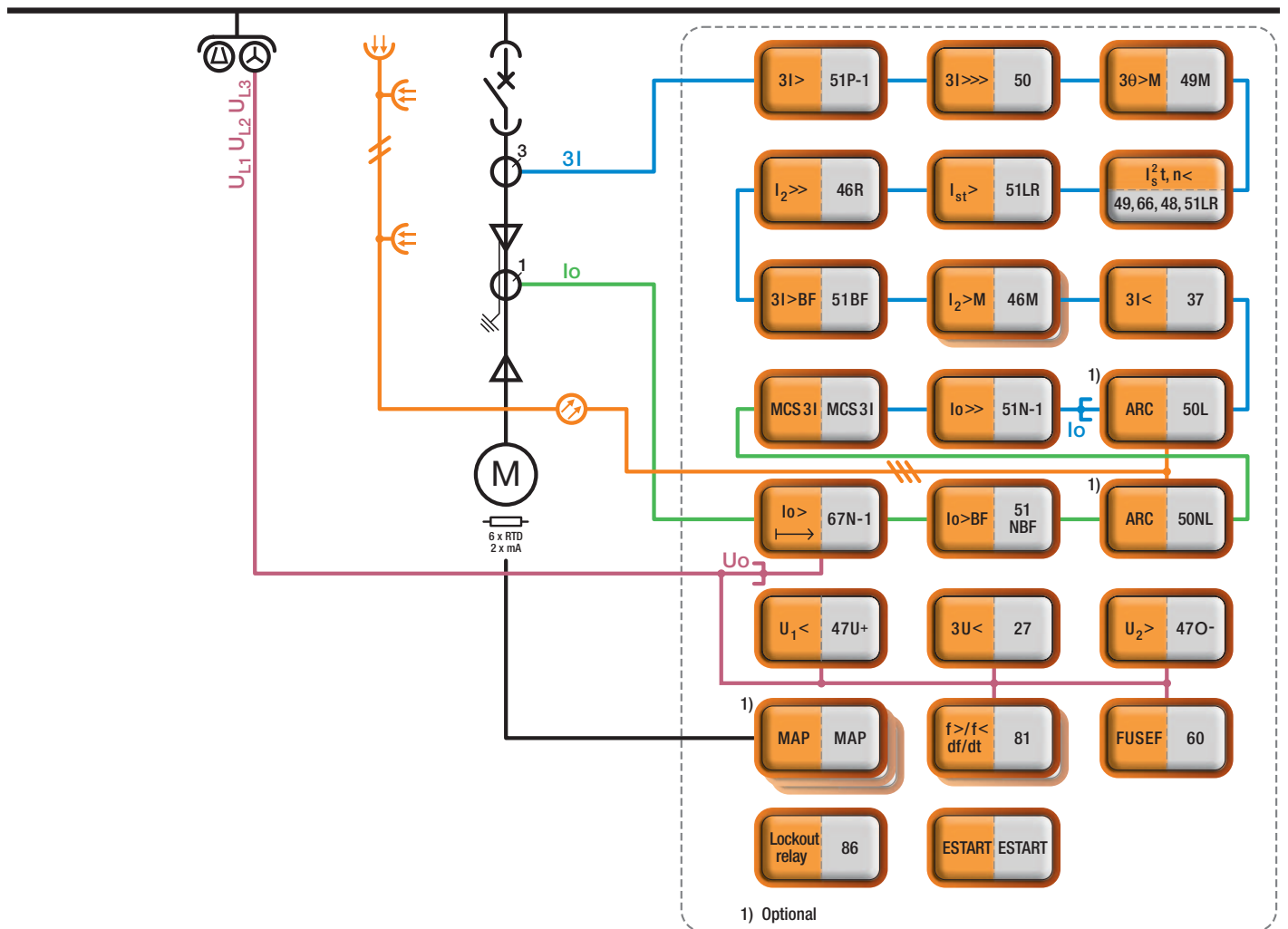

Protection function overview of the B configuration of REM615.

The self-healing Ethernet solution constitutes a cost efficient communication loop controlled by a managed switch. The managed switch controls the consistency of the loop, routes the data and corrects the flow of data in communication disturbance situations. The self-healing Ethernet ring can be built on the Ethernet based IEC 61850, Modbus® and DNP3 protocols.

The implementation of the IEC 61850 standard in REM615 covers both vertical and horizontal communication, including GOOSE messaging with binary and analog signals and parameter setting according to IEC 61850-8-1. For accurate time stamping REM615 supports synchronization over Ethernet using SNTP or over a separate bus using IRIG-B.

### Pre-emptive condition monitoring

For continuous control of its operational availability REM615 features a comprehensive set of monitoring functions including supervise the IED itself, the CB trip circuit, the current circuit, fuses, circuit breaker and motor runtime counting.

### Single line diagram

The 615 series IEDs with large graphical display offer customizable single line mimic diagrams (SLD) with position indication for the switching devices. The IED can also display measured values provided by the chosen standard configuration. The SLD is also available via the web-browser based HMI. The default SLD can be modified according to user needs using the graphical display editor of PCM600.

# Standard configurations

## Standard configurations

Description	Standard configuration
Motor protection, optional RTD/mA inputs	A
Motor protection with current, voltage and frequency based protection and measurement functions, optional RTD/mA inputs	B
Motor protection with current, voltage and frequency based protection and measurement functions	C

• = included  
○ = optional

## Supported functions, codes and symbols

Functionality	IEC 61850	IEC 60617	IEC-ANSI	A	B	C
<b>Protection</b>						
Three-phase non-directional overcurrent protection, low stage, instance 1	PHLPTOC1	3I> (1)	51P-1 (1)	•	•	•
Three-phase non-directional overcurrent protection, instantaneous stage, instance 1	PHIPTOC1	3I>>> (1)	50P/51P (1)	•	•	•
Non-directional earth-fault protection, low stage, instance 1	EFLPTOC1	Io> (1)	51N-1 (1)	• <sup>2)</sup>	-	-
Non-directional earth-fault protection, high stage, instance 1	EFHPTOC1	Io>> (1)	51N-2 (1)	• <sup>2)</sup>	• <sup>3)</sup>	• <sup>3)</sup>
Directional earth-fault protection, low stage, instance 1	DEFLPDEF1	Io> → (1)	67N-1 (1)	-	• <sup>2)5)</sup>	• <sup>2)4)</sup>
Three-phase undervoltage protection, instance 1	PHPTUV1	3U< (1)	27 (1)	-	•	•
Positive-sequence undervoltage protection, instance 1	PSPTUV1	U1< (1)	47U+ (1)	-	•	•
Negative-sequence overvoltage protection, instance 1	NSPTOV1	U2> (1)	47O- (1)	-	•	•
Frequency protection, instance 1	FRPFRQ1	f>/f<, df/dt (1)	81 (1)	-	•	•
Frequency protection, instance 2	FRPFRQ2	f>/f<, df/dt (2)	81 (2)	-	•	•
Negative-sequence overcurrent protection for motors, instance 1	MNSPTOC1	I2>M (1)	46M (1)	•	•	•
Negative-sequence overcurrent protection for motors, instance 2	MNSPTOC2	I2>M (2)	46M (2)	•	•	•
Loss of load supervision	LOFLPTUC1	3I<	37	•	•	•
Motor load jam protection	JAMPTOC1	Ist>	51LR	•	•	•
Motor start-up supervision	STTPMSU1	Is2t n<	49, 66, 48, 51LR	•	•	•
Phase reversal protection	PREVPTOC1	I2>>	46R	•	•	•
Thermal overload protection for motors	MPTR1	3Ith>M	49M	•	•	•
Circuit breaker failure protection	CCBRBRF1	3I>/Io>BF	51BF/51NBF	•	•	•
Master trip, instance 1	TRPPTRC1	Master Trip (1)	94/86 (1)	•	•	•
Master trip, instance 2	TRPPTRC2	Master Trip (2)	94/86 (2)	•	•	•
Arc protection, instance 1	ARCSARC1	ARC (1)	50L/50NL (1)	○	○	○
Arc protection, instance 2	ARCSARC2	ARC (2)	50L/50NL (2)	○	○	○
Arc protection, instance 3	ARCSARC3	ARC (3)	50L/50NL (3)	○	○	○
Multi-purpose protection, instance 1 <sup>1)</sup>	MAPGAPC1	MAP (1)	MAP (1)	○	○	-
Multi-purpose protection, instance 2 <sup>1)</sup>	MAPGAPC2	MAP (2)	MAP (2)	○	○	-
Multi-purpose protection, instance 3 <sup>1)</sup>	MAPGAPC3	MAP (3)	MAP (3)	○	○	-

### Supported functions, codes and symbols

Functionality	IEC 61850	IEC 60617	IEC-ANSI	A	B	C
<b>Control</b>						
Circuit-breaker control	CBXCBR1	I ↔ O CB	I ↔ O CB	•	•	•
Disconnecter position indication, instance 1	DCSXSUI1	I ↔ O DC (1)	I ↔ O DC (1)	•	•	•
Disconnecter position indication, instance 2	DCSXSUI2	I ↔ O DC (2)	I ↔ O DC (2)	•	•	•
Disconnecter position indication, instance 3	DCSXSUI3	I ↔ O DC (3)	I ↔ O DC (3)	•	•	•
Earthing switch indication	ESSXSUI1	I ↔ O ES	I ↔ O ES	•	•	•
Emergency start-up	ESMGAPC1	ESTART	ESTART	•	•	•
<b>Condition Monitoring</b>						
Circuit-breaker condition monitoring	SSCBR1	CBCM	CBCM	•	•	•
Trip circuit supervision, instance 1	TCSSCBR1	TCS (1)	TCM (1)	•	•	•
Trip circuit supervision, instance 2	TCSSCBR2	TCS (2)	TCM (2)	•	•	•
Current circuit supervision	CCRDI1	MCS 3I	MCS 3I	•	•	•
Fuse failure supervision	SEQRUF1	FUSEF	60	-	•	•
Runtime counter for machines and devices	MDSOPT1	OPTS	OPTM	•	•	•
<b>Measurement</b>						
Disturbance recorder	RDRE1	-	-	•	•	•
Three-phase current measurement, instance 1	CMMXU1	3I	3I	•	•	•
Sequence current measurement	CSMSQI1	I1, I2, I0	I1, I2, I0	•	•	•
Residual current measurement, instance 1	RESCMMXU1	I0	I0	•	•	•
Three-phase voltage measurement	VMMXU1	3U	3U	-	•	•
Residual voltage measurement	RESVMMXU1	U0	Vn	-	-	•
Sequence voltage measurement	VSMSQI1	U1, U2, U0	U1, U2, U0	-	•	•
Three-phase power and energy measurement, including power factor	PEMMXU1	P, E	P, E	-	•	•
RTD/mA measurement	XRGGIO130	X130 (RTD)	X130 (RTD)	o	o	-
Frequency measurement	FMMXU1	f	f	-	•	•

<sup>1)</sup> Multi-purpose protection is used for, for example, RTD/mA based protection

<sup>2)</sup> I0 selectable by parameter, I0 measured as default

<sup>3)</sup> I0 selectable by parameter, I0 calculated as default

<sup>4)</sup> U0 selectable by parameter, U0 measured as default

<sup>5)</sup> U0 calculated and negative sequence voltage selectable by parameter, U0 calculated as default

Note that all directional protection functions can also be used in non-directional mode.

The instances of a protection function represent the number of identical function blocks available in a standard configuration.

By setting the application specific parameters of an instance, a protection function stage can be established.

# Contact us

For more information see REM615 Product Guide  
or contact us:

## **ABB Oy, Distribution Automation**

P.O. Box 699

FI-65101 VAASA, Finland

Phone: +358 10 22 11

Fax: +358 10 22 41094

## **ABB Limited, Distribution Automation**

Maneja, Vadodara – 390013, India

Phone: +91 265 260 4386

Fax: +91 265 263 8922

## **ABB Industrial Park**

Torch Hi-tech Industrial Development Zone

Xiamen, Fujian, 361006, P.R.China

Phone: +86 592 570 2288

Fax: +86 592 571 8598

[www.abb.com/substationautomation](http://www.abb.com/substationautomation)