

MicroSCADA

Modernization of the Remote Control System of the Power Utility of Järvi-Suomen Energia Oy

In February 1998, the power utility of Järvi-Suomen Energia Oy, Finland, ordered a new MicroSCADA remote control system and Open++Opera distribution management system for the control and supervision of the power distribution system. The delivery included a redundant control system with communication equipment and software for the control centre in Mikkeli, three workstations to be located in the regional service centre and four workstations to be located in the distribution areas, two distribution management system servers and one ELCOM server. Existing substations are connected to the new system via protocol converters.

Facts about the power utility Järvi-Suomen Energia Oy

Järvi-Suomen Energia Oy is responsible for the power transmission of the Suur-Savon Sähköyhtiöt Group.

Power transmission	1 100
GWh	
Peak power	250 MW
Number of customers	85 000
110 kV transmission network	360 km
20 kV distrib. network (70% in forest)	8 400 km
0.4 kV network	13 800 km
Stations	29
Switching stations in the distrib. netw.	3
Secondary substations	6 600
Remote-controlled disconnecter st.	164
Manually operated disconnectors	3 000
Power stations:	
- hydroelectric power plants	3
- thermal power plants	1
Personnel (SSS Group 250) JSE	27

Main reasons for the modernization:

The power utility has been using a NETCON remote control system since 1987.

Reasons for the procurement:

- the remote control system used could not be enlarged
- system usability and maintainability did not meet the present needs
- lack of modern distribution management software
- the system was not able to utilize modern relay protection technology and fault location calculation
- no connections to other internal and external IT systems
- to secure year 2000 compliance and the future operation of the remote control

Reasons for selecting the MicroSCADA supervision and control system

Features speaking in favour of the MicroSCADA:

- the system is open and provides easy connection to other systems and substations delivered by other suppliers
- the system can be connected to existing substations using the IEC870 protocol
- back-up connections are available through the dial-up telephone network
- the system supports new protection relay technology in supervision and fault location functions
- connections to the company's other IT systems e.g. energy management and planning systems
- workstations located in the distribution areas can be connected via the data communication network of the company
- the system can be easily maintained and updated in the future.

Size of the system

NETCON 8830/8835 RTUs	30
- stations provided with communicating SPACOM relays	
PROCOL RCT400 RTUs	2
Allen-Bradley RTUs	1
NETCON 8810 disconnector RTUs	164
Process pictures	approx. 280
Report database	approx. 400 MB

Project responsibility

ABB	JSE	Task
5 %	95 %	Picture editing
5 %	95 %	Database fill in and testing
10 %	90 %	Installations
95 %	5 %	Commissioning of the system
10 %	90 %	Commissioning of the RTUs
10 %	90 %	Report specifications
95 %	5 %	System specifications

Communication

- Fixed 4-wire connection to the stations
- LAN 100/10 Mb/s
- Radio link
- Radio telephone
- Telephone connections

Communication with the stations using the IEC 870-5-101 protocol, which is converted to the NETCON and SPA protocols in the substations.

Communication with the disconnector stations using the NETCON protocol, which is converted to the IEC 870-5-101 protocol on the NCC level.

100 Mb/s LAN is used on the control centre level.

Special characteristics of the project

- The distribution management system is connected to the network information system, customer information systems and telephone answering system
- IEC 870-5-101/NETCON +SPA protocol converters.

Equipment

MicroSCADA servers:	2 x 400 P2	2, HSB
Workstations:	1 x 400 P2	7
- one workstation also operates as SQL server		
Data communication servers:	2 x 400 P2	4
ELCOM server:	1 x 400 P2	1
DMS server:	1 x 400 P2	2
COM/Vaajakoski	1 x 400 P2	1
Displays:	24" display	3x3+2
	21" display	5
Other equipment	See figure	



P.O.Box 3, FIN-50101 MIKKELI, Finland
Tel.+358-10 21 041, Fax. +358-10 210 4345
<http://www.ssoy.fi>

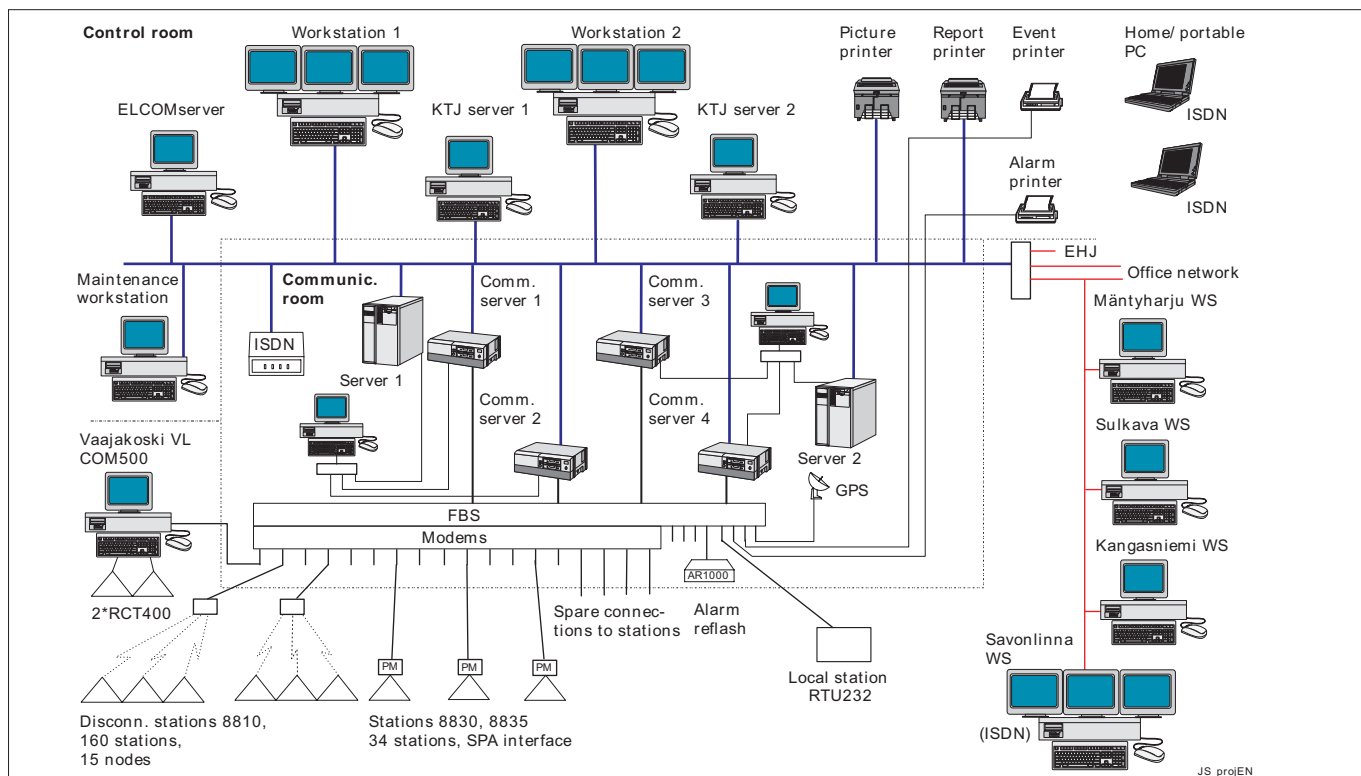

Fig. Remote control system of Järvi-Suomen Energia Oy.

Data subject to change without notice



ABB Substation Automation Oy

P.O. Box 699, FIN-65101 VAASA, Finland
Tel. +358-10 224 000, Fax. +358-10 224 1094, <http://www.abb.fi>