

Technical specification

Model 9C53300R000011M00
MRP code 68881595

Motor parameters

Continuous stall torque	Mo	1	18.4	Nm
Peak stall torque	Mmax	2	55.2	Nm
Rated torque	Mn @ nN	1	12.4	Nm
Rated speed	nN		3000	rpm
Rated frequency	fN		250	Hz
Number of motor poles	p		10	

Winding specifications

Torque constant	KTo_cold	2-3-5	1.69	Nm/A
Voltage constant	KE	2-3-4	0.97	Vs/rad
Resistance between phases [Ω]	R	2-3	0.64	Ohm
Inductance between phases [mH]	L	6	10.0	mH
Continuous current @ Mo	Io	1-5	12.4	A
Current @ Mmax	Imax	2-5	41.3	A
Rated current @ Mn	In	1-5	8.8	A
Bemf between phases @ nN	Ephph	2-3-4	306	V

Mechanical parameters

Moment of inertia of rotor	JM	7	31.6	kg.cm ²
Mass of the motor	M	7	20.0	kg
Protection degree (body only)	-		IP65	

Notes:

- 1) Average motor windings over temperature 100 °C, ambient temperature 40 °C, flange mounted (300x300x20 steel)
- 2) All motor parts at 20 °C
- 3) Tolerance +/-10%
- 4) Vrms between phases
- 5) Arms
- 6) Tolerance +/-15%
- 7) Motor without brake

All values have been calculated

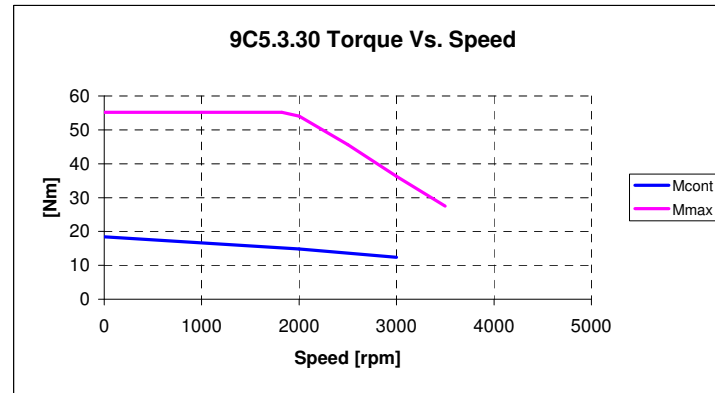

Notes:

DC bus voltage: 565 Vdc (AC 400 V supply)
 Max torque curve may depend on actual DC bus voltage.

Transducer type

2-pole resolver, size 15
 Resolver pole pairs: 1
 Supply voltage: 7 V
 Supply frequency: 10 kHz

Brake parameters

Rated voltage	24	Vdc
Input power	28.0	W
Input current	1.17	A
Braking torque (min. static)	30.0	Nm
Disc inertia	1.82	kg.cm ²
Weight	1.8	kg

Notes:

Parking brake only! Motor shaft must be at standstill when brake is actuated.

Motor overall dimensions on next page

See motor quick guide for additional information on installation, connections and transducers.

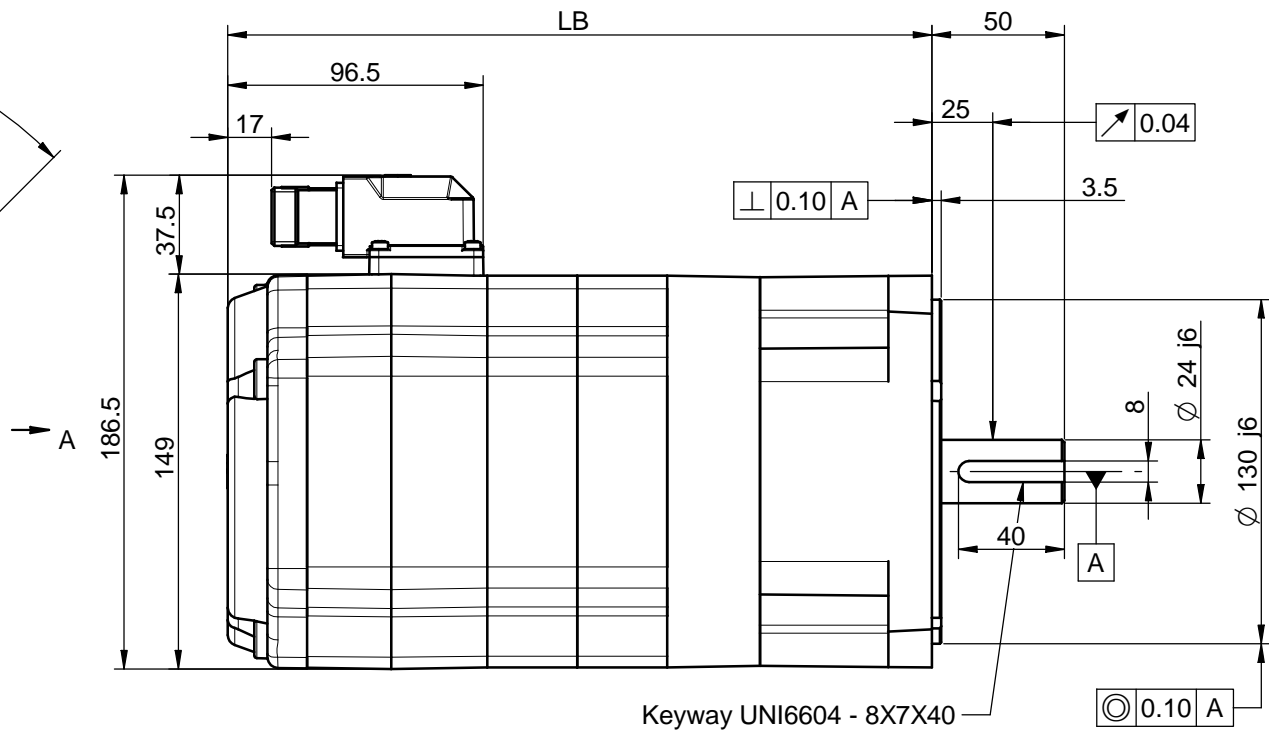
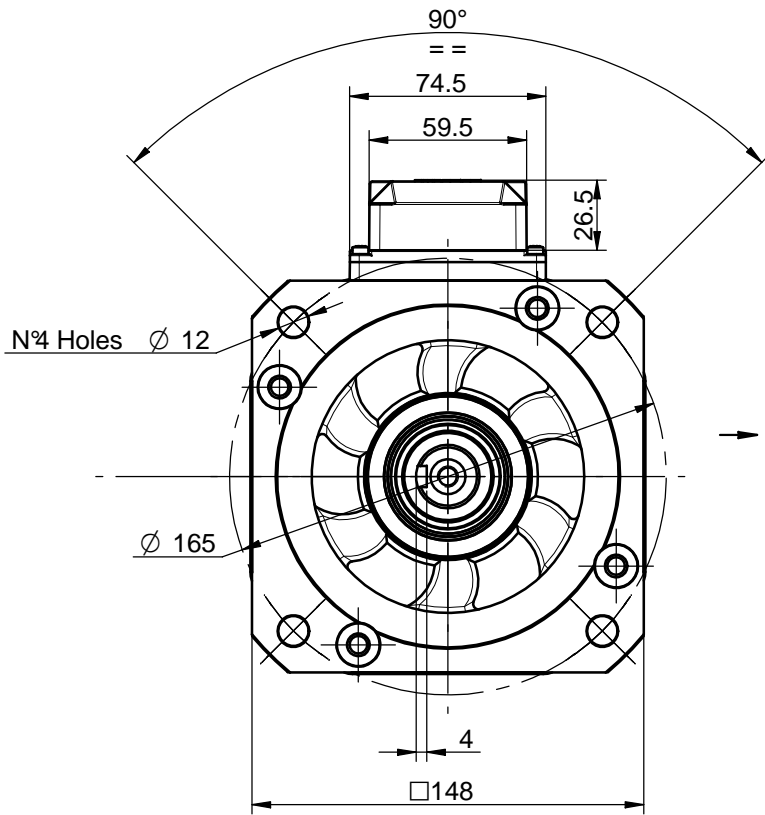

Keyway UNI6604 - 8X7X40

Signal Connector (17 pins) Power Connector (8 pins)

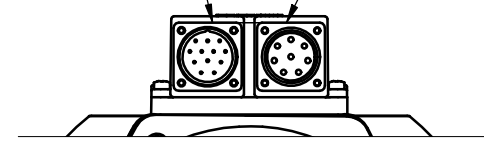

View A

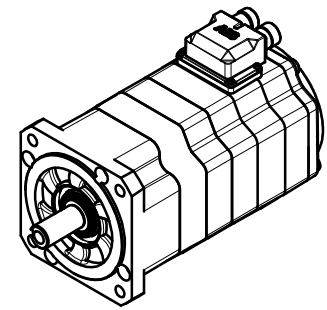

NOTES:

- 1) This drawing refers to 9C5.2 motor equipped with brake and encoder.
- 2) Dimensions may be subject to changes.
- 3) All motors balanced with half-key, full key in package.

Motor Size	LB [mm]
9C5.2	266
9C5.3	300
9C5.4	334
9C5.6	402

(A) - 24/09/08 - Modified dimensions in table, updated drawing
 (B) - 12/11/08 - Removed 32X58 shaft option

<input checked="" type="checkbox"/>	<input checked="" type="checkbox"/>	<input checked="" type="checkbox"/>	<input checked="" type="checkbox"/>	<input checked="" type="checkbox"/>	<input checked="" type="checkbox"/>
C	D	E	F	G	H
I	L	MODIFICHE			

 ABB S.p.A.	QUOTE SENZA INDICAZIONE DI TOLLERANZA GRADO DI PRECISIONE SECONDO UNI 5307-63	<input type="checkbox"/> GROSSOLANO <input type="checkbox"/> MEDIO <input type="checkbox"/> PRECISO		SCALA DATA 1:2 22/10/2007
	DENOMINAZIONE 9C5 Motor Overall Dimensions			LAVORAZIONI 0.2 ✓ = ✓ 0.8 ✓ = ✓ 3.2 ✓ = ✓ 12.5 ✓ = ✓ ✓ = ~
CODICE	MATERIALE		PROTEZ. SUPERFICIALE	PESO
	-			--

ABB S.p.A., proprietaria di questo disegno, ne vieta la comunicazione a terzi e la diffusione non autorizzata