

## Technical specification

**Model** 9C11600R000011M00

**MRP code**

### Motor parameters

Continuous stall torque	Mo	1	1.35	Nm
Peak stall torque	Mmax	2	4.05	Nm
Rated torque	Mn @ nN	1	1.2	Nm
Rated speed	nN		6000	rpm
Rated frequency	fN		500	Hz
Number of motor poles	p		10	

### Winding specifications

Torque constant	KTo_cold	2-3-5	0.72	Nm/A
Voltage constant	KE	2-3-4	0.42	Vs/rad
Resistance between phases [Ω]	R	2-3	13.4	Ohm
Inductance between phases [mH]	L	6	54.0	mH
Continuous current @ Mo	Io	1-5	2.1	A
Current @ Mmax	Imax	2-5	7.1	A
Rated current @ Mn	In	1-5	2.0	A
Bemf between phases @ nN	Ephph	2-3-4	261	V

### Mechanical parameters

Moment of inertia of rotor	JM	7	0.57	kg.cm <sup>2</sup>
Mass of the motor	M	7	3.0	kg
Protection degree (body only)	-		IP65	

#### Notes:

- 1) Average motor windings over temperature 100 °C, ambient temperature 40 °C, flange mounted (300x300x20 steel)
- 2) All motor parts at 20 °C
- 3) Tolerance +/-10%
- 4) Vrms between phases
- 5) Arms
- 6) Tolerance +/-15%
- 7) Motor without brake

All values have been calculated

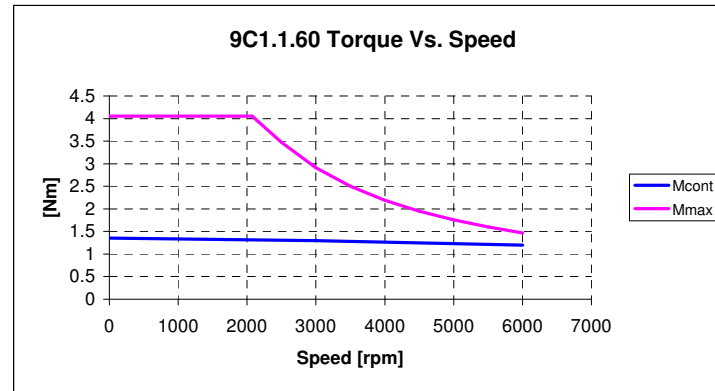

#### Notes:

DC bus voltage: 565 Vdc (AC 400 V supply)  
Max torque curve may depend on actual DC bus voltage.

#### Transducer type

2-pole resolver, size 15  
Resolver pole pairs: 1  
Supply voltage: 7 V  
Supply frequency: 10 kHz

#### Brake parameters

Rated voltage	24	Vdc
Input power	6.3	W
Input current	0.26	A
Braking torque (min. static)	2.5	Nm
Disc inertia	0.10	kg.cm <sup>2</sup>
Weight	0.5	kg

#### Notes:

Parking brake only! Motor shaft must be at standstill when brake is actuated.

Motor overall dimensions on next page

See motor quick guide for additional information on installation, connections and transducers.

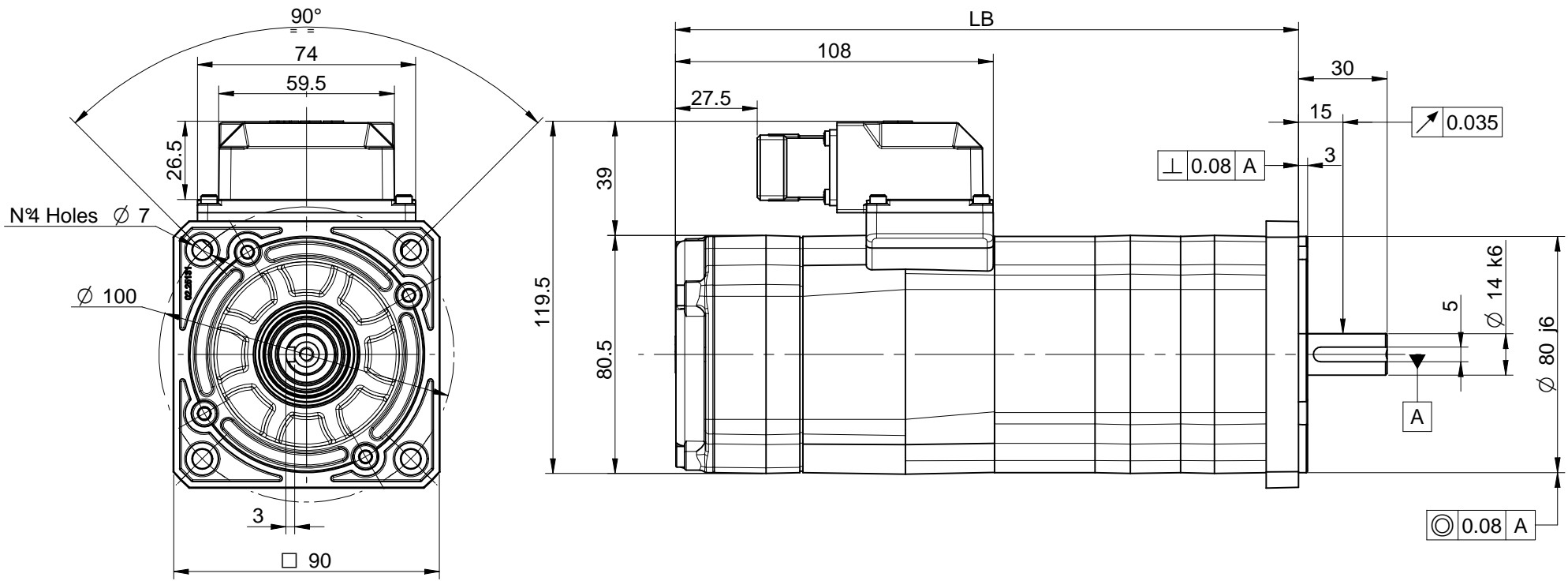

N°4 Holes  $\varnothing$  7

$\varnothing$  100

3

90

LB

108

27.5

39

80.5

30

15

3

0.035

0.08 A

14 k6

5

A

14

$\varnothing$  80 i6

0.08 A

Signal Connector (17 pins)      Power Connector (8 pins)

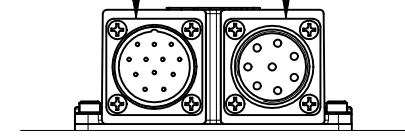

VISTA A

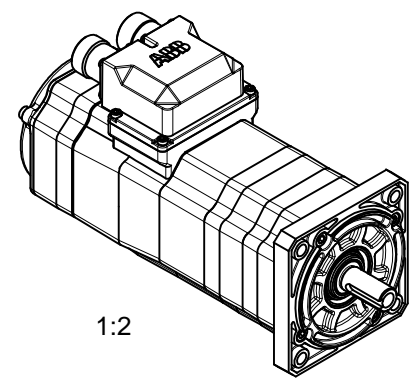

1:2

- NOTES:
- 1) This drawing refers to 9C1.1 motor equipped with brake and encoder.
  - 2) Dimensions may be subject to changes.
  - 3) All motors balanced with half-key, full key in package.

MOTOR SIZES				
	LB RESOLVER (mm)	LB ENCODER (mm)	LB Brake (mm)	LB Brake + ENCODER (mm)
9C1.1	152	181	181	210
9C1.2	186	215	215	244
9C1.3	220	249	249	278
9C1.4	254	283	283	312

	QUOTE SENZA INDICAZIONE DI TOLLERANZA GRADO DI PRECISIONE SECONDO UNI 5207-83	<input type="checkbox"/> GROSSOLANO <input type="checkbox"/> MEDIO <input checked="" type="checkbox"/> PRECISO		SCALA 1:1	DATA 22/10/2007
	<b>9C1 Motor Overall Dimensions</b>	LAVORAZIONI 0.2/√=vvv 0.8/√=vvv 3.2/√=vvv 12.5/√=vvv	DISEGN. PGS Ing. Secondo	CONTROLL. Ing. Secondo	SERIE 9C1
CODICE	File: 15250500 - Ingombro 9C1 - Finland.dft	PROT. SUPERFICIALE	PESO		

A) 2008/07/11 - Modified lengths inside table  
 B) 2009/03/13 - Updated Drawing

XXXX  
 C D E  
 F G H I L  
 MODIFICHE

ABB S.p.A. proprietà di questo disegno, ne vieta la comunicazione a terzi e la diffusione non autorizzata