

# Low Voltage General Purpose Brake Motors

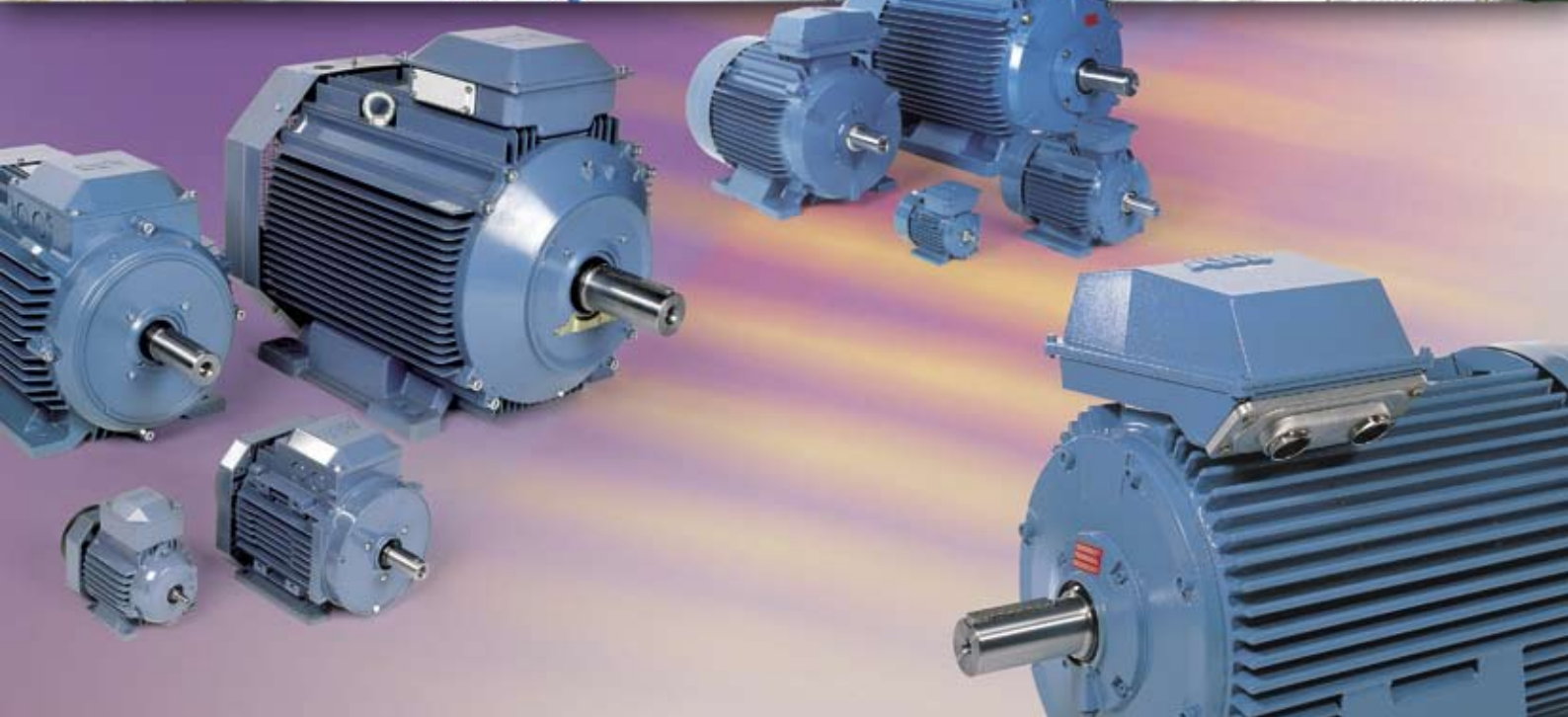

**ABB**

# Making you more competitive

ABB's General purpose motor is designed for use in general industry, meeting the demands of standard applications for OEM's. Motors are readily available from central stock locations and distributors around the world. The motors have high build quality, are available with all the features needed by the OEM market and can be modified to meet most specifications.



*ABB ([www.abb.com](http://www.abb.com)) is a leader in power and automation technologies that enable utility and industry customers to improve performance while lowering environmental impact. The ABB Group of companies operates in around 100 countries and employs about 120,000 people.*

# General Purpose Brake Motors

Totally enclosed squirrel cage three phase low voltage motors,  
Sizes 63 - 180, 0.055 to 22 kW

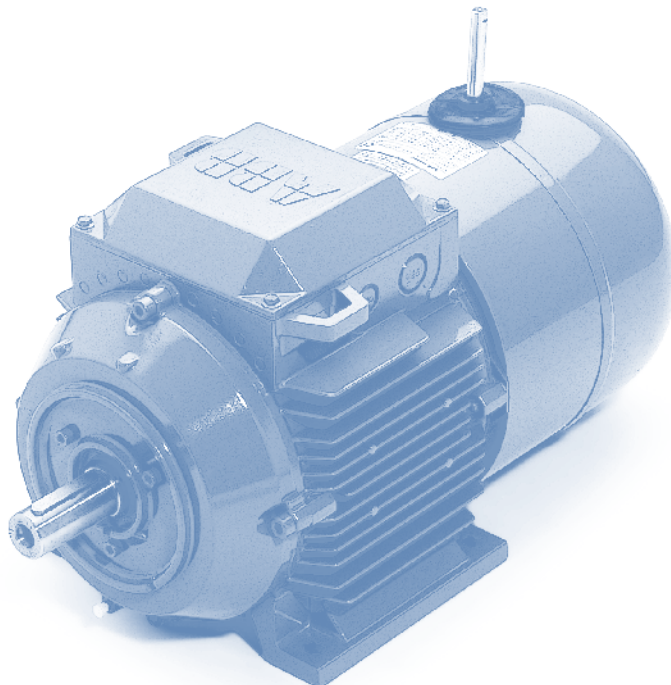

[www.abb.com/motors&generators](http://www.abb.com/motors&generators)

- > Motors
- > Low voltage motors
- > General purpose motors

<b>Mechanical design .....</b>	<b>4</b>
<b>Ordering information.....</b>	<b>11</b>
<b>Technical data.....</b>	<b>12</b>
<b>Variant codes .....</b>	<b>24</b>
<b>Rating plates.....</b>	<b>24</b>
<b>Dimension drawings.....</b>	<b>25</b>
<b>Brake motors in brief .....</b>	<b>27</b>

ABB reserves the right to change the design, technical specification and dimensions without prior notice.

# Mechanical design

## Degrees of protection

The degrees of protection, as per IEC standards 60034-5, are: terminal box and electrical components of the brake – IP 55; other motor parts – IP 55.

Mechanical components of the brake – IP 23 S.

Mechanical parts of the brake, protected with a rubber ring and V-ring – IP 55 (optional: variant code 213).

## Mounting arrangements of brake motors

The design of the brake motor enables it to operate in any mounting position. Nevertheless, the position of the drain holes should be taken into account.

Vertically mounted motors with the shaft end downwards, intended for outdoor operation, should be provided with a protective roof to avoid water ingress and the possibility of ice forming on the brake.

## Operation

ABB's brake motor is a standard motor modified for braking duties, i.e. a three phase induction motor with standard dimensions and output rating.

The electro-magnetic disc brake is powered, by either DC current through a rectifier located in terminal box or three phase AC current.

When the brake coil is de-energised, the brake is actuated by spring pressure.

The axial movement of the brake disc performs a dual

braking action against the moving electromagnet and the motor shield, without pressure or impact being transmitted to the bearings.

The brake linings withstand high temperatures, have great wear resistance and give long life. Because of the very low wear of the braking disc, the brakes of the ABB motor usually require only one-third of the maintenance required by other common brake types in the market.

## Lubrication and bearings

The bearings incorporate two Z-type non-friction sealing plates. The amount of grease is sufficient for the life of the bearing.

The motors are fitted with the bearings listed in the table.

Motor size		D-end	N-end
<b>M3VRF/S 63 A, B, BB</b>		6202-2Z/C3	6202-2Z/C3
	<b>71</b>	6203-2Z/C3	6203-2Z/C3
	<b>80</b>	6204-2Z/C3	6204-2Z/C3
<b>M3ARF/S</b>	<b>90</b>	6205-2Z/C3	6205-2Z/C3
	<b>100</b>	6306-2Z/C3	6206-2Z/C3
	<b>112</b>	6206-2Z/C3	6206-2Z/C3
	<b>132</b>	6208-2Z/C3	6208-2Z/C3
	<b>160</b>	6309-2Z/C3	6209-2Z/C3
	<b>180</b>	6310-2Z/C3	6209-2Z/C3



# Replacing the brake disc

The brake disc must be replaced when reaching the minimum permissible lining thickness stated in Table 1.

# Rectifier

The rectifier is a device for DC brake applications. It is highly resistant to temperature as well as to voltage peaks, and it includes an additional protection of the auxiliary contact of contactor. Its compact design enables it to be placed in the motor terminal box.

# Connection for DC brake

The brake is fed via a rectifier. The voltage stated on the brake rating plate is that of the brake coil on the DC side of the rectifier.

The coil can operate reliably between of 90% and 110% of the rated voltage. For voltages outside these limits, please consult ABB.

## Standard connection (t'21~)

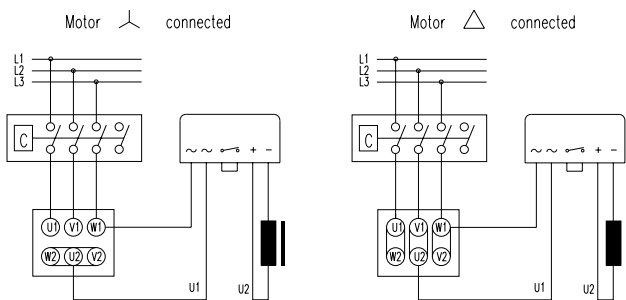

## Reconnection (t21=)

To obtain instant braking, please see table 2 (t21=), use the following diagram.

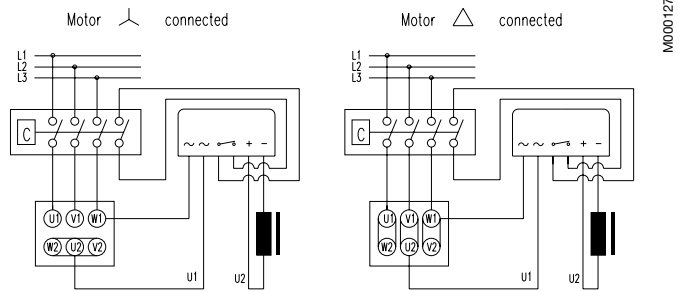

## Reconnection (t21~)

When it is necessary to reduce the braking time, the connections should be modified according to the following diagram. The breaking of the circuit on the AC side is controlled by using an auxiliary contact of the contactor.

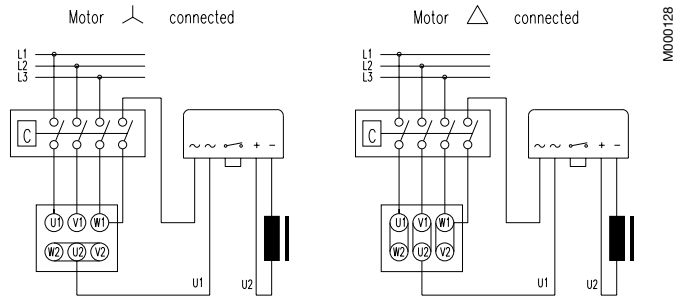

# Connection of AC brake

The coil should only be used between 90% - 110% of its rated voltage.

## Standard connection (t21)

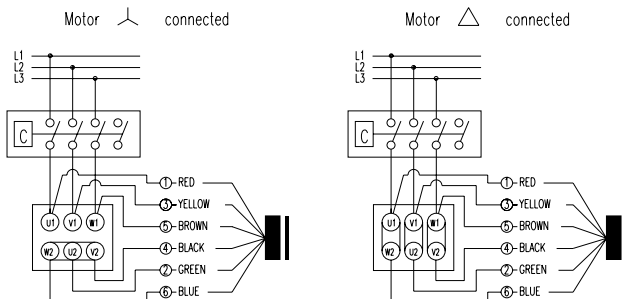

## Reconnection (t21f)

To obtain instant braking, the coil must be fed separately from the motor terminals.

### Remark:

Regardless of whether a DC or AC brake is used, the brake is usually connected to the motor terminals of single-speed motors. It can, however, also be delivered with a separate brake supply (variant code 086). In case of two-speed motors, the brake is always connected separately. Separate brake connection is compulsory when the motor is driven by a frequency converter.

## Hand release

The device is a lever used to override the action of the brake springs for as long as it is applied.

Hand release is included as standard, except for frame size 63, where it is available as option, see variant code 088.

When installing the release lever, please proceed as follows:

Remove the rubber protection, if fitted. Insert the screw (1) with its washer, position the spring (2) and washer (3) and tighten the nut (4) firmly. Fit the other washer and the square-head nut (5); adjust the position of the nut in relation to the moving magnet (Y value) with the central screw (1). When the required value is reached, tighten the inner nut (4) while holding nut (5) fixed.

**Important:** The use of the release lever needs periodic checking of the Y value and the air gap. The air gap should never exceed the maximum values stated in brake data table 1. Failure to check could result in malfunction due to mechanical locking of the armature.

Size	Y
FM 075.5	1
FM 088.6	1
FM 100.6	1
FM 120.6	1
FM 140.6	1.5
FM 155.6	1.5
FM 170.6	1.5
FM 206.6	1.5

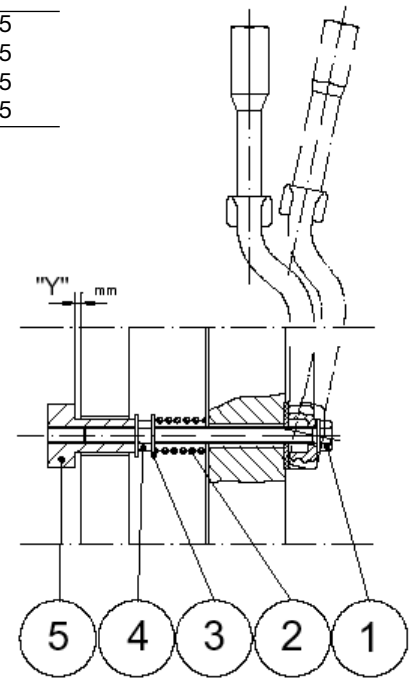

M000130

## Torque adjustment

In brake motors from frame size 71 up to 180, the braking torque can be adjusted from 100% up to 55% of the nominal torque as standard.

Instructions for how to regulate torque are delivered with the brake motor. These instructions describe how to loosen the torque regulation screw (13), as well as the relation between dimension A and torque.

Reduced braking torque, from 60% up to 33%, is available by using variant code 087 (applies for frame sizes 71-180).

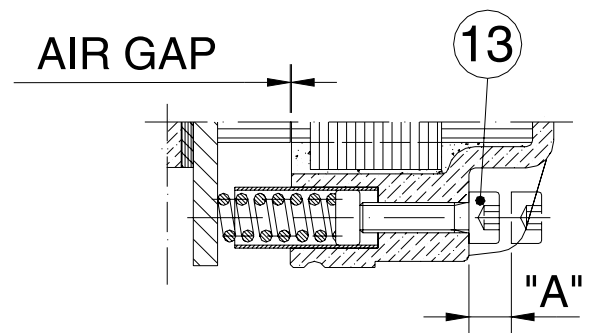

M000131

# Brake operating times

The operating times stated in brake data table 2 are valid for the nominal air gap and warmed-up brake coil.

$t_1$  = Brake release time.

$t_{21}$  = Braking time.

$U_2$  = Rated voltage.

$T_B$  = Nominal braking torque.

Brake release time = the time from when voltage is applied to the brake coil up to the ceasing of braking action.

Braking time = the time from when the current is switched off up to the starting of braking action.

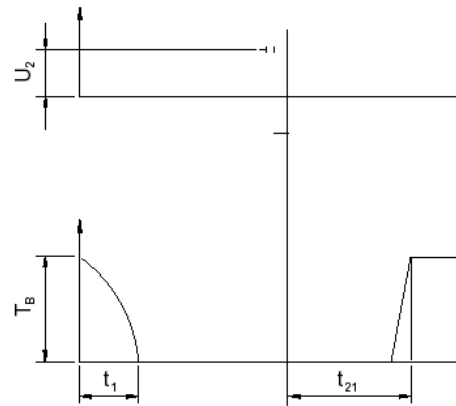

M000132

## Special brakes (with DC brake)

Two-speed motors with one or two windings, motors with 9 or 12 terminals, and motors that have to be started with star-delta connection, with brake coil for DC, are supplied with the rectifier fitted in the motor terminal box, without the two wires that normally connect it to the motor terminal. The AC supply to the rectifier is independent to the motor supply and should be fed by the main contactor.

The standard brake coil connection voltages for 50 and 60 Hz will be those stated in the following table, unless stated otherwise in the order:

<sup>1)</sup> H.W. = Half-wave rectifier, F.W. = Full-wave rectifier

<sup>2)</sup> Special coil on request

<sup>3)</sup> Available using variant code 285

Rectifier input voltage ( $V_{AC}$ )	Rectifier type <sup>1)</sup>	D.C. coil brake voltage (V)
110	F.W.	102 <sup>2)</sup>
220	F.W.	205
230	F.W.	205
240	F.W.	205
250	F.W.	223 <sup>2)</sup>
254	F.W.	223 <sup>2)</sup>
380	H.W.	178
400	H.W.	178
415	H.W.	178
420	H.W.	178
440	H.W.	205
500	H.W.	223 <sup>2)</sup>
24 $V_{DC}$	None	24 <sup>3)</sup>

# Brake data tables

**Table 1.**

Brake motor size		63 A/B	71	80	90	100	112	132	160/180 2 p	4-8 p
Brake type		75.5	88.6	100.6	120.6	140.6	155.6	170.6	206.6	
Rated torque <sup>1)</sup>	$T_{Bnom}$ (Nm)	7.5	10	24	35	44	86	130	200	230
Delivered torque <sup>2)</sup>	$T_{Bdel}$ (Nm)	4	8	21	30	38	72	120	130	200
Nominal air gap	$X$ (mm)	0.2	0.2	0.25	0.35	0.4	0.4	0.4	0.4	
Minimum permissible brake disc thickness	(mm)	3.5	3.5	5	5.5	6	6	7.5	8.5	
Recommended air gap readjustment	$X_n$ (mm)	0.5	0.5	0.6	0.7	0.8	0.8	0.8	0.9	
Thickness of new brake disc	$E_m$ (mm)	5.5	6	7.5	8.5	9.5	9.5	11	13	
Tightening torque: bolt	$C_s$ (Nm)	6	6	12	12	30	30	30	50	
Input coil:										
- AC brake motor	(VA)	60	110	160	250	500	700	990	2000	
- DC brake motor	(W)	30	32	45	72	91	100	120	170	
Friction work per operation	$WR_{max}$ (J)	$1 \times 10^3$	$1.5 \times 10^3$	$2 \times 10^3$	$3.5 \times 10^3$	$6.6 \times 10^3$	$8 \times 10^3$	$1.1 \times 10^4$	$2 \times 10^4$	
Friction work	$PR_{max}$ (J/h)	$3 \times 10^5$	$3.5 \times 10^5$	$4.5 \times 10^5$	$7 \times 10^5$	$9 \times 10^5$	$9.5 \times 10^5$	$1 \times 10^6$	$1.2 \times 10^6$	
Operation for thickness wear of 0.1 mm	$WR_{0.1}$ (J)	$7 \times 10^6$	$10 \times 10^6$	$15 \times 10^6$	$17 \times 10^6$	$31 \times 10^6$	$31.5 \times 10^6$	$48 \times 10^6$	$80 \times 10^6$	
Moment of inertia	$J$ (kgm <sup>2</sup> )	$1.5 \times 10^{-5}$	$3.7 \times 10^{-5}$	$7.5 \times 10^{-5}$	$2 \times 10^{-4}$	$3.7 \times 10^{-4}$	$6.2 \times 10^{-4}$	$10.4 \times 10^{-4}$	$26.4 \times 10^{-4}$	
Weight	(kg)	0.8	1	1.6	2.7	4	5.2	9	16.2	

<sup>1)</sup> Braking torque after performing 10.000-15.000 operations.

<sup>2)</sup> Delivered torque : Torque value marked on rating plate corresponding to the braking torque when the brake motor leaves the ABB factory. Tolerance of +/-10% of this value is accepted. Ambient conditions, temperature on friction surfaces, brake motor positioning and transport applied on the product can affect this value.

In general, all the variables mentioned above can affect the braking torque values, so if an accurate value is needed, ABB recommends it is measured in the real application. This allows adjustment to the required value by using the torque regulation facility.

**Table 2.**

## Braking ( $t_{21}$ ) and release ( $t_1$ ) times

Brake motor sizes		63 A/B	71	80	90	100	112	132	160/180	
Brake type		75.5	88.6	100.6	120.6	140.6	155.6	170.6	206.6	
<b>AC brake coil</b>										
- release time	$t_1$ (ms)	5	6.6	5	5.1	5.5	5	5	5.5	
- standard braking time	$t_{21}$ (ms)	25	25	30	40	50	50	65	105	
- fast braking time	$t_{21f}$ (ms)	10	10	10	10	10	10	10	10	
<b>DC brake coil</b>										
- release time	$t_1$ (ms)	20	20	25	35	40	50	60	100	
- std connection time	$t'_{21}$ (ms)	150	170	210	330	420	720	850	930	
- reconnection time	$t_{21}$ (ms)	30	35	45	70	90	155	190	150	

When fast braking in AC brake is used, the contactor that is operating the coil of the brake has to be over dimensioned taking in consideration a high inductive load.

# Calculations

## Maximum number of connections per hour

The connection frequency that may be achieved with the motors is limited by the temperature rise that they undergo both in the coil and in the rotor. The brakes are designed so that they may withstand the kinds of duty for which these motors are intended.

The maximum number of connections per hour depends on:

- the power  $P_2$  required after reaching the rated speed, i.e. the relative load  $P$  with regard to the rated power  $P_n$ .

$$P = \frac{P_2}{P_n} \times 100 \%$$

- the total inertia  $J$  in  $\text{kgm}^2$  of the mass to be accelerated (inertia of the rotor  $J_m$  as per catalogue, plus the additional inertia  $J_b$  of the driven machine) in relation to the motor shaft, that is,  $J_b$  multiplied by the square of the coefficient of the load speed divided by the motor speed.

$$J = J_m + J_b \times \left[ \frac{n_b}{n_m} \right]^2$$

- the relative duration factor for service S4.

$$S4 = \frac{\text{connection time}}{\text{connection time} + \text{downtime}} \times 100 \text{ in } \%$$

For calculations of the maximum number of connections/hour, please consult ABB.

Required data:

- Type of brake motor
- Load inertia reduced at motor shaft
- Required power  $P_2$
- Type of service

## Options

### Separate brake supply

For brakes which need an independent supply, please note the variant code 086 and the voltage for feeding the brake. When the motor is supplied via a frequency converter, both in the case of DC and AC, the brake should be supplied separately at rated voltage (constant). The separate brake supply can be connected directly, no separate terminal box is needed.

### Dust protection

To protect the brake disc against dust, the brake can be supplied with a rubber protection ring and V-ring.

Variant code 213 should be stated in the order.

## Permitted friction work per operation

Friction work per operation must not exceed the  $WR_{\max}$  values stated in brake data table 1.

$$WR = \frac{1}{2} \times J \left[ \frac{\pi \times n_m}{30} \right]^2 \text{ in joules}$$

## Friction work per hour

The friction work can be calculated if the number of operations per hour is known.

This value must be equal to or less than the  $PR_{\max}$  stated in brake data table 1.

$$PR = WR \times c/h$$

## Braking time

The total braking time from the disconnecting of brake until the machine is stopped is calculated as follows:

$$t = 104.6 \times \frac{J \times n_m}{T_B} + t_{21}$$

$t$  and  $t_{21}$  are in ms

## Maximum number of operations until wear of 0.1 mm

The service life, expressed in switching operations, can be calculated with the aid of the values  $WR_{0.1}$  given in brake data table 1.

$$L_{0.1} = \frac{WR_{0.1}}{WR}$$

## Number of operations before readjusting the air gap

With the  $X_n$  values in table 1 we can calculate the number of required operations until the readjustment of air gap becomes necessary.

$$Ln = \frac{X_n - X}{0.1} \times L_{0.1}$$

## Braking torque reduction

Reduced braking torque range, from 60% up to 33%, is available by using variant code 087.

## Protective roof

To protect motors from accumulation of water, ice or snow when installed outdoors in the vertical position and with the shaft downwards, the assembly should be fitted with a protective roof.

Variant code 005 should in this case be stated in the order.

# Ordering information

When placing an order, please state the following minimum data in the order, as in the example.

The product code of the motor is composed in accordance with the following example.

Motor type	M3ARF 112M
Pole number	4
Mounting arrangement (IM-code)	IM B3 (IM 1001)
Rated output	4 kW
Product code	3GAR112401-ADE
Variant codes if needed	
Brake information	

<b>A</b>	<b>B</b>	<b>C</b>	<b>D,E,F, G</b>	<b>A</b>	Motor type M3VRF/M3ARF (DC brake) M3VRS/M3ARS (AC brake)	
<b>M3ARF</b>	<b>112 M</b>	<b>3GAR 112 401</b>	<b>- ADE, 088 etc.</b>	<b>B</b>	Motor size	
		1 - 4	5 - 6 7	8 - 10	<b>C</b>	Product code
			11	12	<b>D</b>	Mounting arrangement code
			13	14	<b>E</b>	Voltage/frequency code
					<b>F</b>	Generation code
					<b>G</b>	Variant code

## Explanation of the product code:

### Positions 1 to 4

**3GAA** = Totally enclosed motor, aluminum frame

**3GVA** = Totally enclosed motor, aluminum frame, alternative design

### Position 4

R = Brake motor

### Positions 5 and 6

#### IEC-size

**06** = 63                      **12** = 112

**07** = 71                      **13** = 132

**08** = 80                      **16** = 160

**09** = 90                      **18** = 180

**10** = 100

### Position 7

#### Speed (Pole pairs)

**1** = 2 poles                  **6** = 12 poles

**2** = 4 poles                  **7** = > 12 poles

**3** = 6 poles                  **8** = Two-speed motors

**4** = 8 poles                  **9** = Multi-speed motors

**5** = 10 poles

### Position 8 to 10

Serial number

### Position 11

- (dash)

### Position 12

### Mounting arrangement

**A** = Foot-mounted.

**B** = Flange-mounted. Large aluminum flange with clearance holes, sizes 63-100 and 180.

**C** = Flange-mounted. Small aluminum flange with tapped holes, sizes 63-100.

**E** = Flange-mounted. Large cast iron flange with clearance holes, sizes 112-160.

**H** = Foot- and flange-mounted. Large aluminum flange with clearance holes, sizes 63-100 and 180.

**J** = Foot- and flange-mounted. Small aluminum flange with tapped holes, sizes 63-100.

**K** = Foot- and flange-mounted. Large cast iron flange with clearance holes, sizes 112-160.

**N** = Flange mounted. Two piece cast iron flange (IEC-1) with clearance holes, sizes 90-132.

**P** = Foot- and flange-mounted. Two piece cast iron flange (IEC) with clearance holes, sizes 90-132.

### Position 13

#### Voltage and frequency code

See table below

### Position 14

Generation code = **C** (size 63), **E** (sizes 71-180)

**The product code must be, if needed, followed by variant codes.**

# General purpose brake motors

## Technical data for single-speed DC brake motors

IP 55 – IC 411 – Insulation class F, temperature rise class B – Brake IP 23 S

Output kW	Motor type	Product code	Speed r/min	Torque			Efficiency		Power factor cos φ	Current			Moment of inertia J=1/4GD <sup>2</sup> kgm <sup>2</sup>	Weight foot mounted kg	
				rated TN Nm	braking TB Nm	TS/ TN	K <sup>1)</sup>	100%		75%	IN A	IS/IN			c/h <sup>2)</sup>
<b>3000 r/min = 2 pole</b>			<b>400 V 50 Hz</b>						<b>Basic design</b>						
0.18	M3VRF 63 A	3GVR 061 401-••C	2820	0.62	7.5	3.5	12.5	73.7	70.6	0.64	0.56	4.2	3500	0.00023	4.9
0.25	M3VRF 63 B	3GVR 061 402-••C	2810	0.87	7.5	3.6	8.33	77.5	75.8	0.71	0.66	4.5	3500	0.00026	5.4
0.37	M3VRF 71 A	3GVR 071 401-••E	2840	1.25	10	3.8	7.6	77.1	76.5	0.72	1	5.5	2600	0.00051	7
0.55	M3VRF 71 B	3GVR 071 402-••E	2830	1.86	10	3.6	5.26	79.2	78.2	0.76	1.35	5.7	2600	0.0006	8
0.75	M3VRF 80 A	3GVR 081 401-••E	2870	2.49	24	2.9	9.6	81.2	79.3	0.75	1.8	6.2	2000	0.00074	11
1.1	M3VRF 80 B	3GVR 081 402-••E	2850	3.69	24	2.3	6.48	81.4	79.5	0.78	2.5	6.1	2000	0.00078	12
1.5	M3ARF 90 S	3GAR 091 401-••E	2870	5	35	2.4	7	80.1	76.2	0.82	3.35	5.5	1300	0.0021	19
2.2	M3ARF 90 L	3GAR 091 402-••E	2880	7.5	35	2.7	4.7	83.6	83.9	0.87	4.37	7.0	1200	0.0026	22
3	M3ARF 100 L	3GAR 101 401-••E	2900	10	44	2.7	4.4	86.0	84.1	0.88	5.95	7.5	1000	0.00453	32
4	M3ARF 112 M	3GAR 111 401-••E	2850	13.4	86	2.8	6.41	86.0	86.2	0.91	7.4	7.5	500	0.01078	38
5.5	M3ARF 132 SA	3GAR 131 401-••E	2855	18.4	130	3.2	7.06	86.0	86.6	0.88	10.5	7.8	600	0.01657	57
7.5	M3ARF 132 SB	3GAR 131 402-••E	2860	25.1	130	3.4	5.17	88.0	86.2	0.89	13.9	8.5	500	0.01857	62
11	M3ARF 160 MA	3GAR 161 411-••E	2915	36	200	2.1	5.55	88.4	88.0	0.88	20.5	6.1	200	0.05096	124
15	M3ARF 160 M	3GAR 161 412-••E	2900	49	200	2.3	4.1	89.4	89.7	0.90	27	6.0	200	0.05596	134
18.5	M3ARF 160 L	3GAR 161 413-••E	2915	60	200	2.5	3.3	90.4	90.7	0.91	32.5	6.7	200	0.06396	139
22	M3ARF 180 M	3GAR 181 411-••E	2925	72	200	3.0	2.8	91.5	91.7	0.89	39	8.0	120	0.06264	158
<b>3000 r/min = 2 pole</b>			<b>400 V 50 Hz</b>						<b>High-output design</b>						
0.37	M3VRF 63 BB	3GVR 061 403-••C	2800	1.29	7.5	2.3	5.76	73.6	73.1	0.81	0.9	3.5	3500	0.00027	5.9
0.68	M3VRF 71 BB	3GVR 071 403-••E	2800	2.33	10	3.2	4.34	78.9	77.4	0.82	1.59	5.2	2400	0.0006	8
0.75	M3VRF 71 BC	3GVR 071 404-••E	2800	2.57	10	3.1	3.84	78.5	77.9	0.85	1.7	5.1	2400	0.0006	8
1.5	M3VRF 80 C	3GVR 081 403-••E	2840	5.13	24	2.8	4.7	82.4	82.2	0.83	3.16	5.5	1800	0.00111	13
2.7	<sup>3)</sup> M3ARF 90 LB	3GAR 091 403-••E	2860	9	35	2.6	3.88	80.7	83.5	0.86	5.7	7.0	1200	0.0029	24
4	<sup>3)</sup> M3ARF 100 LB	3GAR 101 402-••E	2900	13	44	2.7	3.38	85.0	84.3	0.86	8.1	7.5	1000	0.00543	36
5.5	<sup>3)</sup> M3ARF 112 MB	3GAR 111 402-••E	2855	18.4	86	2.7	4.67	86.5	87.1	0.93	9.9	7.3	500	0.01273	66
9.2	<sup>3)</sup> M3ARF 132 SBB	3GAR 131 404-••E	2825	31.1	130	3.2	4.18	86.0	88.2	0.93	16.6	7.3	500	0.02457	77
11	<sup>3)</sup> M3ARF 132 SC	3GAR 131 403-••E	2835	37	130	3.2	3.51	87.0	87.4	0.93	19.6	8.0	500	0.02383	77
22	<sup>3)</sup> M3ARF 160 LB	3GAR 161 404-••E	2920	72	200	2.6	2.77	92.1	93.0	0.91	38	7.1	200	0.06896	145

<sup>1)</sup> Braking-torque ratio    <sup>2)</sup> No-load (shaft-free) operations/hour    <sup>3)</sup> Temperature rise class F.

The bullets in the product code indicate choice of mounting arrangement and voltage and frequency code, see below and ordering information page.

### Code letters for supplementing product code for mounting arrangement:

Foot-mounted	<b>A</b>
Flange-mounted, 1 flange	<b>B</b> for frame sizes 63-100, 180; <b>E</b> for frame sizes 112-160.
Flange-mounted, 2 flanges	<b>N</b> for frame sizes 90-132
Flange-mounted, small flange	<b>C</b> for frame sizes 63-100

### Code letters for supplementing product code for voltage and frequency (pos 13):

Motor size	<b>S</b> Motor		Brake (input rectifier voltage/brake voltage)	<b>D</b> Motor		Brake (input rectifier voltage/brake voltage)	<b>X</b>
	50 Hz	60 Hz		50 Hz	60 Hz		
<b>63-132</b>	220-240 VΔ 380-420 VY	250-280 VΔ	220-240 V/205 V d.c.	380-420 VΔ 660-690 VY	440-480 VΔ –	380-420 V/178 V d.c.	Any other rated voltage or frequency, 690 V mainum connection for motor and 500 V for brake (input rectifier)
<b>160-180</b>	230 VΔ 400 VY	265 VΔ	230 V/205 V d.c.	400 VΔ 690 VY	460 VΔ –	400 V/178 V d.c.	
Motor size	<b>E</b> Motor		Brake (input rectifier voltage/brake voltage)	<b>F</b> Motor		Brake (input rectifier voltage/brake voltage)	
50 Hz				50 Hz			
<b>63-80</b>	–		–	500 VY		500 V/223 V d.c.	
<b>90-180</b>	500 VΔ		500 V/223 V d.c.	500 VY		500 V/223 V d.c.	

# General purpose brake motors

## Technical data for single-speed DC brake motors

IP 55 – IC 411 – Insulation class F, temperature rise class B – Brake IP 23 S

Output kW	Motor type	Product code	Speed r/min	Torque			Efficiency		Power factor cos φ	Current			Moment of inertia J=1/4GD <sup>2</sup> kgm <sup>2</sup>	Weight foot mounted kg	
				rated TN Nm	braking TB Nm	TS/ TN	K <sup>1)</sup>	100%		75%	IN A	IS/IN			c/h <sup>2)</sup>
<b>1500 r/min = 4 poles</b>			<b>400 V 50 Hz</b>						<b>Basic design</b>						
0.12	M3VRF 63 A	3GVR 062 401-••C	1400	0.82	7.5	2.6	9.37	63.7	58.4	0.59	0.46	3.1	7100	0.00029	5
0.18	M3VRF 63 B	3GVR 062 402-••C	1380	1.25	7.5	2.5	5.76	65.6	62.1	0.64	0.63	3.1	7100	0.00036	5.5
0.25	M3VRF 71 A	3GVR 072 401-••E	1410	1.71	10	2.7	5.88	70.4	69.1	0.71	0.74	4.3	6500	0.00081	7
0.37	M3VRF 71 B	3GVR 072 402-••E	1420	2.51	10	2.6	4	74.6	72.1	0.69	1.05	4.4	6500	0.00104	8
0.55	M3VRF 80 A	3GVR 082 401-••E	1390	3.75	24	2.6	6.31	75.3	73.1	0.76	1.4	4.6	5000	0.00128	11
0.75	M3VRF 80 B	3GVR 082 402-••E	1410	5.08	24	3.5	4.7	78.2	75.6	0.74	1.9	4.7	5000	0.00159	12
1.1	M3ARF 90 S	3GAR 092 401-••E	1410	7.5	35	2.2	4.66	77.5	76.4	0.81	2.59	5.0	3200	0.0034	19
1.5	M3ARF 90 L	3GAR 092 402-••E	1420	10	35	2.4	3.5	80.3	78.1	0.79	3.45	5.0	3200	0.0045	22
2.2	M3ARF 100 LA	3GAR 102 401-••E	1430	15	44	2.4	2.93	83	82.7	0.81	4.8	5.5	2700	0.00733	32
3	M3ARF 100 LB	3GAR 102 402-••E	1430	20	44	2.5	2.2	85	83.9	0.81	6.48	5.5	2700	0.00863	35
4	M3ARF 112 M	3GAR 112 401-••E	1435	26.6	86	2.9	3.23	84.5	83.9	0.80	8.6	7.0	2500	0.01578	40
5.5	M3ARF 132 S	3GAR 132 401-••E	1450	36.2	130	2.2	3.59	87	87.7	0.83	11.1	7.3	1800	0.03357	60
7.5	M3ARF 132 M	3GAR 132 402-••E	1450	49.4	130	2.5	2.63	88	88.6	0.83	14.8	7.9	1400	0.04057	68
11	M3ARF 160 M	3GAR 162 411-••E	1465	72	230	2.4	3.2	88.4	88.8	0.78	22.5	6.9	500	0.07696	117
15	M3ARF 160 L	3GAR 162 412-••E	1460	98	230	2.8	2.3	90	90.5	0.82	29	7.2	500	0.08796	129
18.5	M3ARF 180 M	3GAR 182 411-••E	1455	121	230	2.6	1.9	90.4	90.4	0.84	35	7.0	360	0.10464	161
22	M3ARF 180 L	3GAR 182 412-••E	1460	144	230	3	1.6	91.1	91.5	0.82	42	8.0	360	0.12964	175
<b>1500 r/min = 4 poles</b>			<b>400 V 50 Hz</b>						<b>High-output design</b>						
0.25	M3VRF 63 BB	3GVR 062 403-••C	1370	1.75	7.5	2.5	4.16	70.3	67.4	0.67	0.78	3.2	7100	0.0004	6
0.45	M3VRF 71 BB	3GVR 072 403-••E	1390	3.11	10	2.1	3.22	75.5	75.3	0.76	1.15	4.1	6500	0.00104	8
0.55	M3VRF 71 C	3GVR 072 404-••E	1410	3.74	10	2.7	2.7	77.3	76.9	0.73	1.45	4.8	6500	0.00125	9
0.95	M3VRF 80 C	3GVR 082 403-••E	1410	6.44	24	2.9	3.75	78.9	77.9	0.75	2.35	4.3	500	0.00197	13
1.85	M3ARF 90 L	3GAR 092 403-••E	1390	13	35	2.2	2.69	79.5	78.1	0.80	4.4	4.5	3200	0.0045	22
2.2	M3ARF 90 LB	3GAR 092 404-••E	1390	15	35	2.2	2.33	80.3	81.0	0.83	4.85	4.5	3200	0.0048	23
4	M3ARF 100 LC	3GAR 102 403-••E	1420	27	44	2.5	1.62	81	81.7	0.82	8.65	5.5	2700	0.009	36
5.5	M3ARF 112 MB	3GAR 112 402-••E	1425	36.9	86	2.8	2.33	84.5	83.5	0.83	11.4	7.1	2500	0.018	47
9.2	M3ARF 132 MBA	3GAR 132 404-••E	1450	60	130	2	2.14	88	88.6	0.85	17.8	7.3	1400	0.05	83
11	M3ARF 132 MB	3GAR 132 403-••E	1450	72	130	2.5	1.79	88	89.4	0.86	21	8.3	500	0.05	83
18.5	M3ARF 160 LB	3GAR 162 403-••E	1450	122	230	2.9	1.88	90.5	88.9	0.84	36	6.9	500	0.107	143

<sup>1)</sup> Braking-torque ratio    <sup>2)</sup> No-load (shaft-free) operations/hour    <sup>3)</sup> Temperature rise class F.

The bullets in the product code indicate choice of mounting arrangement and voltage and frequency code, see below and ordering information page.

### Code letters for supplementing product code for mounting arrangement:

Foot-mounted	<b>A</b>
Flange-mounted, 1 flange	<b>B</b> for frame sizes 63-100, 180; <b>E</b> for frame sizes 112-160.
Flange-mounted, 2 flanges	<b>N</b> for frame sizes 90-132
Flange-mounted, small flange	<b>C</b> for frame sizes 63-100

### Code letters for supplementing product code for voltage and frequency (pos 13):

Motor size	<b>S</b> Motor		Brake (input rectifier voltage/brake voltage)	<b>D</b> Motor		Brake (input rectifier voltage/brake voltage)	<b>X</b>
	50 Hz	60 Hz		50 Hz	60 Hz		
<b>63-132</b>	220-240 VΔ 380-420 VY	250-280 VΔ	220-240 V/205 V d.c.	380-420 VΔ 660-690 VY	440-480 VΔ –	380-420 V/178 V d.c.	Any other rated voltage or frequency, 690 V main connection for motor and 500 V for brake (input rectifier)
<b>160-180</b>	230 VΔ 400 VY	265 VΔ	230 V/205 V d.c.	400 VΔ 690 VY	460 VΔ –	400 V/178 V d.c.	
Motor size	<b>E</b> Motor		Brake (input rectifier voltage/brake voltage)	<b>F</b> Motor		Brake (input rectifier voltage/brake voltage)	
	50 Hz			50 Hz			
<b>63-80</b>	–	–	–	500 VY	–	500 V/223 V d.c.	
<b>90-180</b>	500 VΔ	–	500 V/223 V d.c.	500 VY	–	500 V/223 V d.c.	

# General purpose brake motors

## Technical data for single-speed DC brake motors

### IP 55 – IC 411 – Insulation class F, temperature rise class B – Brake IP 23 S

Output kW	Motor type	Product code	Speed r/min	Torque			K <sup>1)</sup>	Efficiency		Power factor cos φ	Current			Moment of inertia J=1/4GD <sup>2</sup> kgm <sup>2</sup>	Weight foot mounted kg
				rated TN Nm	braking TB Nm	TS/ TN		100%	75%		IN A	IS/IN	c/h <sup>2)</sup>		
<b>1000 r/min = 6 poles</b>			<b>400 V 50 Hz</b>					<b>Basic design</b>							
0.09	M3VRF 63 A	3GVR 063 401-••C	910	0.95	7.5	2.1	7.89	47.1	42.5	0.56	0.51	2.1	7700	0.0003	5
0.12	M3VRF 63 B	3GVR 063 402-••C	860	1.27	7.5	1.8	5.9	56.0	53.5	0.55	0.56	2.4	7700	0.00037	5.5
0.18	M3VRF 71 A	3GVR 073 401-••E	920	1.88	10	2.1	5.31	61.1	57.7	0.69	0.64	2.9	7500	0.00078	7
0.25	M3VRF 71 B	3GVR 073 402-••E	920	2.61	10	2.5	3.84	64.9	62.3	0.65	0.86	3.2	7500	0.00096	8
0.37	M3VRF 80 A	3GVR 083 401-••E	925	3.82	24	3.1	6.28	72.9	70.8	0.72	1.04	3.8	7000	0.00186	11
0.55	M3VRF 80 B	3GVR 083 402-••E	925	5.68	24	2.9	4.22	73.3	71.9	0.71	1.55	3.4	7000	0.0022	12
0.75	M3ARF 90 S	3GAR 093 401-••E	930	7.5	35	1.9	4.66	71.5	70.7	0.67	2.36	4.0	3800	0.0034	19
1.1	M3ARF 90 L	3GAR 093 402-••E	930	11	35	2.1	3.18	74.4	72.5	0.69	3.25	4.0	3900	0.0045	22
1.5	M3ARF 100 L	3GAR 103 401-••E	950	15	44	1.9	2.93	80.0	77.0	0.71	3.92	4.5	3300	0.0086	34
2.2	M3ARF 112 M	3GAR 113 401-••E	940	22.3	86	2.1	3.85	80.5	79.3	0.74	5.4	5.6	3200	0.015	40
3	M3ARF 132 S	3GAR 133 401-••E	960	29.8	130	2.0	4.36	84.5	82.7	0.75	6.9	6.1	2400	0.033	59
4	M3ARF 132 MA	3GAR 133 402-••E	960	39.7	130	2.0	3.27	85.5	83.1	0.78	8.7	7.1	1900	0.04	66
5.5	M3ARF 132 MB	3GAR 133 403-••E	955	55	130	2.2	2.36	86.0	85.0	0.78	11.9	6.9	1900	0.047	74
7.5	M3ARF 160 M	3GAR 163 401-••E	970	74	230	2.0	3.14	89.3	88.4	0.79	15.4	6.7	600	0.087	129
11	M3ARF 160 L	3GAR 163 402-••E	970	109	230	2.2	2.13	89.8	88.5	0.78	23	7.1	600	0.127	149
<b>1000 r/min = 6 poles</b>			<b>400 V 50 Hz</b>					<b>High-output design</b>							
0.15	M3VRF 63 BB	3GVR 063 403-••C	900	1.61	7.5	2.2	4.68	56.9	52.1	0.54	0.74	2.2	7700	0.00042	6
0.32	M3VRF 71 C	3GVR 073 403-••E	920	3.33	10	2.6	3.1	64.8	61.6	0.63	1.15	3.2	7500	0.00125	9
1.3	<sup>3)</sup> M3ARF 90 LB	3GAR 093 403-••E	910	13.5	35	1.9	2.59	69.0	69.0	0.71	3.85	4.0	3800	0.005	24
2.2	<sup>3)</sup> M3ARF 100 LC	3GAR 103 402-••E	940	22	44	1.9	2	77.0	72.8	0.71	5.9	4.5	3300	0.009	37
3	<sup>3)</sup> M3ARF 112 MB	3GAR 113 402-••E	935	30.6	86	2.0	2.81	80.0	79.9	0.76	7.2	5.5	3200	0.018	46
6.5	<sup>3)</sup> M3ARF 132 MC	3GAR 133 404-••E	960	64	130	2.0	2.01	85.0	84.5	0.75	14.8	6.6	2400	0.051	79
14	<sup>3)</sup> M3ARF 160 LB	3GAR 163 403-••E	960	139	230	2.7	1.65	89.1	84.5	0.77	29.5	7.6	1900	0.147	164

<sup>1)</sup> Braking-torque ratio

<sup>2)</sup> No-load (shaft-free) operations/hour

<sup>3)</sup> Temperature rise class F.

The bullets in the product code indicate choice of mounting arrangement and voltage and frequency code, see below and ordering information page.

#### Code letters for supplementing product code for mounting arrangement:

Foot-mounted	<b>A</b>
Flange-mounted, 1 flange	<b>B</b> for frame sizes 63-100, 180; <b>E</b> for frame sizes 112-160.
Flange-mounted, 2 flanges	<b>N</b> for frame sizes 90-132
Flange-mounted, small flange	<b>C</b> for frame sizes 63-100

#### Code letters for supplementing product code for voltage and frequency (pos 13):

Motor size	<b>S</b> Motor			<b>D</b> Motor			<b>X</b>
	50 Hz	60 Hz	Brake (input rectifier voltage/brake voltage)	50 Hz	60 Hz	Brake (input rectifier voltage/brake voltage)	
<b>63-132</b>	220-240 VΔ 380-420 VY	250-280 VΔ	220-240 V/205 V d.c.	380-420 VΔ 660-690 VY	440-480 VΔ	380-420 V/178 V d.c.	Any other rated voltage or frequency, 690 V main connection for motor and 500 V for brake (input rectifier)
<b>160-180</b>	230 VΔ 400 VY	265 VΔ	230 V/205 V d.c.	400 VΔ 690 VY	460 VΔ	400 V/178 V d.c.	
Motor size	<b>E</b> Motor			<b>F</b> Motor			
	50 Hz		Brake (input rectifier voltage/brake voltage)	50 Hz		Brake (input rectifier voltage/brake voltage)	
<b>63-80</b>	–	–	–	500 VY	–	500 V/223 V d.c.	
<b>90-180</b>	500 VΔ	–	500 V/223 V d.c.	500 VY	–	500 V/223 V d.c.	

# General purpose brake motors

## Technical data for single-speed DC brake motors

IP 55 – IC 411 – Insulation class F, temperature rise class B – Brake IP 23 S

Output kW	Motor type	Product code	Speed r/min	Torque			K <sup>1)</sup>	Efficiency		Power factor cos φ	Current			Moment of inertia J=1/4GD <sup>2</sup> kgm <sup>2</sup>	Weight foot mounted kg
				rated	braking	TS/TN		100%	75%		IN A	IS/IN	c/h <sup>2)</sup>		
<b>750 r/min = 8 poles</b>				<b>400 V 50 Hz</b>				<b>Basic design</b>							
0.055	M3VRF 63 B	3GVR 064 401-••C	680	0.78	7.5	2.1	9.4	38.3	31.8	0.48	0.45	1.8	7700	0.00037	5.5
0.09	M3VRF 71 A	3GVR 074 401-••E	690	1.25	10	2.3	7.69	45.8	37.5	0.57	0.52	2.2	7500	0.00078	7
0.12	M3VRF 71 B	3GVR 074 402-••E	690	1.67	10	2.5	5.88	46.4	38.1	0.55	0.69	2.2	7500	0.00096	8
0.18	M3VRF 80 A	3GVR 084 401-••E	700	2.46	24	3.2	9.6	59.9	54.5	0.60	0.75	3.1	7500	0.0022	11
0.25	M3VRF 80 B	3GVR 084 402-••E	700	3.52	24	2.9	6.85	70.7	67.4	0.62	0.85	3.1	7500	0.00245	12
0.37	M3ARF 90 S	3GAR 094 401-••E	700	5	35	1.9	7	61.5	43.4	0.56	1.6	3.0	4100	0.0032	19
0.55	M3ARF 90 L	3GAR 094 402-••E	690	7.5	35	1.7	4.66	62.9	56.4	0.57	2.35	3.0	4100	0.0045	22
0.75	M3ARF 100 LA	3GAR 104 401-••E	700	10	44	2.1	4.4	72.0	63.6	0.59	2.55	3.5	3600	0.0073	31
1.1	M3ARF 100 LB	3GAR 104 402-••E	700	15	44	2.1	2.93	73.0	68.8	0.64	3.35	3.5	3700	0.0086	34
1.5	M3ARF 112 M	3GAR 114 401-••E	695	20.6	86	1.9	4.17	74.5	75.9	0.65	4.5	4.1	3600	0.016	41
2.2	M3ARF 132 S	3GAR 134 401-••E	720	29.2	130	1.6	4.45	80.5	77.8	0.67	5.9	5.3	3000	0.04	66
3	M3ARF 132 M	3GAR 134 402-••E	720	39.8	130	1.8	3.26	82.0	79.2	0.68	7.8	5.5	2600	0.047	73
4	M3ARF 160 MA	3GAR 164 401-••E	715	54	230	2.1	4.39	84.1	81.1	0.69	10	5.2	600	0.11	139
5.5	M3ARF 160 M	3GAR 164 402-••E	710	74	230	2.4	3.17	84.7	75.0	0.70	13.4	5.4	600	0.11	139
7.5	M3ARF 160 L	3GAR 164 403-••E	715	100	230	2.4	2.31	86.3	82.4	0.70	18.1	5.4	600	0.127	154

<sup>1)</sup> Braking-torque ratio

<sup>2)</sup> No-load (shaft-free) operations/hour

<sup>3)</sup> Temperature rise class F.

The bullets in the product code indicate choice of mounting arrangement and voltage and frequency code, see below and ordering information page.

### Code letters for supplementing product code for mounting arrangement:

Foot-mounted	<b>A</b>
Flange-mounted, 1 flange	<b>B</b> for frame sizes 63-100, 180; <b>E</b> for frame sizes 112-160.
Flange-mounted, 2 flanges	<b>N</b> for frame sizes 90-132
Flange-mounted, small flange	<b>C</b> for frame sizes 63-100

### Code letters for supplementing product code for voltage and frequency (pos 13):

Motor size	<b>S</b>			<b>D</b>			<b>X</b>
	Motor	Brake (input rectifier voltage/brake voltage)	Brake (input rectifier voltage/brake voltage)	Motor	Brake (input rectifier voltage/brake voltage)	Brake (input rectifier voltage/brake voltage)	
	50 Hz	60 Hz		50 Hz	60 Hz		
<b>63-132</b>	220-240 VΔ 380-420 VY	250-280 VΔ	220-240 V/205 V d.c.	380-420 VΔ 660-690 VY	440-480 VΔ	380-420 V/178 V d.c.	Any other rated voltage or frequency, 690 V maximum connection for motor and 500 V for brake (input rectifier)
<b>160-180</b>	230 VΔ 400 VY	265 VΔ	230 V/205 V d.c.	400 VΔ 690 VY	460 VΔ	400 V/178 V d.c.	
Motor size	<b>E</b>			<b>F</b>			
	Motor	Brake (input rectifier voltage/brake voltage)	Brake (input rectifier voltage/brake voltage)	Motor	Brake (input rectifier voltage/brake voltage)	Brake (input rectifier voltage/brake voltage)	
	50 Hz			50 Hz			
<b>63-80</b>	–	–	–	500 VY	–	500 V/223 V d.c.	
<b>90-180</b>	500 VΔ	–	500 V/223 V d.c.	500 VY	–	500 V/223 V d.c.	

# General purpose brake motors

## Technical data for two-speed DC brake motors

IP 55 – IC 411 – Insulation class F, temperature rise class F – Brake IP 23 S

Output kW	Motor type	Product code	Speed r/min	Torque				Efficiency %	Power factor cos φ	Current		Moment of inertia J=1/4GD <sup>2</sup> kgm <sup>2</sup>	Weight IM 1001 kg
				rated TN Nm	braking TB Nm	TS/TN	K <sup>1)</sup>			IN	IS/IN A		
<b>3000/1500 r/min = 2/4 poles</b>			<b>400 V 50 Hz</b>				<b>Constant torque, two separate windings</b>						
1.1/0.55	M3ARF 90 S	3GAR 098 401-••E	2900/1450	3.6/3.6	35	1.4/1.5	9.7/9.7	74/62	0.85/0.64	2.5/2	5.1/3.6	0.0019	20
1.5/0.75	M3ARF 90 L	3GAR 098 402-••E	2900/1450	4.9/4.9	35	1.5/1.5	7.1/7.1	77/70	0.87/0.67	3.3/2.4	5.7/4.1	0.0024	23
2.0/1.0	M3ARF 100 L	3GAR 108 401-••E	2900/1460	6.5/6.5	44	1.9/1.4	7.7/7.7	76/67	0.89/0.66	4.3/3.3	6.2/4	0.0041	32
2.6/1.3	M3ARF 112 M	3GAR 118 401-••E	2900/1460	8.6/8.5	86	1.6/1.6	10/9.9	80/75	0.92/0.72	5.1/3.5	6.4/5	0.012	45
4.4/2.2	M3ARF 132 SB	3GAR 138 401-••E	2925/1450	14.4/14.5	130	2/1.3	10.4/10	81/74	0.86/0.73	9.1/5.9	7.3/4.5	0.016	55
5.6/2.8	M3ARF 132 M	3GAR 138 402-••E	2885/1440	18.5/18.6	130	1.8/1.4	8.1/8.1	82/77	0.93/0.75	10.6/7	6.7/5	0.022	76
<b>3000/1500 r/min = 2-4 poles</b>			<b>400 V 50 Hz</b>				<b>Constant torque, Dahlander connection</b>						
0.2/0.15	M3VRF 63 A	3GVR 068 401-••C	2800/1400	0.68/1.02	7.5	2.1/2	11/7.4	63/54	0.7/0.63	0.65/0.65	3.6/2.8	0.00019	5
0.3/0.2	M3VRF 63 B	3GVR 068 402-••C	2740/1370	1.05/1.4	7.5	1.7/2.1	7.1/5.4	59/55	0.78/0.63	0.95/0.85	2.8/2.8	0.00026	5.5
0.37/0.25	M3VRF 71 A	3GVR 078 401-••E	2700/1390	1.3/1.72	10	1.9/1.5	9.2/7	64/60	0.89/0.79	0.95/0.7	3.3/3.1	0.00066	7
0.48/0.31	M3VRF 71 B	3GVR 078 402-••E	2780/1400	1.66/2.15	10	1.4/2	7.1/5.6	68/68	0.91/0.76	1.2/0.9	3.6/4	0.00089	8
0.55/0.37	M3VRF 71 C	3GVR 078 403-••E	2800/1400	1.87/2.52	10	1.8/1.9	6.4/4.8	66/64	0.8/0.65	1.5/1.2	4.7/4.3	0.0011	8.5
0.63/0.5	M3VRF 80 A	3GVR 088 401-••E	2690/1400	2.25/3.42	24	1.8/1.9	7.6/5.5	66/67	0.87/0.79	1.6/1.35	3.6/4.2	0.0013	11
0.85/0.65	M3VRF 80 B	3GVR 088 402-••E	2725/1405	2.99/4.43	24	1.9/2	5.4/3.6	70/70	0.88/0.8	2/1.7	4/4.4	0.0016	12.5
1.1/0.8	M3VRF 80 C	3GVR 088 403-••E	2730/1410	3.8/5.38	24	2/2	4.7/3.3	72/71	0.88/0.79	2.55/2.05	4.2/4.7	0.002	13
1.3/1	M3ARF 90 S	3GAR 098 403-••E	2730/1400	4.5/6.8	35	2/1.5	7.8/5.1	71/71	0.88/0.8	3.1/2.6	3.9/3.8	0.0032	20
1.9/1.5	M3ARF 90 L	3GAR 098 404-••E	2820/1420	6.4/10	35	2.8/2	5.5/3.5	74/75	0.82/0.76	4.4/3.9	5.1/4.4	0.0043	23
2.5/2.1	M3ARF 100 LA	3GAR 108 402-••E	2800/1430	8.5/14	44	2.2/1.6	5.9/3.6	68/76	0.88/0.81	6/5	4.8/4.4	0.0069	32
3.4/2.5	M3ARF 100 LB	3GAR 108 403-••E	2810/1430	11.5/18	44	2.2/1.9	4.3/2.7	78/80	0.88/0.85	7.2/5.9	5.3/5.4	0.0082	35
4/2.6	M3ARF 112 M	3GAR 118 402-••E	2865/1430	13.3/17.4	86	1.8/2.3	10/9.9	82/77	0.93/0.76	7.6/6.5	6.3/6.2	0.012	45
4.7/3.1	M3ARF 132 SB	3GAR 138 403-••E	2820/1420	15.9/20.8	130	1.8/2.2	10.4/10	79/77	0.92/0.76	9.2/7.7	5.5/5.7	0.016	55
6.3/4.4	M3ARF 132 SA	3GAR 138 411-••E	2895/1445	20.8/29	130	1.7/1.6	7.2/5.2	85/84	0.94/0.8	11.4/9.5	6.5/5.7	0.0155	58
7.2/4.8	M3ARF 132 M	3GAR 138 404-••E	2870/1435	24/31.9	130	2.4/2.5	6.3/4.7	84/81	0.92/0.76	13.3/11.5	7.1/6.2	0.022	76
8/6.2	M3ARF 132 SC	3GAR 138 412-••E	2910/1440	26.2/41.1	130	1.9/1.6	6.9/3.6	87/85	0.95/0.83	14/12.7	7.8/5.6	0.0215	78
9.6/7	M3ARF 132 MD	3GAR 138 413-••E	2900/1440	31.6/46.4	130	1.8/1.7	4.7/3.2	87/85	0.95/0.85	16.8/14.1	7.6/5.9	0.026	85
12.5/9	M3ARF 160 M	3GAR 168 404-••E	2890/1440	41/60	230	1.4/1.8	5.6/3.8	85.5/85.5	0.93/0.8	22.5/19	5.2/4.6	0.054	129
15/10.5	M3ARF 160 L	3GAR 168 405-••E	2900/1445	49/69	230	1.6/2.1	4.7/3.3	87/86	0.93/0.77	27/23	5.8/4.9	0.057	139
<b>1500/1000 r/min = 4/6 poles</b>			<b>400 V 50 Hz</b>				<b>Constant torque, two separate windings</b>						
0.11/0.08	M3VRF 63 B	3GVR 068 403-••C	1390/860	0.75/0.88	7.5	1.4/1.8	10/8.5	40/25	0.7/0.72	0.55/0.62	2.5/1.8	0.00026	5.5
0.3/0.2	M3VRF 71 A	3GVR 078 404-••E	1390/900	1.37/0.79	10	1.1/1.05	15.2/8.8	51/40	0.82/0.72	0.7/0.5	2.8/2	0.00066	7
0.37/0.22	M3VRF 71 B	3GVR 078 405-••E	1380/900	2.07/1.91	10	1/1.1	6.3/5.8	58/40	0.83/0.8	0.9/0.8	2.7/1.9	0.00089	8
0.43/0.28	M3VRF 80 A	3GVR 088 404-••E	1380/910	2.54/3.02	24	1.5/1.4	7.1/6	60/54	0.85/0.81	1.4/1.2	3.1/2.9	0.0019	12
0.58/0.37	M3VRF 80 B	3GVR 088 405-••E	1390/920	4/3.85	24	1.5/1.5	4/3.5	63/58	0.85/0.8	1.6/1.15	3.3/3.2	0.0022	12.5
0.8/0.5	M3ARF 90 S	3GAR 098 405-••E	1430/940	5.3/5	35	1.5/1.4	7/6.6	68/57	0.8/0.66	2.2/2	3.9/2.8	0.0032	20
1.2/0.75	M3ARF 90 L	3GAR 098 406-••E	1430/940	8/7.6	35	1.7/1.5	4.6/4.4	73/63	0.81/0.67	3/2.6	4.4/3.1	0.0043	23
1.5/0.9	M3ARF 100 LA	3GAR 108 404-••E	1440/960	9.9/8.9	44	1.5/1.5	5.6/5.1	75/69	0.84/0.65	3.5/3	4.7/3.8	0.0069	32
1.8/1.1	M3ARF 100 LB	3GAR 108 405-••E	1460/960	11/11	44	2.1/1.6	4.5/4.5	77/70	0.78/0.64	4.4/3.6	5.8/3.9	0.0082	35
2.6/1.7	M3ARF 112 M	3GAR 118 403-••E	1445/960	17.2/16.9	86	1.5/1.5	5/4.9	80/70	0.85/0.76	5.5/4.4	5.9/5.2	0.018	45
3.3/2.2	M3ARF 132 S	3GAR 138 405-••E	1470/980	21.4/21.4	130	1.4/1.2	7/7	82/76	0.8/0.65	7.1/6.4	6.8/4.6	0.038	61
4.5/3	M3ARF 132 M	3GAR 138 406-••E	1470/980	29.2/29.2	130	1.4/1.5	5.1/5.1	82/77	0.81/0.7	9.8/8	7.2/5.6	0.048	79
5.5/3.7	M3ARF 132 MD	3GAR 138 414-••E	1460/960	36/36.8	130	1.9/1.8	4.2/4.2	85/81	0.88/0.8	10.7/8.3	8/6.3	0.036	84
7.5/5.5	M3ARF 160 M	3GAR 168 406-••E	1465/965	49/54	230	2.1/1.8	3.1/2.7	85.5/80.5	0.83/0.77	15.5/13	7.1/4.7	0.089	129
11.5/8.5	M3ARF 160 L	3GAR 168 407-••E	1465/965	75/84	230	2.1/1.8	2.9/2.7	86.5/82.5	0.84/0.76	23/19.5	7/4.9	0.119	139

<sup>1)</sup> Braking-torque ratio

# General purpose brake motors

## Technical data for two-speed DC brake motors

IP 55 – IC 411 – Insulation class F, temperature rise class F – Brake IP 23 S

Output kW	Motor type	Product code	Speed r/min	Torque				Efficiency %	Power factor cos φ	Current		Moment of inertia J=1/4GD <sup>2</sup> kgm <sup>2</sup>	Weight IM 1001 kg
				rated TN Nm	braking TB Nm	TS/TN	K <sup>1)</sup>			IN	IS/IN A		
<b>3000/750 r/min = 2/8 poles</b>			<b>400 V 50 Hz</b>				<b>Constant torque, two separate windings</b>						
0.25/0.06	M3VRF 71 A	3GVR 078 408-••E	2760/660	0.86/0.86	10	1/1.3	14/14	52/36	0.94/0.7	0.75/0.35	2.9/1.9	0.00066	7
0.37/0.09	M3VRF 71 B	3GVR 078 409-••E	2800/660	1.26/1.3	10	1/1.6	9.5/9.2	68/41	0.87/0.65	0.9/0.5	2.8/2	0.00089	8
0.5/0.12	M3VRF 80 A	3GVR 088 409-••E	2730/700	1.78/1.64	24	1.3/2	10.9/9.6	60/38	0.87/0.58	1.4/0.8	3.2/2.3	0.0013	12.5
0.66/0.15	M3VRF 80 B	3GVR 088 410-••E	2780/700	2.55/2.45	24	1.4/2.2	7.3/7.1	65/40	0.87/0.58	1.65/0.95	3.8/2.5	0.0016	13
0.75/0.18	M3ARF 90 LA	3GAR 098 411-••E	2875/720	2.5/2.4	35	2.3/1.3	14/14	71.2/46.3	0.8/0.51	1.9/1.1	5.7/2.4	0.0043	23
1.3/0.33	M3ARF 90 LB	3GAR 098 412-••E	2780/690	4.4/4.5	35	1.8/1.2	8/8	71/52	0.92/0.62	2.9/1.5	4.5/2.3	0.0043	23
1.8/0.5	M3ARF 100 LB	3GAR 108 410-••E	2860/705	6.6/6.7	44	1.7/1.3	8.3/7.4	80/54	0.93/0.64	3.5/2.1	5.3/2.6	0.0082	35
2.2/0.59	M3ARF 112 MC	3GAR 118 406-••E	2900/720	7.2/7.8	86	2.4/1.6	11.8/11	78/62	0.87/0.55	4.9/2.5	7/3.5	0.015	42
3.3/0.95	M3ARF 132 SA	3GAR 138 415-••E	2940/730	10.7/12.4	130	2.6/1.2	14/12	81/72	0.95/0.52	6.2/3.7	9.5/4.3	0.0215	65
4.4/1.3	M3ARF 132 MC	3GAR 138 416-••E	2920/725	14.4/17.1	130	2.2/1.3	10.7/8.8	82/74	0.94/0.62	8.3/4.1	8.6/4	0.03	77
<b>1500/750 r/min = 4/8 poles</b>			<b>400 V 50 Hz</b>				<b>Constant torque, two separate windings</b>						
0.55/0.25	M3ARF 90 S	3GAR 098 407-••E	1450/700	3.6/3.4	35	1.3/1.4	10.3/9.7	62/51	0.78/0.59	1.9/1.2	4.2/2.3	0.0032	20
0.75/0.37	M3ARF 90 L	3GAR 098 408-••E	1450/700	4.9/5	35	1.4/1.5	7.1/7	66/57	0.75/0.57	2.2/1.7	4.1/2.5	0.0043	23
1.1/0.55	M3ARF 100 LA	3GAR 108 406-••E	1460/710	7.2/7.4	44	1.2/1.2	6.9/6.8	68/62	0.77/0.61	3.1/2.2	4.2/2.6	0.0069	32
1.5/0.75	M3ARF 100 LB	3GAR 108 407-••E	1440/700	9.8/10	44	1.3/1.2	5.1/5	72/60	0.82/0.6	3.7/2.9	4.6/2.7	0.0082	35
1.8/0.9	M3ARF 112 M	3GAR 118 404-••E	1460/715	11.7/12	86	1.2/1.6	7.3/7.1	77/65	0.76/0.66	4.4/3	6.5/4	0.018	45
2.5/1.3	M3ARF 132 S	3GAR 138 407-••E	1480/735	16.2/17	130	1.6/1.4	9.3/8.8	80/67	0.79/0.56	5.8/6	6/3.7	0.038	61
3.3/1.7	M3ARF 132 M	3GAR 138 408-••E	1470/725	21.4/22.4	130	1.6/1.4	7/6.7	81/71	0.79/0.58	7.5/6	7/4.2	0.048	79
<b>1500/750 r/min = 4-8 poles</b>			<b>400 V 50 Hz</b>				<b>Constant torque, Dahlander connection</b>						
0.11/0.06	M3VRF 63 B	3GVR 068 404-••C	1390/660	0.75/0.87	7.5	1.6/2.5	10/8.6	54/33	0.6/0.49	0.5/0.55	3/1.7	0.0026	5.5
0.18/0.11	M3VRF 71 A	3GVR 078 406-••E	1380/680	1.24/1.54	10	1.9/2.2	9.7/7.8	54/37	0.7/0.53	0.7/0.8	3.2/2.5	0.0066	7
0.3/0.15	M3VRF 71 B	3GVR 078 407-••E	1400/700	2.05/2.05	10	2/2.5	5.9/5.9	60/47	0.74/0.51	0.9/0.9	3.2/2.6	0.00089	8
0.45/0.25	M3VRF 80 A	3GVR 088 406-••E	1380/700	3.12/3.42	24	1.7/2.1	6.5/6	65/48	0.87/0.58	1.15/1.3	3.5/2.7	0.0019	11
0.63/0.33	M3VRF 80 B	3GVR 088 407-••E	1380/705	4.37/4.48	24	1.7/2.2	4/3.9	67/50	0.88/0.56	1.55/1.7	3.5/2.8	0.0022	12
0.75/0.37	M3VRF 80 C	3GVR 088 408-••E	1390/710	5.16/4.98	24	1.9/2.5	3.6/3.5	70/52	0.86/0.51	1.8/2	3.9/2.9	0.0025	12.5
0.7/0.37	M3ARF 90 S	3GAR 098 409-••E	1420/700	4.7/5.1	35	1.6/1.6	7.4/6.9	72/50	0.8/0.57	1.8/1.9	4.4/2.3	0.0032	20
1.1/0.55	M3ARF 90 L	3GAR 098 410-••E	1390/685	7.4/7.5	35	1.4/1.5	4.7/4.7	70/55	0.84/0.58	2.6/2.6	4.1/2.3	0.0043	23
1.5/0.75	M3ARF 100 LA	3GAR 108 408-••E	1440/710	10/10	44	1.4/1.5	5/5	76/62	0.85/0.57	3.4/3.2	4.6/2.8	0.0069	32
2/0.95	M3ARF 100 LB	3GAR 108 409-••E	1440/710	13/12	44	1.4/1.6	4.2/3.8	78/64	0.86/0.55	4.4/4	4.8/2.9	0.0082	35
2.5/1.5	M3ARF 112 M	3GAR 118 405-••E	1410/705	16.9/20.3	86	1.4/1.5	5/4.2	78/67	0.9/0.66	5.1/4.9	5.5/4.1	0.018	45
3.8/1.9	M3ARF 132 S	3GAR 138 409-••E	1450/730	25/24.9	130	1.4/1.3	6/6	82/70	0.84/0.52	7.7/7.6	5.6/3.7	0.038	61
5/2.5	M3ARF 132 M	3GAR 138 410-••E	1455/730	32.8/32.7	130	1.7/2	4.6/4.6	85/73	0.88/0.52	9.6/9.6	6.9/4.8	0.048	79
8/4.5	M3ARF 160 M	3GAR 168 410-••E	1440/730	53/59	230	1.3/1.4	4.3/3.9	84.5/79.5	0.86/0.6	16/13.5	4.5/3.4	0.089	129
12/7	M3ARF 160 L	3GAR 168 411-••E	1445/730	79/92	230	1.5/1.4	2.9/2.5	86.5/81	0.87/0.59	23/21	5/3.5	0.119	139

<sup>1)</sup> Braking-torque ratio

The bullets in the product code indicate choice of mounting arrangement and voltage and frequency code, see below and ordering information page.

### Code letters for supplementing product code for mounting arrangement (pos 12):

Foot-mounted	<b>A</b>
Flange-mounted, 1 flange	<b>B</b> for frame sizes 63-100, 180; <b>E</b> for frame sizes 112-160.
Flange-mounted, 2 flanges	<b>N</b> for frame sizes 90-132
Flange-mounted, small flange	<b>C</b> for frame sizes 63-100

### Code letters for supplementing product code for voltage and frequency (pos 13):

Motor size	<b>A</b>		<b>B</b>		<b>S</b>	
	Motor	Brake (input rectifier voltage/brake voltage)	Motor	Brake (input rectifier voltage/brake voltage)	Motor	Brake (input rectifier voltage/brake voltage)
63-132	50 Hz	220 V/205 V d.c.	50 Hz	380 V/178 V d.c.	220-230 V	220-230 V/205 V d.c.
160	220 V	220 V/205 V d.c.	380 V	380 V/178 V d.c.	230 V	230 V/205 V d.c.
Motor size	<b>D</b>		<b>E</b>		<b>X</b>	
	Motor	Brake (input rectifier voltage/brake voltage)	Motor	Brake (input rectifier voltage/brake voltage)	Any other rated voltage or frequency, 690 V maximum connection for motor and 500 V for brake (input rectifier)	
63-132	380-400 V	380-400 V/178 V d.c.	500 V	500 V/223 V d.c.		
160	400 V	400 V/178 V d.c.	500 V	500 V/223 V d.c.–		

# General purpose brake motors

## Technical data for single-speed motors with three phase AC brake

IP 55 – IC 411 – Insulation class F, temperature rise class B – Brake IP 23 S

Output kW	Motor type	Product code	Speed r/min	Torque			Efficiency		Power factor cos φ	Current			Moment of inertia J=1/4GD <sup>2</sup> kgm <sup>2</sup>	Weight foot mounted kg	
				rated TN Nm	braking TB Nm	TS/ TN	K <sup>1)</sup>	100%		75%	IN A	IS/IN			c/h <sup>2)</sup>
<b>3000 r/min = 2 pole</b>			<b>400 V 50 Hz</b>						<b>Basic design</b>						
0.18	M3VRS 63 A	3GVR 061 451-••C	2820	0.62	7.5	3.5	12.5	73.7	70.6	0.64	0.56	4.2	3500	0.00023	4.9
0.25	M3VRS 63 B	3GVR 061 452-••C	2810	0.87	7.5	3.6	8.33	77.5	75.8	0.71	0.66	4.5	3500	0.00026	5.4
0.37	M3VRS 71 A	3GVR 071 451-••E	2840	1.25	10	3.8	7.69	77.1	76.5	0.72	1	5.5	2600	0.00051	7
0.55	M3VRS 71 B	3GVR 071 452-••E	2830	1.86	10	3.6	5.26	79.2	78.2	0.76	1.35	5.7	2600	0.0006	8
0.75	M3VRS 80 A	3GVR 081 451-••E	2870	2.49	24	2.9	9.6	81.2	79.3	0.75	1.8	6.2	2000	0.00074	11
1.1	M3VRS 80 B	3GVR 081 452-••E	2850	3.69	24	2.3	6.48	81.4	79.5	0.78	2.5	6.1	2000	0.00078	12
1.5	M3ARS 90 S	3GAR 091 451-••E	2870	5	35	2.4	7	80.1	76.2	0.82	3.35	5.5	1300	0.0021	19
2.2	M3ARS 90 L	3GAR 091 452-••E	2880	7.5	35	2.7	4.6	83.6	83.9	0.87	4.37	7.0	1200	0.0026	22
3	M3ARS 100 L	3GAR 101 451-••E	2900	10	44	2.7	4.4	86.0	84.1	0.88	5.95	7.5	1000	0.00453	32
4	M3ARS 112 M	3GAR 111 451-••E	2850	13.4	86	2.8	6.41	86.0	86.2	0.91	7.4	7.5	500	0.01078	38
5.5	M3ARS 132 SA	3GAR 131 451-••E	2855	18.4	130	3.2	7.06	86.0	86.6	0.88	10.5	7.8	600	0.01657	57
7.5	M3ARS 132 SB	3GAR 131 452-••E	2860	25.1	130	3.4	5.17	88.0	86.2	0.89	13.9	8.5	500	0.01857	62
11	M3ARS 160 MA	3GAR 161 461-••E	2915	36	200	2.1	5.55	88.4	88.0	0.88	20.5	6.1	200	0.05096	124
15	M3ARS 160 M	3GAR 161 462-••E	2900	49	200	2.3	4.1	89.4	89.7	0.90	27	6.0	200	0.05596	134
18.5	M3ARS 160 L	3GAR 161 463-••E	2915	60	200	2.5	3.3	90.4	90.7	0.91	32.5	6.7	200	0.06396	139
22	M3ARS 180 M	3GAR 181 461-••E	2925	72	200	3	2.8	91.5	91.7	0.89	39	8.0	120	0.06264	158
<b>3000 r/min = 2 pole</b>			<b>400 V 50 Hz</b>						<b>High-output design</b>						
0.37	M3VRS 63 BB	3GVR 061 453-••C	2800	1.29	7.5	2.3	5.76	73.6	73.1	0.81	0.9	3.5	3500	0.00027	5.9
0.68	M3VRS 71 BB	3GVR 071 453-••E	2800	2.33	10	3.2	4.34	78.9	77.4	0.82	1.59	5.2	2400	0.0006	8
0.75	M3VRS 71 BC	3GVR 071 454-••E	2800	2.57	10	3.1	3.84	78.5	77.9	0.85	1.7	5.1	2400	0.0006	8
1.5	M3VRS 80 C	3GVR 081 453-••E	2840	5.13	24	2.8	4.7	82.4	82.2	0.83	3.16	5.5	1800	0.00111	13
2.7	<sup>3)</sup> M3ARS 90 LB	3GAR 091 453-••E	2860	9	35	2.6	3.9	80.7	83.5	0.86	5.7	7.0	1200	0.0029	24
4	<sup>3)</sup> M3ARS 100 LB	3GAR 101 452-••E	2900	13	44	2.7	3.38	85.0	84.3	0.86	8.1	7.5	1000	0.00543	36
5.5	<sup>3)</sup> M3ARS 112 MB	3GAR 111 452-••E	2855	18.4	86	2.7	4.67	86.5	87.1	0.93	9.9	7.3	500	0.01273	66
9.2	<sup>3)</sup> M3ARS 132 SBB	3GAR 131 454-••E	2825	31.1	130	3.2	4.18	86.0	88.2	0.93	16.6	7.3	500	0.02457	77
11	<sup>3)</sup> M3ARS 132 SC	3GAR 131 453-••E	2835	37	130	3.2	3.51	87.0	87.4	0.93	19.6	8.0	500	0.02383	77
22	<sup>3)</sup> M3ARS 160 LB	3GAR 161 454-••E	2920	72	200	2.6	2.77	92.1	93.0	0.91	38	7.1	200	0.06896	145

<sup>1)</sup> Braking-torque ratio    <sup>2)</sup> No-load (shaft-free) operations/hour    <sup>3)</sup> Temperature rise class F.

The bullets in the product code indicate choice of mounting arrangement and voltage and frequency code, see below and ordering information page.

### Code letters for supplementing product code for mounting arrangement:

Foot-mounted	<b>A</b>
Flange-mounted, 1 flange	<b>B</b> for frame sizes 63-100, 180; <b>E</b> for frame sizes 112-160.
Flange-mounted, 2 flanges	<b>N</b> for frame sizes 90-132
Flange-mounted, small flange	<b>C</b> for frame sizes 63-100

### Code letters for supplementing product code for voltage and frequency (pos 13):

Motor size	<b>S</b>				<b>D</b>				<b>G</b>		<b>H</b>		<b>X</b>
	Motor 50 Hz	Motor 60 Hz	Brake 50 Hz	Brake 60 Hz	Motor 50 Hz	Motor 60 Hz	Brake 50 Hz	Brake 60 Hz	Motor 50 Hz	Motor 50 Hz	Motor 50 Hz	Motor 50 Hz	
<b>63-132</b>	220-240 VΔ 380-420 VY	250-280 VΔ 440-480 VY	230 VΔ 400 VY	265 VΔ 460 VY	380-420 VΔ 660-690 VY	440-480 VΔ -	400 VΔ 690 VY	460 VΔ -	-	-	-	-	Any other rated voltage or frequency, 690V maximum
<b>160-180</b>	230 VΔ 400 VY	265 VΔ 460 VY	230 VΔ 400 VY	265 VΔ 460 VY	400 VΔ 690 VY	460 VΔ -	400 VΔ 690 VY	460 VΔ -	415 VY	415 VY	415 VΔ	415 VΔ	

# General purpose brake motors

## Technical data for single-speed motors with three phase AC brake

IP 55 – IC 411 – Insulation class F, temperature rise class B – Brake IP 23 S

Output kW	Motor type	Product code	Speed r/min	Torque			K <sup>1)</sup>	Efficiency		Power factor cos φ	Current			Moment of inertia J=1/4GD <sup>2</sup> kgm <sup>2</sup>	Weight foot mounted kg
				rated TN Nm	braking TB Nm	TS/ TN		100%	75%		IN A	IS/IN	c/h <sup>2)</sup>		
<b>1500 r/min = 4 poles</b>															
<b>400 V 50 Hz</b>															
<b>Basic design</b>															
0.12	M3VRS 63 A	3GVR 062 451-••C	1400	0.82	7.5	2.6	9.37	63.7	58.4	0.59	0.46	3.1	7100	0.00029	5
0.18	M3VRS 63 B	3GVR 062 452-••C	1380	1.25	7.5	2.5	5.76	65.6	62.1	0.64	0.63	3.1	7100	0.00036	5.5
0.25	M3VRS 71 A	3GVR 072 451-••E	1410	1.71	10	2.7	5.88	70.4	69.1	0.71	0.74	4.3	6500	0.00081	7
0.37	M3VRS 71 B	3GVR 072 452-••E	1420	2.51	10	2.6	4	74.6	72.1	0.69	1.05	4.4	6500	0.00104	8
0.55	M3VRS 80 A	3GVR 082 451-••E	1390	3.75	24	2.6	6.31	75.3	73.1	0.76	1.4	4.6	5000	0.00128	11
0.75	M3VRS 80 B	3GVR 082 452-••E	1410	5.08	24	3.5	4.7	78.2	75.6	0.74	1.9	4.7	5000	0.00159	12
1.1	M3ARS 90 S	3GAR 092 451-••E	1410	7.5	35	2.2	4.66	77.5	76.4	0.81	2.59	5.0	3200	0.0034	19
1.5	M3ARS 90 L	3GAR 092 452-••E	1420	10	35	2.4	3.5	80.3	78.1	0.79	3.45	5.0	3200	0.0045	22
2.2	M3ARS 100 LA	3GAR 102 451-••E	1430	15	44	2.4	2.93	83.0	82.7	0.81	4.8	5.5	2700	0.00733	32
3	M3ARS 100 LB	3GAR 102 452-••E	1430	20	44	2.5	2.2	85.0	83.9	0.81	6.48	5.5	2700	0.00863	35
4	M3ARS 112 M	3GAR 112 451-••E	1435	26.6	86	2.9	3.23	84.5	83.9	0.80	8.6	7.0	2500	0.01578	40
5.5	M3ARS 112 S	3GAR 132 451-••E	1450	36.2	130	2.2	3.59	87.0	87.7	0.83	11.1	7.3	1800	0.03357	60
7.5	M3ARS 132 M	3GAR 132 452-••E	1450	49.4	130	2.5	2.63	88.0	88.6	0.83	14.8	7.9	1400	0.04057	68
11	M3ARS 160 M	3GAR 162 461-••E	1465	72	230	2.4	3.2	88.4	88.8	0.78	22.5	6.9	500	0.07696	117
15	M3ARS 160 L	3GAR 162 462-••E	1460	98	230	2.8	2.3	90.0	90.5	0.82	29	7.2	500	0.08796	129
18.5	M3ARS 180 M	3GAR 182 461-••E	1455	121	230	2.6	1.9	90.4	90.4	0.84	35	7.0	360	0.10464	161
22	M3ARS 180 L	3GAR 182 462-••E	1460	144	230	3.0	1.6	91.1	91.5	0.82	42	8.0	360	0.12964	175

<b>1500 r/min = 4 poles</b>															
<b>400 V 50 Hz</b>															
<b>High-output design</b>															
0.25	M3VRS 63 BB	3GVR 062 453-••C	1370	1.75	7.5	2.5	4.28	70.3	67.4	0.67	0.78	3.2	7100	0.0004	6
0.45	M3VRS 71 BB	3GVR 072 453-••E	1390	3.11	10	2.1	3.22	75.5	75.3	0.76	1.15	4.1	6500	0.00104	8
0.55	M3VRS 71 C	3GVR 072 454-••E	1410	3.74	10	2.7	2.7	77.3	76.9	0.73	1.45	4.8	6500	0.00125	9
0.95	M3VRS 80 C	3GVR 082 453-••E	1410	6.44	24	2.9	3.75	78.9	77.9	0.75	2.35	4.3	500	0.00197	13
1.85 <sup>3)</sup>	M3ARS 90 L	3GAR 092 453-••E	1390	13	35	2.2	2.69	79.5	78.1	0.80	4.4	4.5	3200	0.0045	22
2.2 <sup>3)</sup>	M3ARS 90 LB	3GAR 092 454-••E	1390	15	35	2.2	2.33	80.3	81.0	0.83	4.85	4.5	3200	0.0048	23
4 <sup>3)</sup>	M3ARS 100 LC	3GAR 102 453-••E	1420	27	44	2.5	1.62	81.0	81.7	0.82	8.65	5.5	2700	0.009	36
5.5 <sup>3)</sup>	M3ARS 112 MB	3GAR 112 452-••E	1425	36.9	86	2.8	2.14	84.5	83.5	0.83	11.4	7.1	2500	0.018	47
9.2 <sup>3)</sup>	M3ARS 132 MBA	3GAR 132 454-••E	1450	60	130	2.0	2.14	88.0	88.6	0.85	17.8	7.3	1400	0.05	83
11 <sup>3)</sup>	M3ARS 132 MB	3GAR 132 453-••E	1450	72	130	2.5	1.79	88.0	89.4	0.86	21	8.3	500	0.05	83
18.5 <sup>3)</sup>	M3ARS 160 LB	3GAR 162 453-••E	1450	122	230	2.9	1.88	90.5	88.9	0.84	36	6.9	500	0.107	143

<sup>1)</sup> Braking-torque ratio    <sup>2)</sup> No-load (shaft-free) operations/hour    <sup>3)</sup> Temperature rise class F.

The bullets in the product code indicate choice of mounting arrangement and voltage and frequency code, see below and ordering information page.

### Code letters for supplementing product code for mounting arrangement:

Foot-mounted	<b>A</b>
Flange-mounted, 1 flange	<b>B</b> for frame sizes 63-100, 180; <b>E</b> for frame sizes 112-160.
Flange-mounted, 2 flanges	<b>N</b> for frame sizes 90-132
Flange-mounted, small flange	<b>C</b> for frame sizes 63-100

### Code letters for supplementing product code for voltage and frequency (pos 13):

Motor size	<b>S</b>				<b>D</b>				<b>G</b>		<b>H</b>		<b>X</b>
	Motor 50 Hz	Motor 60 Hz	Brake 50 Hz	Brake 60 Hz	Motor 50 Hz	Motor 60 Hz	Brake 50 Hz	Brake 60 Hz	Motor 50 Hz	Motor 50 Hz	Motor 50 Hz	Motor 50 Hz	
<b>63-132</b>	220-240 VΔ	250-280 VΔ	230 VΔ	265 VΔ	380-420 VΔ	440-480 VΔ	400 VΔ	460 VΔ	-	-	-	-	Any other rated voltage or frequency, 690V maximum
	380-420 VY	440-480 VY	400 VY	460 VY	660-690 VY	-	690 VY	-					
<b>160-180</b>	230 VΔ	265 VΔ	230 VΔ	265 VΔ	400 VΔ	460 VΔ	400 VΔ	460 VΔ	415 VY	415 VY	415 VΔ	415 VΔ	
	400 VY	460 VY	400 VY	460 VY	690 VY	-	690 VY	-					

# General purpose brake motors

## Technical data for single-speed motors with three phase AC brake

IP 55 – IC 411 – Insulation class F, temperature rise class B – Brake IP 23 S

Output kW	Motor type	Product code	Speed r/min	Torque			K <sup>1)</sup>	Efficiency		Power factor cos φ	Current			Moment of inertia J=1/4GD <sup>2</sup> kgm <sup>2</sup>	Weight foot mounted kg
				rated TN Nm	braking TB Nm	TS/TN		100%	75%		IN A	IS/IN	c/h <sup>2)</sup>		
<b>1000 r/min = 6 poles</b>			<b>400 V 50 Hz</b>					<b>Basic design</b>							
0.09	M3VRS 63 A	3GVR 063 451-••C	910	0.95	7.5	2.1	7.5	47.1	42.5	0.56	0.51	2.1	7700	0.0003	5
0.12	M3VRS 63 B	3GVR 063 452-••C	860	1.27	7.5	1.8	5.76	56.0	53.5	0.55	0.56	2.4	7700	0.00037	5.5
0.18	M3VRS 71 A	3GVR 073 451-••E	920	1.88	10	2.1	5.26	61.1	57.7	0.69	0.64	2.9	7500	0.00078	7
0.25	M3VRS 71 B	3GVR 073 452-••E	920	2.61	10	2.5	3.84	64.9	62.3	0.65	0.86	3.2	7500	0.00096	8
0.37	M3VRS 80 A	3GVR 083 451-••E	925	3.82	24	3.1	6.15	72.9	70.8	0.72	1.04	3.8	7000	0.00186	11
0.55	M3VRS 80 B	3GVR 083 452-••E	925	5.68	24	2.9	4.06	73.3	71.9	0.71	1.55	3.4	7000	0.0022	12
0.75	M3ARS 90 S	3GAR 093 451-••E	930	7.5	35	1.9	4.66	71.5	70.7	0.67	2.36	4.0	3800	0.0034	19
1.1	M3ARS 90 L	3GAR 093 452-••E	930	11	35	2.1	3.18	74.4	72.5	0.69	3.25	4.0	3900	0.0045	22
1.5	M3ARS 100 L	3GAR 103 451-••E	950	15	44	1.9	2.93	80.0	77.0	0.71	3.92	4.5	3300	0.0086	34
2.2	M3ARS 112 M	3GAR 113 451-••E	940	22.3	86	2.1	3.85	80.5	79.3	0.74	5.4	5.6	3200	0.015	40
3	M3ARS 132 S	3GAR 133 451-••E	960	29.8	130	2.0	4.36	84.5	82.7	0.75	6.9	6.1	2400	0.033	59
4	M3ARS 132 MA	3GAR 133 452-••E	960	39.7	130	2.0	3.27	85.5	83.1	0.78	8.7	7.1	1900	0.04	66
5.5	M3ARS 132 MB	3GAR 133 453-••E	955	55	130	2.2	2.36	86.0	85.0	0.78	11.9	6.9	1900	0.047	74
7.5	M3ARS 160 M	3GAR 163 451-••E	970	74	230	2.0	3.14	89.3	88.4	0.79	15.4	6.7	600	0.087	129
11	M3ARS 160 L	3GAR 163 452-••E	970	109	230	2.2	2.13	89.8	88.5	0.78	23	7.1	600	0.127	149
<b>1000 r/min = 6 poles</b>			<b>400 V 50 Hz</b>					<b>High-output design</b>							
0.15	M3VRS 63 BB	3GVR 063 453-••C	900	1.61	7.5	2.2	4.68	56.9	52.1	0.54	0.74	2.2	7700	0.00042	6
0.32	M3VRS 71 C	3GVR 073 453-••E	920	3.33	10	2.6	3.1	64.8	61.6	0.63	1.15	3.2	7500	0.00125	9
1.3	<sup>3)</sup> M3ARS 90 LB	3GAR 093 453-••E	910	13.5	35	1.9	2.59	69.0	69.0	0.71	3.85	4.0	3800	0.005	24
2.2	<sup>3)</sup> M3ARS 100 LC	3GAR 103 452-••E	940	22	44	1.9	2	77.0	72.8	0.71	5.9	4.5	3300	0.009	37
3	<sup>3)</sup> M3ARS 112 MB	3GAR 113 452-••E	935	30.6	86	2.0	2.81	80.0	79.9	0.76	7.2	5.5	3200	0.018	46
6.5	<sup>3)</sup> M3ARS 132 MC	3GAR 133 454-••E	960	64	130	2.0	2.01	85.0	84.5	0.75	14.8	6.6	2400	0.051	79
14	<sup>3)</sup> M3ARS 160 LB	3GAR 163 453-••E	960	139	230	2.7	1.65	89.1	84.5	0.77	29.5	7.6	1900	0.147	164

<sup>1)</sup> Braking-torque ratio

<sup>2)</sup> No-load (shaft-free) operations/hour

<sup>3)</sup> Temperature rise class F.

The bullets in the product code indicate choice of mounting arrangement and voltage and frequency code, see below and ordering information page.

### Code letters for supplementing product code for mounting arrangement:

Foot-mounted	<b>A</b>
Flange-mounted, 1 flange	<b>B</b> for frame sizes 63-100, 180; <b>E</b> for frame sizes 112-160.
Flange-mounted, 2 flanges	<b>N</b> for frame sizes 90-132
Flange-mounted, small flange	<b>C</b> for frame sizes 63-100

### Code letters for supplementing product code for voltage and frequency (pos 13):

Motor size	<b>S</b>				<b>D</b>				<b>G</b>		<b>H</b>		<b>X</b>
	Motor 50 Hz	Motor 60 Hz	Brake 50 Hz	Brake 60 Hz	Motor 50 Hz	Motor 60 Hz	Brake 50 Hz	Brake 60 Hz	Motor 50 Hz	Motor 50 Hz	Motor 50 Hz	Motor 50 Hz	
<b>63-132</b>	220-240 VΔ 380-420 VY	250-280 VΔ 440-480 VY	230 VΔ 400 VY	265 VΔ 460 VY	380-420 VΔ 660-690 VY	440-480 VΔ -	400 VΔ 690 VY	460 VΔ -	-	-	-	-	Any other rated voltage or frequency, 690V maximum
<b>160-180</b>	230 VΔ 400 VY	265 VΔ 460 VY	230 VΔ 400 VY	265 VΔ 460 VY	400 VΔ 690 VY	460 VΔ -	400 VΔ 690 VY	460 VΔ -	415 VY	415 VY	415 VΔ	415 VΔ	

# General purpose brake motors

## Technical data for single-speed motors with three phase AC brake

IP 55 – IC 411 – Insulation class F, temperature rise class B – Brake IP 23 S

Output kW	Motor type	Product code	Speed r/min	Torque			K <sup>1)</sup>	Efficiency		Power factor cos φ	Current			Moment of inertia J=1/4GD <sup>2</sup> kgm <sup>2</sup>	Weight foot mounted kg
				rated	braking	TS/TN		100%	75%		IN A	IS/IN	c/h <sup>2)</sup>		
<b>750 r/min = 8 poles</b>				<b>400 V 50 Hz</b>				<b>Basic design</b>							
0.055	M3VRS 63 B	3GVR 064 451-••E 680	680	7.5	0.78	2.1	9.4	38.3	31.8	0.48	0.45	1.8	7700	0.00037	5.5
0.09	M3VRS 71 A	3GVR 074 451-••E 690	690	10	1.25	2.3	7.69	45.8	37.5	0.57	0.52	2.2	7500	0.00078	7
0.12	M3VRS 71 B	3GVR 074 452-••E 690	690	10	1.67	2.5	5.88	46.4	38.1	0.55	0.69	2.2	7500	0.00096	8
0.18	M3VRS 80 A	3GVR 084 451-••E 700	700	24	2.46	3.2	9.6	59.9	54.5	0.60	0.75	3.1	7500	0.0022	11
0.25	M3VRS 80 B	3GVR 084 452-••E 700	700	24	3.52	2.9	6.85	70.7	67.4	0.62	0.85	3.1	7500	0.00245	12
0.37	M3ARS 90 S	3GAR 094 451-••E 700	700	35	5	1.9	7	61.5	43.4	0.56	1.6	3.0	4100	0.0034	19
0.55	M3ARS 90 L	3GAR 094 452-••E 690	690	35	7.5	1.7	4.66	62.9	56.4	0.57	2.35	3.0	4100	0.0045	22
0.75	M3ARS 100 LA	3GAR 104 451-••E 700	700	44	10	2.1	4.4	72.0	63.6	0.59	2.55	3.5	3600	0.0073	31
1.1	M3ARS 100 LB	3GAR 104 452-••E 700	700	44	15	2.1	2.93	73.0	68.8	0.64	3.35	3.5	3700	0.0086	34
1.5	M3ARS 112 M	3GAR 114 451-••E 695	695	86	20.6	1.9	4.17	74.5	75.9	0.65	4.5	4.1	3600	0.016	41
2.2	M3ARS 132 S	3GAR 134 451-••E 720	720	130	29.2	1.6	4.45	80.5	77.8	0.67	5.9	5.3	3000	0.04	66
3	M3ARS 132 M	3GAR 134 452-••E 720	720	130	39.8	1.8	3.26	82.0	79.2	0.68	7.8	5.5	2600	0.047	73
4	M3ARS 160 MA	3GAR 164 451-••E 715	715	230	54	2.1	4.39	84.1	81.1	0.69	10	5.2	600	0.11	139
5.5	M3ARS 160 M	3GAR 164 452-••E 710	710	230	74	2.4	3.17	84.7	75.0	0.70	13.4	5.4	600	0.11	139
7.5	M3ARS 160 L	3GAR 164 453-••E 715	715	230	100	2.4	2.31	86.3	82.4	0.70	18.1	5.4	600	0.127	154

<sup>1)</sup> Braking-torque ratio

<sup>2)</sup> No-load (shaft-free) operations/hour

The bullets in the product code indicate choice of mounting arrangement and voltage and frequency code, see below and ordering information page.

### Code letters for supplementing product code for mounting arrangement:

Foot-mounted	<b>A</b>
Flange-mounted, 1 flange	<b>B</b> for frame sizes 63-100, 180; <b>E</b> for frame sizes 112-160.
Flange-mounted, 2 flanges	<b>N</b> for frame sizes 90-132
Flange-mounted, small flange	<b>C</b> for frame sizes 63-100

### Code letters for supplementing product code for voltage and frequency (pos 13):

Motor size	<b>S</b>				<b>D</b>				<b>G</b>		<b>H</b>		<b>X</b>
	Motor 50 Hz	Motor 60 Hz	Brake 50 Hz	Brake 60 Hz	Motor 50 Hz	Motor 60 Hz	Brake 50 Hz	Brake 60 Hz	Motor 50 Hz	Motor 50 Hz	Motor 50 Hz	Motor 50 Hz	
<b>63-132</b>	220-240 VΔ 380-420 VY	250-280 VΔ 440-480 VY	230 VΔ 400 VY	265 VΔ 460 VY	380-420 VΔ 660-690 VY	440-480 VΔ –	400 VΔ 690 VY	460 VΔ –	–	–	–	–	Any other rated voltage or frequency, 690V maximum
<b>160-180</b>	230 VΔ 400 VY	265 VΔ 460 VY	230 VΔ 400 VY	265 VΔ 460 VY	400 VΔ 690 VY	460 VΔ –	400 VΔ 690 VY	460 VΔ –	415 VY	415 VY	415 VΔ	415 VΔ	

# General purpose brake motors

## Technical data for two-speed motors with three phase AC brake

IP 55 – IC 411 – Insulation class F, temperature rise class F – Brake IP 23 S

Output kW	Motor type	Product code	Speed r/min	Torque				Efficiency %	Power factor cos φ	Current		Moment of inertia J=1/4GD <sup>2</sup> kgm <sup>2</sup>	Weight IM 1001 kg
				TN Nm	braking TB Nm	TS/TN	K <sup>1)</sup>			IN	IS/IN A		
<b>3000/1500 r/min = 2-4 poles</b>			<b>400 V 50 Hz</b>				<b>Constant torque, two separate windings</b>						
1.1/0.55	M3ARS90 S	3GAR 098 451-••E	2900/1450	3.6/3.6	35	1.4/1.5	9.7/9.7	74/62	0.85/0.64	2.5/2	5.1/3.6	0,0019	20
1.5/0.75	M3ARS90 L	3GAR 098 452-••E	2900/1450	4.9/4.9	35	1.5/1.5	7.1/7.1	77/70	0.87/0.67	3.3/2.4	5.7/4.1	0,0024	23
2/1	M3ARS100 L	3GAR 108 451-••E	2900/1460	6.5/6.5	44	1.9/1.4	7.7/7.7	76/67	0.89/0.66	4.3/3.3	6.2/4	0,0041	32
2.6/1.3	M3ARS112 M	3GAR 118 451-••E	2900/1460	8.6/8.5	86	1.6/1.6	10/9.9	80/75	0.92/0.72	5.1/3.5	6.4/5	0,012	45
4.4/2.2	M3ARS132 SB	3GAR 138 451-••E	2925/1450	14.4/14.5	130	2/1.3	8.1/8.1	81/74	0.86/0.73	9.1/5.9	7.3/4.5	0,016	55
5.6/2.8	M3ARS132 M	3GAR 138 452-••E	2885/1440	18.5/18.6	130	1.8/1.4	10.4/10	82/77	0.93/0.75	10.6/7	6.7/5	0,022	76
<b>3000/1500 r/min = 2-4 poles</b>			<b>400 V 50 Hz</b>				<b>Constant torque, Dahlander-connection</b>						
0.2/0.15	M3VRS 63 A	3GVR 068 451-••C	2800/1400	0.68/1.02	7.5	2.1/2	7.1/5.4	63/54	0.7/0.63	0.65/0.65	3.6/2.8	0.00019	5
0.3/0.2	M3VRS 63 B	3GVR 068 452-••C	2740/1370	1.05/1.4	7.5	1.7/2.1	11/7.4	59/55	0.78/0.63	0.95/0.85	2.8/2.8	0.00026	5.5
0.37/0.25	M3VRS 71 A	3GVR 078 451-••E	2700/1390	1.3/1.72	10	1.9/1.5	9.2/7	64/60	0.89/0.79	0.95/0.7	3.3/3.1	0.00066	7
0.48/0.31	M3VRS 71 B	3GVR 078 452-••E	2780/1400	1.66/2.15	10	1.4/2	7.1/5.6	68/68	0.91/0.76	1.2/0.9	3.6/4	0.00089	8
0.55/0.37	M3VRS 71 C	3GVR 078 453-••E	2800/1400	1.87/2.52	10	1.8/1.9	6.4/4.8	66/64	0.8/0.65	1.5/1.2	4.7/4.3	0.0011	8.5
0.63/0.5	M3VRS 80 A	3GVR 088 451-••E	2690/1400	2.25/3.42	24	1.8/1.9	7.6/5.5	66/67	0.87/0.79	1.6/1.35	3.6/4.2	0.0013	11
0.85/0.65	M3VRS 80 B	3GVR 088 452-••E	2725/1405	2.99/4.43	24	1.9/2	5.4/3.6	70/70	0.88/0.8	2/1.7	4/4.4	0.0016	12.5
1.1/0.8	M3VRS 80 C	3GVR 088 453-••E	2730/1410	3.8/5.38	24	2/2	4.7/3.3	72/71	0.88/0.79	2.55/2.05	4.2/4.7	0.002	13
1.3/1	M3ARS90 S	3GAR 098 453-••E	2730/1400	4.5/6.8	35	2/1.5	7.8/5.1	71/71	0.88/0.8	3.1/2.6	3.9/3.8	0.0032	20
1.9/1.5	M3ARS90 L	3GAR 098 454-••E	2820/1420	6.4/10	35	2.8/2	5.4/3.5	74/75	0.82/0.76	4.4/3.9	5.1/4.4	0.0043	23
2.5/2.1	M3ARS100 LA	3GAR 108 452-••E	2800/1430	8.5/14	44	2.2/1.6	5.9/3.6	68/76	0.88/0.81	6/5	4.8/4.4	0.0069	32
3.4/2.5	M3ARS100 LB	3GAR 108 453-••E	2810/1430	11.5/18	44	2.2/1.9	4.3/2.7	78/80	0.88/0.85	7.2/5.9	5.3/5.4	0.0082	35
4.26	M3ARS112 M	3GAR 118 452-••E	2865/1430	13.3/17.4	86	1.8/2.3	10/9.9	82/77	0.93/0.76	7.6/6.5	6.3/6.2	0.012	45
6.3/4.4	M3ARS132 SA	3GAR 138 461-••E	2895/1445	20.8/29	130	1.7/1.6	7.2/5.2	85/84	0.94/0.8	11.4/9.5	6.5/5.7	0.0155	58
4.7/3.1	M3ARS132 SB	3GAR 138 453-••E	2820/1420	15.9/20.8	130	1.8/2.2	10.4/10	79/77	0.92/0.76	9.2/7.7	5.5/5.7	0.016	55
8/6.2	M3ARS132 SC	3GAR 138 462-••E	2910/1440	26.2/41.1	130	1.9/1.6	6.9/3.6	87/85	0.95/0.83	14/12.7	7.8/5.6	0.0215	78
7.2/4.8	M3ARS132 M	3GAR 138 454-••E	2870/1435	24/31.9	130	2.4/2.5	6.3/4.7	84/81	0.92/0.76	13.3/11.5	7.1/6.2	0.022	76
9.6/7	M3ARS132 MD	3GAR 138 463-••E	2900/1440	31.6/46.4	130	1.8/1.7	4.7/3.2	87/85	0.95/0.85	16.8/14.1	7.6/5.9	0.026	85
12.5/9	M3ARS160 M	3GAR 168 454-••E	2890/1440	41/60	200	1.4/1.8	5.6/3.8	85.5/85.5	0.93/0.8	22.5/19	5.2/4.6	0.054	129
15/10.5	M3ARS160 L	3GAR 168 455-••E	2900/1445	49/69	200	1.6/2.1	4.7/3.3	87/86	0.93/0.77	27/23	5.8/4.9	0.057	139
<b>1500/1000 r/min = 4/6 poles</b>			<b>400 V 50 Hz</b>				<b>Constant torque, two separate windings</b>						
0.11/0.08	M3VRS 63 B	3GVR 068 453-••C	1390/860	0.75/0.88	7.5	1.4/1.8	10/8.5	40/25	0.7/0.72	0.55/0.62	2.5/1.8	0.00026	5.5
0.3/0.2	M3VRS 71 A	3GVR 078 454-••E	1390/900	1.37/0.79	10	1.1/1.05	15.2/8.8	51/40	0.82/0.72	0.7/0.5	2.8/2	0.00066	7
0.37/0.22	M3VRS 71 B	3GVR 078 455-••E	1380/900	2.07/1.91	10	1/1.1	6.3/5.8	58/40	0.83/0.8	0.9/0.8	2.7/1.9	0.00089	8
0.43/0.28	M3VRS 80 A	3GVR 088 454-••E	1380/910	2.54/3.02	24	1.5/1.4	7.1/6	60/54	0.85/0.81	1.4/1.2	3.1/2.9	0.0019	12
0.58/0.37	M3VRS 80 B	3GVR 088 455-••E	1390/920	4/3.85	24	1.5/1.5	4/3.5	63/58	0.85/0.8	1.6/1.15	3.3/3.2	0.0022	12.5
0.8/0.5	M3ARS90 S	3GAR 098 455-••E	1430/940	5.3/5	35	1.5/1.4	7/6.6	68/57	0.8/0.66	2.2/2	3.9/2.8	0.0032	20
1.2/0.75	M3ARS90 L	3GAR 098 456-••E	1430/940	8/7.6	35	1.7/1.5	4.6/4.4	73/63	0.81/0.67	3/2.6	4.4/3.1	0.0043	23
1.5/0.9	M3ARS100 LA	3GAR 108 454-••E	1440/960	9.9/8.9	44	1.5/1.5	5.6/5.1	75/69	0.84/0.65	3.5/3	4.7/3.8	0.0069	32
1.8/1.1	M3ARS100 LB	3GAR 108 455-••E	1460/960	11/11	44	2.1/1.6	4.5/4.5	77/70	0.78/0.64	4.4/3.6	5.8/3.9	0.0082	35
2.6/1.7	M3ARS112 M	3GAR 118 453-••E	1445/960	17.2/16.9	86	1.5/1.5	5/4.9	80/70	0.85/0.76	5.5/4.4	5.9/5.2	0.018	45
3.3/2.2	M3ARS132 S	3GAR 138 455-••E	1470/980	21.4/21.4	130	1.4/1.2	4.5/3.0	82/76	0.8/0.65	7.1/6.4	6.8/4.6	0.038	61
3.3/2.2	M3ARS132 M	3GAR 138 456-••E	1470/980	29.2/29.2	130	1.4/1.5	5.1/5.1	82/77	0.81/0.7	9.8/8	7.2/5.6	0.048	79
5.5/3.7	M3ARS132 MD	3GAR 138 464-••E	1460/960	36/36.8	130	1.9/1.8	4.2/4.2	85/81	0.88/0.8	10.7/8.3	8/6.3	0.036	84
7.5/5.5	M3ARS160 M	3GAR 168 456-••E	1465/965	49/54	230	2.1/1.8	3.1/2.7	85.5/80.5	0.83/0.77	15.5/13	7.1/4.7	0.089	129
11.5/8.5	M3ARS160 L	3GAR 168 457-••E	1465/965	75/84	230	2.1/1.8	2.9/2.7	86.5/82.5	0.84/0.76	23/19.5	7/4.9	0.119	139

<sup>1)</sup> Braking-torque ratio

# General purpose brake motors

## Technical data for two-speed motors with three phase AC brake

IP 55 – IC 411 – Insulation class F, temperature rise class F – Brake IP 23 S

Output kW	Motor type	Product code	Speed r/min	Torque				Efficiency %	Power factor cos φ	Current		Moment of inertia J=1/4GD <sup>2</sup> kgm <sup>2</sup>	Weight IM 1001 kg
				TN Nm	braking TB Nm	TS/TN	K <sup>1)</sup>			IN	IS/IN A		
<b>3000/750 r/min = 2/8 poles</b>			<b>400 V 50 Hz</b>				<b>Constant torque, two separate windings</b>						
0.25/0.06	M3VRS 71 A	3GVR 078 458-••E	2760/660	0.86/0.86	10	1/1.3	14/14	52/36	0.94/0.7	0.75/0.35	2.9/1.9	0,00066	7
0.37/0.09	M3VRS 71 B	3GVR 078 459-••E	2800/660	1.26/1.3	10	1/1.6	9.5/9.2	68/41	0.87/0.65	0.9/0.5	2.8/2	0,00089	8
0.5/0.12	M3VRS 80 A	3GVR 088 459-••E	2730/700	1.78/1.64	24	1.3/2	10.9/9.6	60/38	0.87/0.58	1.4/0.8	3.2/2.3	0,0013	12,5
0.66/0.15	M3VRS 80 B	3GVR 088 460-••E	2780/700	2.55/2.45	24	1.4/2.2	7.3/7.1	65/40	0.87/0.58	1.65/0.95	3.8/2.5	0,0016	13
0.75/0.18	M3ARS 90 LA	3GAR 098 461-••E	2875/720	2.5/2.4	35	2.3/1.3	14/14	71.2/46.3	0.8/0.51	1.9/1.1	5.7/2.4	0,0043	23
1.3/0.33	M3ARS 90 LB	3GAR 098 462-••E	2780/690	4.4/4.5	35	1.8/1.2	8/8	71/52	0.92/0.62	2.9/1.5	4.5/2.3	0,0043	23
1.8/0.5	M3ARS 100 LB	3GAR 108 460-••E	2860/705	6.0/6.7	44	1.7/1.3	8.3/7.4	80/54	0.93/0.64	3.5/2.1	5.3/2.6	0,0082	35
2.2/0.59	M3ARS 112 MC	3GAR 118 456-••E	2900/720	7.2/7.8	86	2.4/1.6	11.8/11	78/62	0.87/0.55	4.9/2.5	7/3.5	0,015	42
3.3/0.95	M3ARS 132 SA	3GAR 138 465-••E	2940/730	10.7/12.4	130	2.6/1.2	14/12	81/72	0.95/0.52	6.2/3.7	9.5/4.3	0,0215	65
4.4/1.3	M3ARS 132 MC	3GAR 138 466-••E	2920/725	14.4/17.1	130	2.2/1.3	10.7/8.8	82/74	0.94/0.62	8.3/4.1	8.6/4	0,03	77
<b>1500/750 r/min = 4/8 poles</b>			<b>400 V 50 Hz</b>				<b>Constant torque, two separate windings</b>						
0.55/0.25	M3ARS 90 S	3GAR 098 457-••E	1450/700	3.6/3.4	35	1.3/1.4	10.3/9.7	62/51	0.78/0.59	1.9/1.2	4.2/2.3	0.0032	20
0.75/0.37	M3ARS 90 L	3GAR 098 458-••E	1450/700	4.9/5	35	1.4/1.5	7.1/7	66/57	0.75/0.57	2.2/1.7	4.1/2.5	0.0043	23
1.1/0.55	M3ARS 100 LA	3GAR 108 456-••E	1460/710	7.2/7.4	44	1.2/1.2	6.9/6.8	68/62	0.77/0.61	3.1/2.2	4.2/2.6	0.0069	32
1.5/0.75	M3ARS 100 LB	3GAR 108 457-••E	1440/700	9.8/10	44	1.3/1.2	5.1/5	72/60	0.82/0.6	3.7/2.9	4.6/2.7	0.0082	35
1.8/0.9	M3ARS 112 M	3GAR 118 454-••E	1460/715	11.7/12	86	1.2/1.6	7.3/7.1	77/65	0.76/0.66	4.4/3	6.5/4	0.018	45
2.5/1.3	M3ARS 132 S	3GAR 138 457-••E	1480/735	16.2/17	130	1.6/1.4	9.3/8.8	80/67	0.79/0.56	5.8/6	6/3.7	0.038	61
3.3/1.7	M3ARS 132 M	3GAR 138 458-••E	1470/725	21.4/22.4	130	1.6/1.4	7/6.7	81/71	0.79/0.58	7.5/6	7/4.2	0.048	79
<b>1500/750 r/min = 4-8 poles</b>			<b>400 V 50 Hz</b>				<b>Constant torque, Dahlander-connection</b>						
0.11/0.06	M3VRS 63 B	3GVR 068 454-••C	1390/660	0.75/0.87	7.5	1.6/2.5	10/8.6	54/33	0.6/0.49	0.5/0.55	3/1.7	0.00026	5.5
0.18/0.11	M3VRS 71 A	3GVR 078 456-••E	1380/680	1.24/1.54	10	1.9/2.2	9.7/7.8	54/37	0.7/0.53	0.7/0.8	3.2/2.5	0.00066	7
0.3/0.15	M3VRS 71 B	3GVR 078 457-••E	1400/700	2.05/2.05	10	2/2.5	5.9/5.9	60/47	0.74/0.51	0.9/0.9	3.2/2.6	0.00089	8
0.45/0.25	M3VRS 80 A	3GVR 088 456-••E	1380/700	3.12/3.42	24	1.7/2.1	6.5/6	65/48	0.87/0.58	1.15/1.3	3.5/2.7	0.0019	11
0.63/0.33	M3VRS 80 B	3GVR 088 457-••E	1380/705	4.37/4.48	24	1.7/2.2	4/3.9	67/50	0.88/0.56	1.55/1.7	3.5/2.8	0.0022	12
0.75/0.37	M3VRS 80 C	3GVR 088 458-••E	1390/710	5.16/4.98	24	1.9/2.5	3.6/3.5	70/52	0.86/0.51	1.8/2	3.9/2.9	0.0025	12.5
0.7/0.37	M3ARS 90 S	3GAR 098 459-••E	1420/700	4.7/5.1	35	1.6/1.6	7.4/6.9	72/50	0.8/0.57	1.8/1.9	4.4/2.3	0.0032	20
1.1/0.55	M3ARS 90 L	3GAR 098 460-••E	1390/685	7.4/7.5	35	1.4/1.5	4.7/4.7	70/55	0.84/0.58	2.6/2.6	4.1/2.3	0.0043	23
1.5/0.75	M3ARS 100 LA	3GAR 108 458-••E	1440/710	10/10	44	1.4/1.5	5/5	76/62	0.85/0.57	3.4/3.2	4.6/2.8	0.0069	32
2/0.95	M3ARS 100 LB	3GAR 108 459-••E	1440/710	13/12	44	1.4/1.6	4.2/3.8	78/64	0.86/0.55	4.4/4	4.8/2.9	0.0082	35
2.5/1.5	M3ARS 112 M	3GAR 118 455-••E	1410/705	16.9/20.3	86	1.4/1.5	5/4.2	78/67	0.9/0.66	5.1/4.9	5.5/4.1	0.018	45
3.8/1.9	M3ARS 132 S	3GAR 138 459-••E	1450/730	25/24.9	130	1.4/1.3	6/6	82/70	0.84/0.52	7.7/7.6	5.6/3.7	0.038	61
5/2.5	M3ARS 132 M	3GAR 138 460-••E	1455/730	32.8/32.7	130	1.7/2	4.6/4.6	85/73	0.88/0.52	9.6/9.6	6.9/4.8	0.048	79
8/4.5	M3ARS 160 M	3GAR 168 460-••E	1440/730	53/59	230	1.3/1.4	4.3/3.9	84.5/79.5	0.86/0.6	16/13.5	4.5/3.4	0.089	129
12/7	M3ARS 160 L	3GAR 168 461-••E	1445/730	79/92	230	1.5/1.4	2.9/2.5	86.5/81	0.87/0.59	23/21	5/3.5	0.119	139

<sup>1)</sup> Braking-torque ratio

The bullets in the product code indicate choice of mounting arrangement and voltage and frequency code, see below and ordering information page.

### Code letters for supplementing product code for mounting arrangement (pos 12):

Foot-mounted	<b>A</b>
Flange-mounted, 1 flange	<b>B</b> for frame sizes 63-100, 180; <b>E</b> for frame sizes 112-160.
Flange-mounted, 2 flanges	<b>N</b> for frame sizes 90-132
Flange-mounted, small flange	<b>C</b> for frame sizes 63-100

### Code letters for supplementing product code for voltage and frequency (pos 13):

Motor size	<b>A</b>		<b>B</b>		<b>S</b>		<b>D</b>	
	Motor 50 Hz	Brake 50 Hz	Motor 50 Hz	Brake 50 Hz	Motor 50 Hz	Brake 50 Hz	Motor 50 Hz	Brake 50 Hz
63-132	-	-	-	-	220-230 V	230 VΔ	380-400 V	400 VΔ
160	220 V	220 VΔ	380 V	380 VΔ	230 V	230 VΔ	400 V	400 VΔ
Motor size	<b>E</b>		<b>H</b>		<b>X</b>			
	Motor 50 Hz	Brake 50 Hz	Motor 50 Hz	Brake 50 Hz	Any other rated voltage or frequency, 690 V maximum			
63-132	500 V	500 VΔ	415 V	415 VΔ	Any other rated voltage or frequency, 690 V maximum			
160	500 V	500 VΔ	415 V	415 VΔ	Any other rated voltage or frequency, 690 V maximum			

# General purpose brake motors - Variant codes

Code	Variant	M3VRF/S			M3ARF/S					
		63	71	80	90	100	112	132	160	180
<b>Brakes</b>										
086	Separate brake supply	M	M	M	M	M	M	M	M	M
087	Brake with reduced torque, torque range 60%-33% of nominal torque.	NA	P	P	P	P	P	P	P	p
088	Hand release	M	S	S	S	S	S	S	S	S
213	Brake with increased degree of protection. Rubber ring and V-ring for IP55 protection.	M	M	M	M	M	M	M	M	M
285	Reconnection of brake for separate dc supply at 24 V.	R	M	M	M	M	M	M	M	M
288	Brake motor with voltage code S for the motor and separate supply of the brake for voltage corresponding to code D.	R	M	M	M	M	M	M	M	M
289	Brake motor with voltage code D for the motor and separate supply of the brake for voltage corresponding to code S.	R	M	M	M	M	M	M	M	M
290	Brake motor with a.c. brake, change into d.c. brake keeping the voltage code.	R	M	M	M	M	M	M	M	M
291	Brake motor with d.c. brake, change into a.c. brake keeping the voltage code.	R	M	M	M	M	M	M	M	M
<b>Special voltage</b>										
209	Non-standard voltage or frequency (special winding) Different brake coil (e.g. 25 Vdc), max. 500 Vac.	R	R	R	P	P	P	P	P	P
<b>Protection</b>										
005	Protective roof, for vertical mounting with shaft end downwards.	M	M	M	M	M	M	M	M	M

For other variant codes please see section for standard aluminum motors or consult ABB.

- S** = Included as standard
- P** = New manufacture only.
- M** = On modification of a stocked motor or on new manufacture, the number per order may be limited.
- R** = On request.
- NA** = Not applicable.

## Brake rating plates

The brake rating plates have the following arrangement:

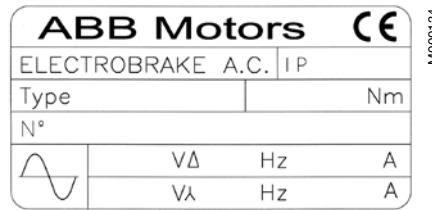
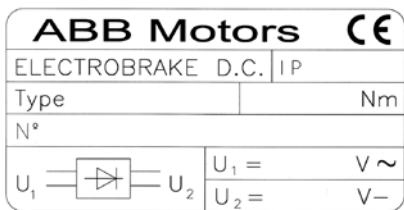

# General purpose brake motors

# Sizes 63-180

## Dimension drawings

IM B3 (IM 1001)

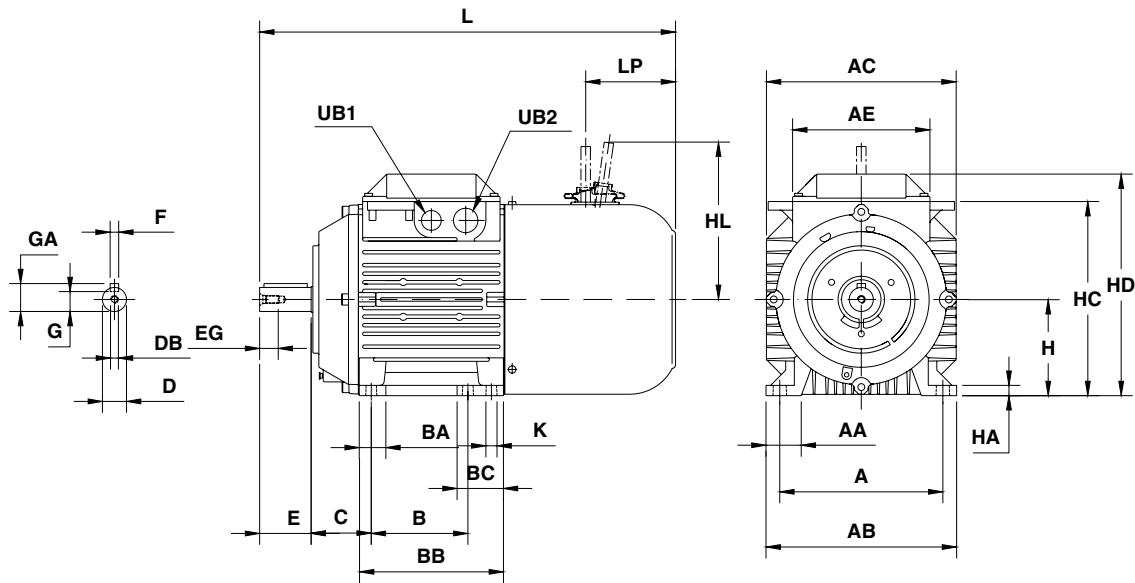

M000135

Motor size	A	AA	AB	AC	AE	B	BA	BB	BC	C	D	DB	E	EG
63 A/B	100	26	120	123	85	80	21	96	21	40	11	M4	23	10
71	112	24	136	139	85	90	31	110	31	45	14	M5	30	13
80	125	28	154	156	97	100	34	125	34	50	19	M6	40	16
90S	140	27	170	177	110	100	30	125	30	56	24	M8	50	19
90 L	140	27	170	177	110	125	30	150	30	56	24	M8	50	19
100 L	160	32	197	197	110	140	34	172	34	63	28	M10	60	22
112 M	190	41	222	221	160	140	31	168	31	70	28	M10	60	22
132 S	216	47	262	261	160	140	40	212	76	89	38	M12	80	28
132 M	216	47	262	261	160	178	40	212	76	89	38	M12	80	28
160 M	254	56	310	314	210	210	55	287.5	86	108	42	M16	110	36
160 L	254	56	310	314	210	254	55	287.5	86	108	42	M16	110	36
180	279	65.5	340	314	210	241	91	329	91	121	48	M16	110	36

Motor size	F	GA	H	HA	HC	HD	HL	K	L	LP	UB1	UB2
63 A/B	4	12.5	63	10	-	180	107	7	270	66	M16	Pg11
71	5	16	71	9	-	176	114	7	316	76	M20	Pg16
80	6	21.5	80	10	-	190	124	10	360	70	M20	Pg16
90S	8	27	90	10	177	217	161	10	370	70	M20	M25
90 L	8	27	90	10	177	217	161	10	395	70	M20	M25
100 L	8	31	100	12	197	237	173	12	453	105	M20	M25
112 M	8	31	112	12	226	258	184	12	487	105	M20	M25
132 S	10	41	132	14	264	296	225	12	606	119	M20	M25
132 M	10	41	132	14	264	296	225	12	606	119	M20	M25
160 M	12	45	160	20	325	369	253	15	782	139	M40	M40
160 L	12	45	160	20	325	369	253	15	782	139	M40	M40
180	14	51.5	180	20	345	389	253	15	782	139	M40	M40

Tolerances:

- D ISO j6 ( $\leq 28 \text{ } \varnothing$ )
- D ISO k6 (38-42  $\varnothing$ )
- F ISO h9
- H + 0, - 0.5

Above table gives the main dimensions in mm.  
For detailed drawings please see our web-pages  
'[www.abb.com/motors&generators](http://www.abb.com/motors&generators)' or contact us.

# General purpose brake motors

# Sizes 63-180

## Dimension drawings

IM B5 (IM 3001), IM V1 (IM 3011), IM B14 (IM 3601)

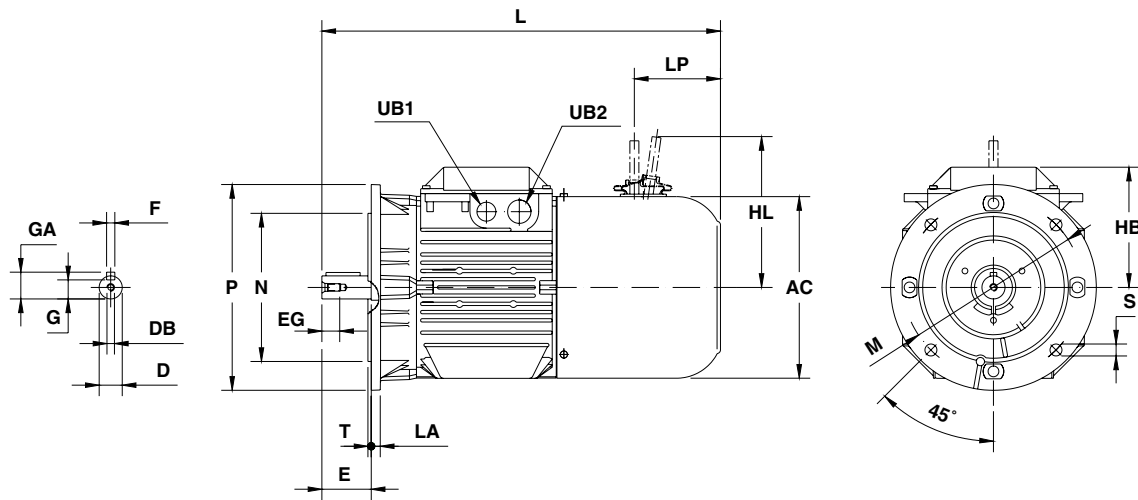

M000136

### IM B5 (IM 3001)

Motor size	AC	D	DB	E	EG	F	GA	HB	HL	L	LP	UB1	UB2
63 A/B	123	11	M4	23	10	4	12.5	117	107	270	66	M16	Pg 11
71	139	14	M5	30	13	5	16	105	114	316	76	M20	Pg 16
80	156	19	M6	40	16	6	21.5	110	124	360	70	M20	Pg16
90S	178	24	M8	50	19	8	27	127	161	370	70	M20	M25
90 L	178	24	M8	50	19	8	27	127	161	395	70	M20	M25
100 L	198	28	M10	60	22	8	31	137	173	453	105	M20	M25
112 M	223	28	M10	60	22	8	31	146	184	487	105	M20	M25
132 S,M	264	38	M12	80	28	10	41	164	225	606	119	M20	M25
160 M,L	317	42	M16	110	36	12	45	209	253	782	139	M40	M40
180	317	48	M16	110	36	14	51.5	209	253	782	139	M40	M40

### IM B5 (IM 3001)

Motor size	IEC flange	LA	M	N	P	S <sup>1)</sup>	T
63 A/B	FF115	10	115	95	140	M8	3
71	FF130	10	130	110	160	M8	3.5
80	FF165	12	165	130	200	M10	3.5
90	FF165	11	165	130	200	M10	3.5
100	FF215	11	215	180	250	M12	4
112	FF215	11	215	180	250	M12	4
132	FF265	12	265	230	300	M12	4
160	FF265	12	265	230	300	M12	4
160 <sup>2)</sup>	FF300	20	300	250	350	M16	5
180	FF300	20	300	250	350	M16	5

### IM B14 (IM 3601)

Motor size	IEC flange	LA	M	N	P	S	T
63 A/B	FT75	10	75	60	90	M5	2.5
71	FT85	10	85	70	105	M6	2.5
80	FT100	10	100	80	120	M6	3
90	FT115	14	115	95	140	M8	3
100	FT130	16	130	110	160	M8	3.5
112 <sup>3)</sup>	FT130	9.5	130	110	160	M8	3.5
132	FT165	14.5	165	130	200	M8	3.5

Tolerances:

D ISO j6 ( $\leq 28 \text{ } \varnothing$ )

D ISO k6 (38-42  $\varnothing$ )

F ISO h9

<sup>1)</sup> Clearance holes for bolt.

<sup>2)</sup> Optional for frame size 160.

<sup>3)</sup> Two pieces modular flange.

Modular flanges:

Brake motors sizes 71-132 can be supplied with several non standard modular flange dimensions

Above table gives the main dimensions in mm.

For detailed drawings please see our web-pages '[www.abb.com/motors&generators](http://www.abb.com/motors&generators)' or contact us.

# General purpose brake motors in brief, basic design

Motor size		63 A/B BB	71	80	90	100	112	132	160	180	
<b>Stator and feet</b>	Material	Die-cast aluminum alloy. Loose feet in sizes 63MA/MB-100 and 180; feet integrated with stator in sizes 63A/B, 112-160.									
	Paint colour shade Paint	Munsell blue 8B 4.5/3.25 / NCS 4822 BO5G / RAL 5014 Exoxy polyester powder paint, $\geq 30 \mu\text{m}$ . 2-pack polyurethane paint, $\geq 20\mu\text{m}$ .									
<b>Bearing end shields</b>	Material	Die-cast aluminum alloy.									
	Paint colour shade Paint	Munsell blue 8B 4.5/3.25 / NCS 4822 BO5G Epoxy polyester powder paint, $\geq 30 \mu\text{m}$ . 2-pack polyurethane paint, $\geq 20\mu\text{m}$									
<b>Flanges</b>	Material	Die-cast aluminum alloy.						Cast iron			
	Paint colour shade Paint	Munsell blue 8B 4.5/3.25 / NCS 4822 BO5G / RAL 5014 Epoxy polyester powder paint, $\geq 30 \mu\text{m}$ . 2-pack polyurethane paint, $\geq 20\mu\text{m}$									
<b>Bearings</b>	D-end	6202- 2Z/C3	6203- 2Z/C3	6204- 2Z/C3	6205- 2Z/C3	6306- 2Z/C3	6206- 2Z/C3	6208- 2Z/C3	6309- 2Z/C3	6310- 2Z/C3	
	N-end	6202- 2Z/C3	6203- 2Z/C3	6204- 2Z/C3	6205- 2Z/C3	6206- 2Z/C3	6206- 2Z/C3	6208- 2Z/C3	6209- 2Z/C3	6209- 2Z/C3	
<b>Axially locked bearings</b>	System	Inner bearing circlip, on request. In sizes 71-80 mounting large flange.			Inner bearing cover at D-end.						
<b>Bearing seals</b>	D-end	V-ring									
	N-end	V-ring									
<b>Lubrication</b>		Permanently lubricated bearings. Grease for bearing temperatures $-40\dots+160^{\circ}\text{C}$ .									
<b>Terminal box</b>	Material Surface treatment Screws	Die-cast aluminum alloy. Similar to stator. Steel 5 G, chromated.									
<b>Connections</b>	Knock-out openings	1 x M16 + Pg11	2xM20 + Pg16		2 x(M25 + M20)		2 x(M25 + M20)		2 x (M40 + M16)		
	Max Cu area, mm <sup>2</sup>	2.5	4		6		10		35		
	Terminal box	Screw terminal, 6 terminals.					Cable lugs, 6 terminals.				
<b>Fan</b>	Material	Polypropylene. Reinforced with 20% glass fibre.									
<b>Fan cover</b>	Material	Steel.									
<b>Stator winding</b>	Material Impregnation Insulation class	Copper. Polyester varnish. Tropicalised. Insulation class F. Temperature rise class B, unless otherwise stated.									
<b>Stator winding temperature sensors</b>		Optional.									
<b>Rotor winding</b>	Material	Die-cast aluminum.									
<b>Balancing method</b>		Half key balancing.									
<b>Key ways</b>		Closed key way.									
<b>Enclosure</b>		Motor, terminal box and brake electrical components: IP 55. Brake mechanical components: IP23 S (IP 55 optional).									
<b>Cooling method</b>		IC 411									





# ABB Motors' total product offer

ABB offers several comprehensive ranges of AC motors and generators. We manufacture synchronous motors for even the most demanding applications, and a full range of low and high voltage induction motors. Our in-depth knowledge of virtually every type of industrial processing ensures we always specify the best solution for your needs.



M1000328

## Low voltage motors and generators

### Process performance motors formore demanding applica- tions

- Cast iron motors
- Premium efficiency motors
- NEMA motors

### Industrial performance motors - flexibility for most customer applications

- Aluminum motors
- Steel motors
- Cast iron motors

### General performance motors - out-of-the-box simplicity for highvolume customers

- Aluminum motors
- Cast iron motors

### Motors for hazardous areas

- Flameproof motors
- Increased safety motors
- Non-sparking motors
- Dust ignition proof motors

### Marine motors

- Aluminum motors
- Steel motors
- Cast iron motors
- Open drip proof motors

### Other applications

- Open drip proof motors
- Global motors
- Brake motors
- Single phase motors
- High ambient motors
- Permanent magnet motors
- High speed motors
- Wind turbine generators
- Smoke venting motors
- Water cooled motors
- Motors for roller table drives
- Servomotors

## High voltage and synchronous motors and generators

- High voltage cast iron motors
- Induction modular motors
- Slip ring motors
- Motors for hazardous areas

- Synchronous motors and generators
- DC motors and generators
- Wind turbine generators
- Traction motors

# Visit our web site

www.abb.com/motors&generators

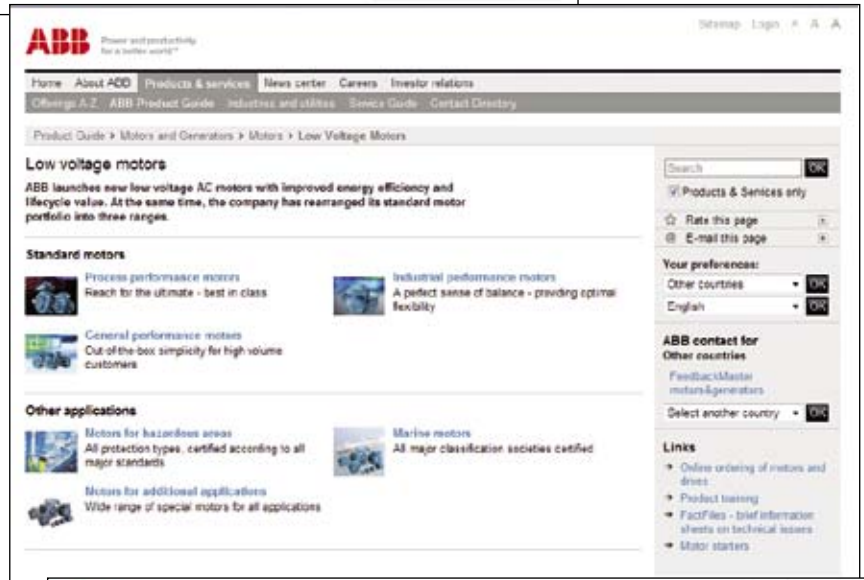
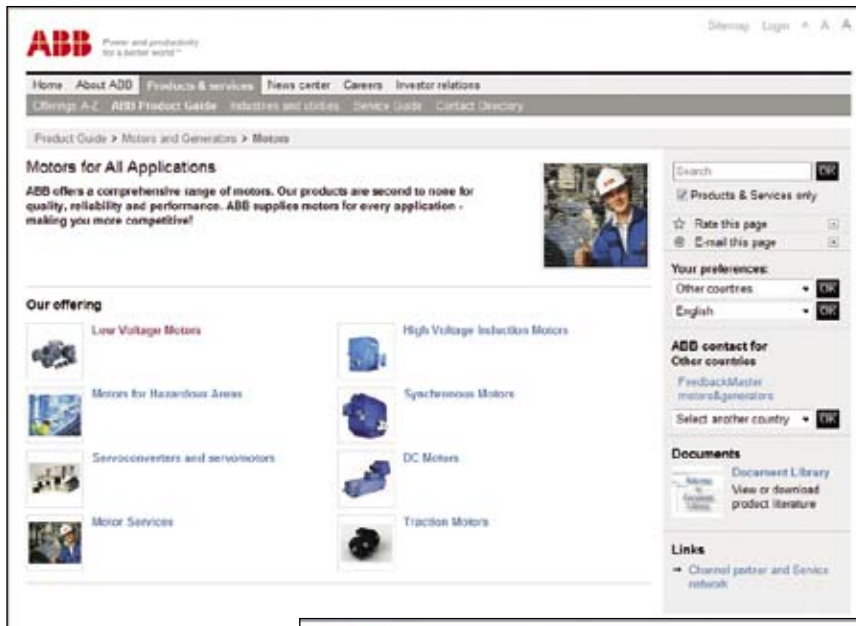

## Motors & Generators

### > Motors

#### >>> Low Voltage Motors

Process performance motors  
Industrial performance motors

#### >>>> General performance motors

>>>>> New aluminum motors  
>>>>> Aluminum motors  
>>>>> Cast iron motors  
General performance motors  
Motors for hazardous areas  
Marine motors  
Motors for additional applications

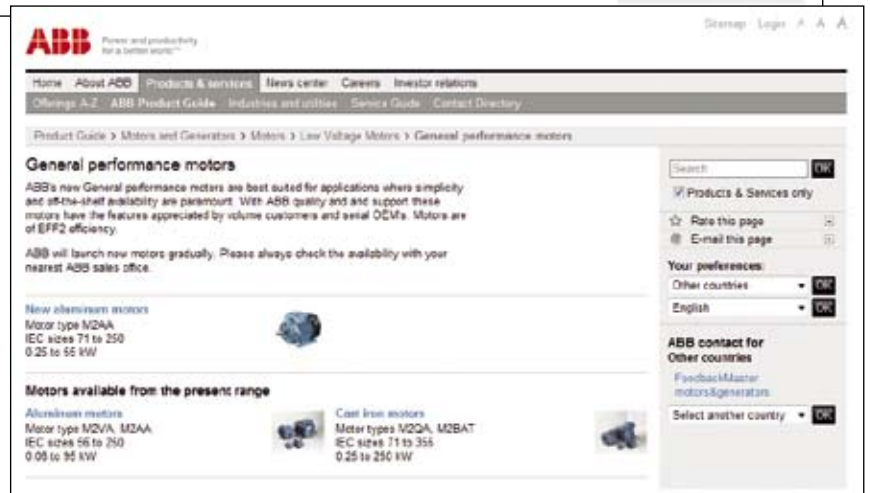

# Low Voltage Motors

Manufacturing sites (\*) and some of the larger sales companies.

## Australia

ABB Australia Pty Ltd  
601 Blackburn Road  
Notting Hill VIC 3168  
Tel: +61 (0) 8544 0000  
Fax: +61 (0) 8544 0001

## Austria

ABB AG  
Clemens Holzmeisterstrasse 4  
A-1109 Wien  
Tel: +43 (0) 1 601 090  
Fax: +43 (0) 1 601 09 8305

## Belgium

Asea Brown Boveri S.A.-N.V.  
Hoge Wei 27  
BE-1930 Zaventem  
Tel: +32 (0) 2 718 6311  
Fax: +32 (0) 2 718 6657

## Canada

ABB Inc., BA Electrical Machines  
10300 Henri-Bourassa Blvd, West,  
Saint-Laurent, Quebec  
Canada H4S 1N6  
Tel: +1 514 832-6583  
Fax: +1 514 332-0609

## China\*

ABB Shanghai Motors Co., Ltd.  
88 Tianning Road  
Minhang(Economical and Techno-  
logical Development Zone)  
200245 Shanghai  
Tel: +86 21 5472 3133  
Fax: +86 21 5472 5025

## Chile

Asea Brown Boveri S.A.  
P.O.Box 581-3  
Santiago  
Tel: +56 (0) 2 5447 100  
Fax: +56 (0) 2 5447 405

## Denmark

ABB A/S  
Automation Products  
Emil Neckelmanns Vej 14  
DK-5220 Odense SØ  
Tel: +45 65 47 70 70  
Fax: +45 65 47 77 13

## Finland\*

ABB Oy  
Motors  
P.O.Box 633  
FI-65101 Vaasa  
Tel: +358 (0) 10 22 11  
Fax: +358 (0) 10 22 47372

## France

ABB Entelec  
ZA La Boisse BP 90145  
300 Rue des Prés-Seigneurs  
FR-01124 Montluel Cedex  
Tel: +33 4 37 40 40 00  
Fax: +33 4 37 40 40 72

## Germany

ABB Automation Products GmbH  
Motors & Drives  
Wallstaedter Strasse 59  
DE-68526 Ladenburg  
Tel: +49 (0) 6203 717 717  
Fax: +49 (0) 6203 717 600

## Hong Kong

ABB (Hong Kong) Ltd.  
Tai Po Industrial Estate,  
3 Dai Hei Street,  
Tai Po, New Territories,  
Hong Kong  
Tel: +852 2929 3838  
Fax: +852 2929 3505

## India\*

ABB Ltd.  
32, Industrial Area, N.I.T  
Fariabad 121 001  
Tel: +91 (0) 129 502 3001  
Fax: +91 (0) 129 502 3006

## Indonesia

PT. ABB Sakti Industri  
JL. Gajah Tunggal Km.1  
Jatiuwung, Tangerang 15136  
Banten, Indonesia  
Tel: + 62 21 590 9955  
Fax: + 62 21 590 0115 - 6

## Ireland

Asea Brown Boveri Ltd  
Components Division  
Belgard Road  
Tallaght, Dublin 24  
Tel: +353 (0) 1 405 7300  
Fax: +353 (0) 1 405 7327

## Italy\*

ABB SACE SpA  
LV Motors  
Via dell' Industria 18  
IT-20010 Vittuone, Milano  
Tel: +39 02 90341  
Fax: +39 02 9034 7289

## Japan

ABB K.K.  
26-1 Cerulean Tower  
Sakuragaoka-cho, Shibuya-ku  
Tokyo 150-8512  
Tel: +81 (0) 3 578 46251  
Fax: +81 (0) 3 578 46260

## Korea

ABB Korea Ltd.  
7-9fl, Oksan Bldg., 157-33  
Sungshung-dong, Kangnam-ku  
Seoul  
Tel: +82 2 528 2329  
Fax: +82 2 528 2338

## Malaysia

ABB Malaysia Sdn. Bhd.  
Lot 608, Jalan SS 13/1K  
47500 Subang Jaya, Selangor  
Tel: +60 3 5628 4888  
Fax: +60 3 5631 2926

## Mexico

ABB México, S.A. de C.V.  
Apartado Postal 111  
CP 54000 Tlalnepantla  
Edo. de México, México  
Tel: +52 5 328 1400  
Fax: +52 5 390 3720

## The Netherlands

ABB B.V.  
Dept. LV motors (APP2R)  
P.O.Box 301  
NL-3000 AH Rotterdam  
Tel: +31 (0) 10 4078 879  
Fax: +31 (0) 10 4078 345

## Norway

ABB AS  
P.O.Box 154 Vollebekk  
NO-0520 Oslo  
Tel: +47 22 872 000  
Fax: +47 22 872 541

## Russia

ABB Industrial & Building Systems  
Ltd.  
Business Centre "Krugozor"  
Obrucheva 30/1, Building 2  
Moscow 117861  
Tel: +7 495 960 2200, 956 93 93  
Fax: +7 495 960 2209, 230 63 46

## Singapore

ABB Industry Pte Ltd  
2 Ayer Rajah Crescent  
Singapore 139935  
Tel: +65 6776 5711  
Fax: +65 6778 0222

## Spain\*

Asea Brown Boveri S.A.  
Automation Products - Fábrica  
Motores  
P.O.Box 81  
ES-08200 Sabadell  
Tel: +34 93 728 8500  
Fax: +34 93 728 8741

## Sweden\*

ABB AB  
LV Motors  
SE-721 70 Västerås  
Tel: +46 (0) 21 329 000  
Fax: +46 (0) 21 329 140

## Switzerland

ABB Schweiz AG  
Normelec/CMC Components  
Motors&Drives  
Badenerstrasse 790  
Postfach  
CH-8048 Zürich  
Tel: +41 (0) 58 586 0000  
Fax: +41 (0) 58 586 0603

## Taiwan

ABB Ltd.  
6F, No. 126, Nanking East Road,  
Section 4i  
Taipei, 105 Taiwan, R.O.C.  
Tel: +886 (0) 2 2577 6090  
Fax: +886 (0) 2 2577 9467

## Thailand

ABB Limited (Thailand)  
161/1 SG Tower,  
Soi Mahadlekluang 3,  
Rajdamri, Bangkok 10330  
Tel: +66 2 665 1000  
Fax: +66 2 665 1042

## The United Kingdom

ABB Ltd  
Drives, Motors and Machines  
Daresbury Park  
Daresbury, Warrington  
Cheshire, WA4 4BT  
Tel: +44 (0) 1925 741 111  
Fax: +44 (0) 1925 741 212

## USA

ABB Inc.  
Low Voltage Motors  
16250 W. Glendale Drive  
New Berlin, WI 53151  
Tel: +1 262 785 3200  
Fax: +1 262 780 8888

## Venezuela

Asea Brown Boveri S.A.  
P.O.Box 6649  
Carmelitas,  
Caracas 1010A  
Tel: +58 (0) 2 238 2422  
Fax: +58 (0) 2 239 6383



www.abb.com/motors&generators  
http://online.abb.com/bol