

# PDC-6000

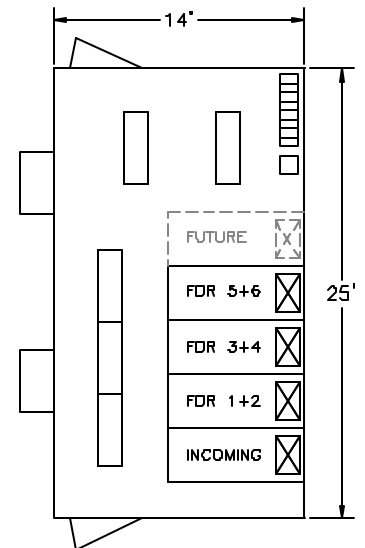

The PDC-6000 is a prefabricated modular, skid-mounted enclosure for switchgear and auxiliary equipment. As a self-contained unit, it is completely coordinated, assembled and tested in controlled factory environment. With integral transformers, close-coupled to switchgear or with bus duct connections, a PDC-6000 can serve as a complete unit substation

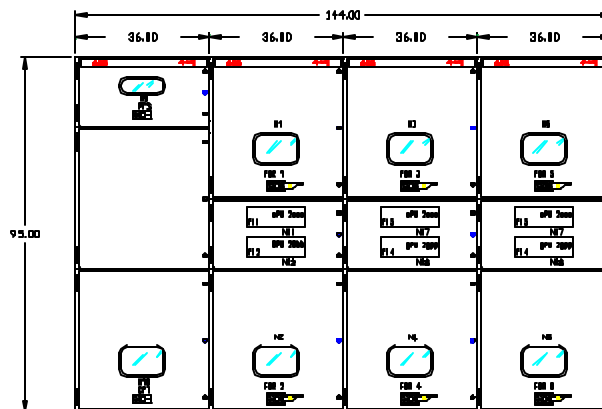
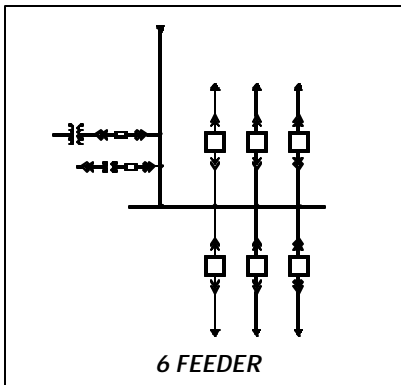

## Key advantages of the PDC concept

- Single source responsibility, coordination, and accountability for a complete system
- Reduced installation and ownership costs
- Application flexibility



WITH ABB PDCs, YOU GET THE BEST  
IN SWITCHGEAR TECHNOLOGY...WITHOUT COMPROMISE

## PDC BUILDING

## SWITCHGEAR

### Materials and Construction

The base shall be constructed of a welded structural steel frame and floor plate, thickness at least 0.25" (8mm). The PDC shall be equipped with lifting lugs. The outer roof shall be sloped. All panels shall be double wall construction with interlocking seams. All exterior seams shall be gasketed or caulked.

The PDC shall be equipped with a personnel entrance door at each end. The PDC shall have a front aisle of at least 72-inches width.

All PDC utilities shall be UL listed. Interior lighting shall consist of ceiling-mounted fluorescent fixtures, with 3 way switches located near each personnel entrance door. Wall-mounted duplex receptacles at each personnel entrance door.

Rear access to the switchgear shall be through hinged removable doors with padlock provisions, located directly behind each switchgear frame.

### Finish

All interior and exterior surfaces shall be primed before application of the finish coat. Interior and exterior colors shall be as specified on project data sheets. The floor shall have a finish coat of ANSI 61, gray polyurethane enamel, with a non-skid additive.

### Cable Entry and Equipment Connections

Bus duct or cable entry provisions shall be provided as required for power transformers and other equipment. An opening shall be provided under each switchgear frame for conduit access. Covers shall be supplied for all floor openings.

### Standard Design Criteria

Area Classification - General Purpose Non-Hazardous  
 40 Roof Load - Uniform Building Code 1997  
 90 Wind Load - Uniform Building Code 1997  
 250 Floor Loading - DL+LL in psf  
 1 Base Deflection - L/240 (On Foundation)  
 2A Seismic Zone - Uniform Building Code 1997  
 50fc Lighting Level - @ Floor

### Materials and Construction

SafeGear and Advance metal-clad switchgear shall be of modular construction, fabricated primarily from 14-gauge Galalume® material (zinc aluminum coated, cold-rolled carbon steel). Double sidewall construction with integral air-gap shall be utilized throughout.

### Circuit Breaker

The ADVAC circuit breaker shall be a 3-pole drawout type, vacuum circuit breaker, electrically operated, with electric motor and manual charging of a spring type stored energy operating mechanism. The breaker is a general-purpose device in accordance with applicable ANSI/IEEE standards in ratings of 1200 A, 2000 A and 3000 A.

### Bus Bars and Supports

Bus bars shall be made of copper with full rounded edges. Primary bus conductors shall be epoxy insulated, except at bolted joints. Bus joint covers are shall be reusable for field inspection and maintenance.

### Ground Bus

A tin-plated copper ground bus, to which the entire metallic enclosure is solidly connected, shall extend through the length of the switchgear. The ground bus shall be accessible in the cable compartment and shall have connection points in each switchgear section.

### Current Transformers

CT ratings and accuracy shall be in accordance with ANSI/IEEE, C57.13 and C37.20.2.

### Potential Transformers and Control Power Transformers

Potential transformers and Control Power transformers shall be drawout type with ratings and accuracy in accordance with ANSI C57.13. PT's and CPT's shall be fused. Drawout units shall use the same racking system, accessories and solid grounding as the circuit breakers but without a Test position. All primary contacts of auxiliary draw-out units shall be of the arc-extinguishing probe type. This contact shall minimize and suppress arcing at the primary contacts.

### Protection and Control

Multifunction relays are used to provide basic overcurrent protection and current metering functions for all circuits. Control switches and indicating lights are also included. Additional protection and metering functions may be added for a nominal charge.