

PowerCube PB6 (36kV)

*Installation and maintenance instructions for
air insulated MV modules*



This Manual contains general information for receiving, installation, commissioning, operation, and maintenance of **PowerCube PB6** Modules

Information should be considered together with:

Installation and maintenance instructions, **PowerCube**
ABB doc: ITNIE647652/001

Installation and maintenance instructions, HD4
ABB doc: ITNIE647016/003





FOR YOUR SAFETY

- Make sure that the room is suitable for the installation of electrical apparatus and enclosures.
- Make sure that all the installation, putting into service and maintenance operations are carried out by skilled personnel with in-depth knowledge of the apparatus.
- Make sure that all the installation, service and maintenance operations comply with standard and legal requirements for constructing the installations in accordance with the regulations for safety in the workplace.
- Strictly follow this instruction manual.
- Make sure that the ratings are not exceeded while the apparatus is in service.
- Pay the utmost attention to the notes shown in the manual by the following symbol: 
- Make sure that the personnel working on the apparatus have this manual to hand and all the information required for correct intervention.
- Responsible behaviour safeguards your own and others' safety!
- For any requests, place contact the ABB Assistance Service.

CONTENTS

1	Packing and Transport.....	3
2	Control on receipt.....	3
3	Storage.....	3
4	Handling.....	3
5	Description.....	3
6	operation.....	6
6.1	Earthing Switch.....	6
6.2	Circuit Breaker.....	7
6.3	Withdrawable voltage transformer.....	8
7	Fuse replacement.....	8
8	Installation.....	9
8.1	Foundation.....	9
8.2	Main circuit connection, branch version.....	10
8.3	Main circuit connection, terminal version.....	11
8.4	Earth main circuit connection.....	12
9	Putting into service.....	12
10	Periodic checks.....	12
11	Maintenance Operations.....	12
12	Accessories and spare parts.....	12

1 PACKING AND TRANSPORT

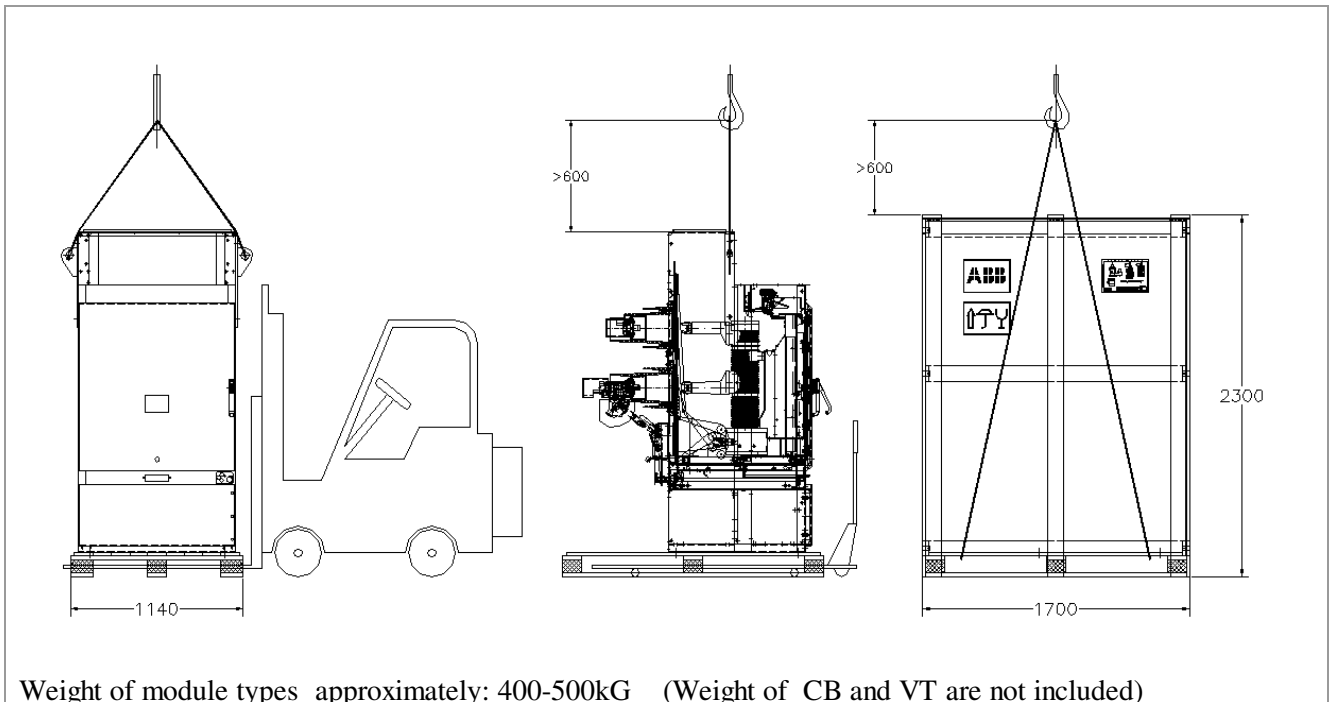

2 CONTROL ON RECEIPT

3 STORAGE

4 HANDLING

Refer to chapt:1,2,3,4 of “PowerCube Installation and maintenance instructions”

5 DESCRIPTION

The PowerCube modules allow MV metal-clad switchboards with metal enclosure to be built, suitable for indoor installation.

The PowerCube modules are pre-assembled and tested in the factory.

The PowerCube modules are suitable for all primary distribution requirements with service voltages up to 36 kV and can take on different configurations according to customer requests.

For the instructions regarding the apparatus and REF 542 Plus protection and control unit, please refer to the relative manuals.

All normal service operations are carried out from the front of the module with the doors closed. The doors on the front only need to be opened for maintenance operations and replacement of spare parts.

The circuit-breaker unit can be fitted with withdrawable circuit-breakers or voltage transformers.

The PowerCube modules can be installed against walls since they are fully accessible from the front for the operations, maintenance and installation operations.

The PowerCube modules allow arc-proof switchboards to be constructed in compliance with the prescriptions of the IEC

60298 - App. AA Standards, class of access (A) criteria (1 - 6).

The PowerCube modules allow to design with the following degrees of protection:

Degree of protection with doors open IP2X

Degree of protection on the external enclosure IP4X

As complementary, please refer to chapt:5 of “PowerCube Installation and maintenance instructions”

Typical sectional view

Version with branches (p.c.d. of busbar connections 360-400 mm)

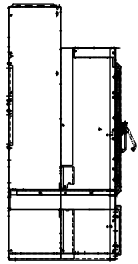
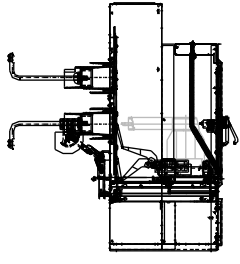
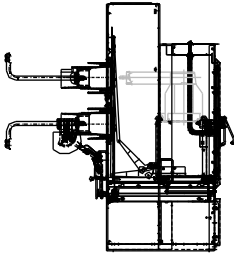
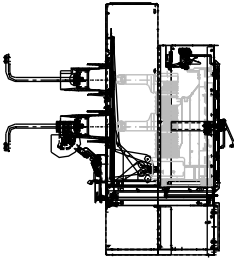
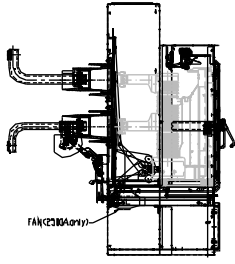
				
Module for: Busriser (dummy fore- part)	Module for: V.T. lower circuit / Earthing / Busriser	Module for: V.T. upper circuit / Earthing / Busriser Dim.dwg: 1YTW571790-158	Module for C.B. HD4W 36 630-1250A Dim.dwg: 1YTW571790-157	Module for C.B. HD4W 36 1600-2000-2500A Dim.dwg: 1YTW571790-159

Dimensional drawings available on request in electronic format.

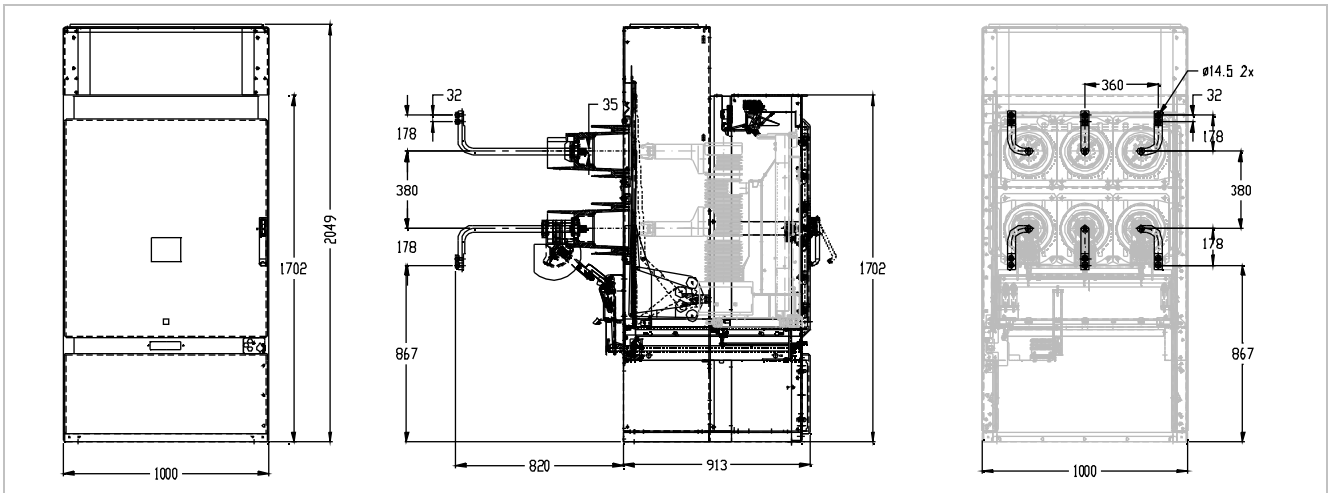

Dimensions summary , Modules for VT and C.B. HD4W 630-1250A

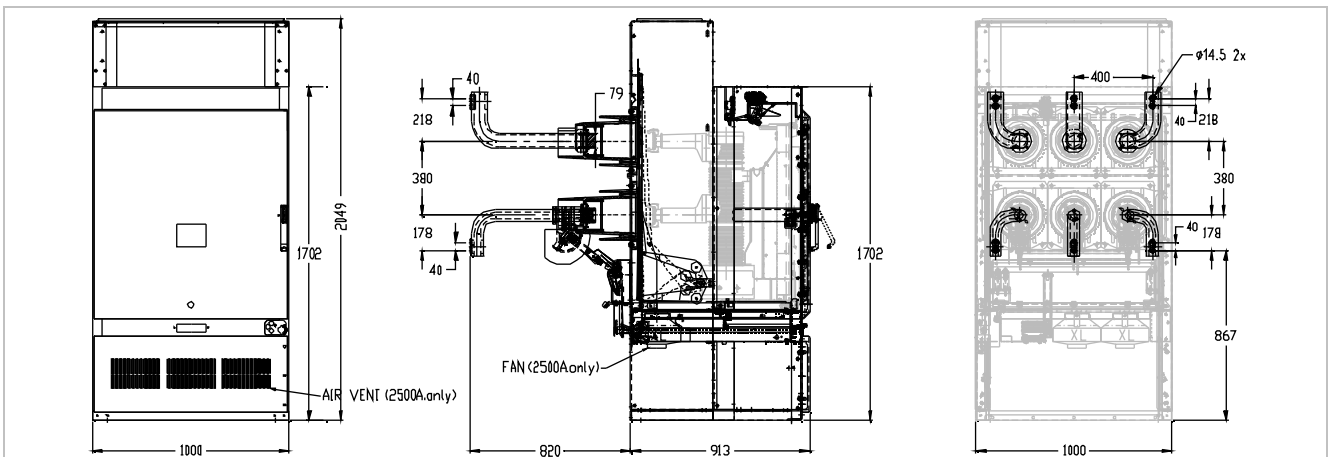

Dimensions summary , Modules for C.B. HD4W 1600-2000A and 2500A(with fan)

6 OPERATION

6.1 Earthing Switch



CAUTION! Earthing switch must not be attempted for operation when it is possible that a personnel may be in the cubicle.

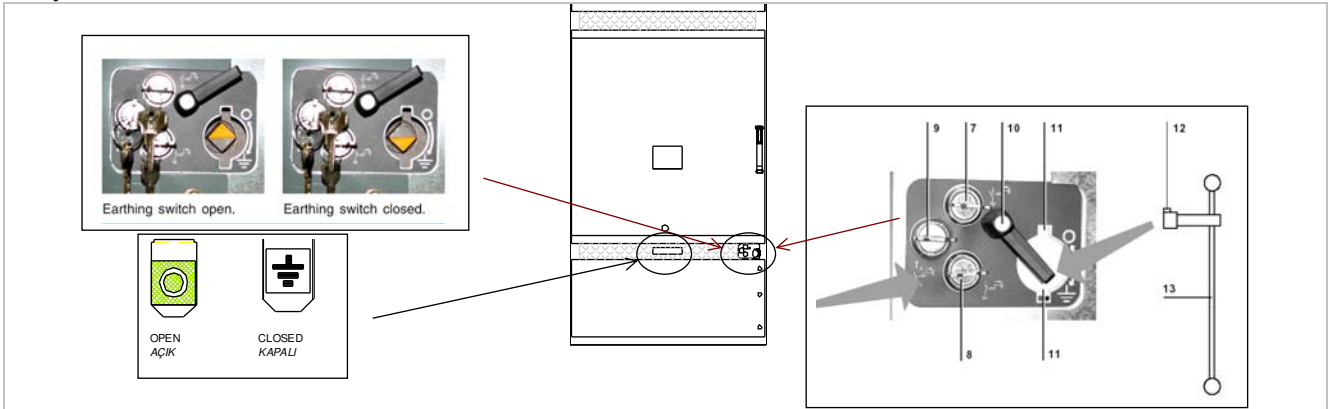

- 7: Key lock*for ESw at open position
- 8: Key lock* for ESw at closed (earthed) position
- 9: Key lock* to prevent CB racking-in
- 10: Handle to open entrance for operating lever
- 11:Cover of entrance for operating lever
- 12+13: Esw operating lever (Art.No: 143429-802)



electro magnetic interlock for earthing switch



Esw in open position

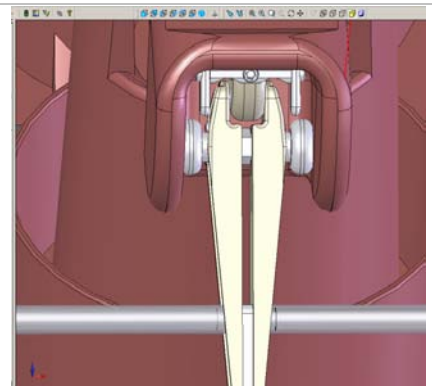

Esw contacts closed, view from bottom

6.2 Circuit Breaker



RACKING HD4 BREAKER INTO SERVICE POSITION

- 1 Place the breaker onto the CB trolley
- 2 Open the CB compartment door .
- 3 Check that CB compartment is ready, (no foreign objects etc)
- 4 Place the trolley in position in front of the cubicle and hoist it to same level as the rail in the cubicle. Fold the bridgepart and make sure it is flat and locks in the cubicle.
- 5 Push the breaker into the cubicle.
- 6 Remove the CB trolley.
- 7 Check the handles on racking mech are released and lock the CB to the rails in the cubicle.
- 8 Connect the multipole contact for the auxiliary circuits. (Attention: The multipole connector fits only if the rating of CB fits the rating of cubicle)
- 9 Check that:
the springs are being loaded if they were not.
- 10 Close the door.
- 11 Open the earth switch, remove the ESw handle,close the ESw crank cover(11)



CAUTION! For safety reason all racking and operation of the breaker shall be done behind the closed door.

- 12 Crank the breaker racking mechanism **clockwise** without stopping until completely engaged, The travel distance is of CB is 300 mm. At the last 30mm while the main contacts engage, the resistance will increase. Continue the racking until related limit switches signal, picture below. (ElectroMech interlocking YL2 blocks the racking when control voltage is not available.
- 13 Check that you read and comply with the C.B. instruction manual (ABB doc: ITNIE647016/003) also...
The breaker is now prepared to operate.

For the 2500A CB module the air ventilation fans should be switched on when the continuous current exceeds 2000A .

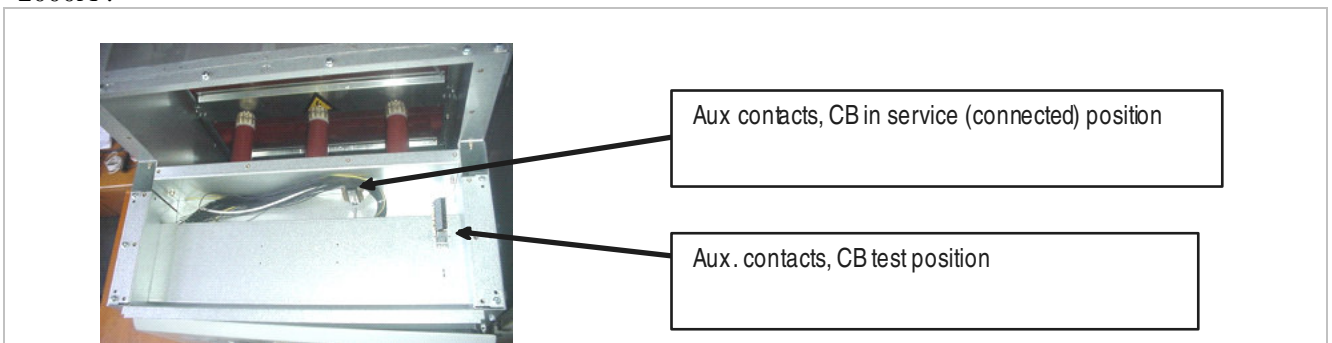

6.3 Withdrawable voltage transformer

The withdrawable fused VT units in 36kV need a dedicated module as the C.B.



CAUTION! For safety reasons VT-racking shall be done behind the closed door.

CAUTION! The voltage transformers must not be accessible while they are in connected position.

The compartment door of the voltage transformer should be locked by pad-lock so that only authorized maintenance personnel can open.



As complementary, refer to chapt:6 of “PowerBox Installation and maintenance instructions

7 FUSE REPLACEMENT

The V.T. can be inserted for service and withdrawn for maintenance with sequence similar to CB.

The CB trolley is compatible with the withdrawable V.T.’s.

As complementary, refer to chapt:7 of “PowerCube Installation and maintenance instructions and the fused V.T. catalogue.

8 INSTALLATION
8.1 Foundation

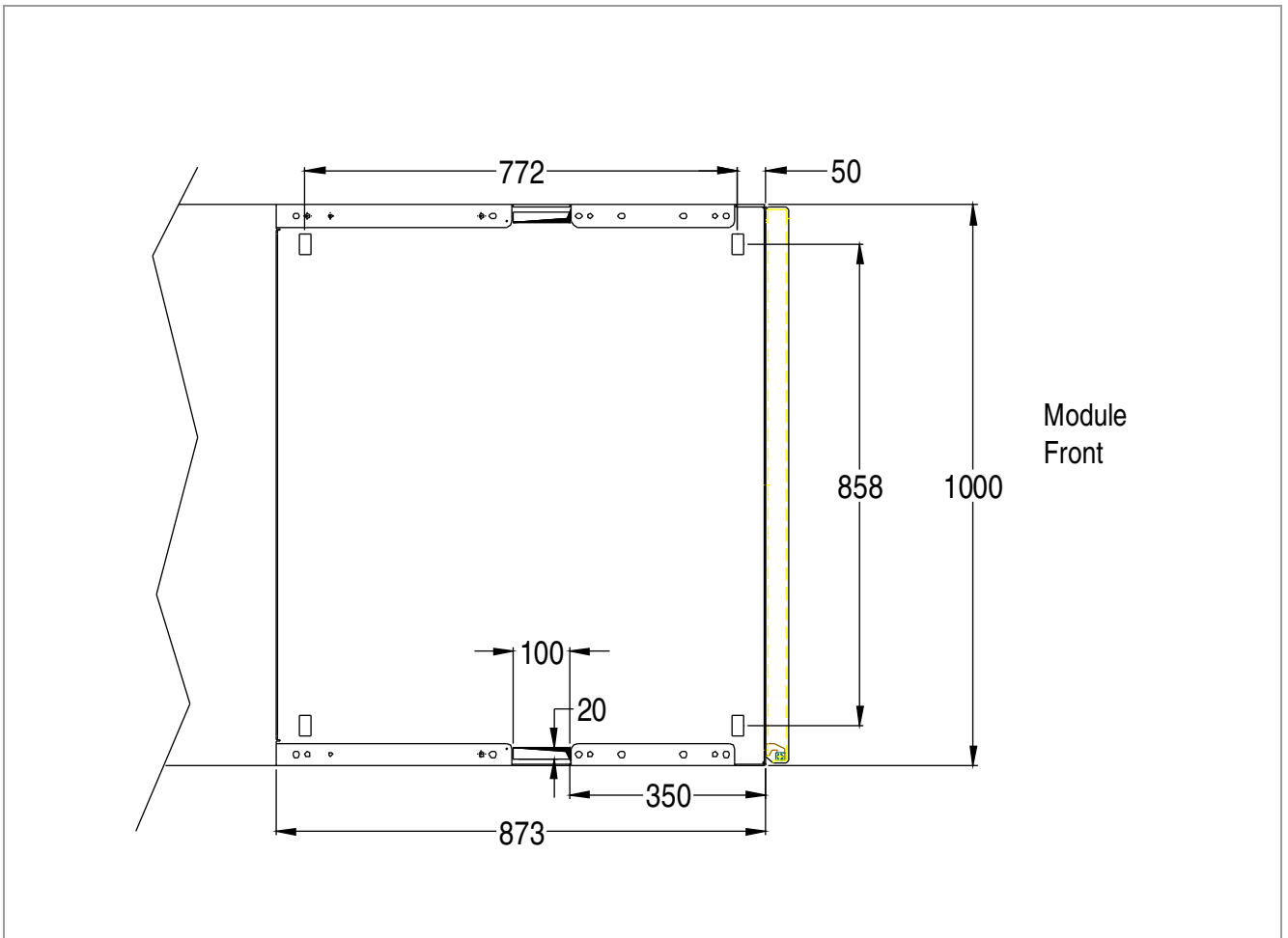

Above: Bottom plate dimensions dwg. as input for the foundation plan.
 For the “installation conditions” “foundations” “module fixing systems” refer to chapt:8 of “PowerCube Installation and maintenance instructions”

8.2 Main circuit connection, branch version

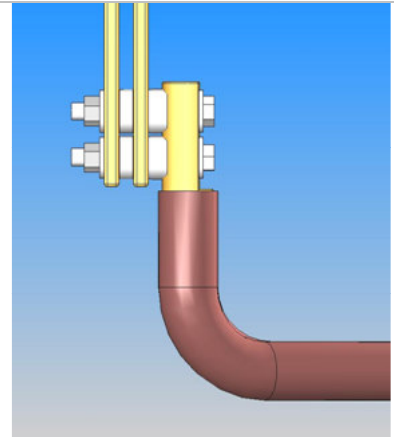
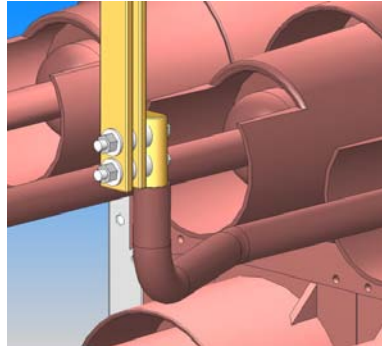
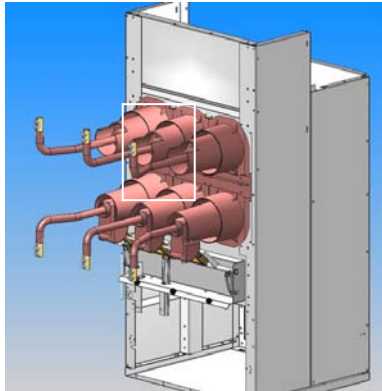

Fig:8.2.1

CB module:branch version 1250A

Connected busbars in typical view above: 2x40x10mm Cu

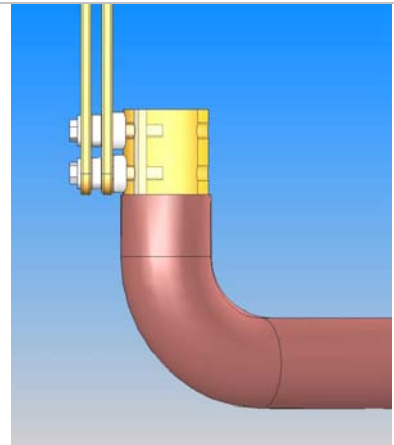
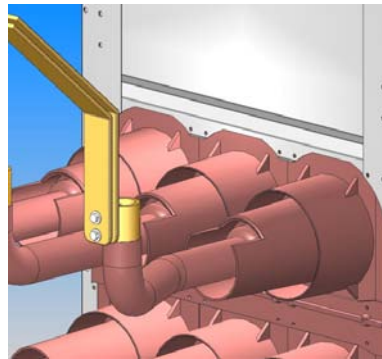
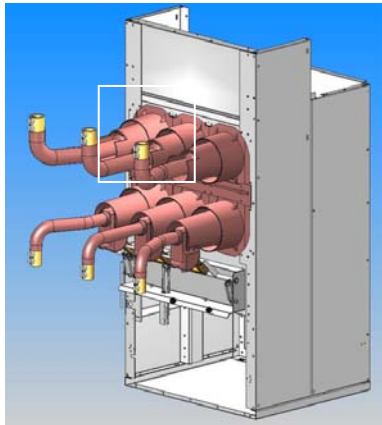

Fig:8.2.2

CB module:branch version
1600-2000-2500A

Connected busbars in typical view above: 2x80x10mm Cu

For main circuit connections :

Assure cleaning of conducting surfaces before final tightening,

Support the busbars against rotation forces,

Use bolts and nuts of min.8.8 property class steel and Conical spring-steel washers DIN 6796,

M12 Tightening torque 70 (-0+20%) Nm.

For the tightenings where threaded side are inserted in or directly supported by epoxy-casted bushings it is advised to apply reduced tightening torque by greasing the thread and bolt head contact surface.

Tightening torques OILED OR GREASED: (-0+20%)

M12: 40Nm

M10: 20Nm

M8: 10Nm

8.3 Main circuit connection, terminal version

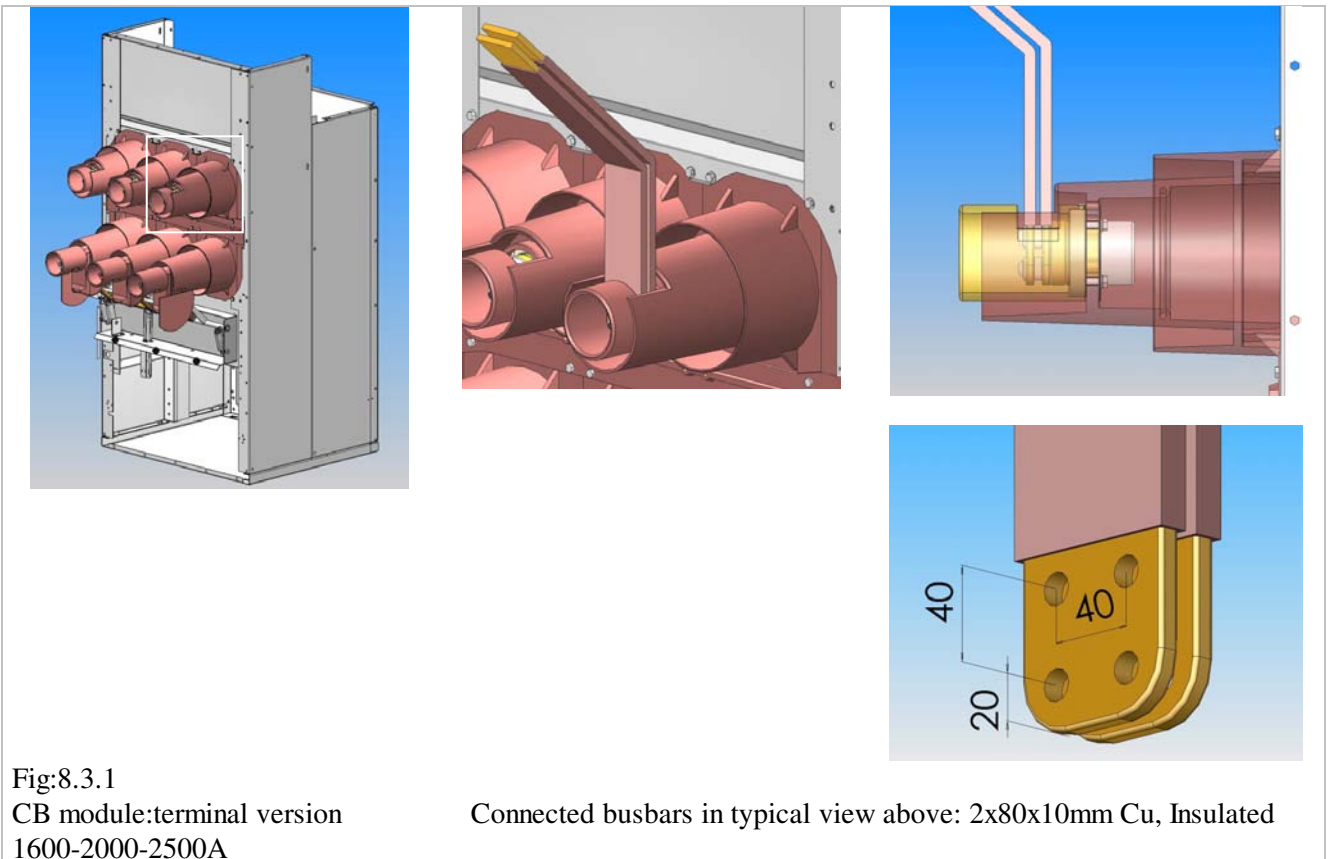
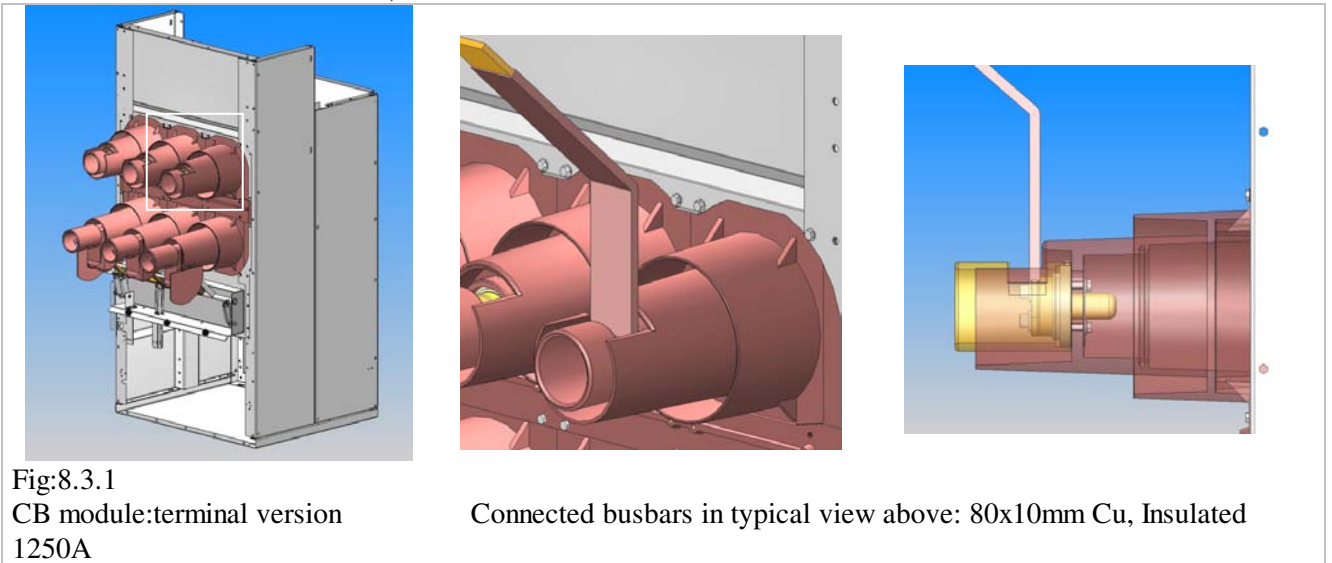

Assembly drawings available on request in electronic format.

8.4 Earth main circuit connection

Location of main earth circuit terminal , see photo below

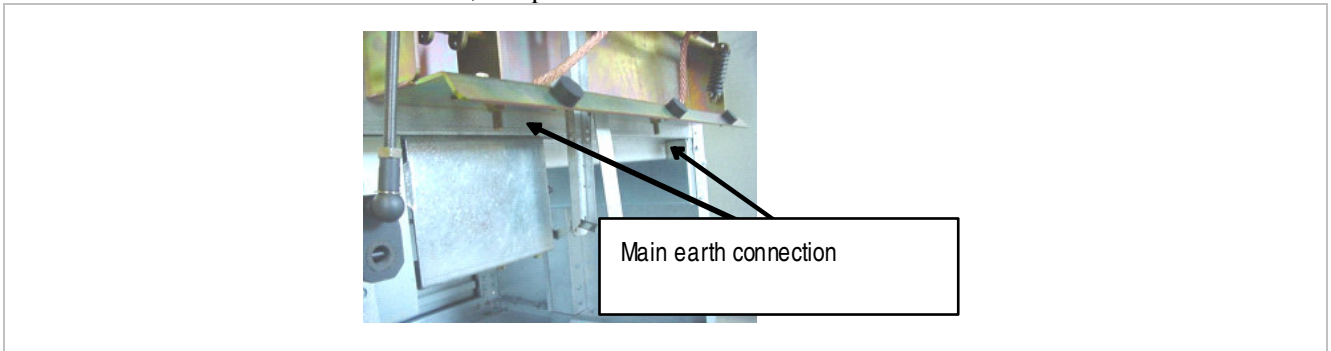

Design guide for lower busbars / earthing circuit , typical direction of current flow should be as below figure for rated short circuit withstand and making performance of earthing switch.

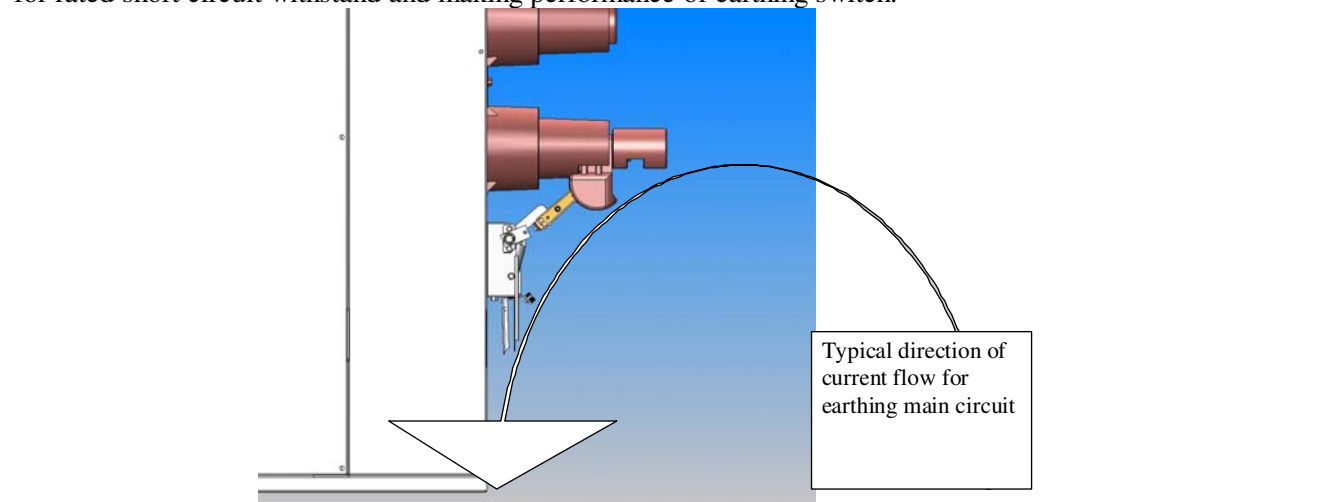

9 PUTTING INTO SERVICE

Refer to chapt:9 of “PowerCube Installation and maintenance instructions”

10 PERIODIC CHECKS

Refer to chapt:10 of “PowerCube Installation and maintenance instructions”

11 MAINTENANCE OPERATIONS

Refer to chapt:11 of “PowerCube Installation and maintenance instructions”

12 ACCESSORIES AND SPARE PARTS

Refer to chapt:12 of “PowerCube Installation and maintenance instructions”

This manual is continuously updated and we would appreciate user's view regarding the contents of this manual, please notify:



ABB Elektrik Sanayi A.S.
Organize Sanayi Bölgesi
2.Cadde No. 16 Yukari Dudullu
34776 Istanbul Turkey
Phone no: +90 216 5282200
Fax no: +90 216 3652943

Web site://www.abb.com

The data and illustrations are not binding. We reserve the right to make changes in the course of technical development of the product.