

Bushing Combi Sensors



Sensors - New detectors in medium voltage system

General

Conventional instrument transformers have been widely used in medium voltage networks for transforming high currents and voltages to a level suitable for measuring and protection. The instrument transformers have been dimensioned according to the requirements of the measuring equipment and protection relays.

The introduction of new digital technology for measuring and protection in medium voltage system has changed the demands of the detectors.

The level of the input signal to the new measuring and protection system has been significantly reduced compared to the level for conventional systems. Due to this ABB has introduced a range of sensors. The sensors fulfil in an optimal way the requirements of the different functions in the new digital secondary equipment.

Technical benefits

Extensive dynamic range

In medium voltage systems upto 24 kV, it is possible, with only one type to cover the whole scope of current and voltage sensors for measuring and protection.

Non-saturable

No ferromagnetic cores are used in the sensors. This means that the sensors are immune to any risk of saturation and are linear over the whole measuring range.

High degree of accuracy

The sensors are designed for the smaller power requirements of digital secondary equipment. Instead of a typical burden of a conventional transformer, 15 VA and more, the sensor delivers the signal with a burden of only a fraction of a VA.

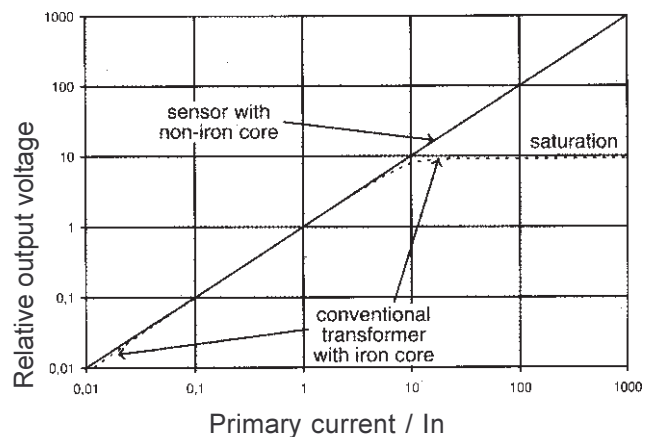

Economical benefits

Small in volume and weight

The sensors are much smaller in volume and weight compared to conventional instrument transformers. These benefits are used to full advantage in new constructions of medium voltage switchgear.

Simplified engineering and logistics

As mentioned above the sensors have an extensive dynamic range compared to conventional instrument transformers. Due on this only one type of sensors is needed. This means that we can offer very simple engineering and logistics.

Environmentally friendly technology

The construction of the sensors means that much less raw material is needed. This means that the sensors are a step into more environmentally friendly technology.

Description

The current sensor is based on the principle of the Rogowski-coil. The sensor consists of an air-core winding, immune to any risk of saturation as it has no ferromagnetic core. It is linear over the whole measuring range. The output signal is a voltage, which is proportional to the derivative of the current. A digital integration of this voltage is carried out and gives the measured current.

The voltage sensor is based on the capacitive voltage divider. Also this sensor is non-saturable and linear over the whole measuring range. The output signal is a voltage, which is directly proportional to the primary voltage.

A coupling capacitor is included.

Type

Bushing Combi Sensor, type KEVCY 24 AE1.

Technical Data

Current Sensor

Primary current	upto 1250 A
Rated output voltage	150 mV (50 Hz)
Rated frequency	50, 60 Hz
Temperature range	-40....+70 °C
Accuracy	Class 1
Short circuit Withstand current	31,5 / 80 kA

Voltage Sensor

Rated voltage	upto 24 kV
Insulation level	50 / 125 kV
Division ratio	10.000 / 1
Rated frequency	50, 60 Hz
Temperature range	-40....+70 °C
Accuracy	Class 3 / 3P
Weight	9.0 kg

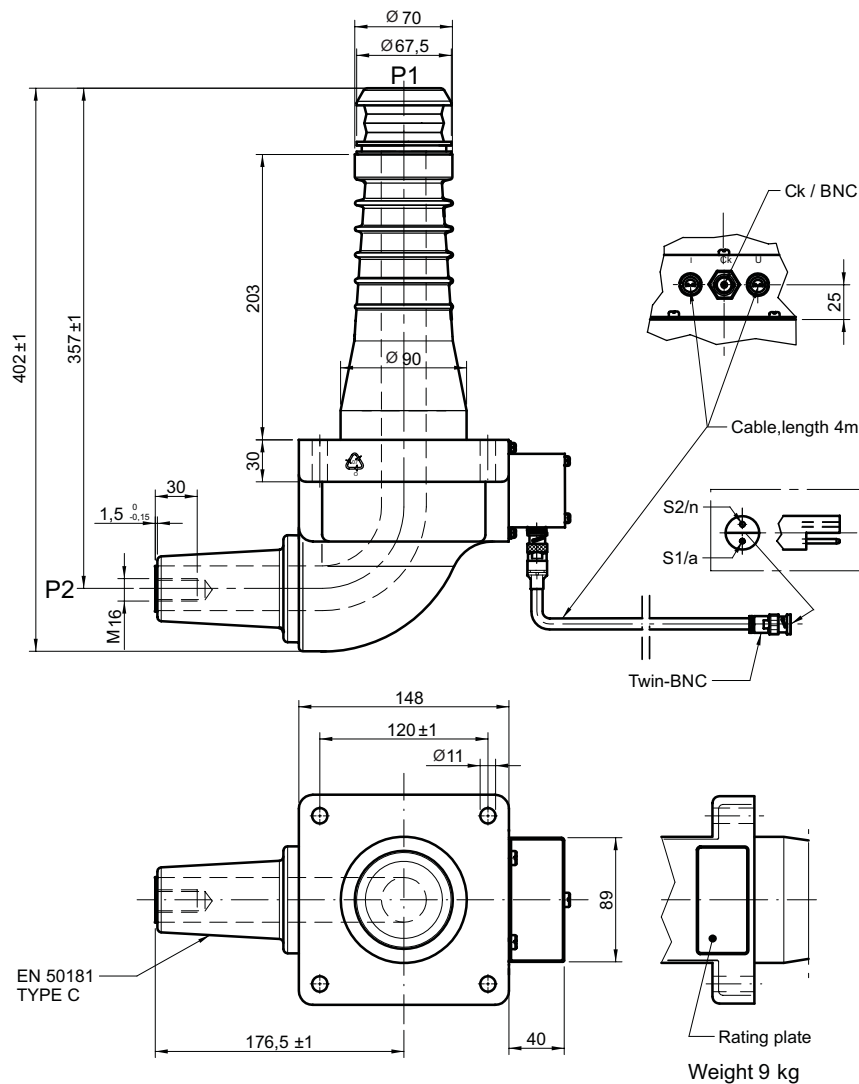

Length of cable 4.0 m

Dimension drawing, 135 KEVCY 1



ABB Oy
Medium Voltage Technology
P.O.Box 613, FIN-65101 Vaasa, Finland
Tel: +358 10 22 4000
Fax: +358 10 22 42616