

VersaRupter Family

INSTALLATION/MAINTENANCE INSTRUCTIONS



TABLE OF CONTENTS

	Page
INTRODUCTION	
Application.....	4
Receiving, Handling and Storage.....	4
OPERATING FEATURES AND FUNCTION	
OPERATING MECHANISM	4
K-Mechanism.....	4
A-Mechanism.....	4
OPERATING HANDLES.....	4
Removable.....	4
Direct Drive.....	4
Chain Drive.....	4
HE Type.....	5
HANDLE ACCESSORIES.....	5
Spline Tubes.....	5
Shaft Extension.....	5
Mechanical Door Interlock.....	5
GROUNDING SWITCHES (Type E)	5
MECHANICAL INTERLOCK.....	5
BACKCONNECT KIT	5
ELECTRICAL CONTROL OPTIONS	5
Shunt Trip.....	5
Auxiliary Switch.....	5
Fuse Auxiliary Switch.....	5
MOTOR CONTROL.....	5
NM Motor Operator.....	5
FUSE OPTION.....	6
Fuse Base.....	6
Insulator for Fuse Base.....	6
INSTALLATION and MOUNTING	
Preparation of Switch for installation.....	6
Test Operations.....	6
Back-Connect Kit.....	6
Mounting A-Mechanism.....	7
Mounting Shunt Trip.....	7
Mounting K-Mechanism.....	7
Mounting Shaft Extension to Switch Frame.....	7
Mounting Auxiliary Switch.....	7
Mounting Grounding Switch (Type E).....	7
Mounting Grounding Switch to Fuse-Switch.....	8
Mounting the Mechanical Interlock.....	8
Testing the Mechanical Interlock.....	8
Mounting Fuse-Base.....	8
Mounting of Fuse Tripping Device.....	8

Adjustment of Fuse Tripping Device.....	8
Fuse Tripping Control.....	8
Mounting the Motor Operator.....	9
Mounting Operating Mechanism Type HE.....	9
Removable Handle.....	9
Chain Drive.....	9

SERVICE AND MAINTENANCE..... 9

REPLACEMENT OF PARTS 10-11

APPENDIX

VersaRupter Load Break Switch Rating.....	12
5kV VersaRupter Outline Drawing.....	13
15kV 61kA VersaRupter Outline Drawing.....	14
5kV Back Connect Kit Outline Drawing.....	15
15kV 61kA Back Connect Kit Outline Drawing.....	16
Auxiliary Switch Kit.....	17
Shaft Extension Kit.....	18
Direct Drive Handle Kit.....	19
15kV Fuse Frame Assembly Kit.....	20
Mechanical Fuse Door Interlock.....	21
Chain Drive Handle Kit.....	22

INTRODUCTION

Application

This instruction bulletin describes the operating features, function, installation, mounting options, repair, replacement of parts and maintenance of the VersaRupter switch family. Personnel should be familiar with this instruction bulletin before installing or operating the switch.

This instruction bulletin applies to VersaRupter switches operated under the conditions listed in ANSI C37.20.2-1993 and C37.20.3-1996. Abnormal service conditions may require a de-rating of the VersaRupter switch or a modification to its application. For issues not discussed in this instruction bulletin, contact the factory as indicated on the back cover.

Receiving, Handling, & Storage

Perform an inspection of the shipping container and the VersaRupter upon receipt. Shipping damage must be reported to the shipper that delivered the switches in eight days or less to qualify for repairs and adjustments due to rough handling. The ABB warranty specifically excludes shipping damage from warranty coverage.

Determine that all items on the purchase order have been delivered. VersaRupters and its various options are shipped in separate containers. These assemblies must be installed on the switch, as required, to complete the switch package. Contact ABB at the Post Order Service toll free number, 1*800-643-7643, if it is determined that parts are missing or other field warranty authorization is required.

VersaRupters with K-type mechanisms are shipped in the closed position. VersaRupters with stored energy A-type mechanisms are shipped with the drawbars disconnected from the mechanism driven operating shaft to prevent accidental opening during shipping and handling. See the paragraph entitled, "Preparation of VersaRupters with A-Mechanisms", for special handling instructions.

Never lift the VersaRupter by the switch blades, operating shaft, or insulators; damage and misalignment will occur when lifted by these parts. Remove all packing materials then use a carry strap secured around the upper cross bar of the switch frame to lift the switch from its corrugated container. Avoid lifting chains, as they will damage the paint finish on the switch frame. Store switch in its shipping container until installation. It is acceptable to stack switch shipping containers no more than three high.

OPERATING FEATURES AND FUNCTION

Operating Mechanisms

K-Mechanisms (Snap Action)



The K-Mechanism is a single spring snap action device. The switch opens or doses by charging the spring past dead center using one of the manual operating handles. The K-Mechanism May be used with Type A1, Type A2 or Type NM motor operators for automatic opening or dosing.

A-Mechanisms (Stored Energy)



The A-Mechanism is a dual spring stored energy device that is well suited for remote tripping applications. When shunt tripping or mechanical fuse tripping is specified, the type A-mechanism must be used. The opening spring must be pre-charged before the A-mechanism can be tripped remotely. To charge the springs, the A-Mechanism shaft is rotated clockwise until hearing an audible click. To dose the A-Mechanism rotate the shaft counter-clockwise 130 degrees. Once the opening spring is charged the mechanism can be opened by a 20 degree clockwise turn. In normal operation, the opening spring is charged and latched by an operating handle or by a motor operator. The VersaRupter is then opened by any of several methods:

- Movement of the operating handle
- Motor operator
- Electrical signal to a shunt trip device
- Mechanical fuse tripping linkage

Operating Handles

Direct Drive Operating Handle



A Direct Drive Operation Handle is available for mounting directly to the right or left side of the endosure. The handle is connected directly to the mechanism operating shaft or with a spline tube extension. A left hand shaft extension is required for left hand mounting. Key interlocking or padlocking is available with the fixed-mounted handle.

Chain Drive Handle



Mounted on the front of the switch enclosure on either the right or left side, the chain drive handle provides flexibility in handle mounting angle for various enclosure designs and switch positions. The handle case contains a sprocket that is connected by a chain to a sprocket mounted on the VersaRupter mechanism shaft. The handle casting has provisions for mounting two separate key interlocks to lock the handle and switch in either the closed or open position. The chain drive handle cannot be used with a

VersaRupter motor operator. When mounting the chain drive handle on the left hand side of the enclosure, the VersaRupter must be equipped with a left hand shaft extension to provide a mounting point for the mechanism sprocket.

HE Operator (Direct Drive)

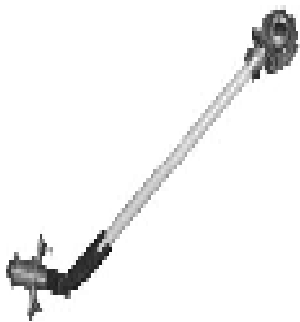

The HE Operator allows a direct shaft connection to the VersaRupter. Two assemblies are provided; a splined-shaft universal joint assembly and a bevel gear arrangement for the VersaRupter mechanism shaft. These components accept a 0.75-inch galvanized pipe (not provided) which allows the VersaRupter to be positioned up

to five feet from the front of the enclosure. When greater distances are required, 0.75 to 1-inch adapters are available. See appendix for guidance on HE operator shaft fabrication. Note that the angle between the splined shaft and the shaft to the bevel gear assembly cannot be greater than 40 degrees. HE operators are available in locking (coupled) types for manually operated forms; non-locking (de-coupled) forms must be used with motor operators. Both types incorporate open-closed indicators. Key-type interlock provisions are not available for this handle operator.

Removable (Manual) Handle



A removable handle must be specified when using the shaft drive handle operator above. This handle slides onto the splined shaft of the HE operator. When positioned on the shaft with the handle grip vertical, a 90° counter-clockwise rotation of the handle will close the VersaRupter.

Other Handle Accessories

Spline Tubes

Optional spline tubes provide the ability to create shaft extensions, customize operator handles, or link the mechanical actuation of the switch together.

Shaft Extension

Optional shaft extensions are available for left-hand operation using motor operators or manual operator handles. Some shaft extensions may be grooved for cutoff to the precise extension required.

Mechanical Door Interlock

Mechanical door locks are optionally available with the chain drive handle to lock access doors in the closed position when the load break switch is closed. Standard and offset versions of the mechanical door lock accommodate different door designs. These compliment the key interlock provisions which are standard on the chain drive handle operator.

Grounding Switches

Type E Grounding Switches



Type E grounding switches are available for grounding the hinged side of the VersaRupter in a two-step operation. The mechanical interlock is a mandatory option when specifying the Type E grounding switch.

When the VersaRupter is open, the mechanical interlock enables the ground switch to be closed using a separate manual operator. Chain drive, direct drive, or shaft drives can be used with the grounding switch.

Mechanical Interlock



The mechanical interlock prevents the VersaRupter from being closed when the Type E grounding switch is closed. Mechanical interlocks are

available in various lengths to accommodate grounding switches mounted on the hinged side of the VersaRupter as well as at the bottom of fuse base assemblies.

Back-Connect Kit

The Back-Connect Kit is a simple design of silver plated bus bar with brackets and standoff insulators. The Back-Connect Kit gives the switchgear assemblers the ability to run bus work to the back of the enclosure.

Electrical Control Options

Shunt Trip or Shunt Close



The shunt trip (or close) option is available for local push button or remote switching applications. The Shunt Trip utilizes a solenoid to actuate the A-Mechanism trip latch.

(Shunt Close is used only with the type KS-mechanism.) The shunt coils are available in a complete range of AC and DC control voltages. Using shunt coil requires an auxiliary switch to interrupt the coil circuit after the VersaRupter changes state.

Auxiliary Switch



coil is specified.

Six and eight-contact auxiliary switches are available for the VersaRupter. Shipped with and even number of normally open and normally closed contacts, the contacts are field convertible when needed. An auxiliary switch is a mandatory option when a shunt trip or dosing

Fuse Auxiliary Switch



An optional Fuse Auxiliary Switch is available to indicate an open fuse condition. This switch has two contacts, one normally open and one normally closed, and is actuated by the tie rod linkage connected to the fused base.

NM Motor Operator

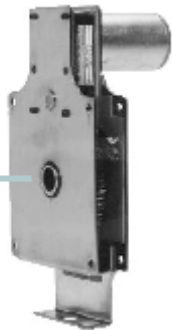

Remote electrical opening and dosing of the VersaRupter is performed by the NM motor operator. The NM motor operator is installed on the frame of the VersaRupter itself rather than remote from the switch on the front of the switch enclosure. It may be mounted on the splined shaft of the VersaRupter mechanism (either K-mechanism or A-mechanism) or on a left-hand shaft extension. Compact and light-weight, the NM motor operator allows manual operation of the VersaRupter via a direct

drive shaft operator. The NM motor operator does not have to be electrically cycled after a manual operation of the VersaRupter; it will automatically resume proper electrical operation in the proper position. The NM motor operator requires a motor contactor/relay assembly (3x3x8 inches) which may be mounted in the switch enclosure or an adjacent vertical section. See the NM Motor Operator Installation and Maintenance bulleting for complete details.

Fusing Options

Fuse Bases

Two types of fuse bases are available for the VersaRupter. The first is a fuse base that has live parts for mounting a UL Type CL-14 current limiting fuse. The second fuse base has live parts for mounting ABB Type CEF current limiting fuses. The type CEF fuse has a trigger fuse function, which can be combined with the optional mechanical fuse trip feature to open the VersaRupter when any one CEF-type fuse opens. When the CEF type fuse base is specified with the mechanical fuse trip feature, non-metallic linkages are installed over each fuse to respond to the trigger-type release on the CEF fuse. A mechanical linkage connected to the latch release of the VersaRupter A-mechanism provides switch opening to prevent single phasing of the connected load. The Type A mechanism is a mandatory option for the



VersaRupter when the mechanical fuse tripping function is specified. A bell-alarm set of contacts (1 NC – 1 NO) is optionally available for use in conjunction with the mechanical fuse tripping mechanism to monitor fuse condition.

Fuses

Type CL-14 fuses are available from ABB or other manufacturers to fit the clamp type live parts of the fuse base.

ABB manufactures type CEF and type CMF fuses specifically for use in the clip-type live parts of the VersaRupter fuse bases. Both the CEF and the CMF fuses feature the trigger release needed for the

mechanical fuse tripping feature. The type CEF fuse is a general purpose current limiting fuse. The type CMF fuse has opening characteristics suited for motor protection.

Installation and Mounting

WARNING WARNING WARNING WARNING WARNING WARNING WARNING, WARNING

The VersaRupter switch blades move rapidly with great force; always stay clear of these moving parts.

VersaRupter Preparation Prior to Installation

Inspect the VersaRupter for any obvious problems. Contact blades and the stationary main contact should be covered by contact grease. With the VersaRupter secured to a flat surface, the switch can be operated several times by sliding a removable handle onto the splined shaft of the switch mechanism. The switch will close when the mechanism operation shaft is rotated counter-clockwise (as viewed from the right-hand side) past dead center. It will open when the mechanism shaft is rotated clockwise past dead center. The stored energy action of the snap action K-mechanism guarantees the proper speed for closing and opening regardless manual actuator speed. Adjustment procedures are found elsewhere in this instruction bulletin to correct mis-alignments found during this inspection. (See special paragraph on switches with A-mechanisms.)

WARNING WARNING WARNING WARNING WARNING WARNING WARNING, WARNING

The A-mechanism is a stored energy operator that can release its stored energy with great force and speed after a very small rotation of the mechanism shaft. Stay clear of all moving parts at all times when performing installation or adjustment procedures.

Preparation of VersaRupters with A-Mechanisms

Make sure that the A-mechanism is not pre-charged prior to performing this procedure. Examine the A-mechanism photograph, making sure your mechanism appears like the one pictured below. When VersaRupters with A-type mechanisms are shipped loose,

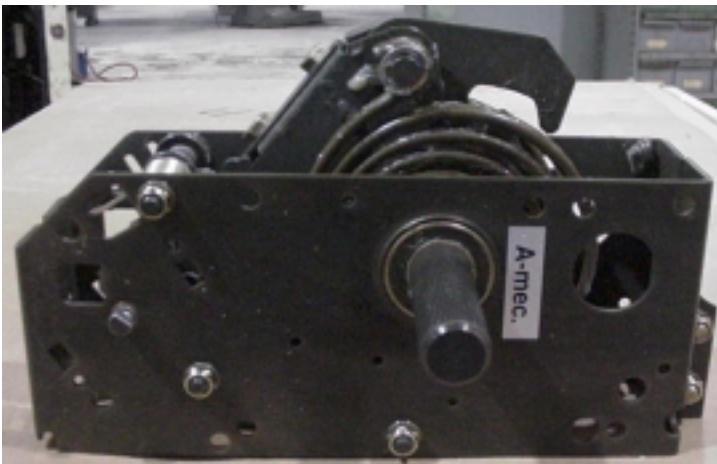

unmounted in an enclosure, the drawbars of the main contacts are disconnected from the operating shaft. After removing from the shipping container, gently pull the main contacts fully open by hand.. Connect the drawbars to the operating (jackshaft) by sliding the drawbar onto the shaft of the eccentric bolt. Install the provided washer and circlip to secure the drawbar to the eccentric bolt. The proper contact penetration adjustments were made at the factory prior to removal of the drawbar from the eccentric bolt.

Before operating the switch for the first time, the stored energy springs of the A-mechanism must be pre-charged. This should be performed after the switch has been installed in the enclosure. With the switch open, rotate the A-mechanism shaft in the clockwise direction as if attempting to open the switch. Gently move the shaft until an audible click is heard.

Operate the A-mechanism equipped VersaRupter in the same manner as one with a K-mechanism. Rotate the mechanism shaft in the counter-clockwise direction to close the switch; normal snap action closing will occur. When opening the switch, however, the first few degrees of clockwise rotation will release the stored energy of the spring and open the VersaRupter contacts. The mechanism must be fully cycled through the full stroke of the operating handle, however, to recharge the springs for the next opening cycle. (Note: After the initial spring charge, motor operators designed for VersaRupter provide the necessary movement to maintain the stored energy of the A-mechanism opening spring.)

General Mounting Guide

Locate the outline diagram in this bulletin that corresponds to the switch which will be mounted. Mounting points on the VersaRupter frame are shown on these drawings.

VersaRupter switches are normally mounted with the stationary contacts on top. Because there are no gravity dependent latches, the switch may also be inverted so that the stationary contacts are on the bottom. The switch will also perform satisfactorily when mounted on its back or suspended from the roof of an enclosure.

In general, inter-phase barriers are not required on the VersaRupter because the arcing by-products following interruption are not near the adjacent poles as they are on switches with arcing flipper blades. Although these barriers are not required for the proper operation of the switch, nevertheless, local codes and regulations may require those barriers.

Observe electrical clearances as required by applicable standards and codes.

Back-Connect Kit

1. When mounting the Back-Connect Kit, first secure the brackets to the frame with the same bolts used to secure the VersaRupter frame to its enclosure. See Figure 1. These instructions apply for top and bottom mounting of the back connect insulated bus bars.
2. Attach the standoff insulators to the brackets provided using ½ inch bolts.
3. Mount the insulated bus bars to the standoff insulators using one 3/8 inch bolt, a steel 3/8 inch washer and two red washers.
4. Install the GP03 washers such that they are positioned on each side of the back connect bus bar to protect the bus bar insulation. The steel 3/8 inch washer should be between the GP03 washer and the head of the 3/8 inch bolt.
5. The back connect bus bar is attached to the VersaRupter terminals with the hardware provided with the VersaRupter. The back connect bus bars may

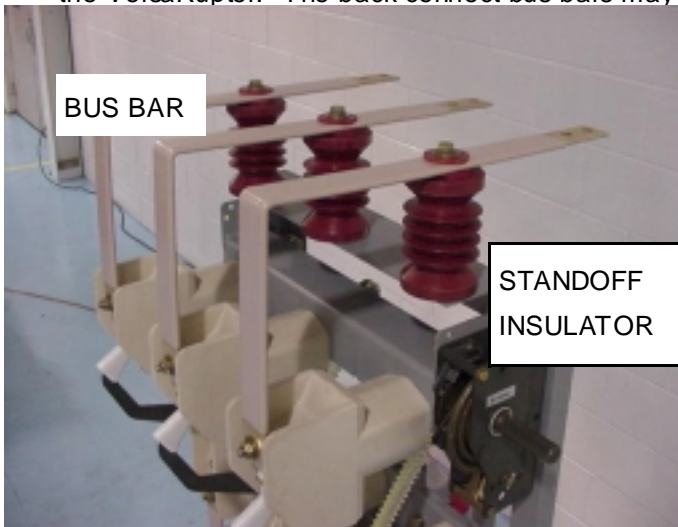

be connected to cabling or bus work as needed. For dielectric purposes, bus boots may be installed at the termination of the back connect bus bar and the field connections.

6. Torque all hardware in accordance with standard torquing guidelines per the bolt sizes.

Field Replacement Procedures

CAUTION:

All VersaRupter repair must be performed when the primary power circuit is de-energized.

Mechanism Replacement

1. The VersaRupter must be in the open position. After removing handle mechanism assemblies from the shaft of the mechanism, remove the three bolts,

lockwashers, and nuts that secure the mechanism to the switch frame.

2. Pull the mechanism straight out away from the frame to free it from the hollow main jackshaft. Re-install this hardware on the removed mechanism to secure the sides of the mechanism; the new mechanism will have its own hardware for the installation.
3. Prepare the new mechanism for installation by removing the nuts and lockwashers securing the sides of the new mechanism so that the bolts may slide into the mounting holes in the frame. (Note: The shortest bolt and nut must be totally removed and reversed so that it passes first through the mech side, then through the frame to be secured by its lock washer and nut on the inside of the frame assembly.)
4. Position the replacement mechanism so that the mechanism dutch aligns with the jackshaft assembly. It may be necessary to gently move the jackshaft assembly so that it achieves alignment with the mechanism.
5. Install three bolts and nuts. Tighten until the hardware is snug tight. Test the operation of the switch, if possible, with a removable handle. Re-install the handle operator hardware when mechanism installation is complete.

A-mechanism Notes

Because the A-mechanism is used when shunt trip or mechanical fuse trips are employed, additional components may need to be removed from the existing mechanism and transferred to the new mechanism during the installation process. Refer to the appropriate sections of this bulletin for information on removal and installation of those options.

Confirm that the mechanism latch is in the proper, unlatched position prior to performing A-mechanism installation. Installation of the A-mechanism is otherwise similar to that of the K-mechanism with regard to mechanism dutch alignment. The hardware on the A-mechanism differs from that of the K-mechanism, however. *Bolts on the A-mechanism are captive.* Simply remove the nuts and washers on the A-mechanism prior to mechanism installation; re-installing that hardware after installation. Tighten snug tight. Re-install shunt trip/mechanical fuse trip functions as applicable; do this before operational checks of the mechanism. Remember that the A-mechanism must be pre-charged prior to placing into service; make this pre-charge operation the very last step in the procedure to avoid having the springs charged during the time the latch release operators are being manipulated.

Mounting and Wiring the Shunt Trip

1. Confirm that the A-mechanism is in the unlatched state prior to performing this procedure. If not, rotate the A-mechanism splined shaft 60° counter-clockwise to release the spring then return the shaft to its neutral position.
2. Locate the mounting holes in the A-mechanism that are used for the shunt trip by positioning the shunt trip on the A-mechanism surface that is facing forward. Install a screw, lock washer, and nut loosely in this hole.
3. Pre-assemble the white disk on the half moon shaft on the right hand side of the A-mechanism. Slide the shunt trip bracket onto the screw just loosely installed. Move the shunt trip linkage up to the white disc and locate the hole in the white disk that will provide the maximum movement of the white disc when the coil is energized. Mark this hole. Remove the shunt trip assembly and the white disk from the A-mechanism.
4. Assemble the shunt trip linkage (B) to the white disk (A) through hole just marked making sure the linkage is between the white disk and the A-mechanism housing. Use the small pin and retainer provided to secure the linkage installing the retainer on the outside of the white disk rather than to the inside adjacent to the A-mechanism housing.

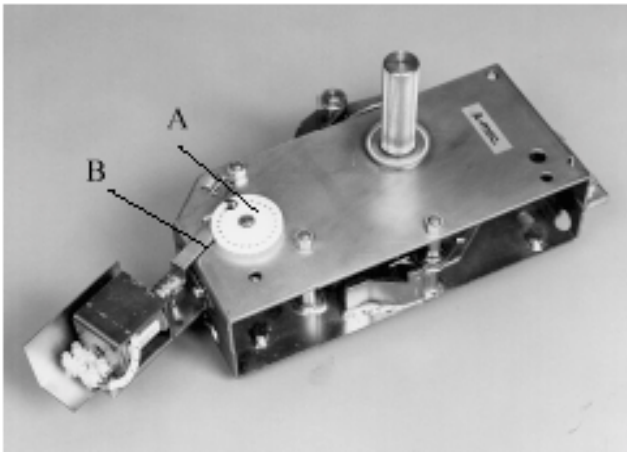

5. Permanently install the shunt trip by positioning the shunt trip assembly onto the previously installed screw. Install the other screw, lockwasher, and nut tightening all snugly.
6. Slide the white plastic disk provided onto the half-moon stud on the outside (right-hand) side of the A-mechanism. Secure the white disk with the large retainer provided.
7. The shunt trip assembly is provided with a pull-apart wiring termination. Using a small flat blade screwdriver, gently pry the white plastic housing away from the female housing to which the coil wires are

attached. This plug assembly can now be removed and wired away from the shunt trip coil itself. Re-attach by plugging this male portion back into the female portion to complete the circuit.

Note:

Shunt trip coils are intermittent duty; they must have an auxiliary contact in series with the coil that opens the shunt trip circuit when the main switch contacts part. Refer to the section labeled, "Auxiliary Switch Installation," for additional details.

Auxiliary Switch Installation

1. The auxiliary switch is delivered pre-assembled to its mounting bracket. The switch linkage is also installed onto the shaft of the switch. Refer to the diagram provided in the appendix.
2. Locate the welded auxiliary switch lever on the jackshaft. Mount the switch so that its linkage reaches and connects to this lever.
3. Place a lock washer on each bolt and screw into the pre-tapped holes in the switch frame. Tighten snug tight. (Because pre-tapped holes are now provided, the nut and lock washer shown in the diagram is no longer required.)
4. Connect the switch linkage to the jackshaft lever and secure with a washer and retainer.

The auxiliary switch is assembled so that the internal contacts are positioned "a b a b a b" (NO, NC, NO, NC, NO, NC) when viewed from the input shaft end of the switch. Contacts in this switch are field convertible.

An "a" (normally open) contact must be in series with the shunt trip coil to prevent shunt trip coil damage due to continuous energization.

Left-Hand Shaft Extension Installation

The mechanism of a VersaRupter is always mounted on its right hand side. Some applications of the VersaRupter require left-hand operation. Those include mechanical interlock operation for grounding switch application, some motor operator applications, and some manual handle operator applications. To operate the switch from its left hand side, a left hand shaft extension must be installed. These vary in length according to VersaRupter pole spacings but general installation is always the same.

1. Prepare the shaft installation for installation by installing the ring type retainer onto the shaft extension according to the drawing found in the appendix. Loosely thread the white plastic retainer onto the shaft and have the mounting hardware at hand.
2. The left hand shaft extension is installed through the hollow jackshaft so that it engages the mechanism

- from the left side.
- Slide the shaft extension through this shaft until it contacts the mechanism. Rotate the shaft, pushing in slightly until the key way drops into the machined slot of the mechanism.
 - Hold this steady then secure the plastic retainer to the switch using the nuts and lock washers provided in the kit. Tighten these snugly but not so tight as to crack the plastic retainer.

Type E Grounding Switch Preparation Prior to Installation

The grounding switch allows the lower terminals of the VersaRupter (or the lower terminals of the fuse base) to be grounded. The grounding switch must be mechanically interlocked with the VersaRupter so that it cannot be closed when the VersaRupter is closed. Separate operating handles must be provided for the VersaRupter and grounding switch; selecting chain-drive handles provide key interlocking provisions for additional operator safety.

Grounding switches are specified in accordance with the pole spacing of the VersaRupter to which they are attached. Left and right hand splined shafts are provided on the grounding switch. The VersaRupter must have a left hand shaft extension installed. Typical installations position the direct, shaft, or chain-drive handles on the right with the mechanical interlock installed on the left-hand shafts.

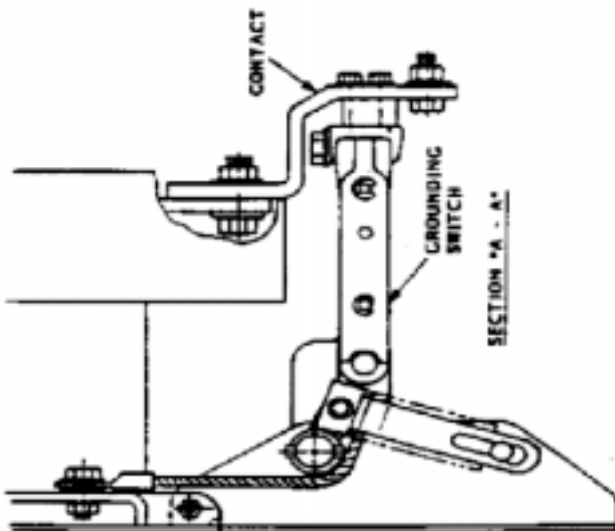

- Locate the three bus pieces on which the stationary contacts of the grounding switch are installed. Each of these pieces has a clearance hole for the Allen-head screw and a bolt hole that aligns with the bolt hole of the lower terminal. (Note: The 1200 ampere switches have a clearance hole and two bolt holes.)

- Attach these stationary grounding contact supports to the lower terminal using the lower terminal hardware provided with the VersaRupter but do not fully tighten the nuts and bolts.
- Visually align the contacts. Lubricate these stationary contacts with the lubricant provided in the kit.
- Secure the Type E grounding switch frame to the VersaRupter frame using the hardware included.

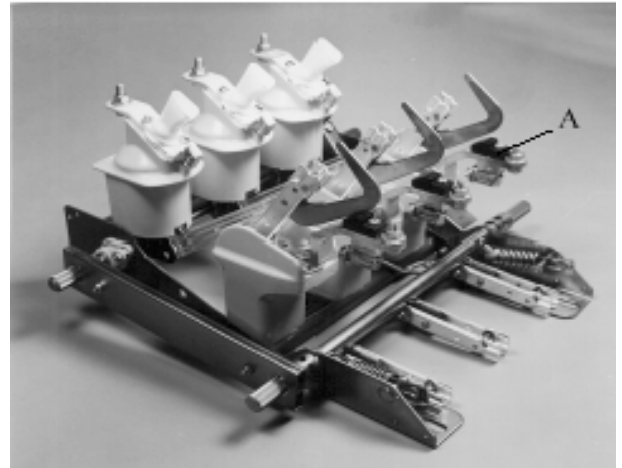

- Tighten all bolts securely.
- Using a removable handle, close the grounding switch onto the previously mounted stationary contacts. This action will align the stationary contacts.
- Tighten the nuts and bolts that hold the stationary contacts to the VersaRupter lower terminal. Open the grounding switch to prepare for mechanical interlock installation.

Grounding Switch Mechanical Interlock Installation

The mechanical interlock spans the distance between the VersaRupter left-hand shaft extension and the left shaft of the ground switch. (Mechanical interlocks are also available for applications where the grounding switch is mounted to the bottom of a fuse base which is, in turn, mounted to the bottom of the VersaRupter.) Confirm that the VersaRupter is open. (On VersaRupter with A-mechanism, the A-mechanism opening springs must be pre-charged prior to mechanical interlock installation.)

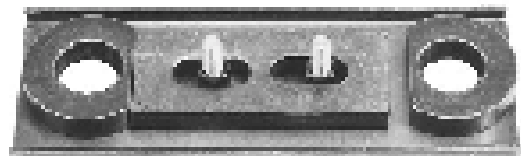

- Disassemble the mechanical interlock by removing the two bolts and nuts.

2. Place interlock guide plate over the left-hand shaft extension of the VersaRupter and the left shaft of the grounding switch.
3. Install the bolts from the back of the guide plate and install the guide bushings on the bolts.
4. Slide the interlock slider onto the guide bushings and bolts.
5. Slide one interlock ring onto the splined left-hand shaft extension with the flat portion nearest the interlock slider.
6. Slide the other interlock ring onto the splined left shaft of the grounding switch again with the flat portion nearest the interlock slider. Install the remaining guide plate over the splined shafts and the bolts and tighten the nuts to secure the two halves of the interlock assembly.

The fully assembled VersaRupter/grounding switch combination may now be installed into the switch enclosure. Positively ground the grounding switch braided ground connection to the enclosure grounding system.

Fuse Base Mounting

The CL-14 type fuse base features a welded frame on which the insulators and live parts are mounted. The fuse base is connected to the VersaRupter by bus bar specifically formed for the purpose. The fuse base frame is first secured to supports in the switch enclosure before the bus connectors are installed. CEF/CMF Fuse bases are offered for mounting on either the top (line side) or the bottom (load side) of the VersaRupter. The terminals of the switch provide the mounting points for the fuse clips and the optional fuse trip accessories. The frame for the three standoff insulators and remaining fuse clips is mounted the proper distance (based on fuse length) from the fuse clips mounted on the VersaRupter terminals.

Mechanical Fuse Trip Mechanism Installation

Non-metallic components are mounted directly onto the current-carrying parts of the VersaRupter that support the trigger end of the CEF (or CMF) fuse.

1. On each pole, attach the plastic lower bearing block to the fuse base bus bar screwing the machined screw into the pre-tapped hole provided.
2. Install the lever/fuse trip flag into the lower bearing block of each pole. Orient the fuse trip flag so that the flag portion of the lever is adjacent to the fuse clip on the fuse base bus bar.
3. Locate the release shaft of the A-mechanism on the right hand side of the VersaRupter. The release shaft extends through a clearance hole in the VersaRupter welded frame. Locate a similar clearance hole on the switch frame on the left hand side of the switch. Install the trip bar plastic bearing in the

left hand frame hole.

4. Install the white plastic drive ring onto the release shaft of the A-mechanism.
5. Note that the tripper bar has a plastic operator with pins that engage holes in the plastic drive ring. Install a washer on the tripper bar then slide the tripper bar through the bearing on the left side and engage the drive ring on the right side.
6. Secure the tripper shaft temporarily with a the cotter pin provided but do not spread the ends of the cotter pin.
7. The release rods are mounted onto the hooks on the release shaft and secured to the trip flag levers using hardware provided. Note this assembly is not in adjustment; proceed to the next procedure.

Mechanical Fuse Tripping Adjustment

Prior to making this adjustment, the opening spring of the A-mechanism must be charged.

1. Remove the cotter pin installed in the procedure above. Pull the tripper shaft away from the drive disc on the A-mechanism trip shaft.
2. Turn the tripper shaft so that each of the three hooks on the tripper shaft are taught allowing a gap of 3 to 6 millimeters between the strike pin of the fuse trigger to the tripper flag.
3. When making these adjustments, position each fuse in the fuse clips so that it is resting on the top of the fuse clip of the fuse base. In this position, the distance between the strike pin and the tripper flag must not exceed 12 millimeters.
4. Test the adjustment by dosing the VersaRupter. Staying clear of the switch blades, move any one of the trip flags 1-2 centimeters to confirm that the VersaRupter opens.
5. If the VersaRupter does not open, the tripper bar adjustments must be re-checked and readjusted.

Note: These adjustments may also be made with a test fuse installed in the fuse clips. The test fuse must comply with DIN 43625.

Mounting the Motor Operator

Refer to the manual provided with the motor operator for mounting and installation instructions.

Mounting Operating Mechanisms Type HE

The Type HE Hand Operator Mechanism includes bevel gears and a front mount universal joint. Standard HE operators have a locking ring that must be pulled out as the (removable) handle is rotated to open or close the switch. HE operators used with motor operators do not have the locking ring.

1. To achieve the proper rotation of the mechanism shaft, the bevel gear must be oriented properly. To allow easy access to the set screws of the bevel gear assembly, the bevel gear assembly should be installed before the VersaRupter is installed in its enclosure. Rotate the bevel gear assembly so that the two set screws are visible through the access holes in the bevel pivot casting.
2. For installation on the right side of the switch on the mechanism shaft, slide the HE bevel gear assembly onto the splined shaft so that the gear teeth face into the mechanism. If mounting on a left-hand shaft extension, the gear teeth face away from the VersaRupter. Tighten the two set screws when the bevel gear assembly is positioned on the shaft so that it will align with the front mounted Handle operator.
3. Fabricate the shaft which spans the distance from the bevel gear assembly to the front panel mounted HE operator. Measure the distance from the center point of the VersaRupter operating shaft to the pivot point of the universal joint at the rear of the HE operator. For the shaft length between the two, subtract 137 millimeters from the distance measured above. (Note: When the distance between the universal joint and the bevel gear is more than 2000 MM (6 ft.) use a 1" diameter galvanized pipe and 3/4 to 1 inch couplers. Bore a through holes 10 mm in diameter at 33 mm from one end and 13 from the other end to complete the shaft.
4. Install the shaft in the bevel gear and universal joint using the pins with cotter pins provided.
5. Using a retainer ring tool, remove the arrester ring retainer on the front of the HE operator then remove the arrester ring.
6. Place the removable handle on the splined shaft with the hand vertical, then pull downward in a counter-clockwise direction to open switch.
7. Re-install the arrester ring loosely, so the ring properly indicates that the switch is open. Install the removable handle and close the switch checking the indication of the arrester ring. Seat the arrester ring then install the retainer ring.

SERVICE AND MAINTENANCE

Cleaning

After maintenance the switch disconnecter must be cleaned before being put into service. Strong solvent and alcohol must not be used. After cleaning, the contacts area of the main blades and the fixed contacts must be greased with ISOFLEX TOPAS NCA52. If the switch disconnecter is placed in a very humid and/or polluted caustic environment this will reduce the tracking resistance.

Switch Disconnecter in Service

The switch disconnecter should be checked at least once a year by operating the switch several times to check all the functions. The frequency of maintenance will depend on the time in service and environmental conditions.

- Moving and fixed contacts are greased with Isoflex Topac NCA 52.
- Mechanisms do not need any greasing under normal conditions
- Arcing knives, pistons and cylinders must not be greased

Mechanical Overhaul

After 1000 operations or 5 years in service a complete overhaul of the switch disconnecter should be performed (preferably by ABB-personnel).

Electrical Overhaul

The frequency of overhaul depends on the number of operations and the magnitude of the breaking current. After approximately 100 operations at rated current or approximately 500 operations at half the rated current the main contacts, arcing contacts and arc extinguishing chamber must be inspected and possibly replaced. Replacement is recommended when:

- The tip of the arcing contact knives has diminished approximately 3mm.
- The fixed arcing fingers are burned or do not make contact
- The width of the slot in the arcing chamber is more than 8mm

Inspection of VersaRupter Knives After Mounting

Due to difference in wall and support frame straightness it is necessary to check the position of the main knives on the fixed contact. **(Draw arms are detached on switches with A-Mechanism)**

1. With the draw arms detached hold the main contact by hand. Operate the switch several times. Check that the arcing knife moves freely in the arc chamber
2. Pull the main contact to the open position. Attach the draw bar to the main shaft by the eccentric bolt and secure it with the washer and circlip

Switch with K-Mechanism

1. Close the switch by operating the mechanism. Check the engagement and the contact overlap. All four contact points on the main contacts must be in touch with the fixed contacts.
2. The eccentric bolt (see immediately below) adjusts the depth between the fixed and the moving contacts if the moving contact is outside the limit of 4mm (see below).

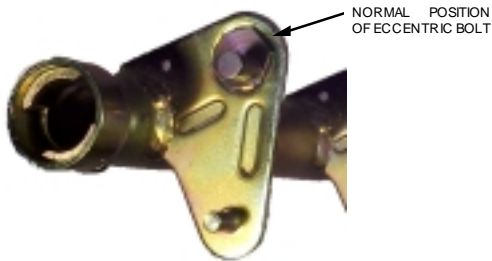

Note: For all switches including 61kA switch the minimum and maximum depths are shown below:

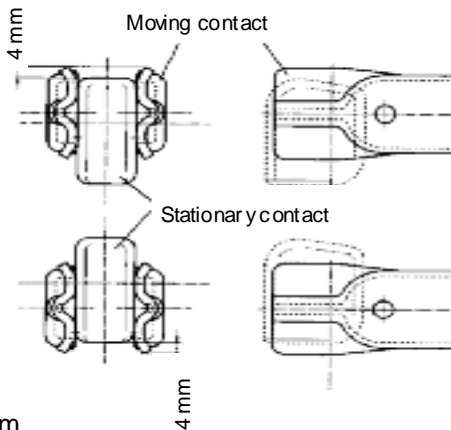

Minimum depth
(The moving contact will sit a maximum of 7mm above the fixed contact)



contact
moving contact maximum above the contact

Maximum Contact Depth



PART REPLACEMENT

The VersaRupter is equipped with glassfiber-reinforced polyester insulators with self-tapping screws (or lag studs) for securing insulators and contacts. If the same insulator and screws are to be used after exchange of parts the following procedure must be followed:

1. Unscrew the selftapping screws carefully and brush them clean. Blow out any particles in the thread hole (protect your eyes). When mounting the screws must be entered carefully onto the threads in the insulator and tighten with care.
2. Torque to 15Nm (11.1ft-lb)

If a new insulator is to be mounted, the hole in the insulator must be threaded approximately 10mm deep by the selftapping screw before mounting. Remove the screw and blow the hole clean.

Lower Insulator Replacement

Set the switch disconnecter in the open position with both the operating springs uncharged.

- a) Remove the circlips and washers attaching the draw bar to the main shaft. (Eccentric bolt does not need to be loosened)
- b) Remove the screw(s) attaching the main contact to the insulator. Remove the fixed contact with the contact knife and draw bar
- c) Attach the new main contact along with the contact knife and draw bar to the insulator.
- d) Grease the new contact knife with ISOFLEX TOPAC NCA 52 and check carefully to see that it enters the fixed main contact correctly. Check that the arcing knife moves freely in the arcing chamber

when closing and opening **Note:**The arcing knife does not have the same position related to the contact knife during the dosing and opening movement. The contact knives must rotate firmly at the pivot point without jerking.

- e) Attach the draw bar to the main shaft by the eccentric bolt and secure with the washer and circlips.
- f) The depth of engagement between fixed and main contact can be adjusted with the eccentric bolt or by moving the lower insulator back or forth.

Replacement of Fixed Contact on the Opening Side (refer to figure below)

- a) With the switch in the open position, unscrew the two mounting screws (3.1) and lift up the arcing chamber and the thermal disc (3.4) while pressing the main contacts (3.6) firmly against the hollow insulator.
- b) Lift up the main contact (3.5) by the arcing contacts, which penetrate the main contact. Remove the pressure spring (3.7) and clean the top of the insulator and hole, and blow out the threaded hole. (Protect the eyes)
- c) Attach the new main contact in reverse order as described above. Damaged parts must be replaced. Make sure that the arcing contacts are correctly placed in the pressure spring.
- d) By mounting the thermal disc and the arcing chamber, the main contact must press firmly against the hollow insulator. Attach the whole assembly by the mounting screws. Check for the correct position of the arcing contact. Grease the contact area with ISOFLEX TOPAC NCA 52.

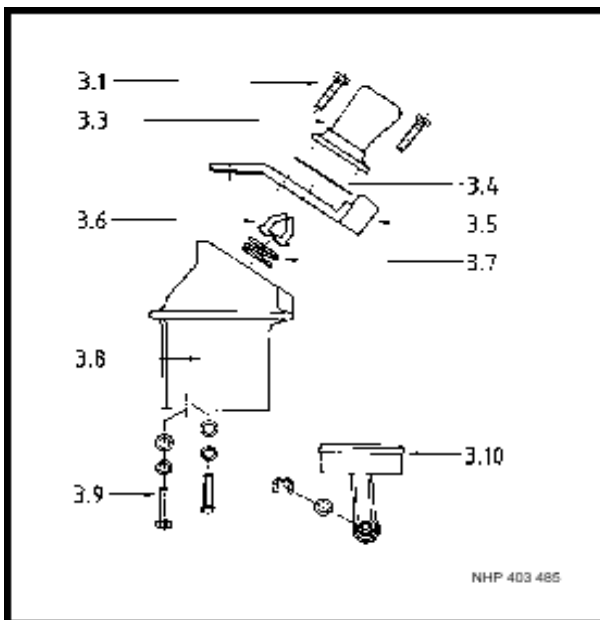

Replacement of Upper Insulators (refer to previous figure)

The insulator with arcing chamber comes pre-assembled.

- a) Unscrew and detach the insulator.
 - b) Attach the new insulator to the frame by the two selftapping screws. Remember to mount the piston with piston rod.
- Grease the contact area with Isoflex Topac NCA 52.c)
Attach the new insulator to the frame by using the two selftapping screws.
- d) Attach the fuse dips and contact block to the top of the insulator using the screws.

Replacement of Fixed Contacts on the Pivot Side

Normally the main contact with contact knife and draw bar is delivered as one unit.

Pivot Side Support Insulator

Detach the main contact with contact knives as describe above.

- a) Unscrew and detach the insulator
- b) Attach the new insulator to the frame by the two selftapping screws
- c) Attach the main contact with the contact knife to the top of the insulator and adjust.

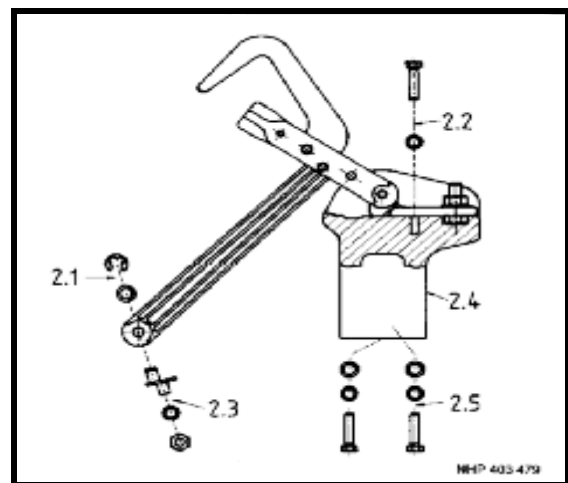

Appendix

System Rating KV Nom.	Rated Max. Voltage kV	Voltage Rated Dielectric BIL Imp. kV	Low Frequency Withstand kW	Rated Cont. Current Amps	Load Interrupt Capacity Amps	Current Rated Mom. Current Asym. RMS kA	Fault Close Current Asym. RMS kA	Snap Action Catalog Number	Stored Energy Catalog Number
4.73 kV (Pole Spacing: 5.9 inches)	8.25	75	26	200	200	40	40	244-040-502	245-864-501
				600	600			244-040-506	245-864-502
				1200	1200			244-040-510	245-864-503
12.00 thru 13.80 (Pole Spacing: 6.69 inches)	15	95	36	200	200	40, 61	40, 61	244-041-502	245-864-504
				600	600			244-041-506	245-864-505
				1200	1200			244-041-510	245-864-506
12.00 thru 16.80 (Pole Spacing: 9.25 inches)	15.5	110	50	200	200	61	61	245-881-518	245-864-529
				600	600			245-881-521	245-864-530
				1200	1200			245-881-524	245-864-531
12.00 thru 16.80 (Pole Spacing: 9.25 inches)	17	110	50	200	200	40	40	244-042-502	245-864-507
				600	600			244-042-506	245-864-508
				1200	1200			244-042-510	245-864-511
22.9 thru 24.9 (Pole Spacing: 10.8 inches)	27	125	60	200	200	40	40	244-043-502	245-864-513
				600	600			244-043-506	245-864-514
				1200	1200			244-043-510	245-864-517
34.5 (Pole Spacing: 14.1 inches)	38	150	80	600	600	40	30	244-005-501	245-864-519
				800	800			244-005-502	245-864-520

Table 1: VersaRupter Load Break Switch Rating

CATALOG # (REF.)	AMP	MAX. V. (KV)	UNVT	A	A2	A3	E	H	H1	H2	K	K1	M	N	N1	N2	P	R	S	T	T1	T2	U	V	V1	Z
244-141-310	200	61	5/0.25	1.62	1.54	1.52	1.53	1.54	1.55	1.56	1.57	1.58	1.59	1.60	1.61	1.62	1.63	1.64	1.65	1.66	1.67	1.68	1.69	1.70	1.71	1.72
244-140-303	300	61	5/0.25	1.66	1.58	1.56	1.57	1.58	1.59	1.60	1.61	1.62	1.63	1.64	1.65	1.66	1.67	1.68	1.69	1.70	1.71	1.72	1.73	1.74	1.75	1.76
244-140-305	500	61	5/0.25	1.67	1.59	1.57	1.58	1.59	1.60	1.61	1.62	1.63	1.64	1.65	1.66	1.67	1.68	1.69	1.70	1.71	1.72	1.73	1.74	1.75	1.76	1.77
244-140-306	500	61	5/0.25	1.67	1.59	1.57	1.58	1.59	1.60	1.61	1.62	1.63	1.64	1.65	1.66	1.67	1.68	1.69	1.70	1.71	1.72	1.73	1.74	1.75	1.76	1.77
244-140-307	500	61	5/0.25	1.67	1.59	1.57	1.58	1.59	1.60	1.61	1.62	1.63	1.64	1.65	1.66	1.67	1.68	1.69	1.70	1.71	1.72	1.73	1.74	1.75	1.76	1.77
244-140-307	250	60	5/0.25	1.66	1.58	1.56	1.57	1.58	1.59	1.60	1.61	1.62	1.63	1.64	1.65	1.66	1.67	1.68	1.69	1.70	1.71	1.72	1.73	1.74	1.75	1.76

Notes: This layout drawing includes optional K-Mechanism and Left Extension. The stored energy mechanism (A-Mechanism) has a standard shaft length of 3.5 inches.

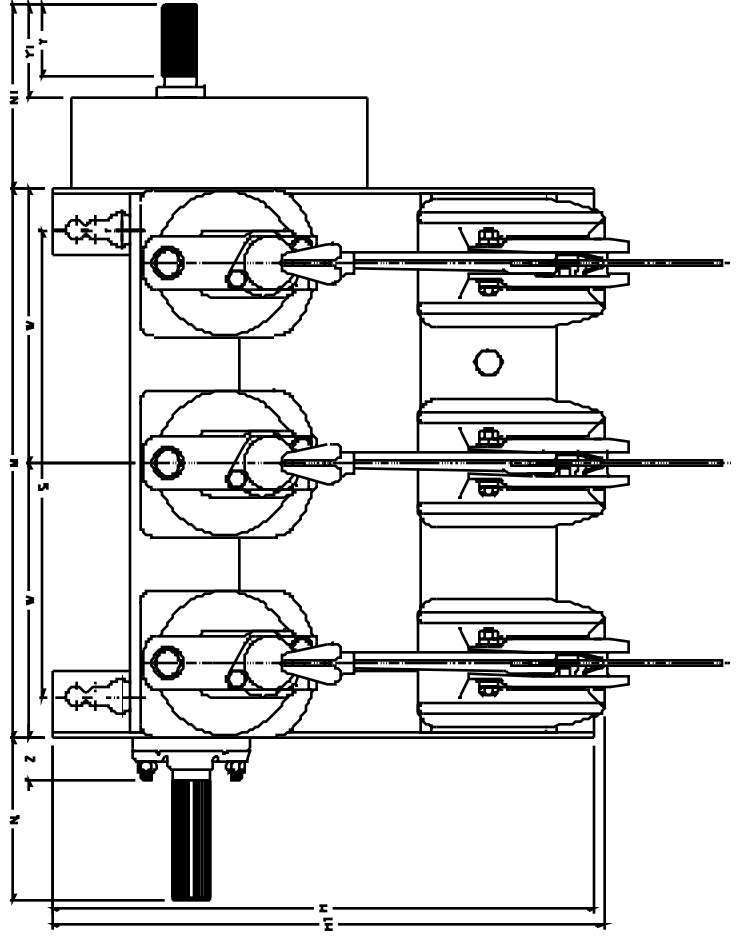
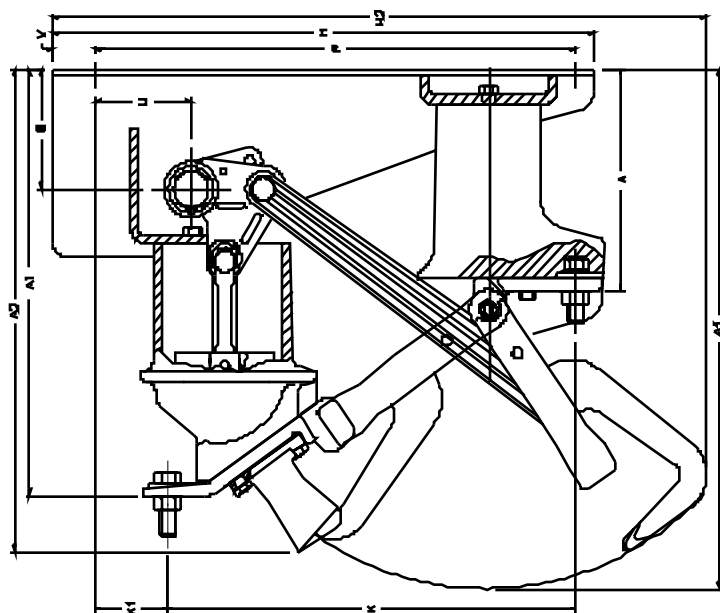

5KV VersaRupter

5KV VersaRupter
 5 for 12/18/2013
 5-20183
 EPL 244-040
 1-1-2013

REV	DATE	BY	CHK	DESCRIPTION
1	1/1/2013			ISSUE FOR PRODUCTION
2	1/1/2013			ISSUE FOR PRODUCTION
3	1/1/2013			ISSUE FOR PRODUCTION
4	1/1/2013			ISSUE FOR PRODUCTION
5	1/1/2013			ISSUE FOR PRODUCTION

5KV VersaRupter
 5 for 12/18/2013
 5-20183
 EPL 244-040
 1-1-2013

REV	DATE	BY	CHK	DESCRIPTION
1	1/1/2013			ISSUE FOR PRODUCTION
2	1/1/2013			ISSUE FOR PRODUCTION
3	1/1/2013			ISSUE FOR PRODUCTION
4	1/1/2013			ISSUE FOR PRODUCTION
5	1/1/2013			ISSUE FOR PRODUCTION

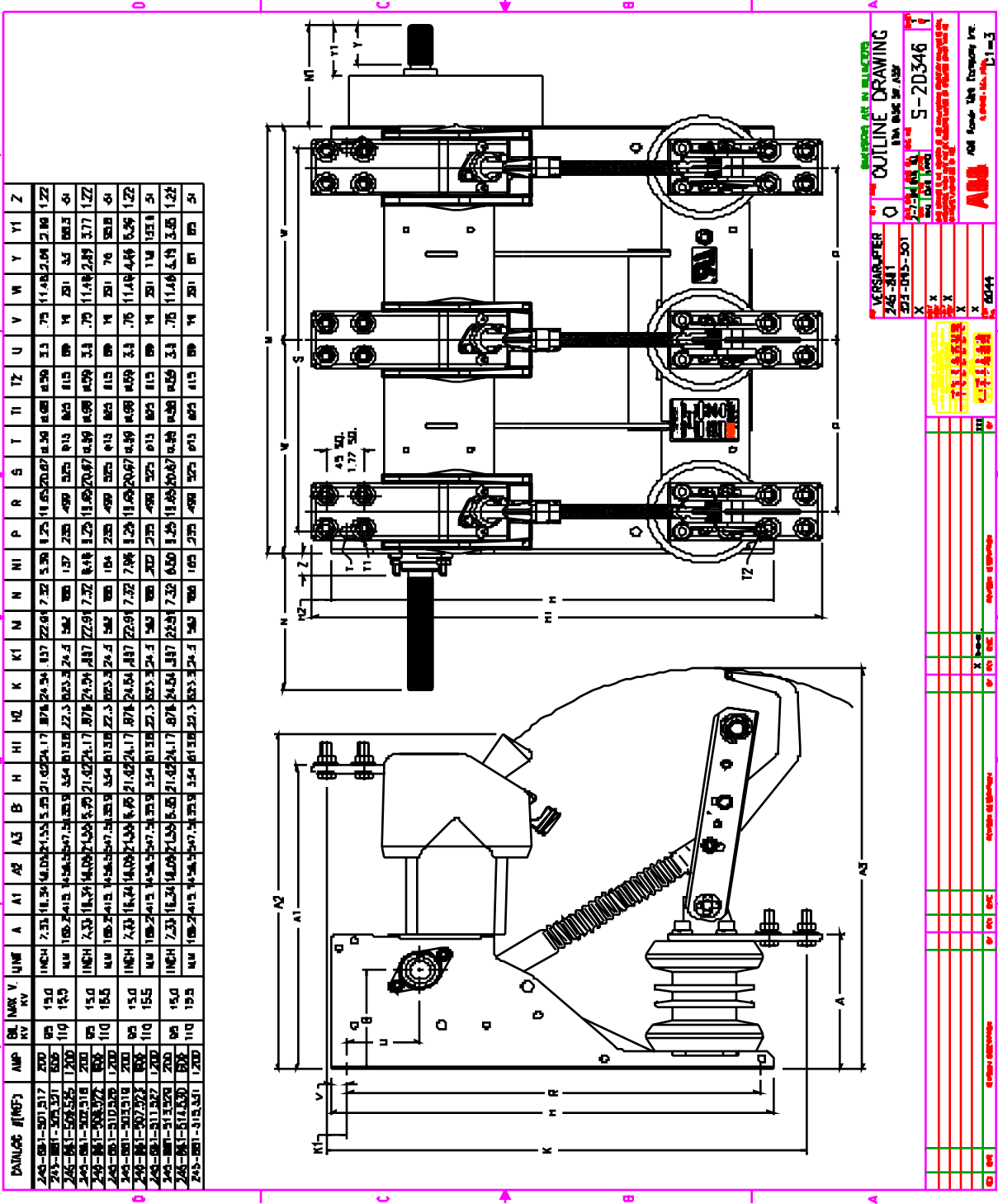

15 Kv, 61 KA Fault Close

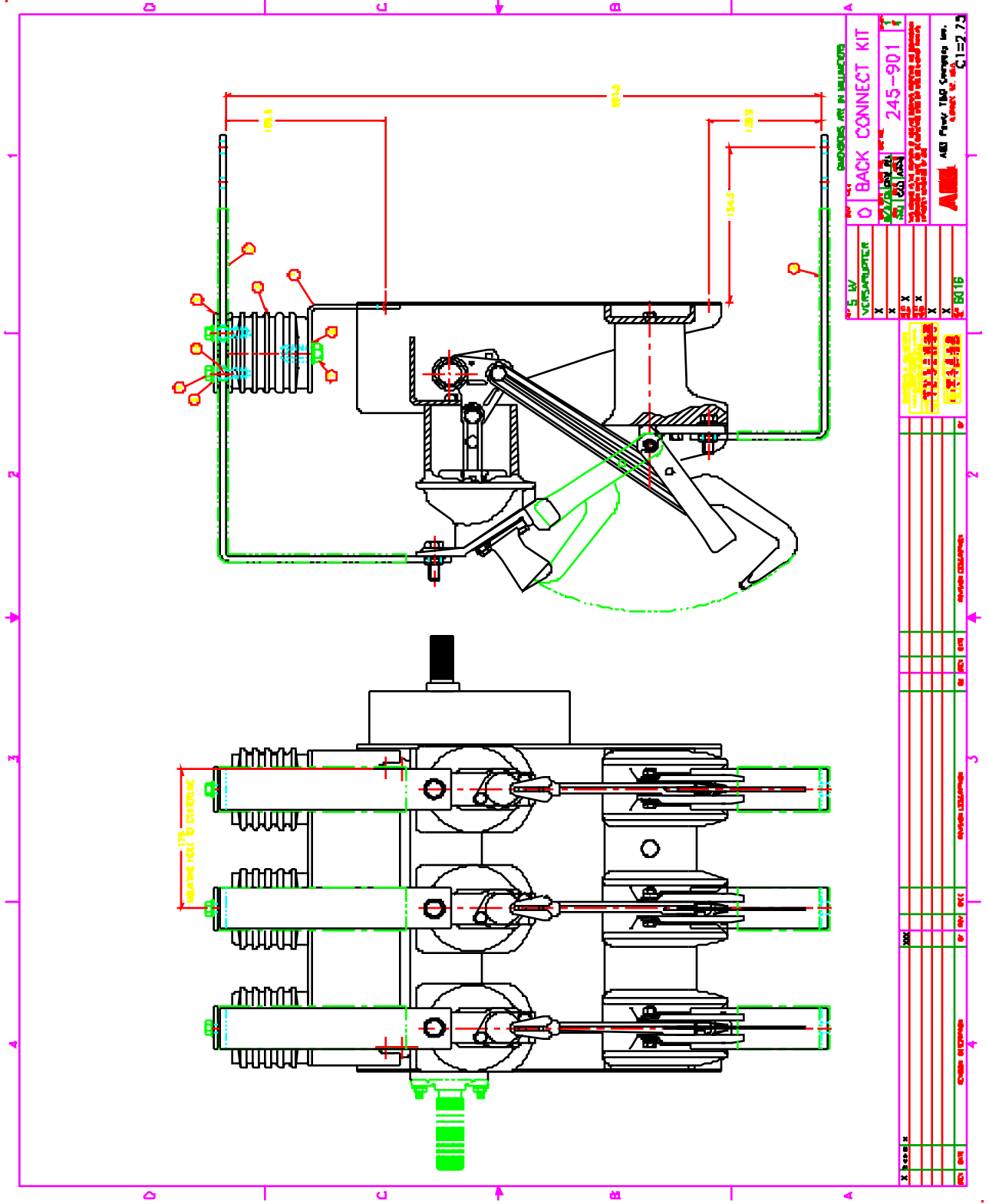

Versa - Rupter Auxiliary Switch Kit Six Circuits

F1 - 091 Rev. 1 Page 1

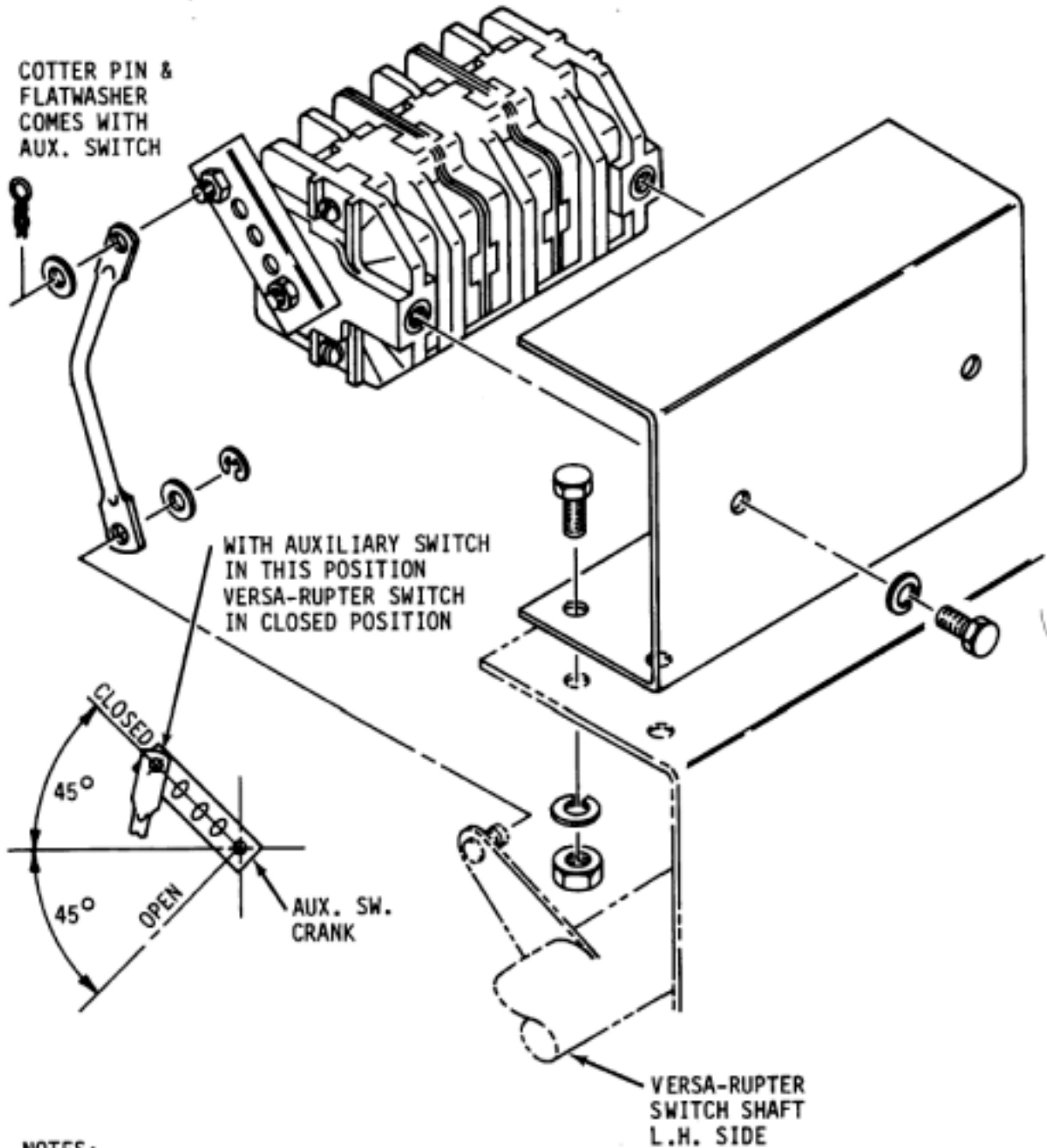

NOTES:

1. SIX (6) CONTACT SWITCH SHOWN.

Versa-Rupter Shaft Extension Kit, Left Side Handle Mounting

FI-090 Rev. 0 Sht. 1

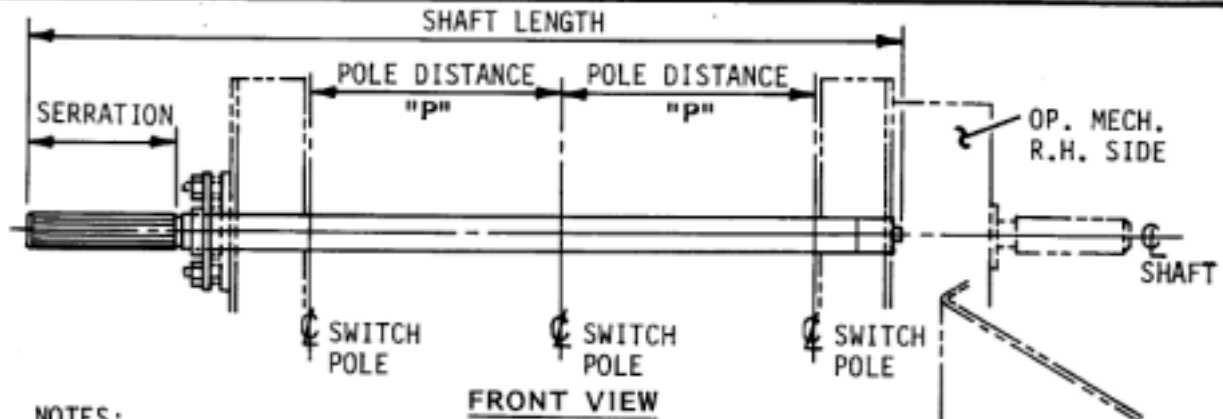

NOTES:

1. TO INSTALL SHAFT, INSERT & ROTATE SHAFT UNTIL SLOT ENGAGES MECHANISM. TAP IN PLACE UNTIL GROOVE FOR TRU-ARC RING IS CLOSE TO NYLON BEARING. TRU-ARC RING MUST BE FREE TO ROTATE BETWEEN NYLON BEARINGS.
2. ITEMS A, B, C, D, E ARE PACKAGED WITH EACH SHAFT EXTENSION.

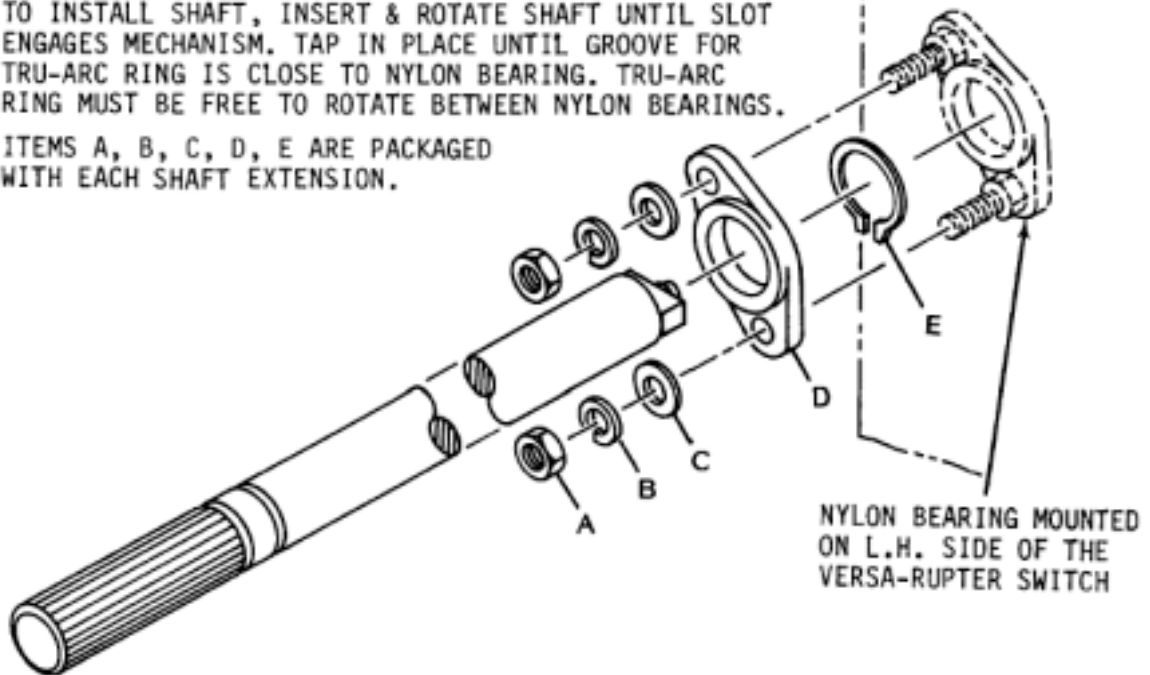

DESCRIPTION	"P"		SERRATION		SHAFT LENGTH	
	MM	INCH	MM	INCH	MM	INCH
L.H. SHAFT EXTENSION (8.25 KV)	150	5.91	78	3.07	518	20.40
" " " (15.0 KV)	170	6.69	"	"	558	21.97
" " " (17.0 KV)	235	9.25	"	"	756	29.77
" " " (27.0 KV)	275	10.83	"	"	836	32.91
" " " (38.0 KV)	360	14.18	129	5.08	1172	46.14

FI-090 Rev. 0
Sht. 1

Versa-Rupter, Side Mounted, Direct Drive Handle Kit, Right Side Mounting

FI-089 Rev. 0 Page 1

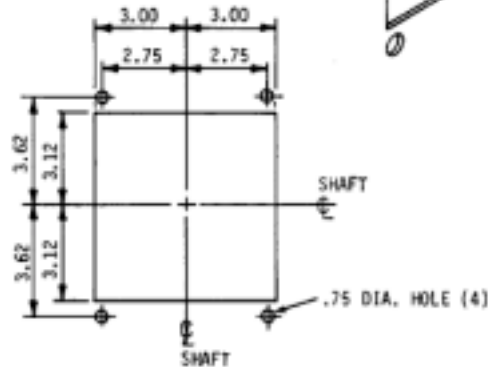
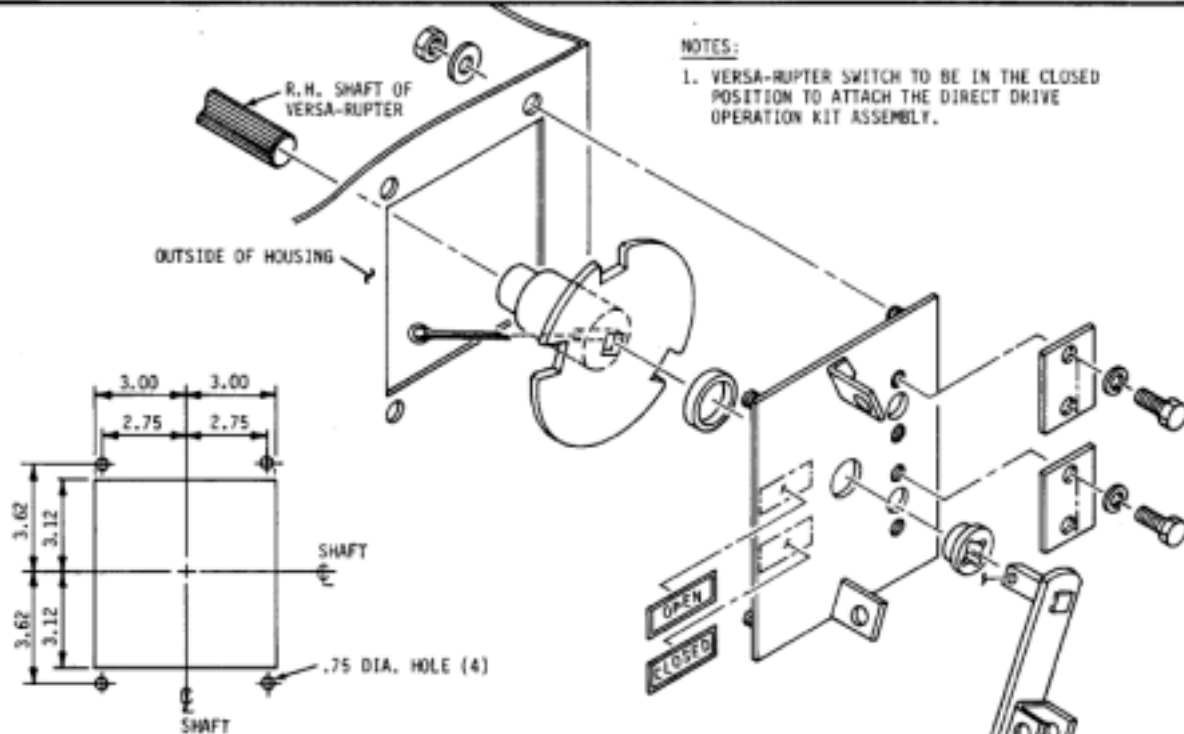

CUTOUT & DRILLING PLAN

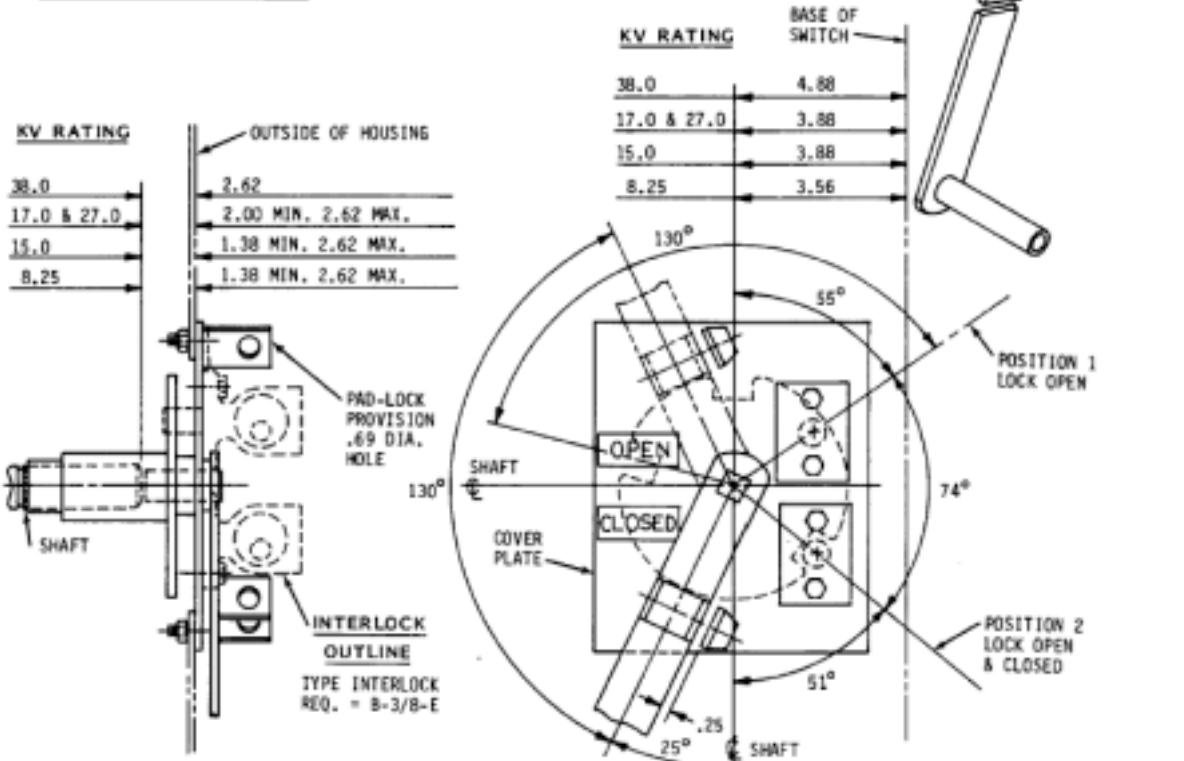

SHAFT TO HOUSING CLEARANCE

HANDLE TRAVEL & KIRK INTERLOCK LOCATION

FI-089 Rev. 0
Sht. 1

Versa-Rupter 15.0 Kv Fuse Frame Assy. Kit, Three Phase Set for CL-14 Fuses

OD-093 Rev. 0 Sht. 1

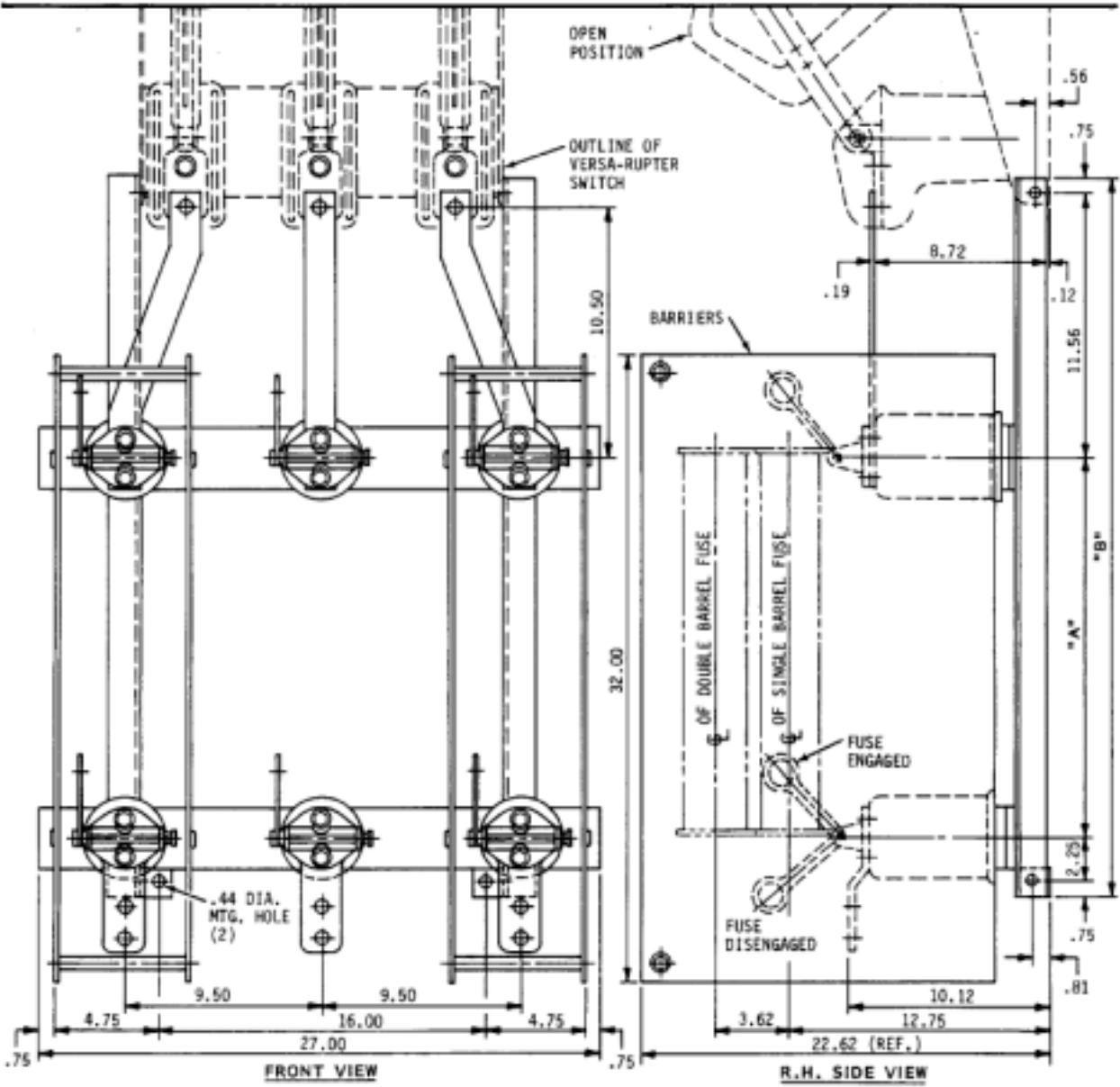

FUSE	"A"	"B"
10E TO 50E	18.25	33.56
65E TO 125E	21.25	36.56

OD-093
Rev. 0 Sht. 1

Versa-Hupter Mechanical Fuse Door Interlock

FI-094 Rev. 0 Page 1

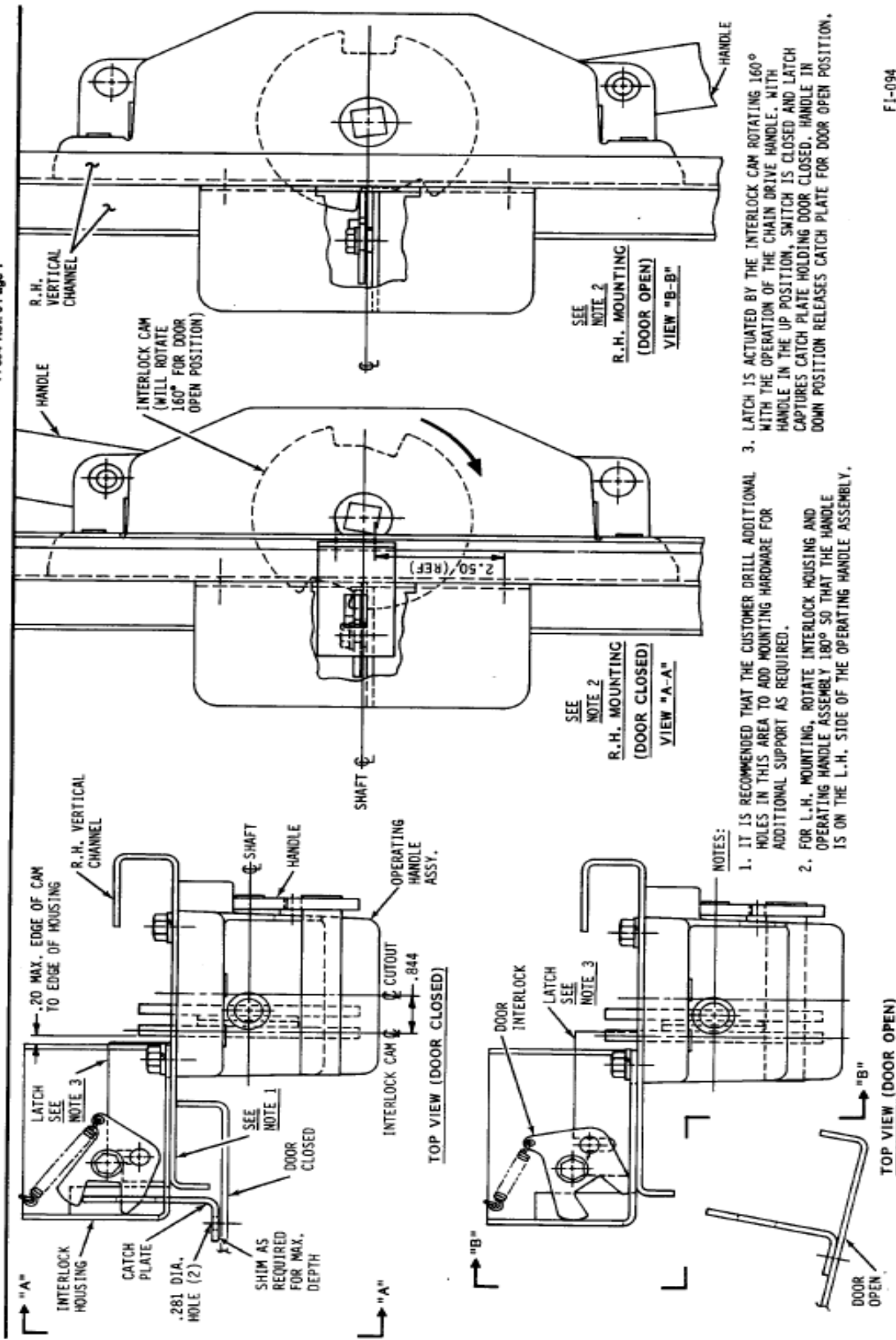

FI-094
Rev. 0 Sht. 1



ABB Power Distribution Inc.
Circuit Breaker Division



ABB Inc.

655 Century Point
Lake Mary, FL 32746 U.S.A.

For sales & marketing contact your
local representative or:

Tel: +1-407-732-2000
1-800-929-7947

Fax: +1-407-732-2161

www.abb.com/mediumvoltage