



SafeGear™

The most advanced ANSI arc-resistant
switchgear in the world

General overview

SafeGear meets today's challenge for improved safety and lower maintenance costs

No electrical system is foolproof. There's always a chance that insulation system deterioration, equipment malfunction or human error will result in an arc fault, with potentially catastrophic consequences.

When an arc fault occurs in conventional switchgear, the heat of the arc (10-20,000° K), can melt and even vaporize, compartment materials and components. Flames and hot gases escape and ignite nearby materials. As air temperature increases in the enclosed space, so does the pressure. The rapid pressure build-up is explosive, hurling objects such as doors, panels, and components.

Disastrous arc faults cost managers of large-power installations hundreds of thousands of dollars in lost equipment and down-time as well as needless deaths and injuries. The video excerpts below illustrate the consequences of an arc fault in conventional switchgear and the advantages of using SafeGear arc-resistant switchgear.

Arc-resistant metal-clad switchgear with ADVAC™ or AMVAC™ advanced design vacuum circuit breakers

SafeGear not only meets conventional standards for metal clad switchgear, it goes beyond ANSI standards to provide the protection of arc-resistant construction. Advanced arc-resistant construction reduces life cycle costs through equipment protection, and improves the safety of operations and maintenance personnel. During an arc fault, expanding hot gases are carefully routed through a system of vents and flaps, generally through the roof and away from personnel at the front, rear or sides of the switchgear. Doors and panels are reinforced and sealed to withstand the temporary pressure surge until relief vents and flaps operate. Using techniques such as double sidewall and type 2/2B/2C or 2BC construction, damage is contained in the compartment of fault origination, rather than spreading to adjacent compartments. Equipment damage is greatly reduced, other circuits can often stay on line, and tragic injuries to employees are prevented.

SafeGear arc-resistant construction is design tested under actual arc-fault conditions and in conformance to ANSI/IEEE C37.20.7-2007 standards to verify:

- 1) Cotton fabric test panels near the front, rear and sides do not ignite
- 2) Doors and panels remain secure, except for minor distortion
- 3) Components and molten materials are not hurled from the switchgear
- 4) The arc does not burn through to the LV compartment (type 2B)
- 5) The arc does not burn through to adjacent compartments (type 2C and type 2BC)
- 6) Ground connections remain intact

Conventional switchgear 50 kA interruption at KEMA Test Lab

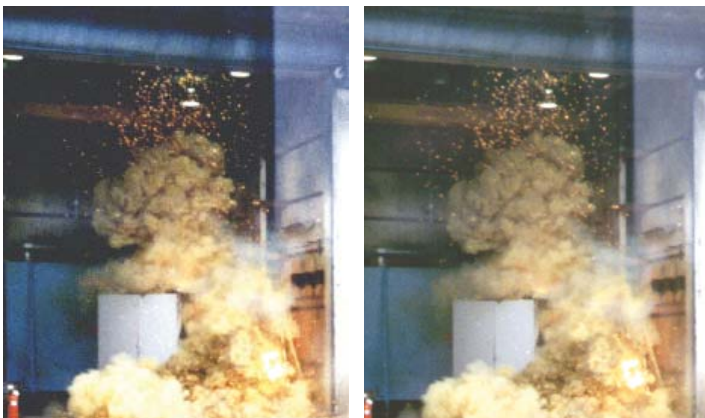

Arc-resistant switchgear 50 kA interruption at KEMA Test Lab

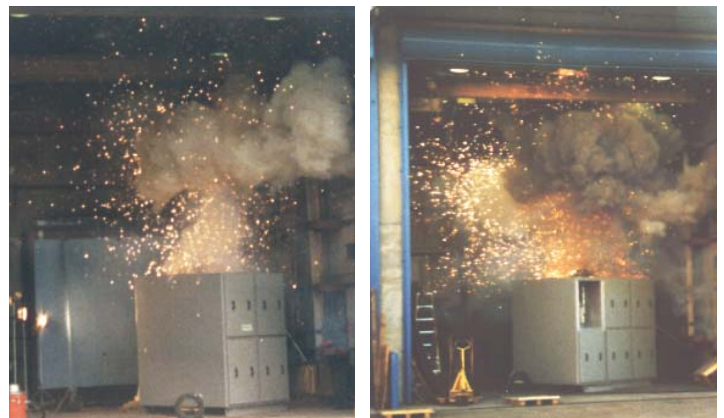

A system of chambers and tunnels inside the switchgear lineup serves as an exhaust system, venting gases in the case of an arc fault away from personnel and the affected cubicle. Vents and flaps are located inside the chamber system and on top of the enclosure to release the pressure. ABB developed this design and holds patents on many of the construction details of this truly innovative concept.

Arc resistance and closed-door racking significantly reduces operator risk during the handling and operation of the equipment. Installation, maintenance and operations personnel recognize the sturdiness and benefit of the design. Insurance companies recognize the reduced operational risk with lower contract rates. Owners realize the gain from reduced loss of revenue due to improved reliability of the power system.



- 1 Each primary compartment – breakers, auxiliary transformers, main bus, and primary cable entrances – are designed with internal hinged flaps or vents to allow over-pressure and hot gases to escape in a carefully controlled manner through roof mounted plenum exhaust ducts – away from nearby personnel at the front, rear or sides of the switchgear.
- 2 Roof-mounted hinged flaps are engineered to open quickly as pressure increases in an arc fault condition.
- 3 Stationary primary contacts accept self-aligning tulip disconnects mounted on the breaker.

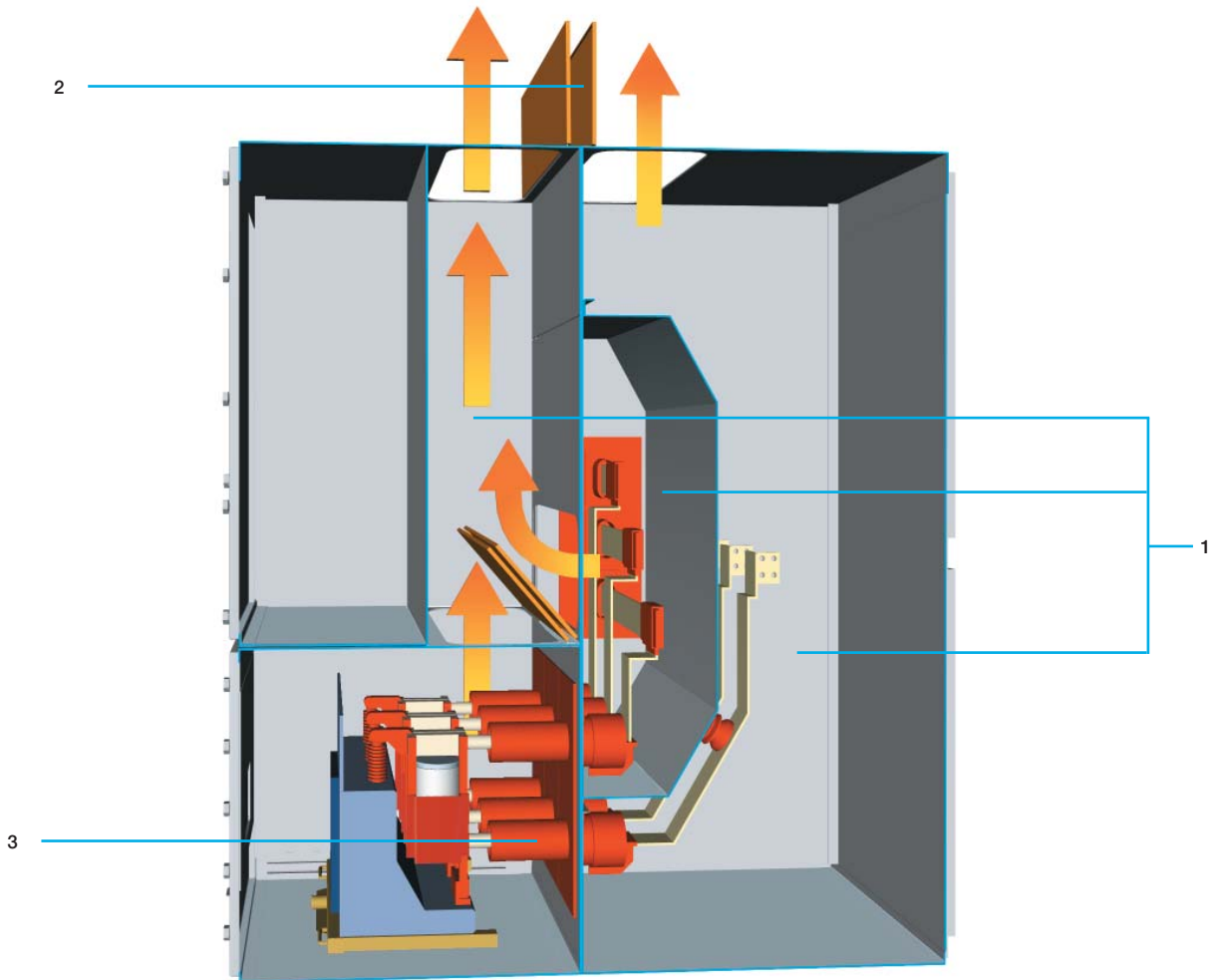

Venting flaps and chimneys release excessive pressure during an arc event. Front, side and rear structures maintain their integrity.

The **ABB multifunction relays** provides 3-phase protection and metering in a single device with communications capability. The multifunction capabilities of ABB multifunction relays result in a space-saving instrumentation package that enables arc-resistant switchgear construction in a 2-high configuration.

The optional ABB REA arc mitigation system is second to none when it comes to reliability: continuous self-monitoring of the system, and its fiber-optic loops ensure non-stop protection. Flexible overcurrent monitoring allows both light or light and overcurrent condition to trigger a circuit breaker for absolute security. Furthermore, the system can be installed in either retrofit installations or greenfield investments. Selective indication and zone-divided protection are easy to implement. Extension units allow single feeders or bus bars to be isolated, maintaining the power supply even in the event of an arc incident.

Functions and features include:

- 1) Extremely short overall operating time (<2.5 ms)
- 2) Fast, adjustable three-phase overcurrent or two-phase overcurrent and neutral current condition to secure tripping
- 3) Long-sensor fiber or light collecting lens type sensors
- 4) Current measurement with existing CTs
- 5) Circuit breaker failure protection
- 6) Continuous self-supervision of sensor fiber loops, operating voltages and cabling between central units and extension units
- 7) Wide area automatic or manual backlight compensation
- 8) Low-power consumption of 9-12 watts



- 1 Dedicated instrument compartments isolate low voltage circuits and instrumentation from compartments with primary circuits.
- 2 Doors on breaker, PT and CPT compartments are reinforced with channel steel. Special hinges and multiple-point latches add to compartment security, preventing flames from escaping and igniting nearby materials in arc fault conditions.
- 3 Double sidewall construction provides superior resistance to burn-through. A small air gap between compartments enables heat dissipation from an arc that would otherwise burn through equivalent single wall thickness.
- 4 Breaker compartment doors have large windows that enable viewing of breaker status indicators, including open/closed flags, spring charged status, and the operations counter. The windows can be omitted for customers who prefer solid steel door construction.
- 5 Closed-door racking capability maintains the integrity of arc-resistant construction by allowing the breaker to be inserted or withdrawn while the arc-resistant compartment door remains closed.

Venting chamber system allows arc-resistant construction with two-high arrangements for safe and compact power distribution equipment.

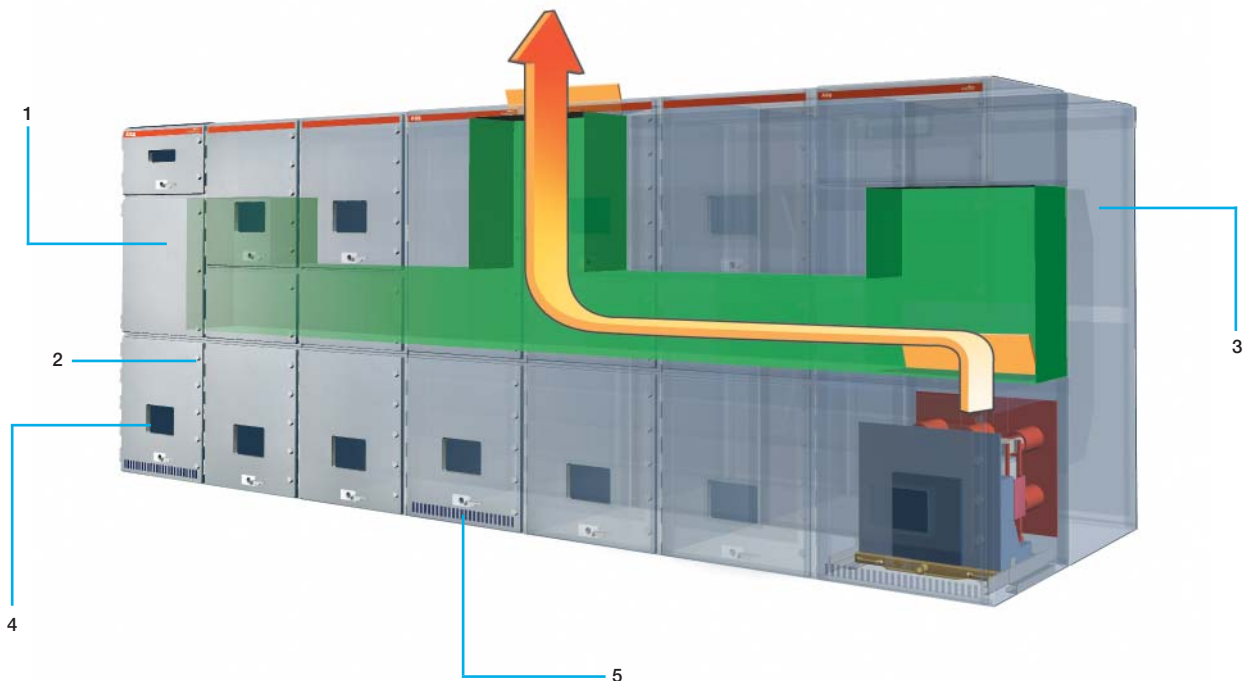

Front view of ADVAC circuit breaker

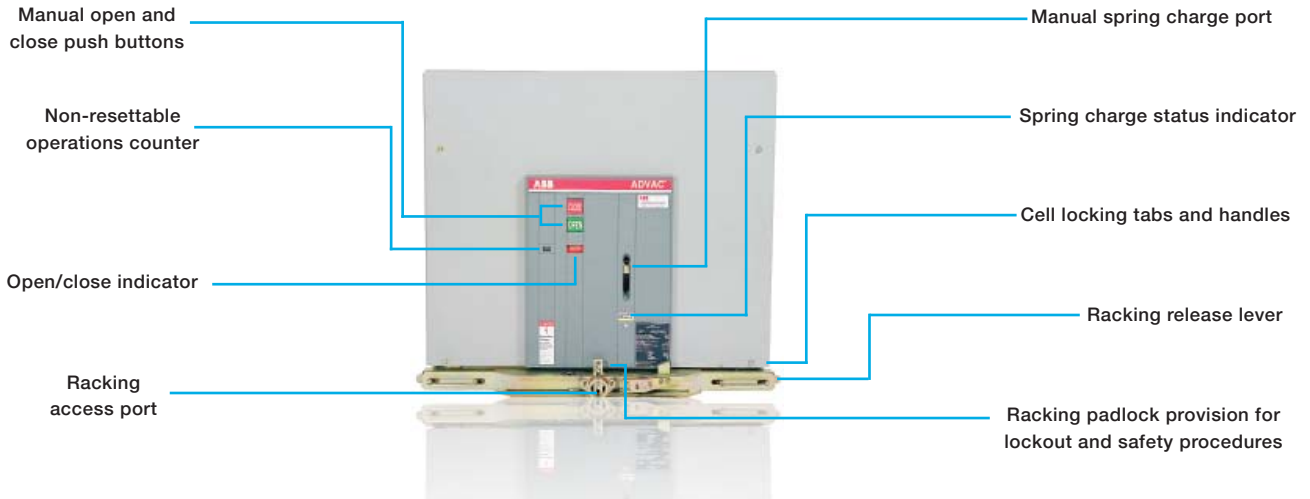

ADVAC circuit breaker with front panel removed

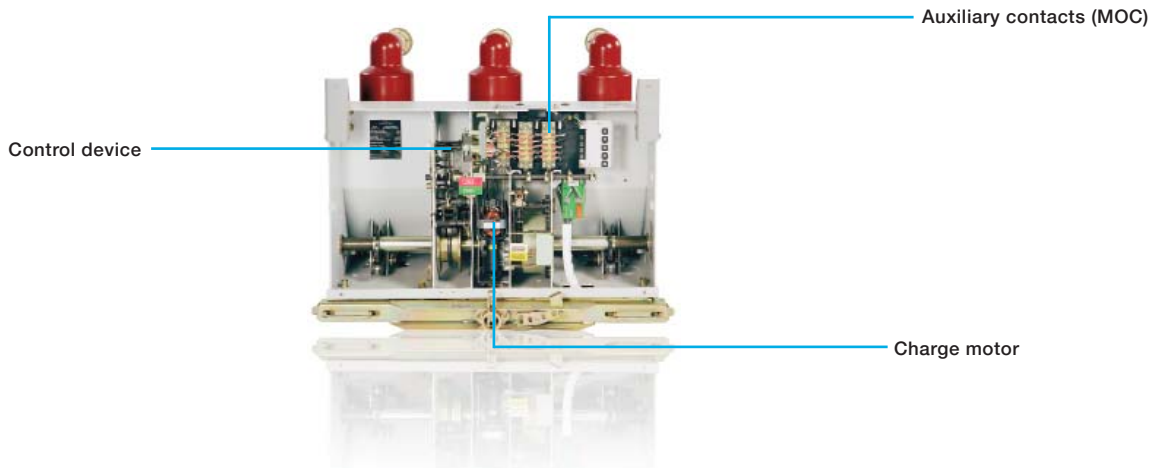

Rear view of ADVAC circuit breaker

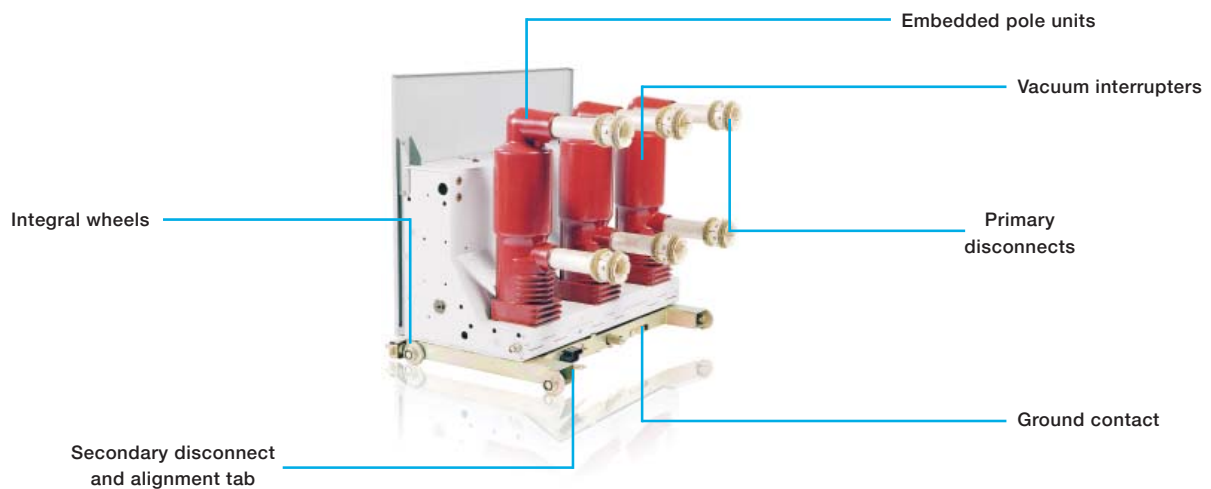

AMVAC circuit breakers

The next generation of circuit breakers

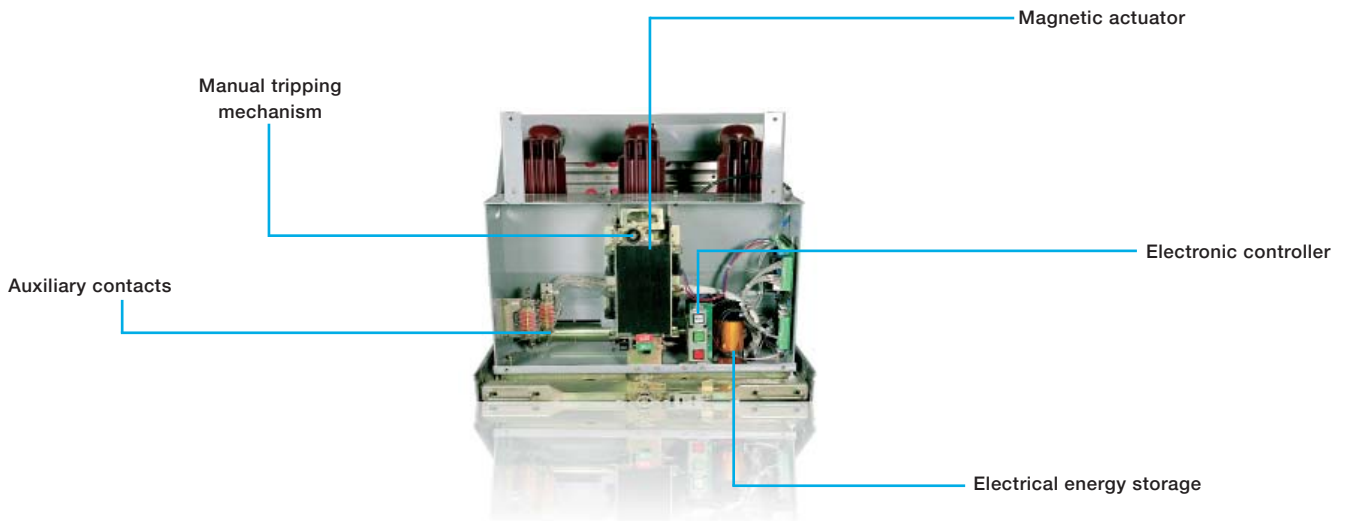

With the AMVAC, ABB is the first to combine the unique requirements of vacuum interrupter technology with a stored energy mechanism. Using a flux-shifting device with integral permanent magnets, the AMVAC mechanism has just one moving part. Having only open and close coils, an electronic controller, and capacitors for energy storage, the AMVAC circuit breaker mechanism is capable of 100,000 operations. Vacuum interrupters are pole-embedded in a proprietary epoxy material, achieving excellent dielectric and thermal capabilities. Eliminating mechanism operated cell switches, the AMVAC breaker packages all auxiliary control contacts on the circuit breaker.

Ratings

AMVAC is available in the full range of ANSI and IEEE ratings. Through 15 kV, it has interrupting ratings to 50 kA and continuous currents through 3000 A (self-cooled) or 4000 A (forced-air-cooled). AMVAC and ADVAC circuit breakers have been fully tested to the most recent versions of ANSI/IEEE C37.04, C37.06, and C37.09. Using “k” factor equals 1 as the test criteria.

Universal applications

- Medium voltage motor starting applications
- Capacitor switching
- Retrofit applications to replace existing circuit breakers in repetitive duty applications
- Mining applications where high reliability and resistance to dust and humidity are critical

AMVAC specifications

- Interchangeable with ADVAC
- Completely concealed moving parts
- UL labeling and CSA compliance
- Low power consumption
- ANSI/IEEE compliance at 5 and 15 kV

Summary of benefits

- Simple mechanical operation
- Seven moving parts
- Manual opening capability
- High reliability

Technical specifications & application data

(Ratings on 60 Hz basis)

AMVAC & ADVAC* circuit breaker rating structure

AMVAC breaker type	ADVAC breaker type	Nominal voltage class kV	Rated maximum voltage kV	Low frequency withstand voltage kV rms	Impulse level (BIL) kV crest	Rated short circuit current kA rms	Short time current kA rms 2 sec.	Close and latch kA peak	Rated voltage range factor K
5AMV25	5ADV25	4.16	4.76	19	60	25	25	82	1.0
5AMV31	5ADV31	4.16	4.76	19	60	31.5	31.5	82	1.0
5AMV40	5ADV40	4.16	4.76	19	60	40	40	104	1.0
5AMV50	5ADV50	4.16	4.76	19	60	50	50	130	1.0
7.5AMV40	7.5ADV40	7.2	8.25	36	95	40	40	104	1.0
15AMV20	15ADV20	13.8	15	36	95	20	20	52	1.0
15AMV25	15ADV25	13.8	15	36	95	25	25	65	1.0
15AMV31	15ADV31	13.8	15	36	95	31.5	31.5	82	1.0
15AMV40	15ADV40	13.8	15	36	95	40	40	104	1.0
15AMV50	15ADV50	13.8	15	36	95	50	50	130	1.0

*ADVAC circuit breakers are available in continuous current ratings of 1200, 2000 and 3000 A rms. A force cooled 4000 A rating is also available. Ratings are 50/60 Hz basis. Higher dielectric ratings are available for most classes.

Definite purpose ratings

Rated maximum voltage kV rms	Rated short-circuit current ka rms	ADVAC and AMVAC continuous current rating*			
		1200 A		2000 A	
		General purpose	Definite purpose	General purpose	Definite purpose
4.76	31.5	400	630	400	1000
4.76	40	400	630	400	1000
4.76	50	400	630	400	630
8.25	40	250	630	250	1000
15.0	25	250	630	250	1000
15.0	50	250	630	250	630

Notes: Ratings are subject to the following conditions:

- 1) The transient voltage from line to ground shall not exceed three times maximum design line to ground crest voltage measured at the breaker terminals.
- 2) The number of restrikes or reignitions shall not be limited as long as the transient voltage to ground does not exceed the value given in Note 1.
- 3) The capacitor rating applies only to "Single Bank Switching" as noted herein.
- 4) Interrupting time is in accordance with the rated interrupting time of the circuit breaker.

* Contact factory for 3,000 A rating.

ADVAC*

Nominal coil voltage (V)	Trip coil		Close coil		Impedance +/- 5% (Ohms)	Recommended class RK-5 fuse size (A)
	Rated voltage range (V)	Nominal current (A)	Rated voltage range (V)	Nominal current (A)		
24 VDC	20-28	9.6	-	-	*	15
48 VDC	28-56	4.8	38-56	4.8	47	15
125 VDC	70-140	3.0	100-140	3.0	198	15
250 VDC	140-280	1.5	200-280	1.5	8	15
120 VAC	104-127	3.0	104-127	3.0	198	15
240 VAC	208-254	1.5	208-254	1.5	8	15

*Contact factory for impedance value.

AMVAC

	Control power voltage range	Tripping voltage range	Closing voltage range	Capacitor charging	Continuous power
Low voltage board	20 - 53 VAC	20 - 264 VAC	20 - 264 VAC	100 watts	10 watts
	17 - 75 VDC	20 - 264 VDC	20 - 264 VDC	100 watts	10 watts
High voltage board	85 - 264 VAC	20 - 264 VAC	20 - 264 VAC	100 watts	10 watts
	77 - 280 VDC	20 - 264 VDC	20 - 264 VDC	100 watts	10 watts

ADVAC charging motor

Charge motor	Nominal voltage range (V)	Nominal current (A)	Inrush current	Stalled current (A)	No load current (A)	Charging time (nominal)	Recommended class fuse size (A)
48 VDC	38-56	8	6-8 x nominal current	25.0	3.5	8-9 seconds	15
125 VDC	100-140	4		12.5	1.5		
250 VDC	200-280	2		6.5	0.8		
120 VAC	104-127	4		12.5	1.5		
240 VAC	208-254	2		6.5	0.8		

Timing characteristics

	ADVAC	AMVAC
Nominal closing time	60 ms	45-60 ms
Nominal opening time	35-40 ms	35-45 ms
Arcing time	< 15 ms	< 15 ms
Nominal interrupting time	< 55 ms	< 55 ms
Motor charging time	8-9 seconds*	N/A
Manual charging time	~25 seconds**	N/A

*At nominal control voltage

**Requires approximately 25 strokes of charging handle

ADVAC (featured below) and AMVAC circuit breaker dimensions are similar for all 36-inch wide compartments and ratings. The operating mechanism, control components, racking system and accessories are the same for all ratings. Breakers with higher interrupting and continuous current ratings use various primary lead assemblies and interrupter housings with different appearances, but cell interface dimensions are identical.



ABB Medium Voltage switchgear values

1 SafeGear offers arc-resistant design

- Type 2=4 walls protection
- Type 2B = Type 2 plus instrument compartment personnel protection
- Type 2C = Type 2 plus compartment to compartment switchgear protection
- Type 2BC = combines the protection of Types 2, 2B, and 2C

2 REA arc flash relay utilizes arc flash mitigation

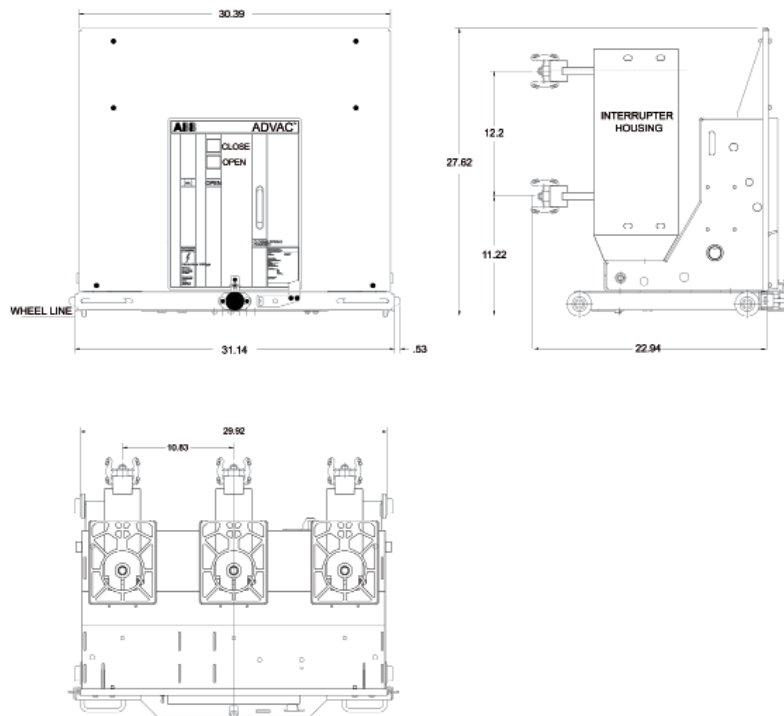
- Up to 2.5 millisecond detect time
- Up to 80% arc flash energy reduction
- Light and current detection
- Lowers level of required Personal Protective Equipment (PPE) to work on switchgear

3 AMVAC needs virtually no maintenance

- Affords the best personnel protection
- Save money by eliminating annual maintenance
- Magnetically actuated breaker
- Only seven moving parts
- Three times longer life than traditional MV breakers

4 SafeGear provides 2.5 square feet of savings

- Smallest footprint in industry
- Smaller Power Distribution Center (PDC) saves on construction and shipping costs

1



3



2



4

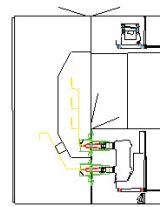

2000 A W/1 VT UNIT

2.5
square feet
SAVINGS

ABB:	85"
Competitor:	95"
Competitor:	112"

Modular construction

Results in fast delivery of arc-resistant metal-clad switchgear in custom configurations

Modules are stackable in a variety of one-high and two-high configurations. SafeGear allows the arrangement of one or two sets of voltage transformers on top of a circuit breaker, minimizing required floor space.

ABB uses a bolted construction design that makes installation in the field quicker and easier than traditional switchgear construction. It also allows for easier upgrades and repairs in the field for faster and more affordable operations.

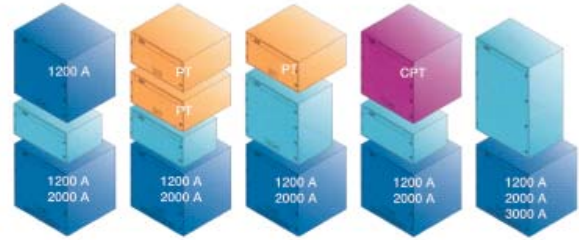

Overall dimensions per frame: 36"W x 95"H x 85"D

SafeGear 5, 7.5 & 15 kV 36 kA and above Single Frame Cubicle Arrangements

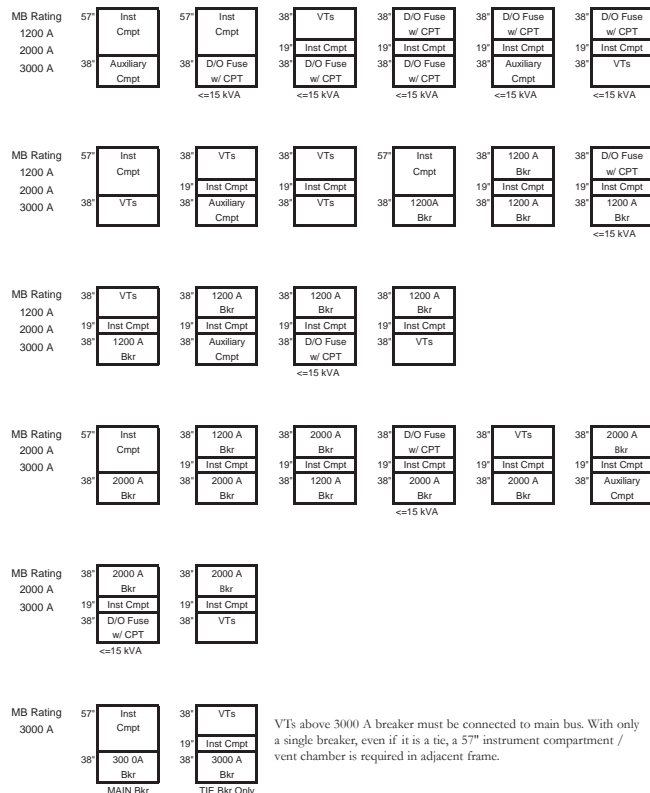

Note: Each line-up must contain one 57" instrument compartment. CPTs greater than 15 kVA require a drawout fuse unit with stationary mounted CPT in the rear.

SafeGear 5, 7.5 & 15 kV 31.5 kA and below Single Frame Cubicle Arrangements

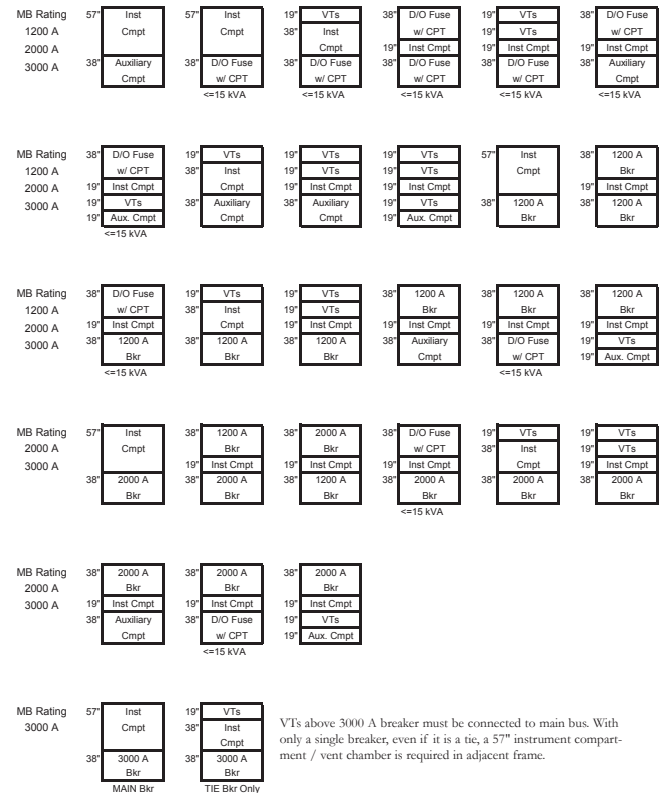

Note: Each line-up must contain one 57" instrument compartment. CPTs greater than 15 kVA require a drawout fuse unit with stationary mounted CPT in the rear.

Contact us

ABB Inc.

655 Century Point

Lake Mary, FL 32746

Phone: +1 407 732 2000

Customer service: +1 800 929 7947 ext. 5

+1 407 732 2000 ext. 2510

E-Mail: customer.service.group@us.abb.com

www.abb.com/mediumvoltage

All sales are subject to ABB Inc.
General Terms and Conditions of Sale.

While every effort has been made to assure accuracy, the
information in this document is subject to change without
notice.

© Copyright 2010 ABB Inc. All rights reserved.