

Technical Guide

VersaRupter MV indoor switch 5-38 kV, 200-1200 A, 40 & 61 kA price and order entry guide

Table of contents

VersaRupter overview	3
Technical data	4
Weights and dimensions drawing	6
Weights and dimensions table	7
VersaRupter switch selection guide	8
Operating mechanism	9
VersaRupter price and order entry worksheet.....	10
Snap action mechanisms (K-mechanism)	11
Stored energy mechanisms (A-mechanism)	12
Electrical control options	13
Operating Handles	14
Chain drive handles without door interlock.....	15
Chain drive handles with mechanical door interlock.....	16
Direct drive handle / type HE shaft drive operator	17
Motor operator option	18
Optional accessories (to be ordered seperately)	19
Fuse options.....	21
Type CEF Fuses.....	22
Miscellaneous accessories and renewal parts.....	24
Notes	25

VersaRupter overview

General description

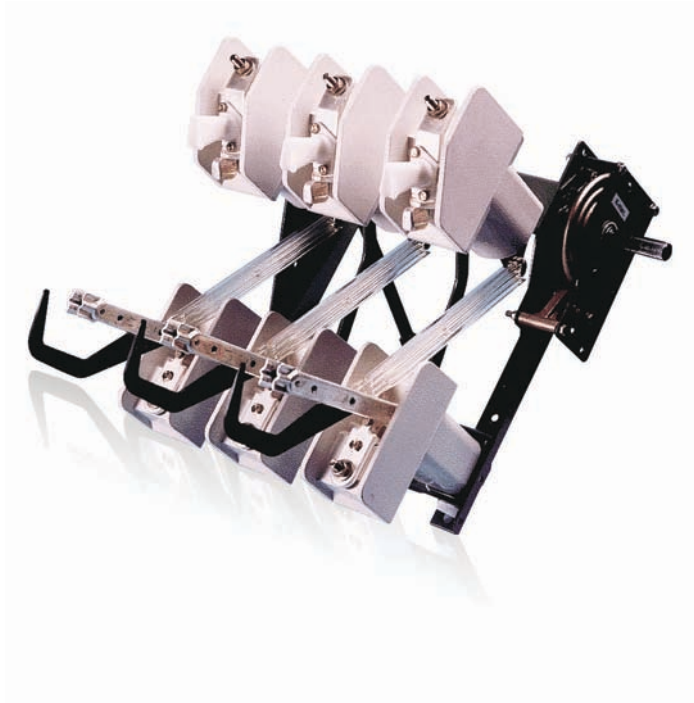

VersaRupter assembled with snap action k-mechanism

VersaRupter is a general purpose, three-pole, loadbreak switch that offers switchgear owners and assemblers the advantages of an advanced interrupting technology and proven, dependable performance in a compact design. The switch is available to switchgear assemblers as a building block for metal-enclosed and padmounted switchgear applications in ratings from 5 – 38 kV.

- Puffer arc extinguishing system allows for a high number of operations without excessive wear
- Lack of gravity dependent latches allows for flexible mounting arrangements
- Tight phase spacing without the requirement for inter-phase barriers
- Compact operating mechanisms available in stored energy or snap action varieties
- Compact motor operator provides local or remote control of VersaRupter

The standard VersaRupter switch includes a heavy-duty steel frame with stand-off insulators, a unique puffer type arc extinguishing system, an operating mechanism and current-carrying components, including blade-type interrupters with cast hinges and jaw connectors. Optional accessories and features include a variety of operating handles, a motor operator, auxiliary switches, a shunt trip device, fuse bases, mechanical fuse tripping, grounding switches, mechanical door interlocking and key interlocking.

VersaRupter at a Glance

Applications	Metal-enclosed and padmount switchgear for utility distribution, capacitor switching, industrial, mining and commercial installations		
Ratings	Voltage	Loadbreak Current	Momentary
	5-27 kV	200, 600 & 1200 A	40 kA momentary / 40 kA fault close
	38 kV	600 & 800 A	40 kA momentary / 30 kA fault close
	15-15.5 kV	600 & 1200 A	61 kA momentary / 61 kA fault close
Standards	ANSI C37.20.4 IEC 60129, 60254, 60265, 60694, 420, 62271-105 For UL listings see Tables 1A and 1B		
Experience	Over 600,000 switches installed in over 50 countries worldwide		
Actuators	Manual operation with choice of direct side drive, front chain or front shaft drive Optional motor operation, optional shunt trip with A-mech only Left or right side mounting available with most options		
Options	Grounding switch, fuse base, mechanical fuse tripping, auxiliary switches, key interlocks		
Quality	ISO-9001 Complete ANSI design test reports Switches are tested to a minimum of 1000 mechanical operations, 100 open/close operations up to 630 A, and 20 open/close operations at 1200A		

Technical data

VersaRupter Switch - Technical Details

Rated Voltage (kV)	Rated Maximum Voltage (kV)	Rated Current (A)	BIL (kV)	60 Hz Withstand 1 minute (kV)	Pole Spacing (in/mm)	Momentary asymmetrical (kA)	Fault-closing asymmetrical (kA)	Short time current symmetrical (kA/sec)
4.73	8.25	200	75	26	5.91/150	40	40	25/3
		600						
		1200						
12-13.8	15	200	95	36	6.69/170	40	40	25/3
		600						
		1200						
13.8	15	200	95	36	9.25/235	61	61	40/3
		600						
		1200						
12-16.5	17	200	110	50	9.25/235	40	40	25/2
		600						
		1200						
23.9-24.9	27	200	125	60	10.8/275	40	40	25/3
		600						
		1200						
34.5	38	600	150	80	14.1/360	40	30	25/2
		800						
UL Listed								
4.73	8.25	200	75	26	5.9/150	40	40	25/3
		600						
13.8	15	200	95	36	6.69/170	40	40	25/3
		600						
13.8	15	200	95	36	9.25/235	40	40	25/3
		600						
13.8	15	600	95	36	9.25/235	61	61	40/3
		1200						

Capacitor bank switching for 15 kV switches (kVar) 2500

Maximum torque at closing (ft-lbs) 85 - 89

Maximum torque at opening K-mech (ft-lbs) 89

Maximum torque at opening A-Mech (ft-lbs) 2.2

Operating rotation of shaft (degrees) 130

Arc time (ms) 10 - 20

Opening time (ms) 40 - 60

Technical data (continued)

Technical Data Shunt Trip Device				
Nominal Coil Voltage	Voltage Range	Average current (Amps)		Power (VA)
		IN	Istart	
24 VDC	-15% to +10%	10.0	10.0	240
48 VDC	-15% to +10%	2.4	2.4	115
110 VDC	-15% to +10%	1.4	1.4	155
220 VDC	-15% to +10%	1.5	0.5	110
110 VAC	-15% to +10%	2.7	5.0	300
220 VAC	-15% to +10%	1.5	2.8	320

Manual operation with NM motor

The NM motor operator allows manual operation of the VersaRupter via a direct shaft drive HM operator with removable handle (chain drive and side direct drive handles cannot be used). The NM motor operator does not have to be electrically cycled after a manual operation of the VersaRupter; it will automatically resume proper electrical operation in the proper position. The NM motor operator requires a motor contactor/relay assembly (3" x 3" x 8"), which may be mounted in the switch enclosure or an adjacent vertical section.

Voltage AC/DC $\pm 10\%$	24 V	48 V	60 V	110 V	220 V
Current (A)	33	3	0.8	0.8	0.4
Power Consumption (W)	70	140	45	85	90
Operating time (sec)	~4	~2	~8	~4	~4
Operating temperature (°F)	-40 to 131	-40 to 131	-40 to 131	-40 to 131	-40 to 131
Signaling time (sec)	0.5 - 2.0	0.3 - 1.0	1.0 - 4.0	0.5 - 2.0	0.5 - 2.0
Weight (lbs) (kg)	13.2 (6)	13.2 (6)	13.2 (6)	13.2 (6)	13.2 (6)

Weights and dimensions drawing

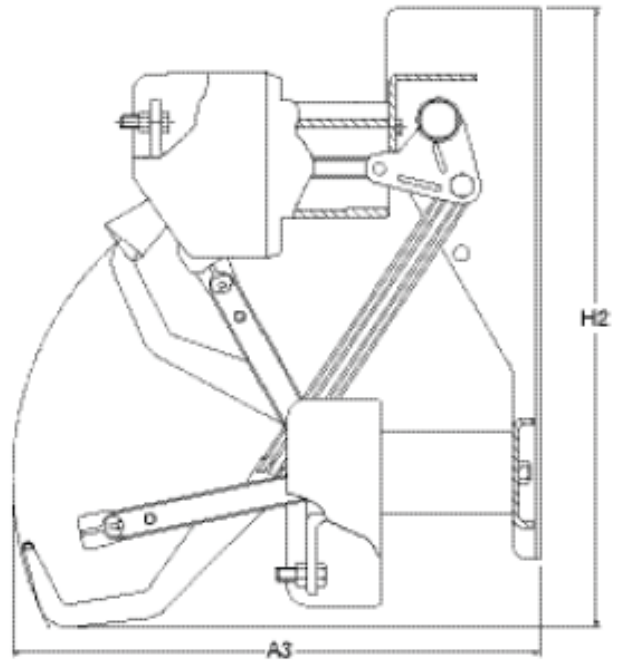
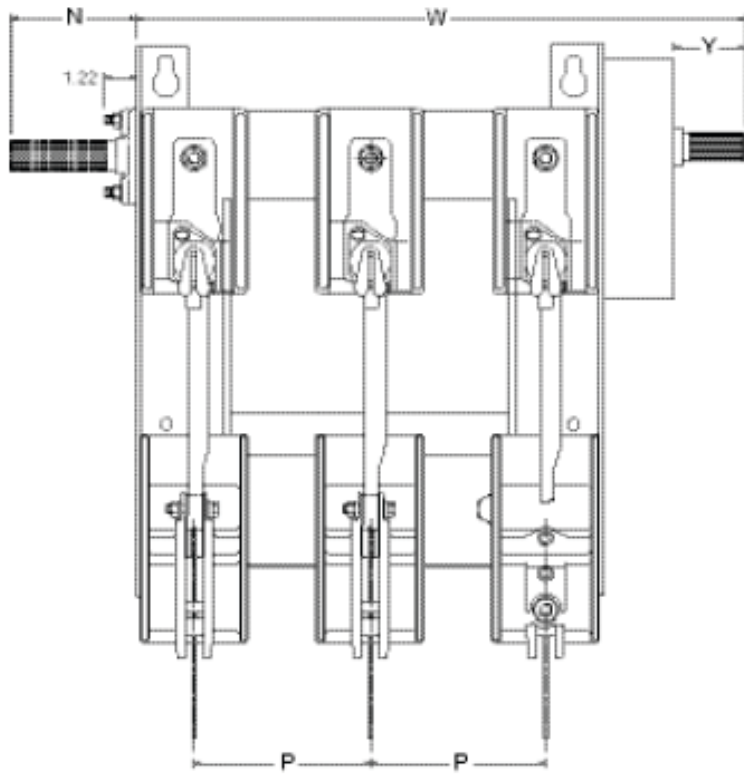

Reference drawings for dimensions table on page 7

Weights and dimensions table

Dimensions (Inches)			Width ¹ (W)	Height (H2)	Depth (A3)	Optional Shaft Ext. (N)	Weight Lbs.	Ref. Drawing		
Switch Max kV / Phase Spacing										
8.25 kV P = 5.91" (150 mm)	200 A	K-mechanism	22.68	20.08	15.51	4.80	71	S-20183		
		A-mechanism	22.41							
	600 A	K-mechanism	22.68							
		A-mechanism	22.41							
	1200 A	K-mechanism	22.68						22.41	S-20214
		A-mechanism	22.41							
15 kV P = 6.69" (170 mm)	200 A	K-mechanism	24.25	23.62	20.12	4.80	75	S-20184		
		A-mechanism	23.98							
	600 A	K-mechanism	24.25							
		A-mechanism	23.98							
	1200 A	K-mechanism	24.25						23.98	S-20215
		A-mechanism	23.98							
15 kV (61 kA) 15.5 kV (61 kA) P = 9.25" (235 mm)	600 A	K-mechanism	29.37	24.17	21.55	7.32	110	S-20346		
		A-mechanism	29.10							
	1200 A	K-mechanism	29.37							
		A-mechanism	29.10							
17 kV P = 9.25" (235 mm)	200 A	K-mechanism	29.37	23.62	20.12	7.32	93	S-20348		
		A-mechanism	29.10							
	600 A	K-mechanism	29.37							
		A-mechanism	29.10							
	1200 A	K-mechanism	29.37						29.10	S-20215
		A-mechanism	29.10							
27 kV P = 10.8" (275 mm)	200 A	K-mechanism	32.52	23.62	20.12	7.32	95	S-20347		
		A-mechanism	32.25							
	600 A	K-mechanism	32.52							
		A-mechanism	32.25							
	1200 A	K-mechanism	32.52						32.25	S-20215
		A-mechanism	32.25							
38 kV P = 14.1" (360 mm)	600 A	K-mechanism	46.61	34.25	33.46	10.08	220	NHP 241285		
		A-mechanism	46.34							
	800 A	K-mechanism	46.61							
		A-mechanism	46.34							

¹Width for K-mechanism based on standard shaft (K3) where Y dimension = 3.77"

Other options are: K2 snap action mechanism where Y = 2.69"

K5 snap action mechanism where Y = 5.26"

¹Width for A-mechanism based on standard shaft (A3) where Y dimension = 3.50"

Other options are: A4 stored energy mechanism where Y = 4.80"

A6 stored energy mechanism where Y = 6.90"

Note: See definitions for K&A mechanisms on page 9.

VersaRupter switch selection guide

Style number reference

The VersaRupter switch product line has a structured, smart style number ordering system. The complete style number is built up of 18 customer selection characters. Each character identifies features or functions that can be incorporated into the switch application. The first nine characters of the style number define the basic switch. The next two characters define electrical control options. The next four characters are used to define handle operator options and the final four define motor operator

requirements.

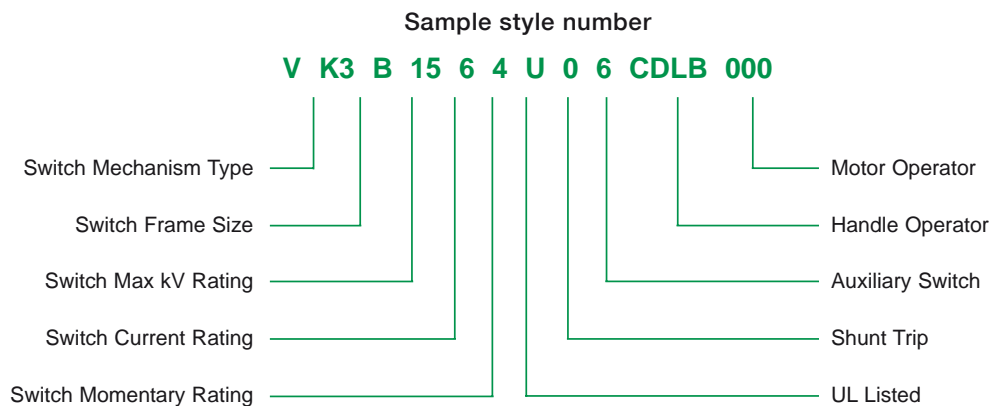

How to order

Select the required option codes to fill in the smart style number. The total List Price (USD) is computed by adding the individual List Price (USD)s for each of the selections.

Step 1: Select basic switch (characters 1 – 9)

Study the mechanism selection guide on page 9 to determine which mechanism is compatible with the features you require. Then select the 9 character switch smart style number code from Table 1A (K-mechanism) or Table 1B (A-mechanism).

Step 2: Select shunt trip and auxiliary switch options (characters 10 & 11)

Select codes for the desired electrical control options from Tables 2 and 3 (page 13).

Step 3: Select handle operator options (characters 12 – 15)

Study the handle operator guide on page 14 to review features offered and compatibility.

Select the smart style number code for the desired handle operator and location from the appropriate tables 4,5,6, or 7 on pages 15, 16 and 17.

Note: If no handle is required this field is filled with zeros “0000”.

Step 4: Select motor operator options (characters 16 – 18)

Select the desired motor operator and location code from Table 8 on page 18.

Notes: 1) If no motor is required this field is filled with zeros “000”

2) Pole spacing on Table 8 must match pole spacing for digits selected in Table 1A or 1B.

Step 5: Identify other optional accessories to be ordered as separate items

See Table 9 for ground switches.

Pole spacing for ground switches must match that in Table 1A or 1B for which ground switch will be applied to. When ground switches are selected, a mechanical interlock must also be selected that matches pole spacing as well.

See Tables 10 – 13 for fuse bases.

Fuse bases not available for 1200A switches.

See Table 14 for CEF fuses.

See page 24 for back connection kit and other accessories.

Operating mechanism

Selection guide

Snap action K-mechanism

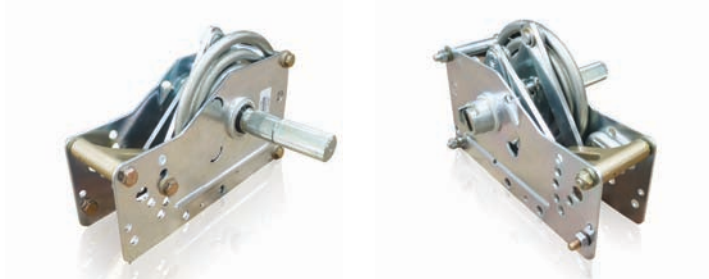

The K-mechanism is a single spring snap action device. The switch opens or closes by charging the spring past dead center using one of the manual operating handles. The K-mechanism may be used with all handle options as well as with type NM motor operators. The K-mechanism cannot be used for shunt trip or fuse trip applications.

- Use K-mechanism if you need chain drive or side direct drive handles.

Stored energy A-mechanism

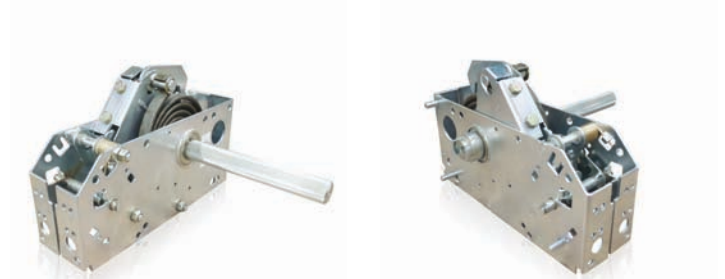

The A-mechanism is a dual spring stored energy device that is well suited for remote tripping applications. When shunt tripping or mechanical fuse tripping is specified, the type A-mechanism must be used. In closed operation, the opening spring is charged and latched by an operating handle or by a motor operator. The VersaRupter is then opened by any or several methods:

- Movement of the operating handle
- Motor operator
- Electrical signal to a shunt trip device
- Mechanical fuse tripping linkage

Operating features and functions

		Mechanism type			
		Snap action K-mech		Stored energy A-mech	
		40 kA	61 kA	40 kA	61 kA
UL recognized		X	X		X
Electrical control options	Remote shunt trip ¹			X	X
	Auxiliary switch available	X	X	X	X
	Fuse auxiliary switch			X	
Operating handles	Side direct drive	X	X		
	Front shaft drive-Type HE ²	X	X	X	X
	Front chain drive	X	X		
Motor operator (optional)	NM-side or shaft mounted ³	X	X	X	X
Interlocks	Mechanical door interlock	X	X		
	Key interlock	X	X		
Grounding switch	Type E ground switch	X		X	
	Ground switch interlock with VersaRupter	X		X	
Fuse options	Fuse bases available	X		X	
	Mechanical fuse tripping ⁴			X	

¹ Shunt trip option provides for operation by local push button or remote signal. Shunt trip requires stored energy type A-mechanism.

² The HM drive must be used if manual operation is needed in conjunction with motor operator.

³ Chain and direct drive handles cannot be used with motor operators.

⁴ This feature provides for the switch to open if a fuse operates.

VersaRupter price and order entry worksheet

Complete Switch

Switch Smart Style Number

V																	
1	2	3	4	5	6	7	8	9	10	11	12	13	14	15	16	17	18
												Smart Code			List Price (USD)		
Step 1: Select basic switch with operating mechanism from tables 1A or 1B (required) Enter 9 character smart number (digits 2-9) & List Price (USD)																	
Step 2: Select shunt trip option from Table 2 (Optional) Enter "0" if none required (digit 10)																	
Step 3: Select auxiliary switch option from Table 3 (Optional) Enter "0" if none required (digit 11)																	
Step 4: Select 4 character handle operator from Tables 4, 5, 6, or 7 (Optional) Enter "0000" if none required (digits 12 - 15)																	
Step 5: Select 4 character number for motor operator from Table 8 (Optional) Enter "0000" if none required (digits 16 - 19)																	
Step 6: Total List Price (USD)s and apply multiplier to calculate net price												Total List Price (USD)					
Enter complete smart switch style number to top of page												Enter multiplier					
												Calculate net price					

Other Accessories (Order as separate line items)

Description	Catalog Number	List Price (USD)	Multiplier	Net Price
Removable Handle (Table 7)				
Grounding Switch (Table 9)				
Grounding Switch Interlock (Table 9)				
Fuse Base (Tables 10 - 13)				
Fuses (Table 14)				
Back Connection Kit (Table A1)				
Shaft Extensions (Table A2)				
Splined Tubes (Table A2)				

Operating mechanism (continued)

Snap action mechanisms (K-mechanism)

K-mechanism switches must be selected when chain drive or side direct drive handles are required.

Table 1A: VersaRupters with Snap Action Mechanisms (K-mechanism)

System Rating Nominal (kV)	Rated Voltage Max. (kV)	Rated BIL (kV)	Continuous & Loadbreak (A)	Momentary Rating (RMS kA)	Fault Close Rating (RMS kA)	UL	Smart Style Code	List Price (USD)
4.73 [5.9" (150 mm) pole spacing]	8.25	75	200	40	40	No	VK3A0824N	\$1,078
			200			Yes	VK3A0824U	\$1,134
			600			No	VK3A0864N	\$1,198
			600			Yes	VK3A0864U	\$1,261
			1200			No	VK3A0814N	\$1,562
12-13.8 [6.69" (170 mm) pole spacing]	15	95	200	40	40	No	VK3B1524N	\$1,240
			200			Yes	VK3B1524U	\$1,305
			600			No	VK3B1564N	\$1,378
			600			Yes	VK3B1564U	\$1,450
			1200			No	VK3B1514N	\$1,756
13.8 [9.25" (235 mm) pole spacing]	15	95	600	61	61	Yes	VK3C1566U	\$1,925
			1200			Yes	VK3C1516U	\$2,139
14.4 [9.25" (235 mm) pole spacing]	15.5	110	600	61	61	Yes	VK3C1666U	\$2,133
			1200			Yes	VK3C1616U	\$2,630
12-16.8 [9.25" (235 mm) pole spacing]	17	110	200	40	40	No	VK3C1724N	\$1,258
			600			No	VK3C1764N	\$1,398
			1200			No	VK3C1714N	\$1,777
22.9-24.9 [10.8" (275 mm) pole spacing]	27	125	200	40	40	No	VK3D2724N	\$1,480
			600			No	VK3D2764N	\$1,646
			1200			No	VK3D2714N	\$2,046
34.5 [14.1" (360 mm) pole spacing]	38	150	600	40	30	No	VK7E3864N	\$3,422
			800			No	VK7E3884N	\$3,575

Smart style codes for UL recognized designs have "U" in the 9th digit position. Smart style codes for non-UL designs end with "N."
 Bold catalog numbers are UL recognized when used with chain drive handles and no motor operator.

Stored energy mechanisms (A-mechanism)

A-mechanism switches must be selected when shunt trip or mechanical fuse tripping is required.

Switches with A-mechanisms cannot be used with chain or side direct drive handles.

Table 1B: VersaRupters with Stored Energy Mechanisms (A-mechanism)

System Rating Nominal (kV)	Rated Voltage Max. (kV)	Rated BIL (kV)	Continuous & Loadbreak (A)	Momentary Rating (Asym kA)	Fault Close Rating (Asym kA)	UL	Smart Style Code	List Price (USD)
4.73	8.25	75	200	40	40	No	VA3A0824N	\$1,284
[5.9" (150 mm) pole spacing]			600			No	VA3A0864N	\$1,427
			1200			No	VA3A0814N	\$1,772
12-13.8	15	95	200	40	40	No	VA3B1524N	\$1,446
[6.69" (170 mm) pole spacing]			600			No	VA3B1564N	\$1,607
			1200			No	VA3B1514N	\$1,998
13.8	15	95	600	61	61	Yes	VA6C1566U	\$2,187
[9.25" (235 mm) pole spacing]			1200			Yes	VA6C1516U	\$2,512
14.4	15.5	110	600	61	61	Yes	VA6C1666U	\$2,568
[9.25" (235 mm) pole spacing]			1200			Yes	VA6C1616U	\$2,928
12-16.8	17	110	200	40	40	No	VA3C1724N	\$1,504
[9.25" (235 mm) pole spacing]			600			No	VA3C1764N	\$1,666
			1200			No	VA3C1714N	\$2,008
22.9-24.9	27	125	200	40	40	No	VA4D2724N	\$1,742
[10.8" (275 mm) pole spacing]			600			No	VA4D2764N	\$1,932
			1200			No	VA4D2714N	\$2,352
34.5	38	150	600	40	30	No	VA6E3864N	\$3,667
[14.1" (360 mm) pole spacing]			800			No	VA6E3884N	\$3,820

Smart style codes for UL recognized designs have "U" in the 9th digit position. Smart style codes for non-UL designs end with "N."

Electrical control options

Shunt trip / auxiliary switches

Shunt trip

The shunt trip option is available for local push button or remote switching applications. The shunt trip can be installed only on VersaRupters with stored energy (A-mechanism) mechanisms. The shunt trip utilizes a solenoid to actuate the A-mechanism trip latch. An auxiliary switch is required with shunt trip option. Shunt trip coils are intermittent duty coils. A VersaRupter switch-operated auxiliary contact must be in series with the trip coil so that power is removed from the coil after VersaRupter change-of state. See Table 3 for auxiliary switch selection.

Table 2: Shunt Trip Device

Control Voltage	Catalog Number	Digit Position 10	List Price (USD)
No Shunt Trip		0	
24 VDC	186-873-006	1	\$192
48 VDC	186-873-005	2	\$184
110 VDC	186-873-004	3	\$166
220 VDC	186-873-003	4	\$175
110 VAC	186-873-002	5	\$166
220 VAC	183-873-001	6	\$175

Price includes shunt trip device, mounting brackets and hardware.

Auxiliary switches

VersaRupter switches do not include any auxiliary contacts unless specified as an option from Table 3. The auxiliary switch contacts change state when the VersaRupter contacts change state. The auxiliary switch can be installed on all VersaRupter switches and all grounding switches. Auxiliary switches are shipped with an equal number of normally open and normally closed contacts, which may be reconfigured in the field as needed. An optional fuse auxiliary switch is available to indicate an open fuse condition. This switch has two contacts, one normally open and one normally closed, and is actuated by the tie rod linkage connected to the Type CEF fuse base.

Table 3: Auxiliary Switches

Description	Catalog Number		Digit Position 11	List Price (USD)
	5 - 27 kV	38 kV		
No Auxiliary Contacts			0	\$0
6 Contact Switch	244-006-516		5	\$219
		244-006-514	6	\$229
8 Contact Switch	244-006-515		7	\$292
		244-006-517	8	\$306
Open Fuse Aux. Switch	244-006-518		9	\$184

Price includes auxiliary switch, linkage, and mounting bracket

1 Shunt trip installed | 2 Shunt trip | 3 Aux switch | 4 Aux switch installed | 5 Open fuse aux switch | 6 Open fuse aux switch installed

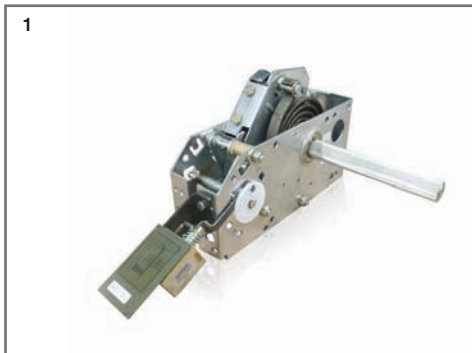

Operating Handles Selection Guide

The VersaRupter switch can be operated with a variety of handles as well as a motor operator. Operators may be mounted in a variety of positions and offer various features. Some operators are not compatible with all mechanisms and features. The chart below provides compatibility guidance.

Selection Guide - Operators vs Feature Compatibility							
Handle Operator	Location	Use with K-mech	Use with A-mech	Mechanical Door Interlock	Key Interlock	Shunt Trip	Motor Operator ¹
Chain drive without Door Interlock (see Table 4)	Front mounted with left or right side drive	X			X		
Chain drive with Door Interlock (see Table 5)	Front mounted with left or right side drive	X		X			
Direct Drive (see Table 6)	Shaft mounted with left or right side drive	X			X		
Manual Shaft Drive Type HE ² See table 7)	Front mounted with right or left side drive	X	X			X	
	Manual with NM motor	X	X			X	X

¹ If manual operator is required in conjunction with NM motor operator, a type HM shaft drive with removable handle should be selected

² The HE operator does not provide for key interlocking. However it does have provisions for padlocking the handle spline, which prohibits installation of the removable handle

Handle Options with Type K Snap Action Mechanism		
Handle Operator	Front mounted chain drive handle without mechanical door interlock	Right side mounting
		Left side mounting
	Front mounted chain drive handle with mechanical door interlock	Right side mounting
		Left side mounting
	Direct drive handle	Right side mounting
		Left side mounting
	HE shaft operator	Right side mounting
		Left side mounting

Handle Options with Type A Stored Energy Mechanism		
Handle Operator	HE Shaft Operator	Right side mounting
		Left side mounting
	HM Shaft Operator (use with NM motor)	Right side mounting
		Left side mounting
		Right side mounting
		Left side mounting

Operating handles (continued)

Chain drive handles without door interlock

The following chain drive handles are for use with K-mechanism snap action switches that do not require a door interlock.

Front-mounted right side chain drive handles are for attachment directly to the type K-mechanism on the right side of the VersaRupter. The “spreader bar” spans the distance from the front door flange where the handle is located to the center-line of the switch shaft, maintaining tension on the drive chain.

Front-mounted left side chain drive handles connect to the VersaRupter using a left hand shaft extension. These handles do not utilize a spreader bar. Left side catalog numbers below include all the chain drive handle parts, plus the left hand shaft extension. Select left side chain drive handles in accordance with the voltage rating of the VersaRupters from Table 1A so that the proper left hand shaft extension will be provided with this handle.

Chain drive handles have provisions for two key interlocks and can handle three interlock schemes including lock open only, lock closed only, and lock open only/lock closed only. Key interlock systems will function on left and right hand mounted chain drive handles. A type F Kirk Key interlock with a 2” lock bolt should be specified for the key to be withdrawn in the extended position (KFL020010E). This ensures that possession of the key indicates the switch is locked in the desired scheme. Two 3/8”-16 x 1-3/4” bolts are required per key interlock for mounting. Information to achieve desired schemes is available in drawing 321-105 per request. Interlocks must be ordered from Kirk Key interlock.

Table 4: Chain Drive Handles without Door Interlock

Description	Catalog Number	Digit Position 12-15	List Price (USD)
Right Side Options			
Front mounted, right side operation, spreader bar: 29.625” to 34”	244-037-510	CCR1	\$289
front mounted, right side operation, spreader bar: 34.625” to 39.0”	244-037-511	CCR2	\$304
Front mounted, right side operation, spreader bar: 39.625” to 44.0”	244-037-512	CCR3	\$338
Front mounted, right side operation, spreader bar: 61.625” to 66.0”	244-037-514	CCR4	\$386
Left Side Options			
Front mounted, left side operation for 8.25 kV switch (5.9” pole spacing)	244-037-501	CCLA	\$295
Front mounted, left side operation for 15.0 kV switch (6.69” pole spacing)	244-037-502	CCLB	\$366
Front mounted, let side operation for 15.0-17.0 kV switch (9.25” pole spacing)	244-037-503	CCLC	\$403
Front mounted, left side operation for 27.0 kV switch (10.8” pole spacing)	244-037-504	CCLD	\$412
Front mounted, left side operation for 38.0 kV switch (14.1” pole spacing)	244-037-505	CCL E	\$471

1 Spreader bar and chain | 2 Kirk Key right | 3 Kirk Key left



Chain drive handles with mechanical door interlock

The following chain drive handles are for both right and left side operation, utilizing a mechanical door interlock. They automatically latch the switchgear door when the VersaRupter is closed. Each assembly includes all parts required to actuate the VersaRupter switch, while interlocking the switchgear door. The mechanical door interlock is pre-installed on the chain drive handle assembly and includes the catch plate that fastens to the door to be automatically latched. Two styles are offered: standard and offset. Standard doors close against the front of the switchgear frame and project forward from the switchgear frame a dimension equal to the door depth. Offset doors are those that close into a recess in the switchgear frame so that the door is flush with the switchgear front when closed. Select the chain drive handle assembly according to the type of door used. Right hand chain drive handles include a spreader bar of various lengths from which to select. Left hand chain drive handles include the left hand shaft extension sized to the voltage rating of the switch.

Do not use these handles with type A-mechanism stored energy mechanisms.



Mechanical door interlock assembly



Chain drive handle installed on switchgear

Table 5: Chain Drive Handles with Mechanical Door Interlock

Description	Door Type	Catalog Number	Digit Position 12-15	List Price (USD)
Right Side Options				
Front mounted, right side operation, spreader bar: 29.625" to 34.0"	Standard	244-037-517	CDR1	\$543
	Offset	244-037-521	CFR1	\$557
Front mounted, right side operation, spreader bar: 34.625" to 39.0"	Standard	244-037-518	CDR2	\$558
	Offset	244-037-522	CFR2	\$572
Front mounted, right side operation, spreader bar: 39.625" to 44.0"	Standard	244-037-519	CDR3	\$592
	Offset	244-037-523	CFR3	\$606
Front mounted, right side operation, spreader bar: 61.625" to 66.0"	Standard	244-037-520	CDR4	\$640
	Offset	244-037-524	CFR4	\$654
Left Side Options				
Front mounted, left side operation, for 8.25 kV switch (5.9" pole spacing)	Standard	244-037-525	CDLA	\$598
	Offset	244-037-530	CFLA	\$612
Front mounted, left side operation, for 15.0 kV switch (6.69" pole spacing)	Standard	244-037-526	CDLB	\$620
	Offset	244-037-531	CFLB	\$634
Front mounted, left side operation, for 15.0-17.0 kV switch (9.25" pole spacing)	Standard	244-037-527	CDLC	\$623
	Offset	244-037-532	CFLC	\$637
Front mounted, left side operation, for 27.0 kV switch (10.8" pole spacing)	Standard	244-037-528	CDLD	\$666
	Offset	244-037-533	CFLD	\$680
Front mounted, left side operation, for 38.0 kV switch (14.1" pole spacing)	Standard	244-037-529	CDLE	\$725
	Offset	244-037-534	CFL E	\$739

Operating handles (continued)

Direct drive handle / type HE shaft drive operator

Direct drive handle

A manual operator handle is available for shaft-mounted direct operation of the VersaRupter from either side of the switchgear cabinet. The handles are available for fixed-mount applications. The left side handle includes the appropriate left-hand shaft extension kit. Padlocking is available with the fixed mount handle.

Direct drive handles have provisions for two key interlocks and can handle two interlock systems including lock open only and lock open/lock closed. Key interlock systems will function on left and right hand mounted direct drive handles. A type B Kirk Key interlock with a 3/8" lock bolt should be specified for the key to be withdrawn in the extended position (KBL003710E). This ensures that possession of the key indicates the switch is locked in the desired scheme. Two 3/8"-16 x 3/4" bolts are required per key interlock for mounting. Information to achieve desired schemes is available in drawing S-20138 per request.

Type HE/HM shaft drive operator

The "HE" operator provides front-mounted direct drive connection to the switch main shaft. A bevel gear is provided for connection to the switch shaft, and a universal joint linkage is provided at the handle. These components accept a 0.75 inch galvanized pipe (not provided) which allows the VersaRupter to be positioned up to five feet from the front of the enclosure (special 1 inch fittings are required for greater distances). The type HE operator is available in a locking coupled style for manual operation, and a de-coupled style for motor operation. Neither a mechanical door interlock nor key interlock provisions are available for the HE operators. However, the handle spline may be padlocked to prohibit installation of the removable handle.

Table 6: Direct Drive Operating Handles (side-mounted)

Description	Catalog Number	Digit Position 12-15	List Price (USD)
Side mounted, right side operation for switches of all voltage ratings	244-063-501	DDRR	\$114
Side mounted, left side operation for 8.25 kV switches (5.9" pole spacing)	244-063-505	DDLA	\$183
Side mounted, left side operation for 15.0 kV switches (6.69" pole spacing)	244-063-506	DDLB	\$190
Side mounted, left side operation for 15.0-17.0 kV switches (9.25" pole spacing)	244-063-507	DDLK	\$195
Side mounted, left side operation for 27.0 kV switches (10.8" pole spacing)	244-063-508	DDLJ	\$206
Side mounted, left side operation for 38.0 kV switches (14.1" pole spacing)	244-063-509	DDLE	\$220

Table 7: Type HE Shaft Drive (front-mounted)

Description	Catalog Number	Digit Position 12-13	List Price (USD) with handle
Manual	186-023-301	HE	\$227
Manual for use with type NM motor operator	186-023-304	HM	\$242
Removable handle	183-786-001	Included	\$52

1 Direct Drive Handle | 2 Direct Drive Close Up | 3 Max shaft angle for HE installation | 4 Bevel gear | 5 HE | 6 Removable handle | 7 HM

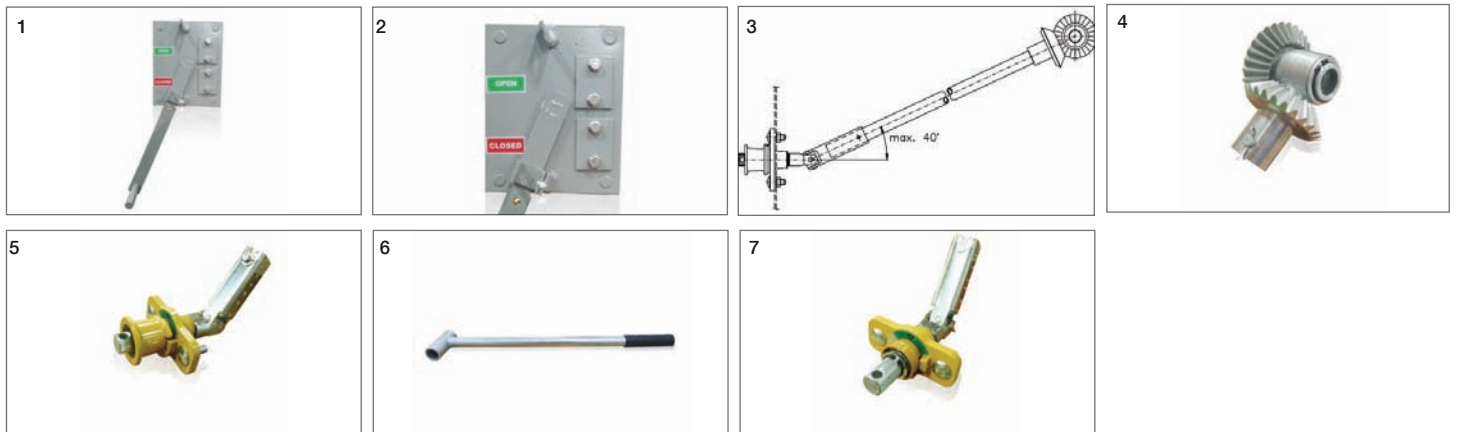

Motor operator option

Type NM



NM motor operator



Motor controller

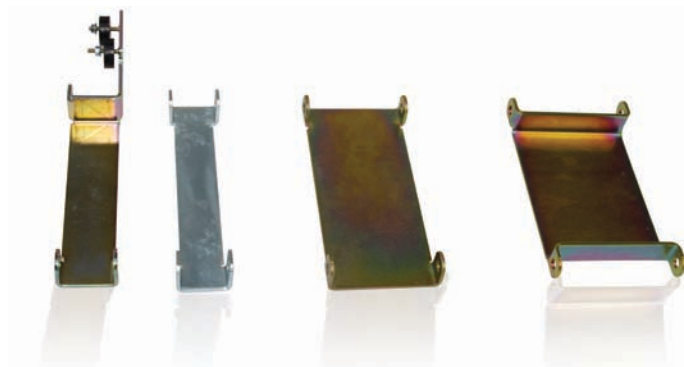

Spacer brackets

Note: Spacer brackets must be ordered separately.

The compact lightweight NM motor operator provides for remote electrical opening and closing of the VersaRupter. The NM motor operator is installed on the splined shaft of the VersaRupter mechanism (either K-mechanism or A-mechanism) or on a left-hand shaft extension. A spacer bracket must be ordered separately. The spacer bracket for the A-mechanism allows for proper installation of the open fuse aux switch.

Table 8: Type NM Motor Operator

Control Voltage	Catalog Number	Digit Position 16-18	List Price (USD)
Mounted on right side of switch splined shaft (includes motor controller board) - spacer bracket must be ordered separately			
24 VAC or VDC	245-869-001	1RR	\$2,736
48 VAC or VDC	245-869-002	2RR	\$2,682
110 VAC or VDC	245-869-003	3RR	\$2,614
220 VAC or VDC	245-869-004	4RR	\$2,722
Mounted on left side of switch (includes left hand shaft extension and motor controller board) - spacer bracket must be ordered separately			
24 VAC or VDC	5.9" pole spacing	1LA	\$2,805
	6.69" pole spacing	1LB	\$2,812
	9.25" pole spacing	1LC	\$2,817
	10.8" pole spacing	1LD	\$2,828
	14.1" pole spacing	1LE	\$2,842
48 VAC or VDC	5.9" pole spacing	2LA	\$2,751
	6.69" pole spacing	2LB	\$2,758
	9.25" pole spacing	2LC	\$2,763
	10.8" pole spacing	2LD	\$2,774
	14.1" pole spacing	2LE	\$2,788
110 VAC or VDC	5.9" pole spacing	3LA	\$2,683
	6.69" pole spacing	3LB	\$2,690
	9.25" pole spacing	3LC	\$2,695
	10.8" pole spacing	3LD	\$2,706
	14.1" pole spacing	3LE	\$2,720
220 VAC or VDC	5.9" pole spacing	4LA	\$2,791
	6.69" pole spacing	4LB	\$2,798
	9.25" pole spacing	4LC	\$2,803
	10.8" pole spacing	4LD	\$2,814
	14.1" pole spacing	4LE	\$2,828

Part numbers for brackets (Brackets required for either right or left hand operation with NM motor.)

Spring mechanism type K

VersaRupter	8.25		15		15.5		17		27		38		List Price
	L	R	L	R	L	R	L	R	L	R	L	R	
Mounting side													
Part Number	Description												
245-870-011		X		X		X		X		X		X	\$24
245-870-012	X		X		X		X						\$28
245-870-013													\$36
245-870-014									X			X	\$46

Spring mechanism type A

VersaRupter	8.25		15		15.5		17		27		38		List Price
	L	R	L	R	L	R	L	R	L	R	L	R	
Mounting side													
Part Number	Description												
245-870-015		X		X		X		X		X		X	\$72

Optional accessories (to be ordered separately)

Grounding switches type E

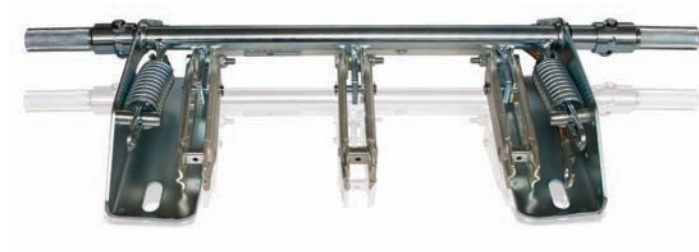

Type E grounding switch



Removable handle



Mechanical interlock

Grounding switches are available for connection to the lower terminals of the VersaRupter or the VersaRupter fuse base. If removable operating handle, P/N # 183-786-001 is not part of VersaRupter switch, then quantity 1 must be ordered for earthing switch. An HE handle may also be used to operate earthing switch.

Note: It is required that mechanical interlocks be used in conjunction with ground switches. Interlocks prevent closing of the VersaRupter when the ground switch is closed. Please select an appropriate interlock from one of the lower sections in table 9.

The mechanical interlock prevents the VersaRupter from being closed when the Type E grounding switch is closed. Mechanical interlocks are available in various lengths to accommodate grounding switches mounted on the hinged side of the VersaRupter or at the bottom of the fuse base.

Note: Mechanical interlocking is mounted on the left hand side and requires a left hand shaft extension for the VersaRupter (see Table A2).

Table 9: Grounding Switches for Connection to VersaRupter Lower Terminal (40 kA switches only)

System Rating (kV)	Nominal Rated Current (A)	Catalog Number	List Price (USD)
Ground Switches for Connection to VersaRupter Lower Terminal			
4.6 - 7.2	200, 600	323-026-010	\$398
[5.9" (150 mm) pole spacing]	1200	323-026-001	\$486
12.0 - 13.8	200, 600	323-026-012	\$426
6.69" (170 mm) pole spacing]	1200	323-026-003	\$512
12.0 - 16.5	200, 600	323-026-013	\$448
[9.25" (235 mm) pole spacing]	1200	323-026-004	\$526
22.9 - 24.9	200, 600	323-026-014	\$472
[10.82" (275 mm) pole spacing]	1200	323-026-005	\$554
34.5	600, 800	323-026-025	\$2,448
[14.17" (360 mm) pole spacing]			
Ground Switches for Connection to VersaRupter Fuse Base			
4.6 - 7.2	200, 600	323-026-015	Consult Factory
[5.9" (150 mm) pole spacing]	1200	323-026-020	Consult Factory
12.0 - 13.8	200, 600	323-026-017	Consult Factory
6.69" (170 mm) pole spacing]	1200	323-026-022	Consult Factory
12.0 - 16.5	200, 600	323-026-018	Consult Factory
[9.25" (235 mm) pole spacing]	1200	323-026-023	Consult Factory

**Table 9: Grounding Switches for Connection to VersaRupter
Lower Terminal (40 kA switches only)**

System Rating (kV)	Nominal Rated Current (A)	Catalog Number	List Price (USD)
Ground Switches for Connection to VersaRupter Fuse Base			
22.9 - 24.9 [10.82" (275 mm) pole spacing]	200, 600 1200	323-026-019 323-026-024	Consult Factory Consult Factory
34.5 [14.17" (360 mm) pole spacing]	600, 800	323-026-025	Consult Factory
Mechanical Interlocks for VersaRupter w/o Fuse Base (40 kA VersaRupter only)			
4.6 - 7.2 [5.9" (150 mm) pole spacing]	200-1200	186-856-001	\$54
12.0 - 13.8 6.69" (170 mm) pole spacing]	200-1200	186-856-002	\$64
12.0 - 16.5 [9.25" (235 mm) pole spacing]	200-1200	186-856-002	\$72
22.9 - 24.9 [10.82" (275 mm) pole spacing]	200-1200	186-856-002	\$84
34.5 [14.17" (360 mm) pole spacing]	600-800	186-856-010	\$122
Mechanical Interlocks for VersaRupter with Fuse Base (40 kA VersaRupter only)			
System Rating (kV)	CEF Fuse Length (inches)	Catalog Number	List Price (USD)
4.6 - 7.2 [5.9" (150 mm) pole spacing]	7.5 11.5 17.4	186-856-004 186-856-003 186-856-005	Consult Factory Consult Factory Consult Factory
12.0 - 13.8 6.69" (170 mm) pole spacing]	11.5	186-856-006	Consult Factory
12.0 - 16.5 [9.25" (235 mm) pole spacing]	17.4	186-856-007	Consult Factory
22.9 - 24.9 [10.82" (275 mm) pole spacing]	17.4 21.1	186-856-008 186-856-009	Consult Factory Consult Factory
34.5 [14.17" (360 mm) pole spacing]	21.1	186-856-012	Consult Factory

Fuse options

Fuse bases

Fuse bases are offered for mounting type CEF fuses, with or without fuse tripping, on the upper or lower terminals of the VersaRupter switch. Use the fuse bases with fuse tripping only with the latching stored energy mechanism (A-mechanism) found on the switches in Table 1B. Fuse bases in Tables 10-13 use CEF fuses, only. Order fuses from Table 14. Contact the factory for availability of fuse bases, fuse base options or part identification for 61 kA switches. (Prices include fuse clamps.)

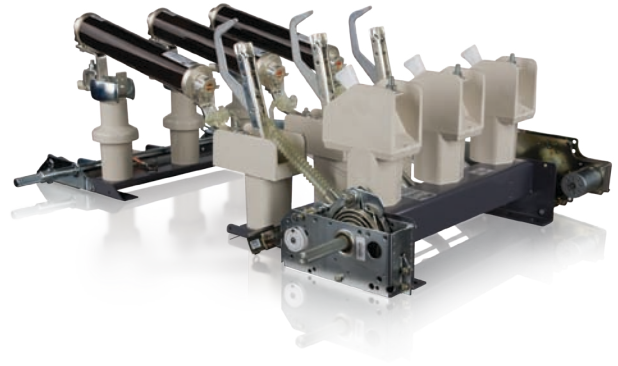

Accessory: Open fuse AUX switch (244-006-518)

Note: Fuse base not available for 1200A switches.

Table 10: Bottom Mounted Fuse Base without Fuse Tripping - (Use with type CEF Fuses only)

System Rating (kV, nominal)	Pole Spacing (in/mm)	Rated Current (A)	Catalog Number	List Price (USD)
4.6 - 7.2	5.9 / 150	200	186-900-001	Consult Factory
12.0 - 13.8	6.69 / 170	200	186-900-003	Consult Factory
12.0 - 16.5	9.25 / 235	200	186-900-004	Consult Factory
22.9 - 24.9	10.82 / 275	200	186-900-005	Consult Factory
34.5	14.17 / 360	200	186-900-006	Consult Factory

Table 11: Top Mounted Fuse Base without Fuse Tripping - (Use with type CEF Fuses only)

System Rating (kV, nominal)	Pole Spacing (in/mm)	Rated Current (A)	Catalog Number	List Price (USD)
4.6 - 7.2	5.9 / 150	200	186-900-007	Consult Factory
12.0 - 13.8	6.69 / 170	200	186-900-009	Consult Factory
12.0 - 16.5	9.25 / 235	200	186-900-010	Consult Factory
22.9 - 24.9	10.82 / 275	200	186-900-011	Consult Factory
34.5	14.17 / 360	200	186-900-012	Consult Factory

Table 12: Bottom Mounted Fuse Base with Fuse Tripping - (Use with type CEF Fuses only)

System Rating (kV, nominal)	Pole Spacing (in/mm)	Rated Current (A)	Catalog Number	List Price (USD)
4.6 - 7.2	5.9 / 150	200	186-899-001	Consult Factory
12.0 - 13.8	6.69 / 170	200	186-899-003	Consult Factory
12.0 - 16.5	9.25 / 235	200	186-899-004	Consult Factory
22.9 - 24.9	10.82 / 275	200	186-899-005	Consult Factory
34.5	14.17 / 360	200	186-899-006	Consult Factory

Table 13: Top Mounted Fuse Base with Fuse Tripping - (Use with type CEF Fuses only)

System Rating (kV, nominal)	Pole Spacing (in/mm)	Rated Current (A)	Catalog Number	List Price (USD)
4.6 - 7.2	5.9 / 150	200	186-899-007	Consult Factory
12.0 - 13.8	6.69 / 170	200	186-899-009	Consult Factory
12.0 - 16.5	9.25 / 235	200	186-899-010	Consult Factory
22.9 - 24.9	10.82 / 275	200	186-899-011	Consult Factory

Fuse options (continued)

Type CEF Fuses

Table 14: Type CEF Fuses

Rating Voltage (kV)	Rated Current (A)	Fuse Dimensions Length/Diameter (inches)	Catalog Number	List Price (USD)	
3.6 / 7.2	6	7.55 / 2.55	186-904-048	Consult Factory	
	10		186-904-049	Consult Factory	
	16		186-904-050	Consult Factory	
	25		186-904-051	Consult Factory	
	40		186-904-052	Consult Factory	
	50		186-904-053	Consult Factory	
	63	7.55 / 3.4	186-904-054	Consult Factory	
	80		186-904-055	Consult Factory	
	100		186-904-056	Consult Factory	
	125		11.5 / 3.4	186-904-057	Consult Factory
	160			186-904-058	Consult Factory
	200			186-904-059	Consult Factory
12	6	11.5 / 2.55	186-904-001	Consult Factory	
	10		186-904-002	Consult Factory	
	16		186-904-003	Consult Factory	
	25		186-904-004	Consult Factory	
	40		186-904-005	Consult Factory	
	50		186-904-006	Consult Factory	
	63	11.5 / 3.4	186-904-007	Consult Factory	
	80		186-904-008	Consult Factory	
	100		186-904-009	Consult Factory	
	125		17.4 / 3.4	186-904-010	Consult Factory
	160			186-904-011	Consult Factory
	200			186-904-012	Consult Factory
17.5	6	11.5 / 2.55	186-904-013	Consult Factory	
	10		186-904-014	Consult Factory	
	16		186-904-015	Consult Factory	
	25		186-904-016	Consult Factory	
	40		186-904-017	Consult Factory	
	50		186-904-018	Consult Factory	
	63	11.5 / 3.4	186-904-019	Consult Factory	
	80		186-904-020	Consult Factory	
	100		17.4 / 3.4	186-904-021	Consult Factory
	125		17.4 / 2.55	186-904-022	Consult Factory
				186-904-023	Consult Factory
				186-904-024	Consult Factory
	186-904-025	Consult Factory			
24	6	17.4 / 2.55	186-904-026	Consult Factory	
	10		186-904-027	Consult Factory	
	16		186-904-028	Consult Factory	
	25		17.4 / 3.4	186-904-029	Consult Factory
	40			186-904-030	Consult Factory
	50			186-904-031	Consult Factory
	63	21.1 / 3.4		186-904-032	Consult Factory
	80		186-904-033	Consult Factory	
	80				
	100				
	125				

Fuse options (continued)

Type CEF Fuses

Table 14: Type CEF Fuses

Rating Voltage (kV)	Rated Current (A)	Fuse Dimensions Length/Diameter (inches)	Catalog Number	List Price (USD)
27	6	17.4 / 2.55	186-904-034	Consult Factory
	10		186-904-035	Consult Factory
	16		186-904-036	Consult Factory
	25	17.4 / 3.4	186-904-037	Consult Factory
	40		186-904-038	Consult Factory
	50		186-904-039	Consult Factory
	63		186-904-040	Consult Factory
	80	21.1 / 3.4	186-904-041	Consult Factory
	100		186-904-042	Consult Factory
	36	6	21.1 / 2.55	186-904-043
10			186-904-044	Consult Factory
16			186-904-045	Consult Factory
25		21.1 / 3.4	186-904-046	Consult Factory
40			186-904-047	Consult Factory

Use with fuse bases in Tables 10-13. Consult the factory for CMF style fuses, which may be used in fuse bases in Tables 10-13 for medium voltage motor applications.

Miscellaneous accessories

Back connection kit / shaft extensions / splined tubes

Back connection kits

Back connect kits are available for positioning the line and load connections of the VersaRupter to the rear for dead front applications.

Note: Contact factory for pricing



Left Side Shaft Extensions

200 - 600 (A)	Configuration	Momentary Rating (kA)	Catalog Number
5 kV	Upper & Lower	40	245-901-501
	Lower only		245-901-502
	Upper only		245-901-503
15 kV	Upper & Lower	40	245-902-501
	Lower only		245-902-502
	Upper only		245-902-503
17 kV	Upper & Lower	40	245-903-501
	Lower only		245-903-502
	Upper only		245-903-503
27 kV	Upper & Lower	40	245-904-501
	Lower only		245-904-502
	Upper only		245-904-503
15 & 15.5 kV	Upper & Lower	61	245-906-501
	Lower only		245-906-502
	Upper only		245-906-503

Left side shaft extensions

Optional shaft extensions are available for left-hand operation using motor operators or manual operator handles. Some shaft extensions may be grooved for cutoff to the precise extension required. Catalog numbers include shaft mounting hardware. Pole spacing for extensions must match that of switch to be installed onto.

Table A2: Handle Accessories

Description	Catalog Number	List Price (USD)
8.25 kV switch, 5.9" (150 mm) pole spacing	244-044-501	\$69
15.0 kV switch, 6.69" (170 mm) pole spacing	244-044-502	\$76
17.0 kV switch, 9.25" (235 mm) pole spacing	244-044-504	\$81
27.0 kV switch, 10.8" (275 mm) pole spacing	244-044-505	\$92
38.0 kV switch, 14.1" (360 mm) pole spacing	244-044-506	\$106



Joint Link



Splined Tube

Right side shaft extensions

Optional shaft extensions are available for right-hand operation. To order, select the desired shaft extension and then select the joint link.

Description	Catalog Number	List Price (USD)
Right side shaft extension, 14.96" (380 mm)	1YMX053349M0001	\$32
Right side shaft extension, 18.50" (470 mm)	1YMX053348M0001	\$54
Joint link for right side shaft extension	1YMX053350M0001	\$28

Splined tube

Optional splined tube provides the ability to create shaft extensions, customize operator handles or link the mechanical actuation of the switch together.

Type	Catalog Number	Length (inches)	List Price (USD)
Splined tube (1.125")	186-851-001	1.125	\$14
Splined tube (2.880")	186-083-003	2.880	\$29

Notes

Notes

Notes

Contact us

ABB Inc.

655 Century Point

Lake Mary, FL 32746

Phone: +1 407 732 2000

Customer service: +1 800 929 7947 ext. 5

+1 407 732 2000 ext. 2510

E-Mail: customer.service.group@us.abb.com

www.abb.com/mediumvoltage

All sales are subject to ABB Inc.
General Terms and Conditions of Sale.

While every effort has been made to assure accuracy, the
information in this document is subject to change without
notice.

© Copyright 2011 ABB Inc. All rights reserved.