



IEC 61850 in ZX Gas-insulated medium voltage switchgear

IEC 61850 in ZX

Gas-insulated medium voltage switchgear

Just as the supply of electrical power is becoming more and more important in a networked world, demands for the integration of electrical switchgear in network-level monitoring and control systems are constantly growing.

If a smooth bidirectional flow of information is to take place, it is necessary for components to understand each other, even if they come from different manufacturers. The global communications standard IEC 61850 was developed for just that purpose.

It is based on predecessors from the IEC and ANSI worlds, and enables greater compatibility and functionality than all previous standards.

Modern gas-insulated medium voltage switchgear has maintenance-free high voltage technology, plug-in connections requiring no gas work and monitorized operating mechanisms for remote control. It is thus a matter of course for communication within the switchgear installation and to higher level automation systems to be of the same high quality.

The basis of this is communication, both between devices within the switchgear system and ranging upwards to the power network facilities.

Devices of various types and devices from different manufacturers must all understand each other.

Features of IEC 61850:

- Ethernet communication on substation level
- Consistent object-oriented data model
- Covers all aspects of substation automation such as protection **and** control functions
- Real-time GOOSE messages (GOOSE stands for **Generic Object Oriented Substation Events**, i.e. typical events in switchgear systems), for instance for the exchange of information on switch positions directly between field devices in the ZX panels, for interlock purposes or protection events.

Your benefit form IEC 61850:

- A standard applicable worldwide for all areas of substation automation
- Interoperability of devices, irrespective of manufacturer
- Standardization and simplification
- Avoidance of multiple protocols and problems with interfaces by consistent use of Ethernet technology
- Savings throughout the service life of ZX systems: from project planning to servicing

GOOSE messages:

GOOSE messages facilitate direct communication between field devices in a ZX switchgear system, enabling them to exchange information via the substation bus on, for example, switch positions or inter-panel interlock configurations, or to implement protection commands such as those for circuit-breaker failure protection.

GOOSE messages are time-critical and have priority over other information transmitted through the bus. For this reason, reliable and deterministic use of GOOSE can only be ensured by devices which have been developed to the IEC 61850 standard and make that communication standard available consistently from the field device upwards, without time-consuming internal or external protocol conversions. The Relion® product family for protection and control makes a range of such devices developed specifically for IEC 61850 available, fulfilling precisely these requirements for modern substation communications.

This product family is used throughout the ZX portfolio, from the smallest ZX0 in block design through ZX1.2 single busbar systems to ZX2 double busbar systems for 40 kA at 36 (42) kV.

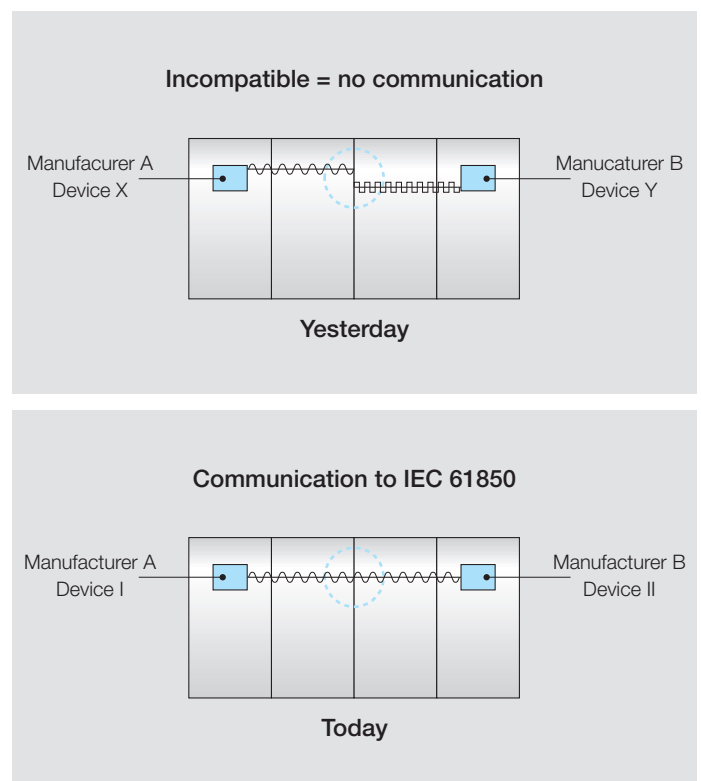

Tools for IEC 61850

Just as important as field devices with complete IEC 61850 capability are the corresponding tools for device programming, substation engineering and monitoring of Ethernet communications.

The PCM600 configuration tool was developed both for programming of individual protection devices and for engineering of entire substations with several voltage levels. Depending on the type of field device, configuration is effected via a signal matrix or a graphical user interface.

Comparison of a local device configuration with the version on the commissioning engineer's computer is facilitated by clear display of the deviations. Visualization of disturbance recordings is provided, together with a host or other functions.

With the use of GOOSE messages for panel to panel communications, information, for example on switch positions, is no longer available as a binary signal at a loop line terminal strip in the switchgear installation as in systems with conventional communications, but only as a data package on the substation bus which cannot be checked using classical measuring methods. The ITT600 system analysis tool is available to make this information visible.

ITT600 permits scanning of all the IEC 61850 devices in the network and also provides for the monitoring of all GOOSE messages between the individual devices using a special GOOSE Explorer. It is an indispensable tool, especially during commissioning and for troubleshooting.

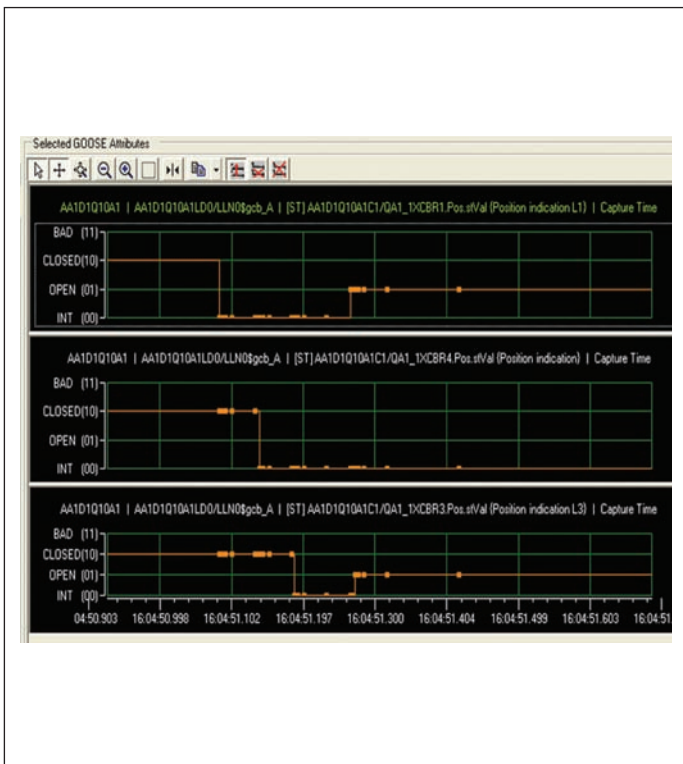

Graphical display of GOOSE information on a service PC

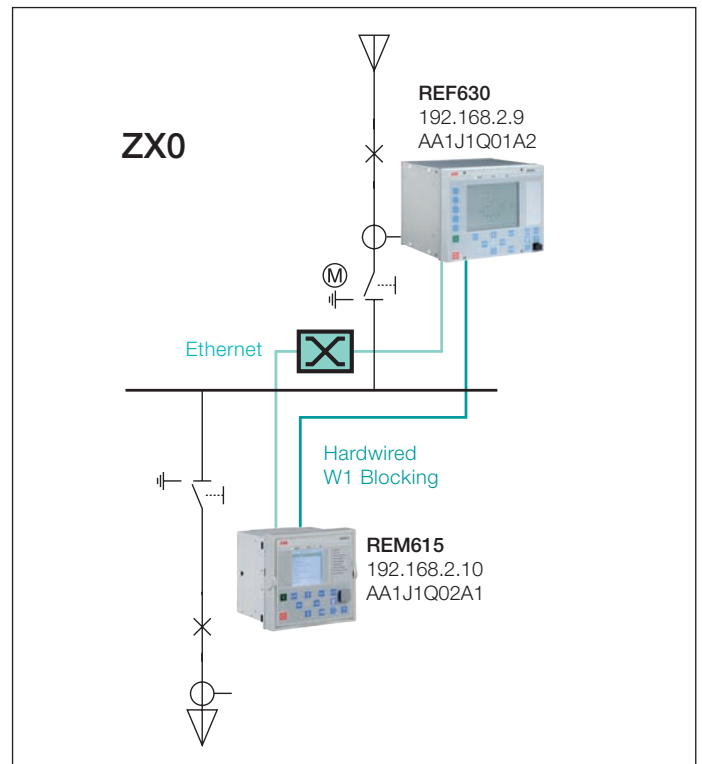

Test set-up: Blocking of protection functions, circuit-breaker failure protection, rear interlock and interruption of communication

Superior data transmission with GOOSE messaging

On behalf of ABB AG, KEMA tested the performance of GOOSE communications in comparison with direct signal transmission between two devices through conventional wiring. The test programme was based on IEC 62271-3 and was performed with gas-insulated switchgear of type ZX and the REM615 and REF630 protection devices from the Relion® product range.

The results of the KEMA test at a glance:

- Data transmission with GOOSE is between 12 ms and 15 ms faster than with conventional wiring.
- In the event of an interruption to GOOSE communication, the system reacts as specified and blocks the set protection functions.
- Interlocks to prevent double switching operations function as specified

The Relion® devices comply with class P1, message type 1A "Trip" to IEC 61850-5 for message transmission time less than 10 ms.

Your benefits from GOOSE in ZX switchgear systems:

- Superior data transmission speed
- Less wiring and greater clarity
- Simple modification without additional wiring work
- Addition of functions to existing systems
- More inputs and outputs available at the protection devices
- Permanent monitoring of the signal/communications link
- Protection and control devices from the Relion® 615 and 630 series fulfill the highest GOOSE performance requirements to IEC 61850

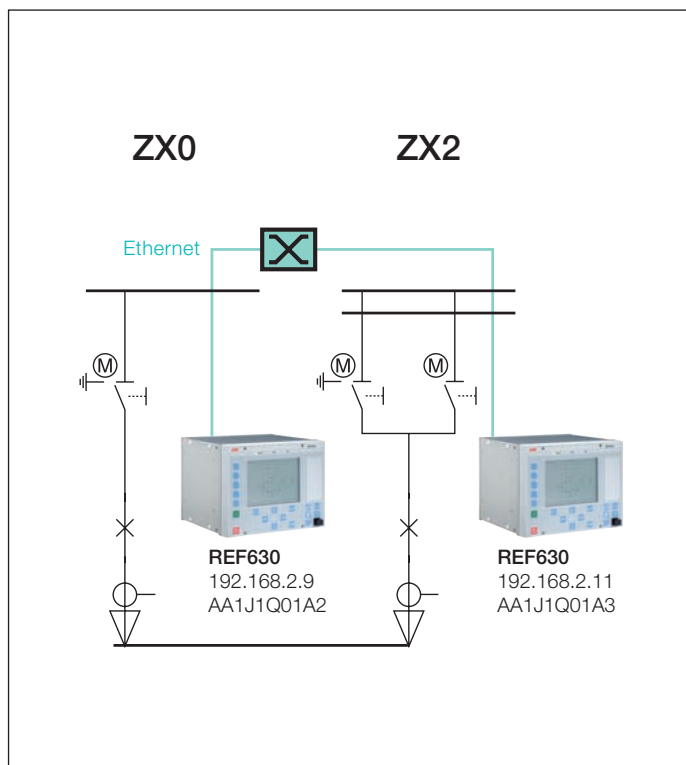

Test set-up: Blocking of double switching operations

GOOSE communication in comparison with conventional wiring



REF615



REF630

IEC 61850 compliant devices for ZX

All the devices of the Relion® product family suitable for ZX from the 615 series onwards have full IEC 61850 and GOOSE capability:

615 series

615 series devices are notable for:

- Control of a circuit-breaker directly at the device
- Practical plug-in design
- Large number of binary inputs and outputs, e.g. for position signals and interlocks
- 11 freely programmable LEDs
- Extensive measurement, monitoring and fault recorder functions
- Mimic diagram to indicate the positions of the connected switches
- Optional additional Ethernet interfaces with integrated switch

The 615 series devices are available for

- Feeder protection
- Line differential protection
- Motor protection
- Transformer differential protection
- Voltage protection

630 series

The protection and control devices of the 630 series provide the following functions:

- Control and graphical display of up to eight objects
- Installation as complete unit or with separate display
- Large number of binary inputs and outputs
- 15 freely programmable LEDs per display page (3 pages)
- Five freely programmable function keys, e.g. for macro operations or starting of automated sequences
- CT plug automatically short-circuits on withdrawable from device
- Extensive measurement, monitoring and fault recorder functions

The 630 series devices are available for

- Feeder protection including distance protection
- Motor protection
- Transformer differential protection

Contact

Your sales contact: www.abb.com/contacts
More product information: www.abb.com/productguide

Note:

We reserve the right to make technical changes or modify the contents of this document without prior notice. With regard to purchase orders, the agreed particulars shall prevail. ABB AG does not accept any responsibility whatsoever for potential errors or possible lack of information in this document.

We reserve all rights in this document and in the subject matter and illustrations contained therein. Any reproduction, disclosure to third parties or utilization of its contents – in whole or in parts – is forbidden without prior written consent of ABB AG.

Copyright© 2010 ABB
All rights reserved

ABB AG**Calor Emag Medium Voltage Products**

Oberhausener Strasse 33

40472 Ratingen, Germany

Phone: +49(0)21 02/12-0

Fax: +49(0)21 02/12-17 77

E-mail: powertech@de.abb.com

ABB AG**Calor Emag Medium Voltage Products**

Petzower Strasse 8

14542 Werder (Havel) OT Glindow, Germany

Phone: +49(0)21 02/12-0

Fax: +49(0)21 02/12-17 77

E-mail: powertech@de.abb.com

www.abb.com/mediumvoltage