

I_s-limiter

The world fastest limiting
and switching device

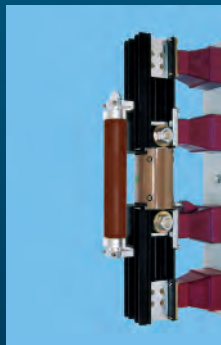
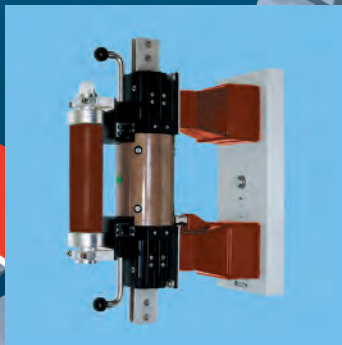
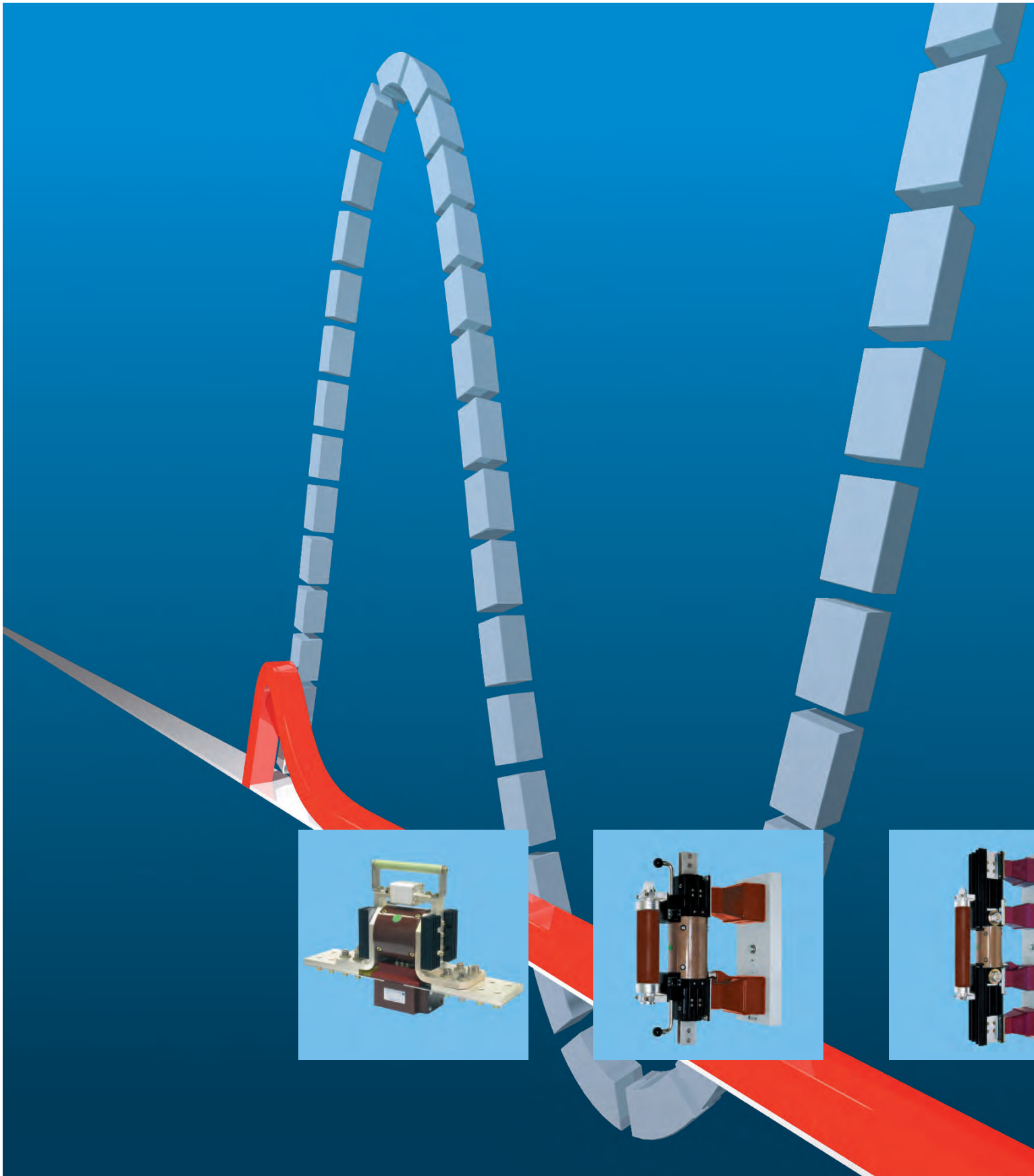

I_s -limiter

**The world's fastest
switching device**

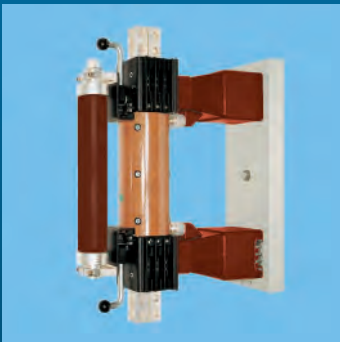
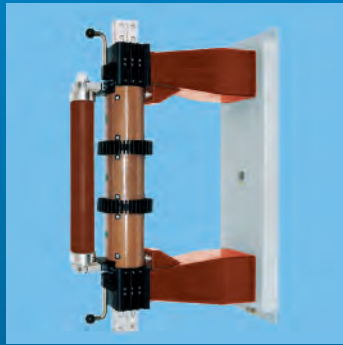

- Reduces substation cost
- Solves short-circuit problems in new substations and substation extensions
- Optimum solution for interconnection of switchboards and substations
- In most cases the only technical solution
- Reliability and function proofed in thousands of installations since 1960
- Worldwide in service
- The peak short-circuit current will never be reached
- The short-circuit current is limited at the very first current rise

Short-circuit currents too high?

The I_S -limiter, a switching device with extremely short operating time, solves the problem.

A short-circuit downstream from an outgoing feeder breaker is assumed. The oscillogram shown below indicates the course of the short-circuit currents in the first half wave.

A short-circuit current of 31.5 kA can flow to the fault location through each transformer. This would result in a total short-circuit current of 63 kA, which is twice as much as the switchgear capability.

The course of the current through the I_S -limiter in such an event is shown below as current i_2 . It can be seen that the I_S -limiter is operating so rapidly, that there is **no** contribution via the transformer T_2 to the total peak short-circuit current ($i_1 + i_2$). Therefore, a switchgear with a rating of 31.5 kA is suitable for this application.

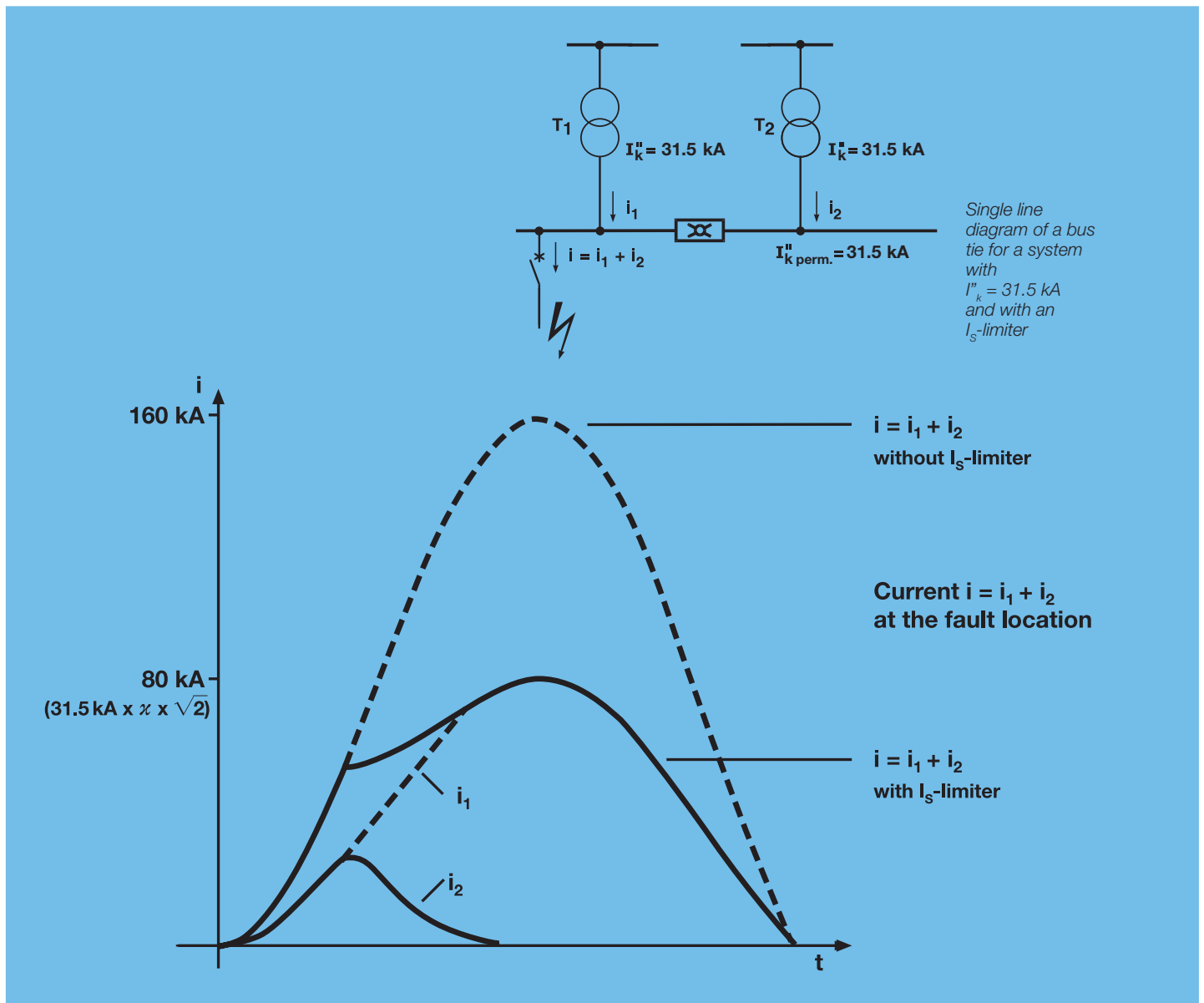

Current $i = i_1 + i_2$ at the fault location

Questions and answers regarding the I_s -limiter

1. What is the peak short-circuit current?

The peak short-circuit current i_{peak} is the maximum instantaneous value of the current after the short-circuit occurs.

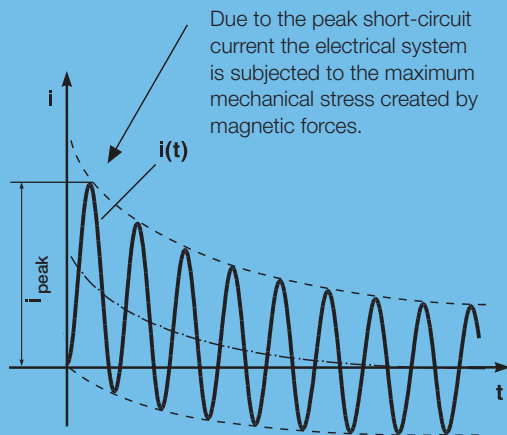

Due to the AC short-circuit current duration the system is subjected to thermal stress.

3. How can switchboards which are only dimensioned for $2 \times I_K$ be operated with four transformers infeeds and a total short-circuit current of $4 \times I_K$ without any risk of overload and without losses?

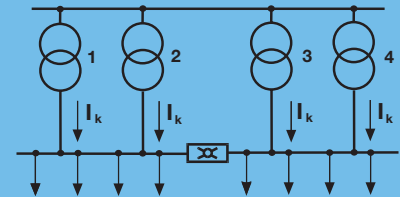

By installing an I_s -limiter between the busbar sections 1 - 2 and 3 - 4. (This is only one of the many possibilities for the use of an I_s -limiter (see page 18 for further examples).

2. Why the peak short-circuit current has to be limited?

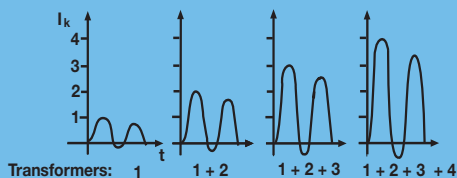
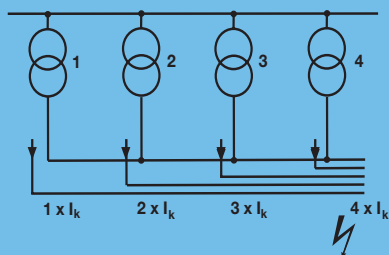

Because otherwise insufficiently dimensioned switchboards, switches, current transformers, cables, etc. would be destroyed due to the magnetic forces caused by the current.

4. How does the I_s -limiter work?

The I_s -limiter consists of two parallel conductors. The main conductor carries the high rated normal current (up to 5.000 A). After tripping, the parallel fuse limits the short-circuit current during the first current rise (in less than 1 ms).

5. How is the main conductor opened in less than a thousandth of a second?

Switching devices with mechanical mechanisms and this high rating are not able to open the main current path in such a short time. For this reason we use an electronically triggered charge as switching mechanism.

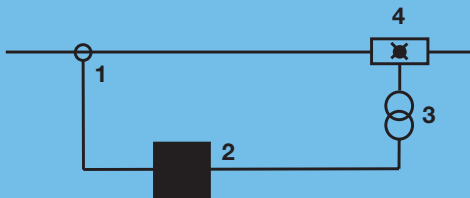

1. Current transformer (detects the short-circuit current)
2. Measuring and tripping device (measures the current and provides the triggering energy)
3. Pulse transformer (converts the tripping pulse to the busbar potential)
4. Insert holder with insert (carries the rated normal current and limits the short-circuit current)

7. Can I_s -limiter inserts be refurbished after interruption of a short-circuit?

Yes! They can be refurbished at the manufacturer's works. The costs are low. The opened main conductor, the parallel fuse and the charge will be replaced. All other parts can be re-used.

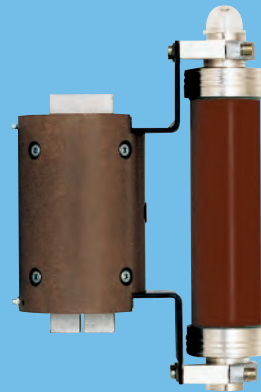

6. Which overvoltage occurs as a result of the sudden interruption of the current?

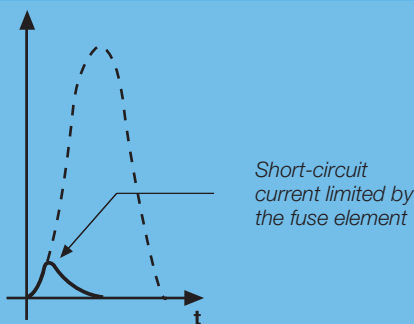

The main conductor is suddenly opened, but not the entire current path. With the opening of the main current path the current commutates to the parallel fuse, which interrupts the current. The overvoltage occurring at the interruption by the fuse is considerably below the permissible levels stated in the IEC / VDE standards, e.g. IEC 60282-1 / VDE 0670 part 4.

8. Does the I_s -limiter trip on every short-circuit?

No! The I_s -limiter only trips when the system is at risk. Small short-circuit currents are interrupted by the circuit-breakers.

9. How does the I_s -limiter distinguish between minor and serious short-circuits?

The measuring and tripping device of the I_s -limiter detects the instantaneous current level **and** the rate of current rise. The I_s -limiter only trips when both set response values are reached.

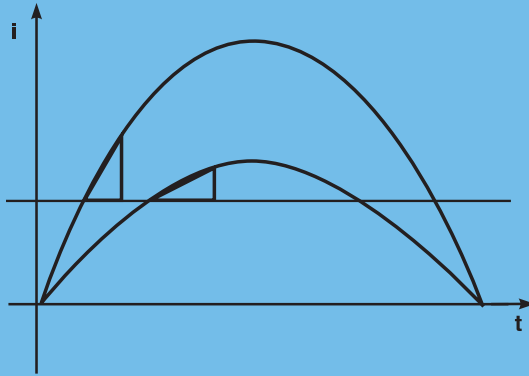

The rate of current rise ($\frac{di}{dt}$)

- is high with high short-circuit currents
- is low with low short-circuit currents

10. What experience is available with the operation of I_s -limiters?

Since the invention of the I_s -limiter by ABB Calor Emag in 1955, several thousand devices have been successfully used in DC, AC and particularly in three phase systems.

We have over 50 years of good operating experience worldwide. More and more customers are selecting the I_s -limiter when they need high short-circuit currents to be safely limited and electrical systems and distribution networks to be economically built or expanded.

11. How often does an I_s -limiter trip?

Experience shows that an I_s -limiter trips once every four years on average (based on a statistic with approximately 3000 I_s -limiters in service).

12. Which short-circuit current the I_s -limiter can interrupt?

Tests at KEMA to date have demonstrated

12 kV	⇒ up to 210 kA _{RMS}
17.5 kV	⇒ up to 210 kA _{RMS}
24 kV	⇒ up to 140 kA _{RMS}
36/40.5 kV	⇒ up to 140 kA _{RMS}

The function and applications of the I_s -limiter are explained in the following pages with various examples. Discuss your short-circuit problems with us. We always find a commercially interesting and technically elegant solution with the I_s -limiter.

The function of the I_s -limiter

The rising demand for energy world-wide requires more powerful or additional transformers and generators, and an increasing interconnection of the individual supply networks. This can lead to the permissible short-circuit currents for the equipment being exceeded and thus parts of the equipment being dynamically or thermally destroyed.

The replacement of existing switchgear and cable connections by new equipment with higher short-circuit strength is often technically impossible or

uneconomical for the user. The use of I_s -limiters reduces the short-circuit current in new systems and expansions to existing systems, thus saving cost.

Circuit-breakers cannot provide any protection against unduly high peak short-circuit currents, as they are too slow. Only the I_s -limiter is capable of detecting and limiting a short-circuit current at the first rise, i.e. in less than 1 ms. The maximum instantaneous current occurring remains well below the level of the peak short-circuit current.

In comparison with complex conventional solutions, the I_s -limiter has both technical and economic advantages when used in transformer or generator feeders, in switchgear sectionalizing and connected in parallel with reactors.

The I_s -limiter is in every regard the ideal switching device to solve the short-circuit problems for switchgear in power stations, in heavy industry and at utilities.



*I_s -limiter connected in parallel with a reactor
– fixed mounted –*

Design

I_s -limiters for three-phase systems basically consist of:

- three I_s -limiter insert holders,
- three I_s -limiter inserts,
- three tripping current transformers,
- a measuring and tripping device.

I_s -limiter insert holders

The I_s -limiter insert holder comprises:

- base plate 1,
- insulator 2,
- insulator with pulse transformer 6 and telescopic contact 5,
- pole heads with clamping device 3 for the reception of the I_s -limiter insert.

The operation of the clamping device will be done with two levers. Only for insert holders $I_r \geq 2500$ A and 12 kV/17.5 kV the inserts are fixed with two bolts.

Pulse transformer

The location of the pulse transformer depends on the rated voltage:

- for ≤ 17.5 kV, in the lower insulator 6 only,
- for 24/36 kV, in the upper and lower insulators.

The pulse transformer transmits the tripping pulse from the tripping device (Figure 3) to the charge 10 in the I_s -limiter insert, and at the same time

ensures electrical isolation of the tripping device from the charge which is on busbar potential.

I_s -limiter insert

The I_s -limiter insert is the switching element. In a sturdy insulating tube 8, the insert contains the main conductor, designed as a bursting bridge 9, which encloses a charge 10. On tripping, this charge is triggered and the main conductor opens at the rupture point.

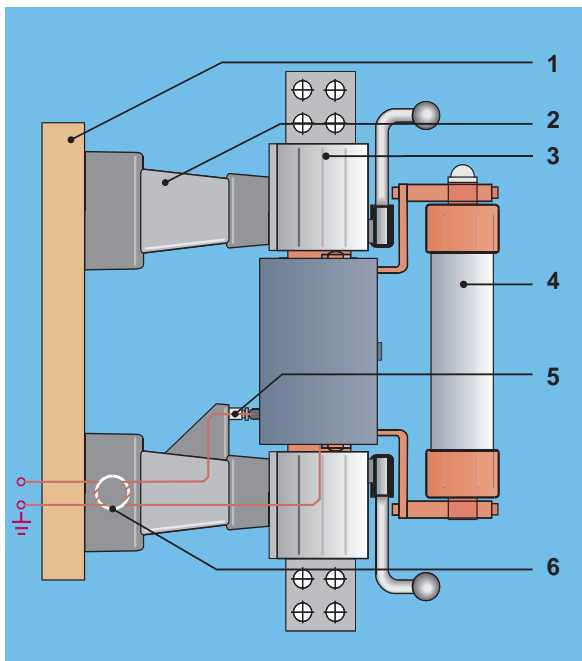

Figure 1: I_s -limiter insert holder with insert for 12 kV, 2000 A

- 1 Base plate
- 2 Insulator
- 3 Pole head with clamping device
- 4 Fuse
- 5 Telescopic contact
- 6 Insulator with pulse transformer

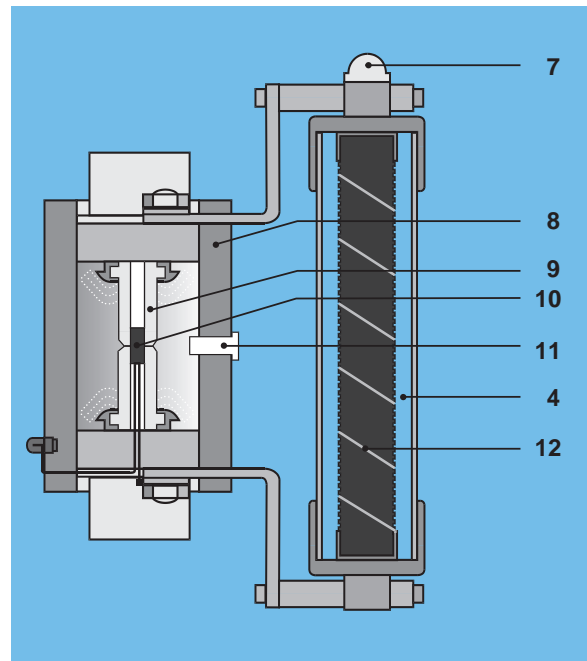

Figure 2: I_s -limiter insert

- 4 Fuse
- 7 Fuse indicator
- 8 Insulating tube
- 9 Bursting bridge
- 10 Charge
- 11 Main conductor indicator
- 12 Fuse element

The current commutates to the parallel high rupturing capacity (HRC) fuse 4. The fuse element 12 in the HRC fuse melts, thus limiting the further current rise. The current is interrupted at the next voltage zero passage.

Tripping current transformer

The tripping current transformers are used to measure the current flowing through the I_s -limiter. They are located directly in series with the I_s -limiter. The I_s -limiter current transformer is externally identical to a conventional current transformer and is designed as a post or bushing type current transformer. Its remarkable features are:

- an extremely high overcurrent factor,
- an iron core with air gap to keep the remanent induction low
- a low impedance shield between the primary and secondary winding.

Measuring and tripping device

The measuring and tripping device is accommodated in a sheet steel control cabinet (Figure 3) or in the low voltage compartment of the I_s -limiter panel. The functional groups within the control cabinet or low voltage compartment are combined such as to form replaceable units and are partly mounted on hinged frames.

The measuring and tripping device includes:

- a power unit to provide the necessary auxiliary DC voltages, a main switch which allows the tripping system to be switched on and off at any time, and additionally a monitoring module,

- one tripping unit for each phase, which monitors the current flowing in the relevant phase and on tripping provides the energy for triggering of the charge in the corresponding I_s -limiter insert,
- an indication unit with five flag indicator relays:
 - one relay per phase for trip signalling,
 - one relay for monitoring of readiness for operation,
 - one relay for monitoring of the supply voltages,
- an anti-interference unit to protect the measuring and tripping assemblies from interference pulses from the outside, which could possi-

ly cause malfunction. The connecting wires from the measuring and tripping device to the current transformers, to the I_s -limiter insert holders and to the AC voltage supplies are routed via the anti-interference unit.

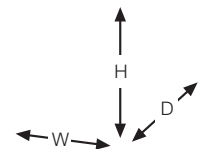

Width (W) : 600 mm
 Height (H) : 1450 mm
 Depth (D) : 300 mm
 Weight : 100 kg

Figure 3: Measuring and tripping device

Function of the I_s -limiter

The I_s -limiter consists in principle of an extremely fast switch, able to carry a high rated current but having a low switching capacity, and a high rupturing capacity (HRC) fuse arranged in parallel. In order to achieve the desired short opening time, a small charge is used as the energy store for opening of the switch (main conductor). When the main conductor is opened, the current continues to flow through the parallel fuse, where it is limited within 0.5 ms and then finally interrupted at the next voltage zero passage.

The current flowing through the I_s -limiter is monitored by an electronic measuring and tripping device. At the **very first** rise of a short-circuit

current, this device decides whether tripping of the I_s -limiter is necessary. In order to reach this decision, the instantaneous current and rate of current rise at the I_s -limiter are constantly measured and evaluated. When the setpoints are simultaneously reached or exceeded, the I_s -limiter trips. The three phases are operated independently of one another. The loss-free conduction of a high operating current on the one hand and the limitation of the short-circuit current at the first current rise on the other hand are made possible by distributing these two functions of the I_s -limiter between two conductors. In comparison with reactors, the I_s -limiter avoids voltage drops and does **not**

contribute to the peak short-circuit current.

Power unit

A DC voltage of 150 V generated in the power unit is used as the charging voltage for the tripping capacitors and at the same time as the supply voltage for the electronics. As far as necessary, the supply voltage is divided and stabilized within the individual assemblies. A watchdog module in the power unit constantly monitors the most important functions of the three tripping units.

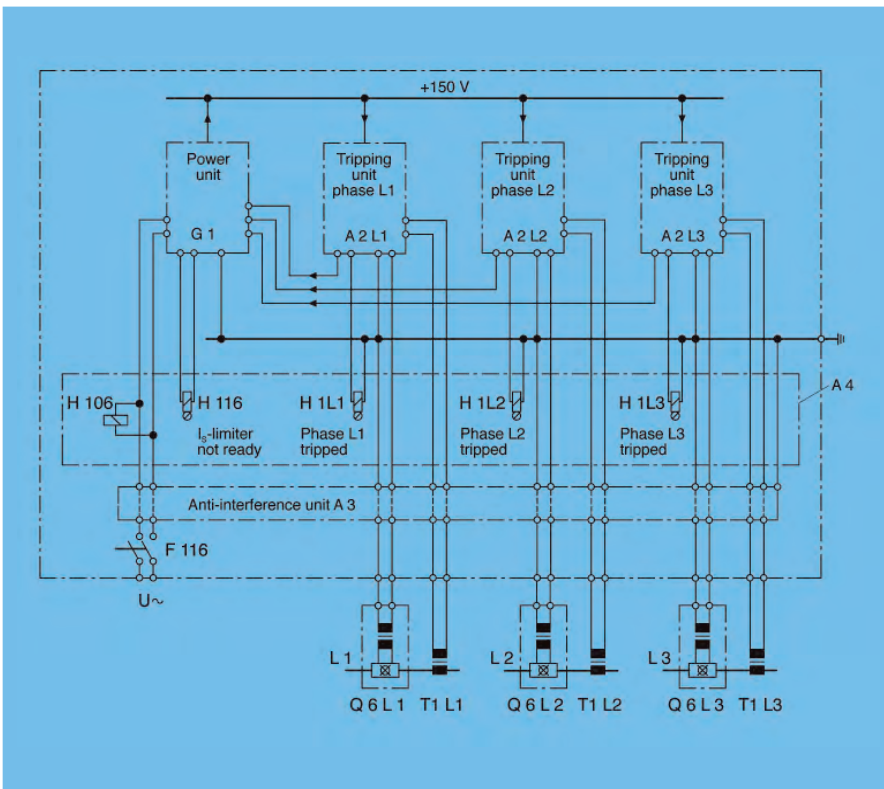

Figure 4: Schematic diagram of the I_s -limiter equipment

G1	Power unit
A2	Tripping units
A3	Anti-interference unit
A4	Indication unit
F116	Miniature circuit-breaker for supply voltage
Q6	I_s -limiter (insert holder and insert)
T1	I_s -limiter tripping transformer

Tripping unit

The current supplied by the tripping transformers for the corresponding phases is monitored in the tripping units. The three tripping units work independently of each other. Both the rate of current rise and the instantaneous current value are used as criteria for tripping.

Both variables are converted into proportional voltages and supplied via logical gates to an electronic measuring element. The latter provides an output signal when the rate of current rise and the instantaneous current value have both simultaneously reached the response value of the measuring element.

The output signal from the measuring element then activates a thyristor, which discharges a capacitor via the pulse transformer in the I_s -limiter insert holder to the charge. At the same time, this discharge excites the corresponding flag indicator relay “ I_s -limiter tripped” in the indication unit.

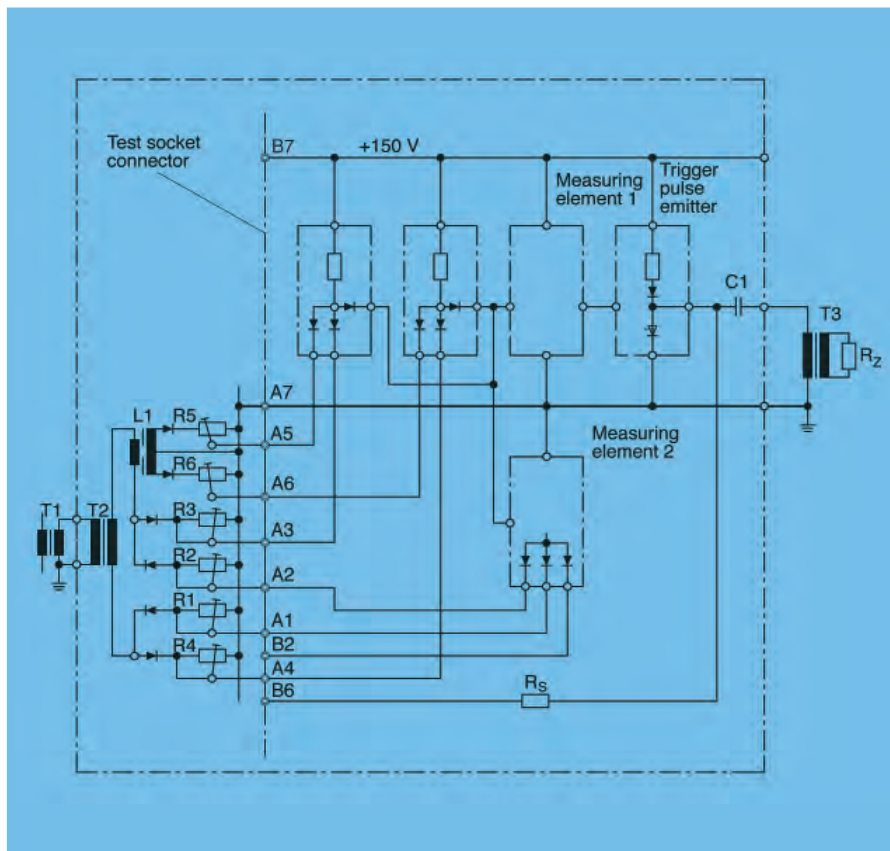

Figure 5: Schematic diagram of a measuring and tripping unit

- | | |
|----------|---|
| T1 | I_s -limiter tripping transformer |
| T2 | Intermediate transformer of the tripping unit |
| T3 | Pulse transformer |
| L1 | Measuring inductance |
| R1 .. R6 | Setting resistors |
| C1 | Tripping capacitor |
| R_s | Discharge resistor |
| R_z | Charge |

Testing the I_s -limiter

As with every other protective device, I_s -limiters should also be checked at regular intervals. There are special testing sets available for those tests which can be performed by the operator or by ABB AG. These test sets consist of a test equipment and a test insert or a test plug and a test insert.

The test plug is used to check the voltages and the functions of the tripping system. The user friendly test equipment facilitates further tests such as determination of the response voltages of the measuring elements, and testing and setting of the modules of the measuring circuits.

During testing, the I_s -limiter insert is replaced by the test insert. The test insert contains a neon lamp as an indicator, which lights up when a tripping pulse is received.

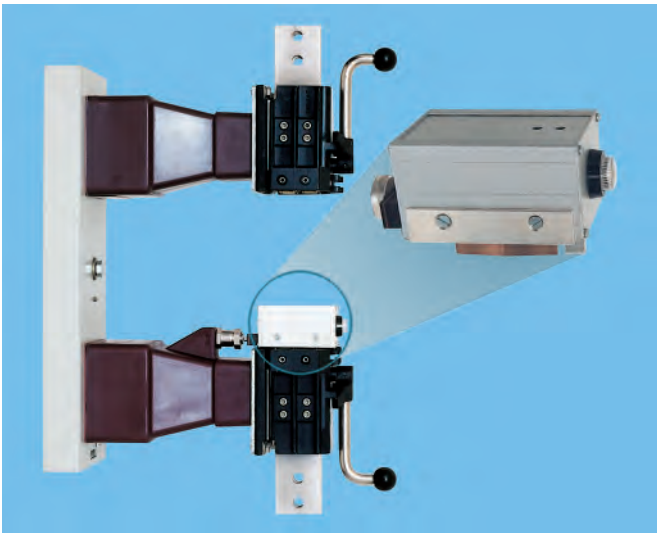

Figure 6: I_s -limiter insert holder with test insert



Figure 7: Test plug



Figure 8: Test equipment

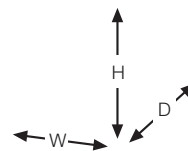

Width (W) : 400 mm
Height (H) : 215 mm
Depth (D) : 320 mm
Weight : 11 kg

The range

A. I_S-limiter as loose equipment supply

In this case the insert holders, the inserts and the tripping current transformers are installed in an already existing panel. The equipment supply generally comprises:

- three insert holders,
- three inserts,
- three tripping current transformers,
- one measuring and tripping device (Figure 3).

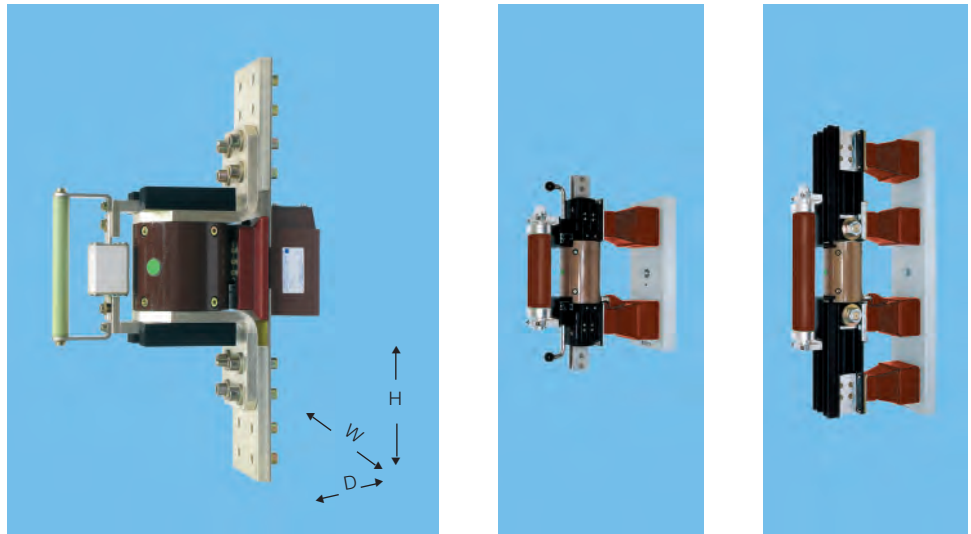

Technical data

Rated voltage	V	690	12000	12000	
Rated current	A	1250/2000/3000/4000 ¹⁾ /5000 ¹⁾	1250/2000	2500/3000/4000 ¹⁾	
Rated power-frequency withstand voltage	kV	3	28	28	
Rated lightning impulse withstand voltage	kV	-	75	75	
Interrupting current	kA _{RMS}	up to 140	up to 210	up to 210	
I _S -limiter insert holder	kg	10.5	23/27.5	65	
I _S -limiter insert	kg	17.0	12/12.5	15.5	
I _S -limiter insert holder	Width W mm	148	180	180	
	Height H mm	554	637/651	951	
with insert	Depth D mm	384	503/510	509	

¹⁾ With cooling fan

Frequency: 50/60 Hz

For higher rated currents, insert holders with inserts are connected in parallel.

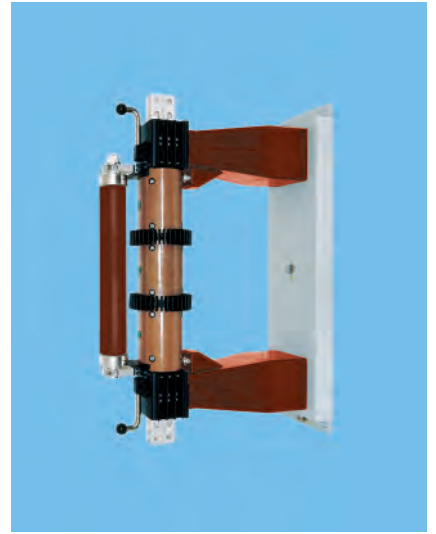
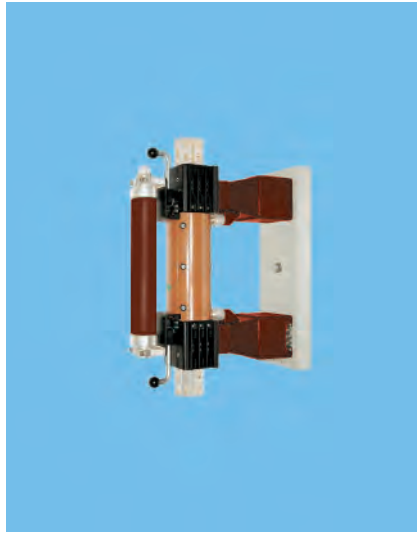
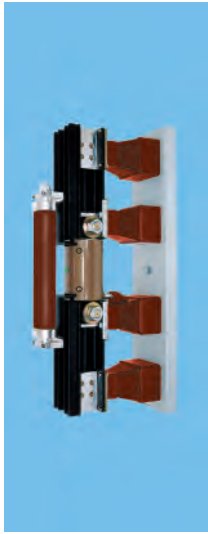
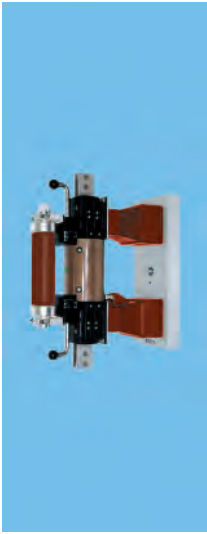

	17500	17500	24000	36000/40500
	1250/2000	2500/3000/4000 ¹⁾	1250/1600/2000/3000 ¹⁾	1250/2000/2500 ¹⁾
	38	38	50	75
	95	95	125	200
	up to 210	up to 210	up to 140	up to 140
	23/27.5	65	27/31.5/33	60
	14/14.5	17.5	19/19.5/24	42
	180 637/651 503/510	180 951 509	180 740/754/837 553/560/560	240 1016 695

B. Truck mounted I_s -limiter in a switchgear panel

The I_s -limiters can also be installed in a metal-clad switchgear panel. The withdrawable truck with the three I_s -limiter insert holders and inserts has the

function of a disconnecter. The three tripping current transformers are fixed mounted in the panel and the measuring and tripping device is mounted in the low voltage compartment.



Truck mounted I_s -limiter in a switchgear panel

I_s-limiter panels with truck

Rated voltage kV	Rated current A	Rated power-frequency withstand voltage kV	Rated lightning impulse withstand voltage kV	Dimensions			Weight including I _s -limiter truck kg
				Height mm	Width mm	Depth mm	
12	1250	28	75	2200	1000	1300	approx. 1200
	2000						
	2500						
	3000 ¹⁾						
	3000					1350	
4000 ¹⁾	1350						
17.5	1250	38	95	2200	1000	1300	approx. 1200
	2000						
	3000 ¹⁾						
	3000					1350	
	4000 ¹⁾					1350	
24	1250	50	125	2325	1000	1500	approx. 1300
	1600						
	2000						
	2500 ¹⁾						

¹⁾ With cooling fan.

For higher currents, insert holders with inserts are connected in parallel.

C. Fixed mounted I_s-limiter in a switchgear panel

The I_s-limiters for low voltage, 12 kV, 17.5 kV and 24 kV are also available as fixed mounted equipment in a metal-enclosed switchgear panel. The three I_s-limiter insert holders with the I_s-limiter inserts and the three tripping current transformers are fixed mounted in the panel. The measuring and tripping device is mounted in the low voltage compartment.

The I_s-limiter (fixed mounted) for 36 kV/40.5 kV is available in a metal-enclosed switchgear panel. Same as for loose equipment supply, the measuring and tripping device is installed in a separate sheet steel cabinet (Figure 3).

For all fixed mounted I_s-limiters the electrical data are the same as for loose equipment supply. Dimensions and weights on request.

Applications

I_s -limiters in system interconnections

I_s -limiters are frequently used in interconnections between systems or in bus sections which would not be adequately short-circuit proof when connected by a circuit-breaker. Each partial system should have at least one incoming feeder, so that power supply to each partial system can be maintained on tripping of the I_s -limiter (Figure 9).

There is a large number of advantages for the operation under normal conditions of bus sections connected by I_s -limiters:

- Reduction of the series network impedance. The voltage drops caused by load surges (e.g. of starting of motors) can be significantly reduced.

- Improvement of the current distribution at the feeder transformers.
- The load dependent losses of the feeder transformers are reduced.
- Increased reliability of the power supply. On failure of one feeder transformer, the load is taken over by the other feeder transformers without current interruption. The cost for an otherwise required new switchboard with higher short-circuit capacity will be saved.

If a short-circuit occurs within a system or in an outgoing feeder, the I_s -limiter trips at the first rise of the short-circuit current and divides the busbar system into two sections before the instantaneous current reaches an inadmissible high level. After tripping of the I_s -limiter, the

short-circuit is only fed by the transformer in the part of the system affected by the short-circuit. The short-circuit current is now selectively interrupted by the circuit-breaker.

A remarkable advantage of the use of an I_s -limiter is that the voltage in the part of the system not affected by the short-circuit only drops for a fraction of a millisecond so that even sensitive loads (e.g. computers) remain protected from drops in the system voltage.

For this reason the I_s -limiter can also excellently be used as a reliable switchgear suitable between an "unprotected" and a "protected" switchboard or section of a switchboard.

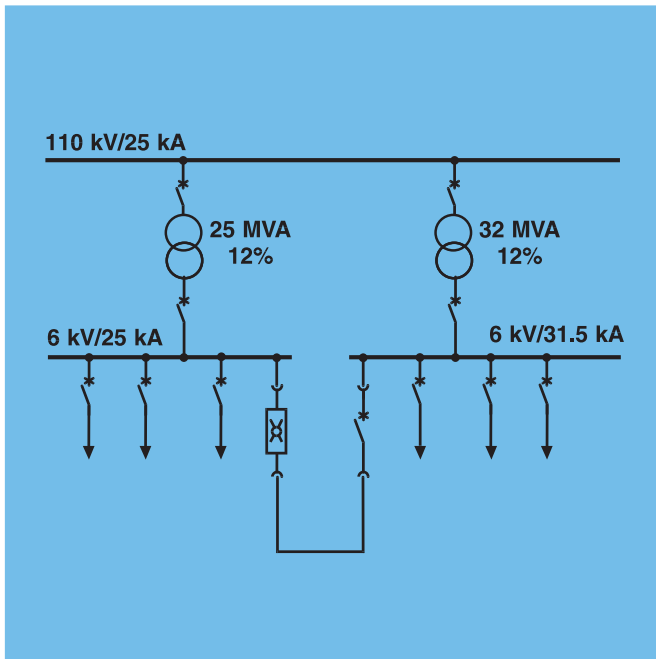

Figure 9: I_s -limiter in a bus section

I_s -limiters used as a link between public networks and consumer owned power supply systems

The decentralization of power supply leads to systems with their own power generating facilities being interconnected with public supply networks. The additional short-circuit current from generators leads to the permissible short-circuit current in the utility network being exceeded. The most appropriate technical solution – and mostly the only one – is the installation of an I_s -limiter in the interconnection with the public utility network (Figure 10). If necessary, the I_s -limiter can be provided with a directional tripping criterion. This requires

three additional current transformers in the neutral connections of the generators. The I_s -limiter then only trips on short-circuits in the public supply network if a generator is in operation.

I_s -limiter in parallel with a reactor

The I_s -limiter can also be connected in parallel with a reactor (Figure 11). If a short-circuit occurs behind the reactor, the I_s -limiter trips and the current commutates at the first current rise to the parallel reactor, which then limits the short-circuit current to the permissible level. For normal operation, the I_s -limiter bridges the reactor coil.

- This avoids:
- Current dependent copper losses and the associated operating costs of the reactor.
 - Current dependent voltage drop at the reactor, which frequently causes major difficulties on start-up of big motors.
 - Control problems with the generator.

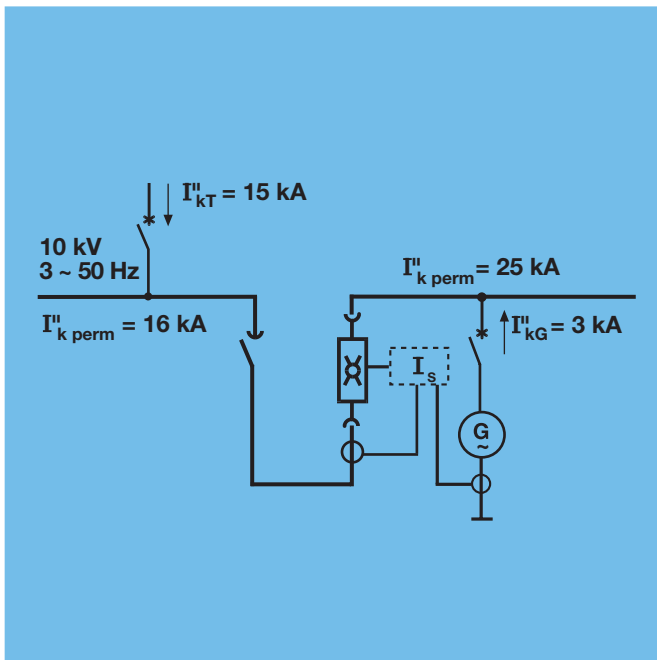

Figure 10: I_s -limiter in connecting point with a public supply network

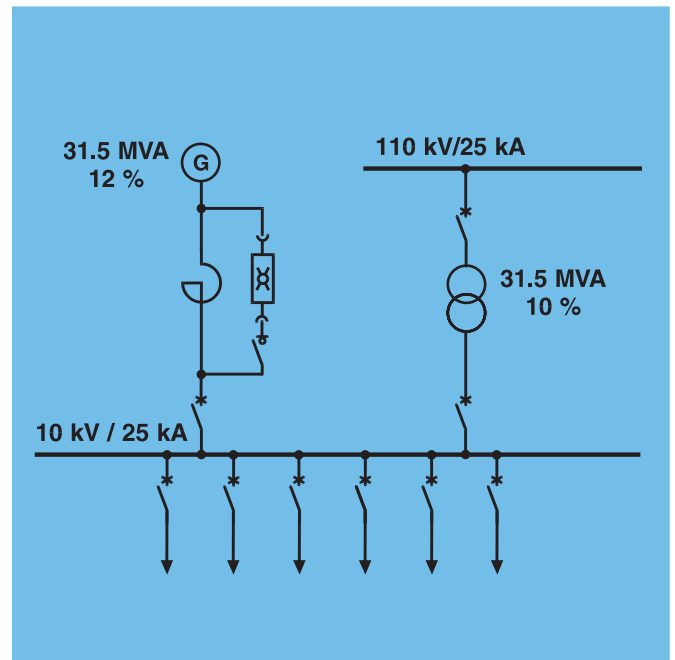

Figure 11: I_s -limiter in parallel with a reactor in a generator feeder

Use of more than one I_S -limiter with selectivity

In order to achieve selectivity in a switchboard or switchboards with more than one I_S -limiter installed, additional tripping criteria as current summation or differences or comparison of current directions are required. If in case of two I_S -limiters installed in a switchboard selective tripping is required, a measurement of the total current becomes necessary.

The I_S -limiter trips as follows:

- Short-circuit in section A: Only I_S -limiter no. 1 trips.
- Short-circuit in section B: I_S -limiter no. 1 and no. 2 trip.
- Short-circuit in section C: Only I_S -limiter no. 2 trips.

For measurement of the total current, transformer feeders

must be additionally equipped with one CT set each. The total current I_{sum1} is equal to the current (I_{T1}) of transformer T1 plus the current (I_{IS-1}) flowing through the I_S -limiter 1. The total current I_{sum2} is equal to the current of transformer T2 plus the currents flowing through I_S -limiter 1 and 2. The total current I_{sum3} is equal to the current of transformer T3 plus the current flowing through I_S -limiter 2. The tripping criteria of the I_S -limiters correspond to a logic "and" function. The I_S -limiter 1 trips in case of short-circuits in section A, if the current of I_S -limiter 1 and the total current I_{sum1} reach or exceed their response values simultaneously. The same is applicable for section C. In case of a short-

circuit in section B I_S -limiters 1 and 2 trip. The summation of the currents corresponds to the principle of the adding up of currents in a busbar protection system. The only difference is the non-requirement of current transformers in the outgoing feeders, i.e. the requirement of material is negligible. With this principle up to 5 transformers have so far been connected in parallel, using 4 I_S -limiters only. The principle ensures that always only the I_S -limiter or these I_S -limiters trip, which are closest to the point of short-circuit.

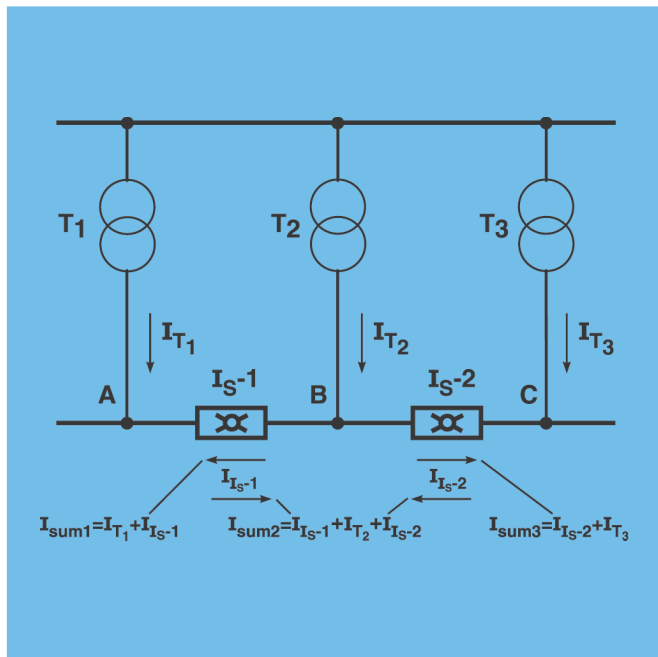

Figure 12: Schematic diagram- I_S -limiter with summation of currents

Contact us

ABB AG

Calor Emag Medium Voltage Products

Oberhausener Strasse 33 Petzower Strasse 8
40472 Ratingen 14542 Werder (Havel) OT Glindow
GERMANY GERMANY
Phone: +49 2102 12-0
Fax: +49 2102 12-1777
E-Mail: powertech@de.abb.com
Internet: <http://www.abb.com/mediumvoltage>

Note:

We reserve the right to make technical changes or modify the contents of this document without prior notice. With regard to purchase orders, the agreed particulars shall prevail. ABB AG does not accept any responsibility whatsoever for potential errors or possible lack of information in this document.

We reserve all rights in this document and in the subject matter and illustrations contained therein. Any reproduction, disclosure to third parties or utilization of its contents – in whole or in parts – is forbidden without prior written consent of ABB AG.

Copyright© 2009 ABB
All rights reserved