

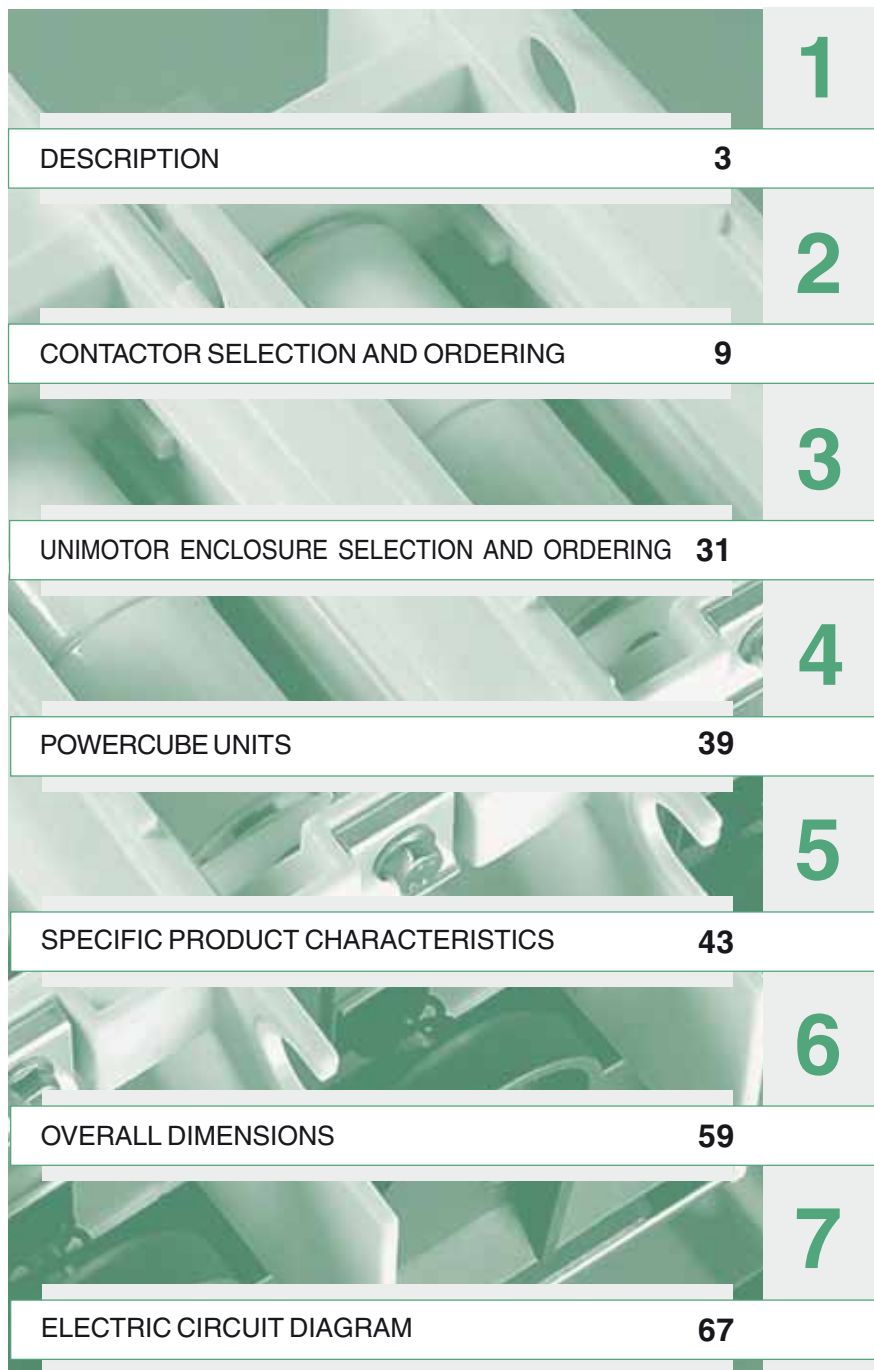


Medium Voltage Products

# V-Contact

## Medium voltage vacuum contactors



The background of the table is a close-up photograph of electrical components, likely a motor or control unit, with various wires, connectors, and metal parts visible. The image is overlaid with a semi-transparent green filter.

	<b>1</b>
DESCRIPTION	<b>3</b>
	<b>2</b>
CONTACTOR SELECTION AND ORDERING	<b>9</b>
	<b>3</b>
UNIMOTOR ENCLOSURE SELECTION AND ORDERING	<b>31</b>
	<b>4</b>
POWERCUBE UNITS	<b>39</b>
	<b>5</b>
SPECIFIC PRODUCT CHARACTERISTICS	<b>43</b>
	<b>6</b>
OVERALL DIMENSIONS	<b>59</b>
	<b>7</b>
ELECTRIC CIRCUIT DIAGRAM	<b>67</b>



## DESCRIPTION

General	4
Available versions	5
Fields of application	6
Quality Assurance System	6
Environmental Management System	6
Health and Safety Management System	6
Test laboratory	6
Compliance with Standards	6
Approvals	6
Operating characteristics	6
Main technical characteristics	6
Electrical life	6
Interruption principle	7
Technical documentation	8

## DESCRIPTION

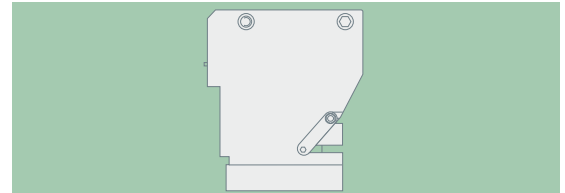
### General

The MV V-Contact series are apparatus suitable for operating in a.c. They are normally used to control users requiring a high number of hourly operations. The contactors basically consist of a moulded resin monobloc containing the vacuum interrupters, the moving parts, the electromagnet, the multi-voltage control feeder and the auxiliary accessories.

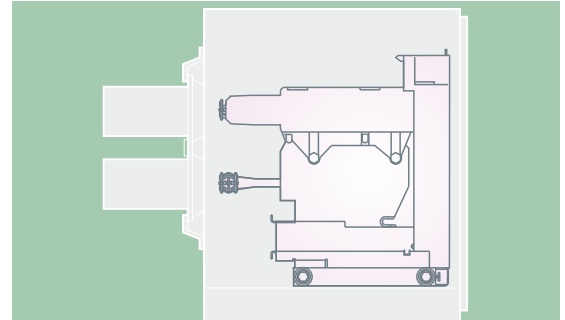
The monobloc is the support for assembly of the fuse-holder frame. Closing of main contacts is carried out by means of the control electromagnet. Opening is carried out by means of a special counteracting spring.

Construction is compact and sturdy and ensures very long electrical and mechanical life, even without maintenance.

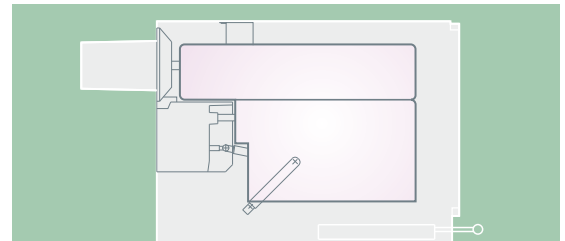
The accessories allow the contactor to be easily personalised and facilitate stock management. The V-Contact contactors are interchangeable with the withdrawable VRC series contactors and guarantee the same performances are covered (Check interchangeability of the electric diagram). Retrofit kit for the enclosure, available on request, is needed for the UniMotor version.



Fixed.



Withdrawable for CBE/PowerCube enclosure.



Withdrawable for UniMotor enclosure.



### Available versions

The V-Contact are fitted with electrical latching as standard and are available for rated voltages of 7.2 kV (V7) and 12 kV (V12), in the following versions:

- fixed (which can be supplied, on request, with a fuse-holder frame)
- single-pole fixed (for earthing the star centre of the transformers - application of the fuse-holder frame is not provided)
- withdrawable for CBE enclosure and PowerCube unit
- withdrawable for UniMotor enclosure and switchgear
- withdrawable for ZS1 and UniGear ZS1 type switchgear.

The withdrawable versions consist of a contactor fitted with a withdrawable truck and power circuit isolating contacts.

The fuse-holder frame is standard for withdrawable contactors, on request for fixed contactors and is normally preset for installation of fuses with dimensions, average type of striker and electrical characteristics in compliance with CENELEC EN 60282-1 (94) Standards.

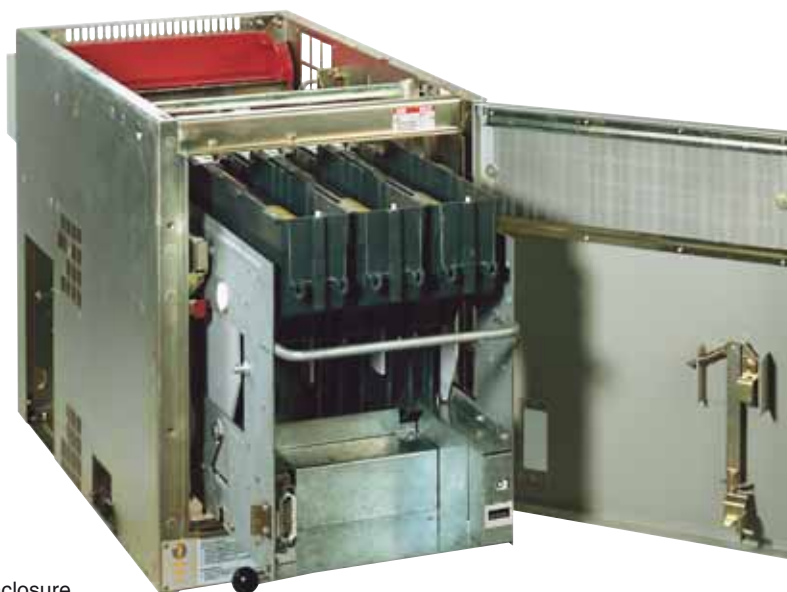
The contactors can be coupled with the following fuses:

- V7 with fuses from 6 A to 450 A (up to 315 A for motor protection; up to 450 A for capacitor bank protection)
- V12 with fuses from 6 A to 200 A.



PowerCube series unit.

The fuse-holder frames are fitted with an automatic opening device when even a single fuse blows. The same device also prevents closure of the contactor in the case when even a single fuse is missing.



UniMotor series enclosure.

## DESCRIPTION

### Fields of application

The V-Contact series of contactors are used for controlling electrical apparatus in industry, in the service sector, in the marine sector, etc. Thanks to the vacuum interrupter breaking technique, the contactors can operate in particularly difficult environments. They are suitable for control and protection of motors, transformers, power factor correction banks, switching systems, etc. Fitted with suitable fuses, they can be used in circuits with fault levels up to 1000 MVA.



Fixed version V-Contact.

### Quality Assurance System

Certified by an external independent organization as complying with ISO 9001 Standards.

### Environmental Management System

Certified by an external independent organization as complying with ISO 14001 Standards.

### Health and Safety Management System

Certified by an external independent organization as complying with OHSAS 18001 Standards.

### Test laboratory

Accredited by an external independent organization as complying with UNI CEI EN ISO/IEC 17025 Standards.

### Compliance with Standards

The V-Contact contactors comply with the Standards of the major industrialised countries and in particular with:

- IEC 60470 (2000) and IEC 632-1 (1978) for the contactor
- IEC 282-1 / CENELEC EN 60282-1 (1994) for the fuses
- IEC 298 for the enclosures.

### Approvals

The contactors are approved by RINA, LL.RR. and DNV shipping registers.

### Operating characteristics

- Ambient temperature:  $-5\text{ °C} \dots +40\text{ °C}$
- Relative humidity:  $\leq 95\%$
- Altitude:  $\leq 1000\text{ m a.s.l.}$

For other conditions, please contact us.

### Main technical characteristics

- Chopping current value  $\leq 0.5\text{ A}$
- Maintenance-free
- High number of operations
- Long electrical and mechanical life
- Direct checking of contact wear
- Remote control
- Possibility of integration in computerised control systems
- Suitable for installation in prefabricated substations and switchgear
- Multi-voltage feeder.

### Electrical life

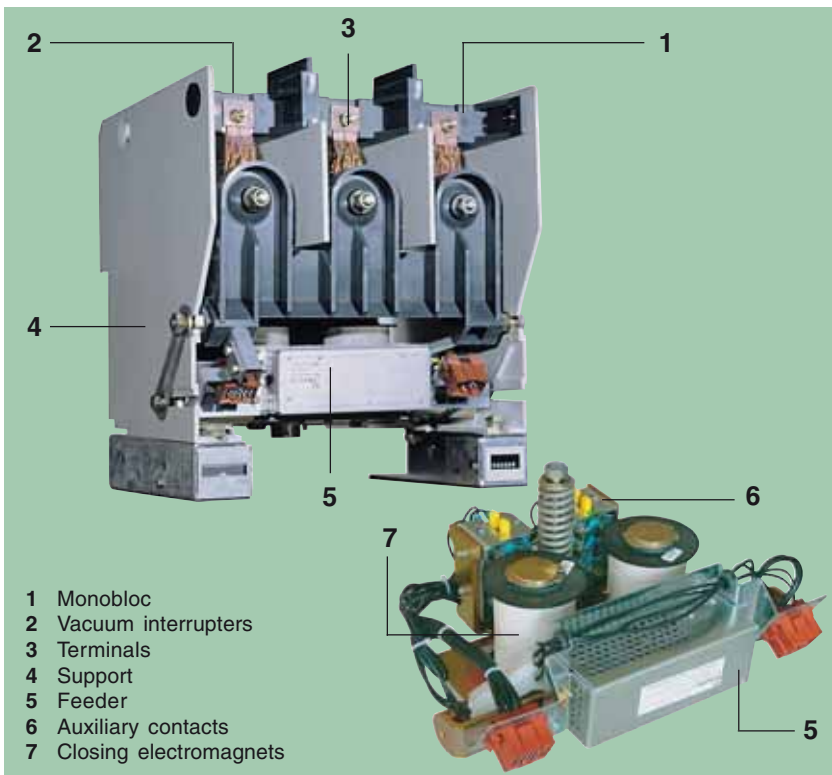
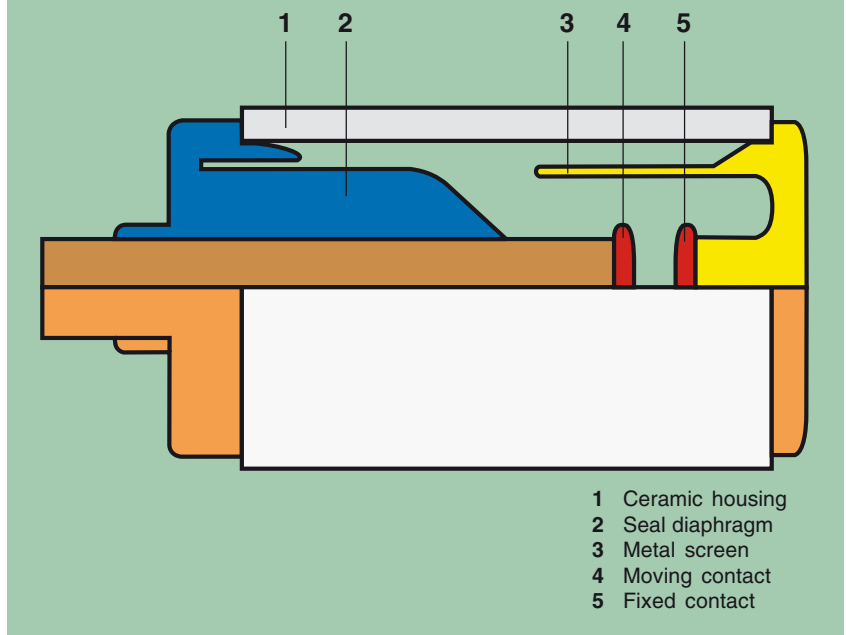
The electrical life of V-Contact contactors is defined in category AC3 with 100,000 operations (closing-opening), interrupted current 400 A, closing current 2.4 kA, and  $\cos\varphi = 0.35$ .

## Interruption principle

The main contacts of the contactor operate inside the vacuum interrupters (the level of vacuum is extremely high:  $13 \times 10^{-5}$  Pa).

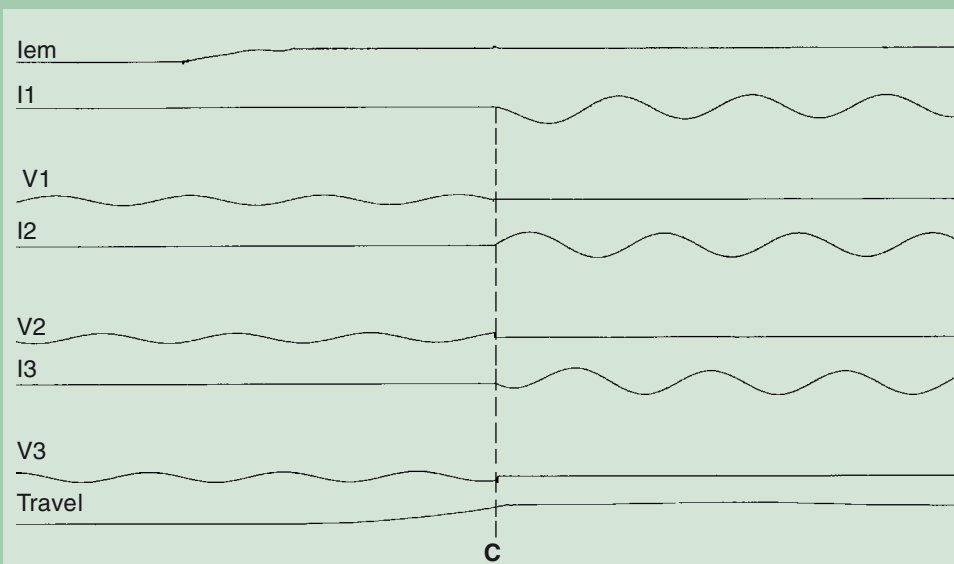
On opening, there is rapid separation of the fixed and moving contacts in each contactor interrupter. Overheating of the contacts, generated at the moment they separate, causes formation of metallic vapours which allow the electric arc to be sustained up to the first zero current passage. On passage of zero current, cooling of the metallic vapours allows recovery of high dielectric rigidity able to withstand high values of return voltage. In the version for motor switching, the value of the chopped current is less than 0.5 A with extremely limited overvoltages.

Schematic cross-section of the vacuum interrupter.

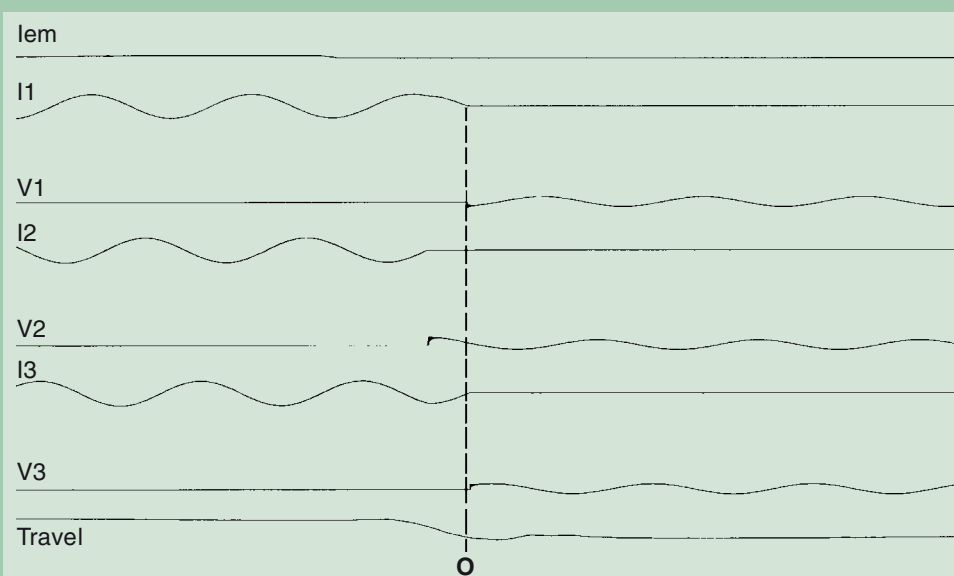


## DESCRIPTION

## Oscillogram of short-circuit test Travel



## Oscillogram of short-circuit test Travel



Contactor: V-Contact V7  
 Voltage: 7.2 kV  
 Current: 4000 A  
 $V_1 - V_2 - V_3$ : R-S-T phase voltage  
 $I_1 - I_2 - I_3$ : R-S-T phase current  
*I<sub>em</sub>*: Control electromagnet current  
 C: Circuit closure  
 O: Circuit interruption

## Technical documentation

For more in-depth knowledge of the technical and application aspects of the V-Contact series contactors, the following technical catalogues are available:

- UniGear switchgear Code 1VCP000138
- UniMotor switchgear Code 1VCP000079

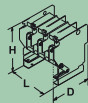
## CONTACTOR SELECTION AND ORDERING

General characteristics	10
Standard fittings	11
Contactors ordering codes	12
Accessory ordering codes	13

# CONTACTOR SELECTION AND ORDERING

## General characteristics

Values and characteristics		Reference to IEC 60470 Standard	V-Contact V7			
			Contactor 3.4.105	Starter 3.4.110	Combined with fuses 3.4.110.9	
Rated voltage	Ur [kV]	4.1	7.2	7.2	7.2	
Rated insulation voltage						
Withstand voltage at 50 Hz	Ud (1 min) [kV]	4.2	20	20	20	
Impulse withstand voltage (1)	Up [kVp]	4.2	60	60	60	
Rated frequency	fr [Hz]	4.3	50-60	50-60	50-60	
Rated service current (2)	Ie [A]	4.101	400	400	400	
Short-time withstand current						
Short-time withstand current for 1 s	Ik [A]	4.5	6000	6000	6000	
Short-time withstand current for 30 s	Ik [A]	4.5	2500	2500	2500	
Rated peak current	I <sub>p</sub> [kA peak]	4.6	15	15	15	
Rated short-circuit time (tk)	tk [s]	4.7	1	1	1	
Breaking capacity up to (Isc)	Isc [kA]	4.107	–	–	50 (3)	
Making capacity under short-circuit up to (I <sub>ma</sub> )	I <sub>ma</sub> [kA]	4.107	–	–	50 (3)	
Rated values						
Contactor with electrical latching (4)	[op./hour]	4.102	900	900	900	
Contactor with mechanical latching (5)	[op./hour]	4.102	300	300	300	
Rated maximum overcurrent withstand for 1/2 period (peak value)	[kA]	–	55	–	–	
Rated load and overload characteristics in category of use:						
(Category AC4) 100 closing operations	[A]	4.103, 4.104	4000	4000	4000	
(Category AC4) 25 opening operations	[A]	4.103, 4.104	4000	4000	4000	
Rated voltage of the operating devices and auxiliary circuits		4.8, 4.9				
Feeder type 1 (24 ... 60 DC)			■	■	■	
Feeder type 2 (100 ... 250 AC-DC)			■	■	■	
Normal current	I <sub>th</sub> [A]	4.4.101	400	400	(2)	
Electrical life (category AC3) (6)		4.106	100,000	–	–	
Electrical life at rated current (electrical latching)		4.106	1,000,000	–	–	
Coordination with protection devices against short-circuit		4.107	(7)	(7)	(7)	
Apparatus wear classification (type)		4.107.3	C	C	C	
Breaking capacity under short-circuit (single cycle O-3min-CO-3min-CO)	[A]	4.107, 6.104	6000	6000	–	
Making capacity under short-circuit (single cycle O-3min-CO-3min-CO)	[A peak]	4.107, 6.104	15000	15000	–	
Limit above which the fuse blows (10)	[A]	4.107.2	–	–	5000	
Ultimate performances for (at a voltage of):	[kV]		<b>2.2/2.5</b>	<b>3.3</b>	<b>3.6/5</b>	<b>6,2/7,2</b>
- motors	[kW]		1000	1500	1500	3000
- transformers	[kVA]		1100	1600	2000	4000
- capacitors	[kVAr]		1000	1500	1500	3000
Ultimate performances for back-to-back capacitor banks						
- rated current	[A]			250		
- maximum transient capacitor bank switching-in current	[kA]			8		
- maximum transient capacitor bank switching-in frequency	[kHz]			2.5		
Opening time with electrical latching (8)	[ms]			15 ... 25		
Opening time with mechanical latching (8)	[ms]			15 ... 20		
Closing time (8)	[ms]			40 ... 80		
Weights fixed / fixed with fuse-holders (9)	[kg]			25/40		
withdrawable for CBE, CBF, PowerCube, UniGear ZS1 type (9)	[kg]			55		
withdrawable for UniMotor (9)	[kg]			45		
Overall dimensions						
fixed / fixed with fuse-holders	(HxLxD) [mm]			398 x 365 x 350		
withdrawable for CBE, CBF, PowerCube, UniGear ZS1 type	(HxLxD) [mm]			636 x 532 x 600		
withdrawable for UniMotor	(HxLxD) [mm]			508 x 383 x 768		
Tropicalisation	IEC 721-2-1			■		



### V-Contact V12

Contactor	Starter	Combined with fuses 3.4.110.9
3.4.105	3.4.110	
12	12	12
28	28	28
60	60	60
50-60	50-60	50-60
400	400	400
6000	6000	6000
2500	2500	2500
15	15	15
1	1	1
–	–	50 (3)
–	–	50 (3)
900	900	900
300	300	300
55	–	–
4000	4000	4000
4000	4000	4000
–	–	–
■	■	■
400	400	(2)
100,000	–	–
1,000,000	–	–
(7)	(7)	(7)
C	C	C
4000	4000	–
8000	8000	–
–	–	5000

12  
5000  
5000  
4800 (11)

230  
8  
2.5  
15 ... 25  
15 ... 20  
40 ... 80  
25/40  
55  
45

398 x 365 x 350  
636 x 532 x 600  
508 x 383 x 768



### Standard fittings

As standard, the contactors are fitted with:

- operating mechanism with electrical latching
- mechanical open/closed signalling
- six pairs of open/closed signalling contacts (six break contacts plus six make contacts)
- multi-voltage feeder (**type 1**: 24-60 V d.c. for V-Contact V7 only; **type 2**: 100-250 V d.c./a.c. 50-60 Hz)
- basic cabling with socket
- cabled plug with 3 m long cord.

And, moreover, only for withdrawable contactor:

- plug connector
- fuse-holders, with electric release device preset for installation of fuses in compliance with DIN Standards with cartridge length **e = 442 mm**, or BS Standards with cartridge length **L = 553 mm**. For shorter fuses, special adaptation kits must be ordered (see accessories)
- tool for removing the DIN type fuses
- mechanical release device for fuse intervention.



Fixed version V-Contact.

- (1) 75 kV BIL only for fixed V12 contactor. For the withdrawable versions for UniGear or PowerCube switchgear or for PowerCube or CBE enclosures, the 75 kV BIL insulation level is available on request.
- (2) Rated service current defined for fixed contactors; for the contactors coordinated with fuses, the limits are as follows:
  - 7.2 kV in ABB 250 A units with maximum fuse size (315 A)
  - 12 kV in ABB 160A units with maximum fuse size (200 A).
- (3) For the breaking capacity of the coordinated fuses, please see the following pages.
- (4) Mechanical life (opening/closing cycles) 1,000,000.
- (5) Mechanical life (opening/closing cycles) 250,000.
- (6) Electrical life which can be obtained following the programmed maintenance plan in the product instruction manual.
- (7) Coordination is guaranteed with the types of fuses indicated on the following pages.
- (8) Lower and upper limits.
- (9) Fuses excluded (the maximum fuse size weighs 5.5 Kg).
- (10) This is the current value determined by the intersection of the time-current trip curve of two protection devices; in this case the fuse and any thermal protection relay.
- (11) Application of overvoltage surge arresters or RC filters is necessary.

## CONTACTOR SELECTION AND ORDERING

### Contactor ordering codes

#### V-Contact

##### Fixed with electrical latching

U [kV]	In [A]	Feeder type	V-Contact	1VCF
7,2	400	1 (24 ... 60 V –)	V7	304111R0100
		2 (100 ... 250 V – / ~)	V7	304111R0200
12	400	2 (100 ... 250 V – / ~)	V12	304112R0200

##### Fixed single-pole with electrical latching (transformer star centre earthing)

U [kV]	In [A]	Feeder type	V-Contact	1VCF
7,2	400	1 (24 ... 60 V –)	VU7	304211R0100
		2 (100 ... 250 V – / ~)	VU7	304211R0200
12	400	2 (100 ... 250 V – / ~)	VU12	304212R0200

##### Withdrawable with electrical latching for CBF11, CBE11

U [kV]	In [A]	Feeder type	V-Contact	1VCF
7,2	400	1 (24 ... 60 V –)	V7/C	304161R0100
		2 (100 ... 250 V – / ~)	V7/C	304161R0200
12	400	2 (100 ... 250 V – / ~)	V12/C	304162R0200

##### Withdrawable with electrical latching for ZS1 switchgear

U [kV]	In [A]	Feeder type	V-Contact	1VCF
7,2	400	1 (24 ... 60 V –)	V7/Z	304151R0100
		2 (100 ... 250 V – / ~)	V7/Z	304151R0200
12	400	2 (100 ... 250 V – / ~)	V12/Z	304152R0200

##### Withdrawable with electrical latching for UniGear ZS1 type switchgear

U [kV]	In [A]	Feeder type	V-Contact	1VCF
7,2	400	1 (24 ... 60 V –)	V7/P	304181R0100
		2 (100 ... 250 V – / ~)	V7/P	304181R0200
12	400	2 (100 ... 250 V – / ~)	V12/P	304182R0200

##### Withdrawable with electrical latching for PowerCube modules

U [kV]	In [A]	Feeder type	V-Contact	1VCF
7,2	400	1 (24 ... 60 V –)	V7/W	304171R0100
		2 (100 ... 250 V – / ~)	V7/W	304171R0200
12	400	2 (100 ... 250 V – / ~)	V12/W	304172R0200

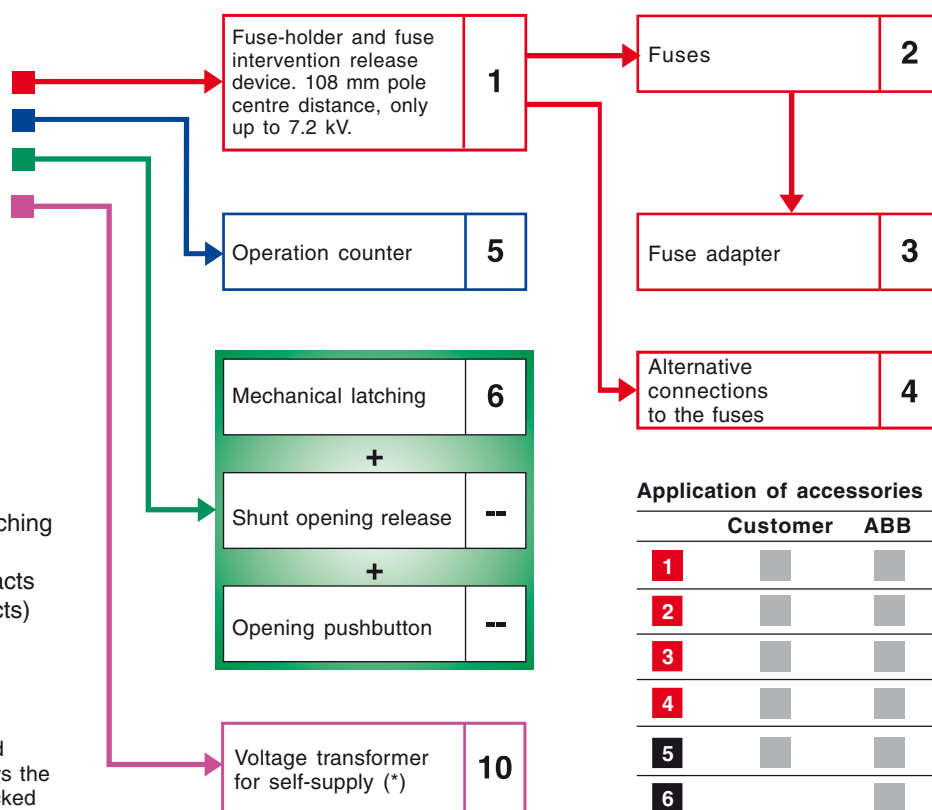
## V-Contact

### Withdrawable with electrical latching UniMotor enclosures/switchgear

U [kV]	In [A]	Feeder type	V-Contact	1VCF
7.2	400	1 (24 ... 60 V –)	V7/UN	304131R0100
		2 (100 ... 250 V – / ~)	V7/UN	304131R0200
12	400	2 (100 ... 250 V – / ~)	V12/UN	304132R0200

## Accessory ordering codes

### Accessories which can be combined for fixed contactor



### Standard fittings

- operating mechanism with electrical latching
- mechanical open/closed signalling
- six pairs of open/closed signalling contacts (six break contacts plus six make contacts)
- multi-voltage feeder
- basic cabling with socket
- plug with cord 3 m long.

**N.B.:** the interlock between two superimposed contactors has to be made electrically. It allows the operations of the two contactors to be interlocked with each other and is suitable, for example, for use in circuits with automatic commutation.

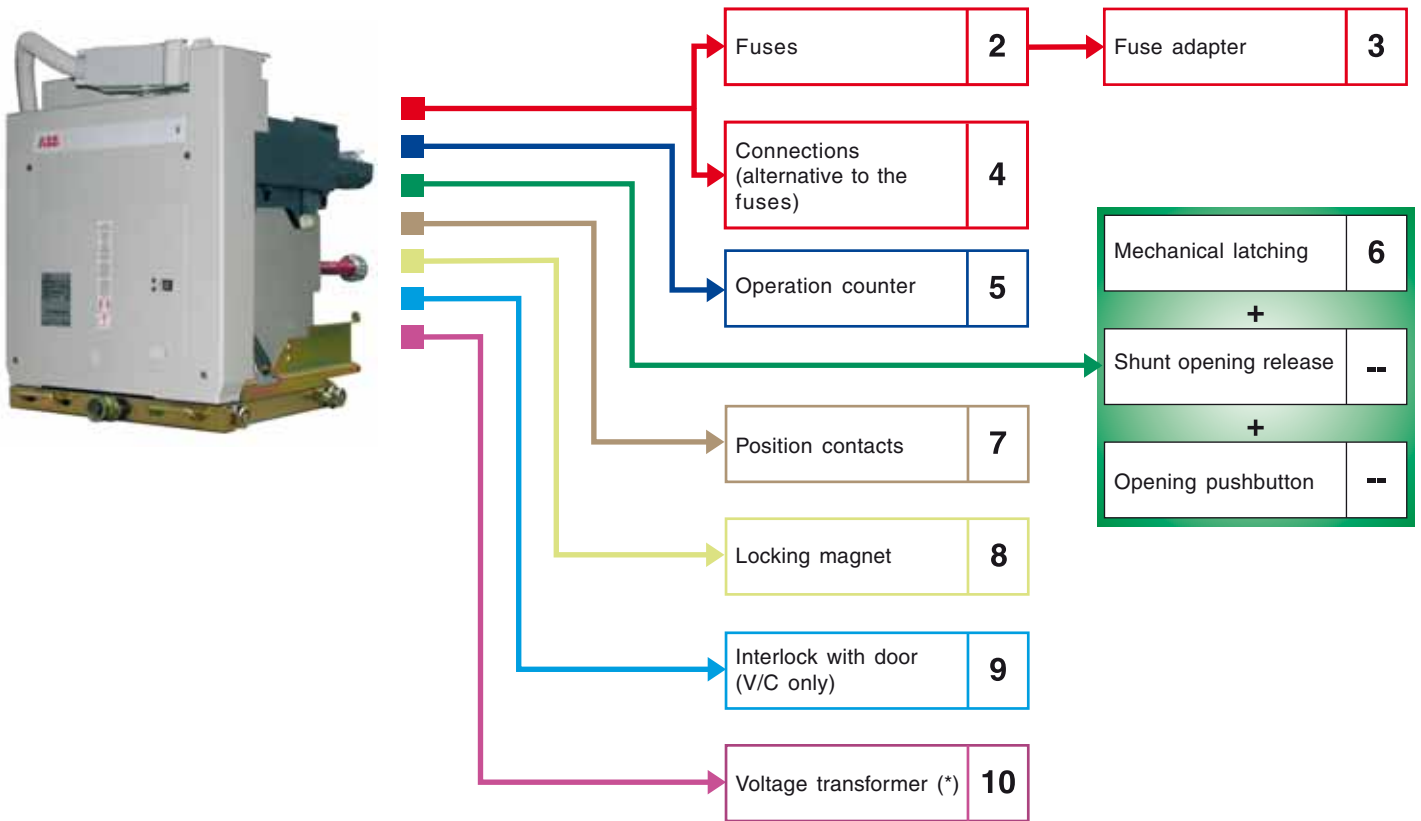
(\*) The voltage transformer receives the power supply from the upper poles of the contactor.

### Application of accessories

	Customer	ABB
<b>1</b>	<input type="checkbox"/>	<input type="checkbox"/>
<b>2</b>	<input type="checkbox"/>	<input type="checkbox"/>
<b>3</b>	<input type="checkbox"/>	<input type="checkbox"/>
<b>4</b>	<input type="checkbox"/>	<input type="checkbox"/>
<b>5</b>	<input type="checkbox"/>	<input type="checkbox"/>
<b>6</b>	<input type="checkbox"/>	<input type="checkbox"/>
<b>10</b>	<input type="checkbox"/>	<input type="checkbox"/>

## CONTACTOR SELECTION AND ORDERING

### Accessories which can be combined for withdrawable contactor - CBE and ZS1



#### Standard fittings

- operating mechanism with electrical latching
- mechanical open/closed signalling
- six pairs of open/closed signalling contacts (six break contacts plus six make contacts)
- multi-voltage feeder
- basic cabling with socket
- plug connector
- fuse-holder, with electric release device preset for installation of fuses in compliance with DIN Standards with cartridge length  $e = 442 \text{ mm}$  or BS Standards with cartridge length  $L = 553 \text{ mm}$ .  
For shorter fuses, special adaptation kits must be ordered (see accessories)
- tool for removing DIN type fuses
- mechanical release device for fuse intervention.

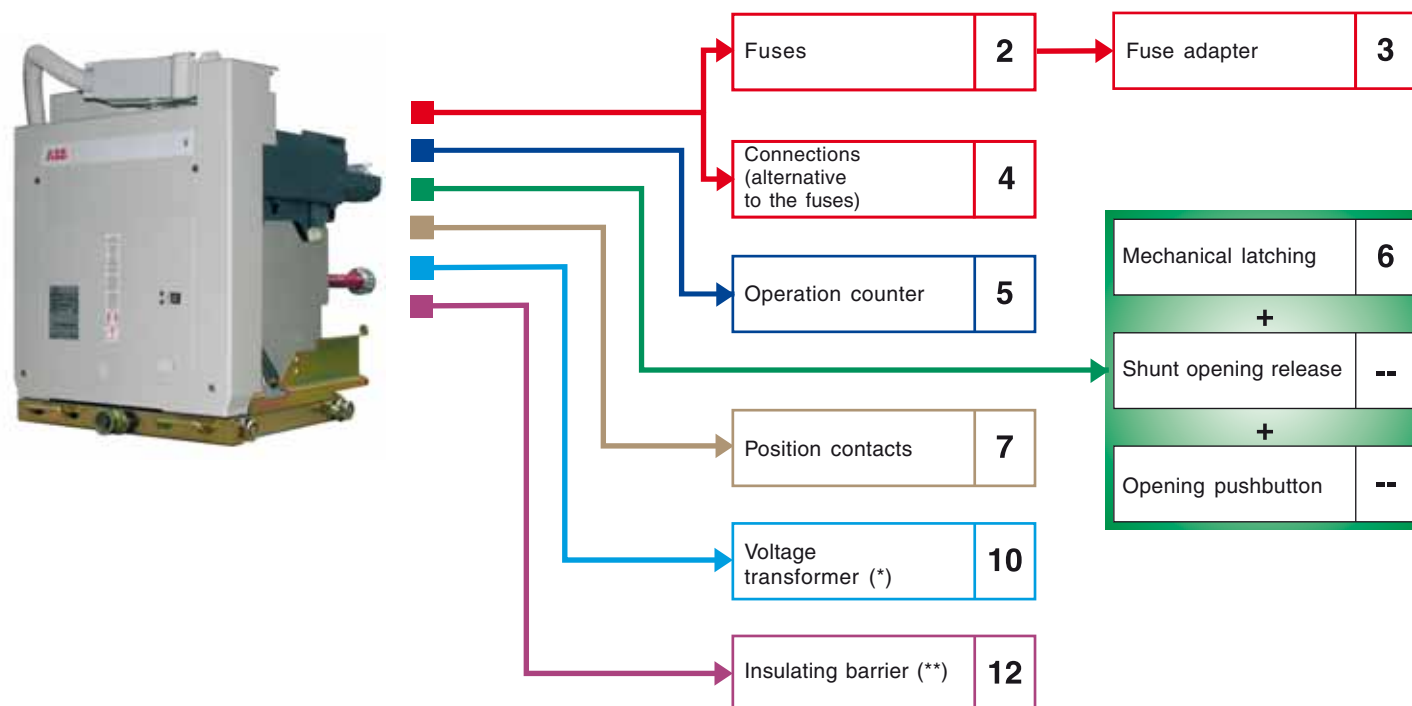
**N.B.:** the interlock between two superimposed contactors has to be make electrically. It allows the operations of the two contactors to be interlocked with each other and is suitable, for example, for use in circuits with automatic commutation.

(\*) The voltage transformer receives the power supply from the upper poles of the contactor.

#### Application of accessories

	Customer ABB	
2	■	■
3	■	■
4	■	■
5		■
6		■
7		■
8		■
9		■
10		■

### Accessories which can be combined for withdrawable contactor - UniGear ZS1 type



#### Standard fittings

- operating mechanism with electrical latching
- mechanical open/closed signalling
- six pairs of open/closed signalling contacts (six break contacts plus six make contacts)
- multi-voltage feeder
- basic cabling with socket
- plug connector
- fuse-holder, with electric release device preset for installation of fuses in compliance with DIN Standards with cartridge length **e = 442 mm** or BS Standards with cartridge length **L = 553 mm**. For shorter fuses, special adaptation kits must be ordered (see accessories)
- tool for removing DIN type fuses
- mechanical release device for fuse intervention.
- anti-racking-in lock for different rated currents. Includes the locking magnet on the truck.

#### Application of accessories

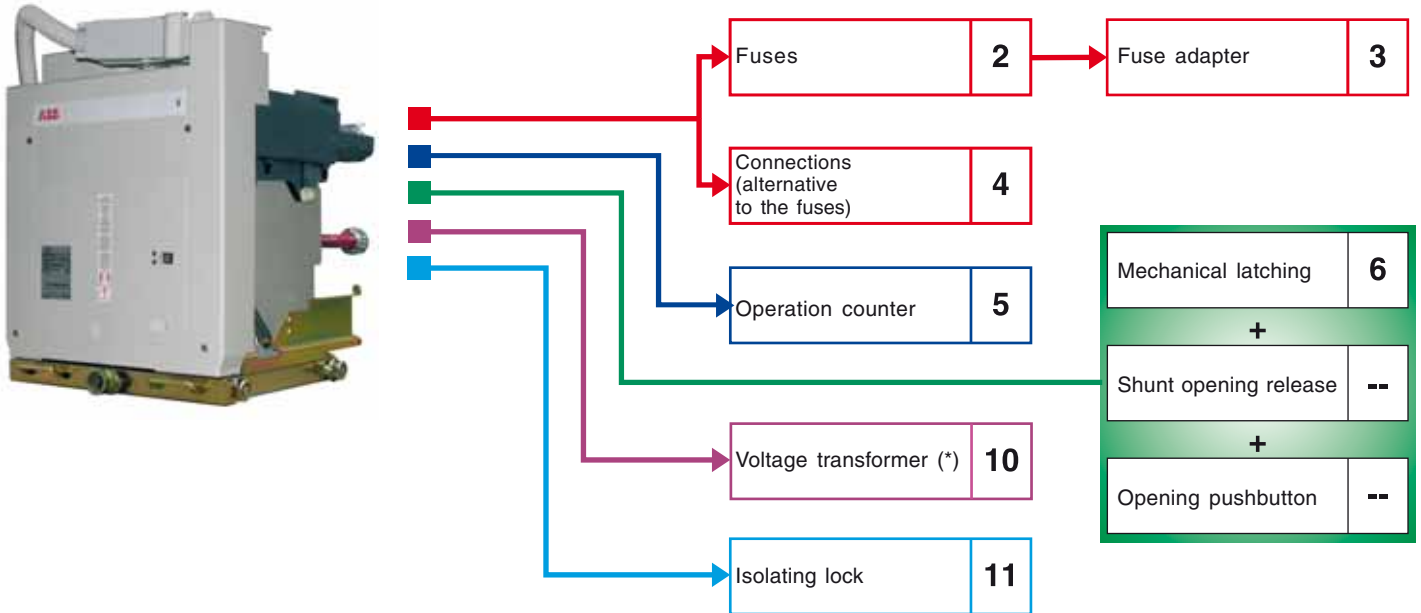
	Customer	ABB
2	■	■
3	■	■
4	■	■
5		■
6		■
7		■
10		■
12	■	

(\*) The voltage transformer receives the power supply from the upper poles of the contactor.

(\*\*) The insulating barrier is mounted in the switch-gear to guarantee the impulse withstand voltage up to 75 kV, for V12/P contactors.

## CONTACTOR SELECTION AND ORDERING

### Accessories which can be combined for withdrawable contactor - PowerCube



#### Standard fittings

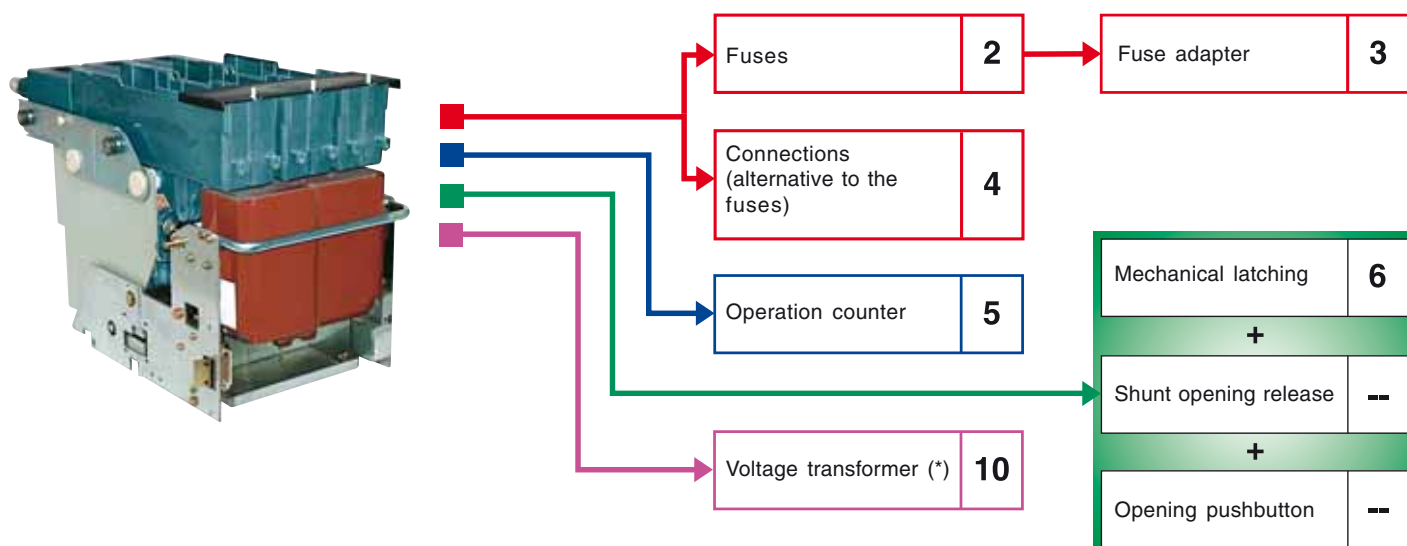
- operating mechanism with electrical latching
- mechanical open/closed signalling
- six pairs of open/closed signalling contacts (six break contacts plus six make contacts)
- multi-voltage feeder
- basic cabling with socket
- plug connector
- fuse-holder, with electric release device preset for installation of fuses in compliance with DIN Standards with cartridge length **e = 442 mm** or BS Standards with cartridge length **L = 553 mm**. For shorter fuses, special adaptation kits must be ordered (see accessories)
- tool for removing DIN type fuses
- mechanical release device for fuse intervention
- anti-racking-in lock for different rated currents. Includes the locking magnet on the truck.

#### Application of accessories

	Customer	ABB
<b>2</b>	■	■
<b>3</b>	■	■
<b>4</b>	■	■
<b>5</b>		■
<b>6</b>		■
<b>10</b>		■
<b>11</b>	■	■

(\*) The voltage transformer receives the power supply from the upper poles of the contactor.

### Accessories which can be combined for withdrawable contactor - UniMotor enclosure and switchgear



#### Standard fittings

- operating mechanism with electrical latching
- mechanical open/closed signalling
- six pairs of open/closed signalling contacts (six break contacts plus six make contacts)
- multi-voltage feeder
- plug connector
- fuse-holder, with electric release device preset for installation of fuses in compliance with DIN Standards with cartridge length **e = 442 mm** or BS Standards with cartridge length **L = 553 mm**.  
For shorter fuses, special adaptation kits must be ordered (see accessories)
- tool for removing DIN type fuses
- mechanical release device for fuse intervention.

**N.B.:** the interlock between two superimposed contactors has to be made electrically. It allows the operations of the two contactors to be interlocked with each other and is suitable, for example, for use in circuits with automatic commutation.

#### Application of accessories

	Customer ABB	
<b>2</b>	■	■
<b>3</b>	■	■
<b>4</b>	■	■
<b>5</b>		■
<b>6</b>		■
<b>10</b>		■

(\*) The voltage transformer receives the power supply from the upper poles of the contactor.

## CONTACTOR SELECTION AND ORDERING

1

### Fuse-holder for fixed contactor and electric release device for fuse intervention



This consists of a set of three supports which allow the medium voltage circuit protection fuses to be housed.

It is normally prepared for installation of fuses in compliance with DIN Standards with dimension **e = 442 mm**, or BS Standard fuses with dimension **L = 553 mm**. For shorter fuses, special adapters must be applied (see accessory 3).

The fuse-holders are always combined with the electric release device for fuse intervention.

This device makes the contactor open on intervention of one or more fuses and prevents its closure when even a single fuse is missing.

The fuses must have the dimensions and striker of average type according to DIN 43625 and BS 2692 (1975) Standards.

The electrical characteristics must comply with IEC 282-1 (1974) Standards.

#### V7; V12

Kit	Fuses	Pole centre distance	1VCF
1A	DIN	108 mm (V7)	309400R0251
1B	BS	108 mm (V7)	309400R0252
1C	DIN	150 mm (V7)	309400R0253
1D	BS	150 mm (V7)	309400R0254
1E	DIN	150 mm (V12)	309400R0255
1F	BS	150 mm (V12)	309400R0256



V-Contact in fixed version with fuse-holder.

## Fuses for power circuit

The fuses are positioned in special supports to be connected in series between the contactor and the user. The supports can house fuses in compliance with DIN or BS Standards.

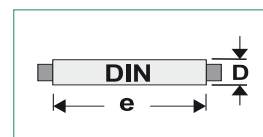
Selection of the fuses must be made according to the characteristics of the user to be protected.

For fuse selection, see “Service conditions depending on the load” - chapter 5. The tables below show the fuse ordering codes. Each code identifies a single fuse.



## ABB CMF type DIN Standard fuses for motor protection

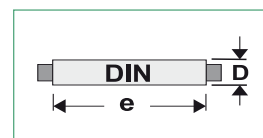
V7; V12; V7/C; V12/C; V7/Z; V12/Z; V7/P; V12/P; V7/W; V12/W; V7/UN; V12/UN						
Kit	Un [kV]	In [A]	e [mm]	Adapter	1VCF	kA (*)
2A	3.6	100	292	3B	309401R0101	50
2A	3.6	160	292	3B	309401R0102	50
2A	3.6	200	292	3B	309401R0103	50
2A	3.6	250	292	3B	309401R0104	50
2A	3.6	315	292	3B	309401R0105	50
2A	7.2	63	–	–	309401R0109	50
2A	7.2	100	–	–	309401R0111	50
2A	7.2	160	–	–	309401R0113	50
2A	7.2	200	–	–	309401R0114	50
2A	7.2	250	–	–	309401R0115	50
2A	7.2	315	–	–	309401R0116	50
2A	12	63	–	–	309401R0119	50
2A	12	100	–	–	309401R0120	50
2A	12	160	–	–	309401R0121	50
2A	12	200	–	–	309401R0122	50



(\*) Fuse breaking capacity.

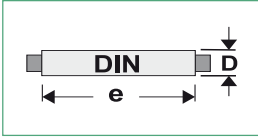
## ABB CEF type DIN Standard fuses for transformer protection

V7; V12; V7/C; V12/C; V7/Z; V12/Z; V7/P; V12/P; V7/W; V12/W; V7/UN; V12/UN						
Kit	Un [kV]	In [A]	e [mm]	Adapter	1VCF	kA (*)
2B	3.6-7.2	6	192	3A	309401R0126	50
2B	3.6-7.2	10	192	3A	309401R0127	50
2B	3.6-7.2	16	192	3A	309401R0128	50
2B	3.6-7.2	25	192	3A	309401R0129	50
2B	3.6-7.2	40	192	3A	309401R0130	50
2B	3.6-7.2	63	192	3A	309401R0131	50
2B	3.6-7.2	80	192	3A	309401R0132	50
2B	3.6-7.2	100	192	3A	309401R0133	50
2B	3.6-7.2	125	292	3B	309401R0134	50



(\*) Fuse breaking capacity.

## CONTACTOR SELECTION AND ORDERING

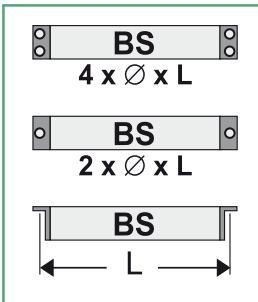


### V7; V12; V7/C; V12/C; V7/Z; V12/Z; V7/P; V12/P; V7/W; V12/W; V7/UN; V12/UN

Kit	Un [kV]	In [A]	e [mm]	Adapter	1VCF	kA (*)
2B	3.6-7.2	160	292	3B	309401R0135	50
2B	3.6-7.2	200	292	3B	309401R0136	50
2B	12	6	292	3B	309401R0137	50
2B	12	10	292	3B	309401R0138	50
2B	12	16	292	3B	309401R0139	50
2B	12	25	292	3B	309401R0140	50
2B	12	40	292	3B	309401R0141	50
2B	12	63	292	3B	309401R0142	50
2B	12	80	292	3B	309401R0143	50
2B	12	100	292	3B	309401R0144	50
2B	12	125	–	–	309401R0145	50
2B	12	160	–	–	309401R0146	50
2B	12	200	–	–	309401R0147	50

(\*) Fuse breaking capacity.

### GEC type BS Standard fuses for motor protection <sup>(1)</sup>



### V7; V12; V7/C; V12/C; V7/Z; V12/Z; V7/P; V12/P; V7/W; V12/W; V7/UN; V12/UN

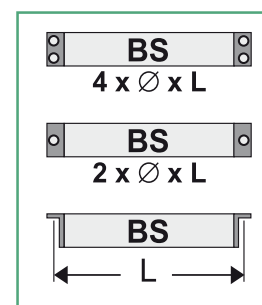
Kit	Fuse	Un [kV]	In [A]	n x Ø x L [mm]	Adapter	1VCF	kA (*)
2C	K81PEX	3.6	100	4 x 10 x 305	3D	309401R0201	40
2C	K81PEX	3.6	125	4 x 10 x 305	3D	309401R0202	40
2C	K81PEX	3.6	160	4 x 10 x 305	3D	309401R0203	40
2C	K81PEX	3.6	200	4 x 10 x 305	3D	309401R0204	40
2C	K81PEX	3.6	250	4 x 10 x 305	3D	309401R0205	40
2C	K81PEX	3.6	315	4 x 10 x 305	3D	309401R0206	40
2C	K81SDX	7.2	50	4 x 10 x 454	3F	309401R0223	45
2C	K81SDX	7.2	63	4 x 10 x 454	3F	309401R0224	45
2C	K81SDX	7.2	80	4 x 10 x 454	3F	309401R0225	45
2C	K81SDX	7.2	100	4 x 10 x 454	3F	309401R0226	45
2C	K81SDX	7.2	125	4 x 10 x 454	3F	309401R0227	45
2C	K81SDX	7.2	160	4 x 10 x 454	3F	309401R0228	45
2C	K81SDX	7.2	200	4 x 10 x 454	3F	309401R0229	45
2C	K81SDX	7.2	225	4 x 10 x 454	3F	309401R0230	45
2C	K81SDX	7.2	250	4 x 10 x 454	3F	309401R0231	45
2C	K81SDX	7.2	280	4 x 10 x 454	3F	309401R0232	45
2C	K81SDX	7.2	315	4 x 10 x 454	3F	309401R0233	45

(1) **ATTENTION!** The ABB CMF fuses in compliance with BS Standards cannot be installed.

(\*) Fuse breaking capacity.

Bussman type BS Standard fuses for motor/capacitor bank protection <sup>(2)</sup>

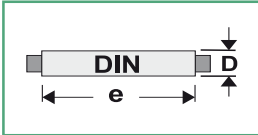
V7; V12; V7/C; V12/C; V7/Z; V12/Z; V7/P; V12/P; V7/W; V12/W; V7/UN; V12/UN							
Kit	Fuse	Un [kV]	In [A]	n x Ø x L [mm]	Adapter	1VCF	kA (*)
2D	WDFHO	3.6	50	4 x 10 x 305	3D	309401R0401	50
2D	WDFHO	3.6	63	4 x 10 x 305	3D	309401R0402	50
2D	WDFHO	3.6	80	4 x 10 x 305	3D	309401R0403	50
2D	WDFHO	3.6	100	4 x 10 x 305	3D	309401R0404	50
2D	WDFHO	3.6	125	4 x 10 x 305	3D	309401R0405	50
2D	WFFHO	3.6	160	4 x 10 x 305	3D	309401R0406	50
2D	WFFHO	3.6	200	4 x 10 x 305	3D	309401R0407	50
2D	WKFHO	3.6	250	4 x 10 x 305	3D	309401R0408	50
2D	WKFHO	3.6	315	4 x 10 x 305	3D	309401R0409	50
2D	WKFHO	3.6	355 <sup>(1)</sup>	4 x 10 x 305	3D	309401R0410	50
2D	WKFHO	3.6	400 <sup>(1)</sup>	4 x 10 x 305	3D	309401R0411	50
2D	WFGHO	3.6	31,5	4 x 10 x 410	3E	309401R0412	50
2D	WFGHO	3.6	40	4 x 10 x 410	3E	309401R0413	50
2D	WFGHO	3.6	50	4 x 10 x 410	3E	309401R0414	50
2D	WFGHO	3.6	63	4 x 10 x 410	3E	309401R0415	50
2D	WFGHO	3.6	80	4 x 10 x 410	3E	309401R0416	50
2D	WFGHO	3.6	100	4 x 10 x 410	3E	309401R0417	50
2D	WFGHO	3.6	125	4 x 10 x 410	3E	309401R0418	50
2D	WFGHO	3.6	160	4 x 10 x 410	3E	309401R0419	50
2D	WFGHO	3.6	200	4 x 10 x 410	3E	309401R0420	50
2D	WFGHO	3.6	250	4 x 10 x 410	3E	309401R0421	50
2D	WKGHO	3.6	315	4 x 10 x 410	3E	309401R0422	50
2D	WKGHO	3.6	355 <sup>(1)</sup>	4 x 10 x 410	3E	309401R0423	50
2D	WKGHO	3.6	400 <sup>(1)</sup>	4 x 10 x 410	3E	309401R0424	50
2D	WKGHO	3.6	450 <sup>(1)</sup>	4 x 10 x 410	3E	309401R0425	50
2D	WFNHO	7.2	25	4 x 10 x 454	3F	309401R0426	40
2D	WFNHO	7.2	31,5	4 x 10 x 454	3F	309401R0427	40
2D	WFNHO	7.2	40	4 x 10 x 454	3F	309401R0428	40
2D	WFNHO	7.2	50	4 x 10 x 454	3F	309401R0429	40
2D	WFNHO	7.2	63	4 x 10 x 454	3F	309401R0430	40
2D	WFNHO	7.2	80	4 x 10 x 454	3F	309401R0431	40
2D	WFNHO	7.2	100	4 x 10 x 454	3F	309401R0432	40
2D	WFNHO	7.2	125	4 x 10 x 454	3F	309401R0433	40
2D	WFNHO	7.2	160	4 x 10 x 454	3F	309401R0434	40
2D	WKNHO	7.2	200	4 x 10 x 454	3F	309401R0435	40
2D	WKNHO	7.2	224	4 x 10 x 454	3F	309401R0436	40
2D	WKNHO	7.2	250	4 x 10 x 454	3F	309401R0437	40
2D	WKNHO	7.2	315	4 x 10 x 454	3F	309401R0438	40



- (1) For capacitor bank application only.  
 (2) CAUTION! The ABB CMF fuses according to BS Standards cannot be installed  
 (\*) Fuse breaking capacity.

## CONTACTOR SELECTION AND ORDERING

### SIBA type DIN Standard fuses for motor/capacitor bank protection

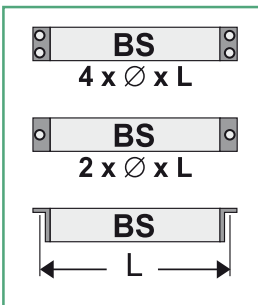


#### V7; V12; V7/C; V12/C; V7/Z; V12/Z; V7/W; V12/W; V7/P; V12/P; V7/UN; V12/UN

Kit	Fuse	Un [kV]	In [A]	e [mm]	Adapter	SIBA Code	kA (*)
2E	DIN-MCA	3.6	50	292	3B	3020153.50	50
2E	DIN-MCA	3.6	63	292	3B	3020153.63	50
2E	DIN-MCA	3.6	80	292	3B	3020153.80	50
2E	DIN-MCA	3..6	100	292	3B	3020153.100	50
2E	DIN-MCA	3.6	125	292	3B	3020153.125	50
2E	DIN-MCA	3.6	160	292	3B	3020153.160	50
2E	DIN-MCA	3.6	200	292	3B	3020153.200	50
2E	DIN-MCA	3.6	225	292	3B	3020054.224	50
2E	DIN-MCA	3.6	250	292	3B	3020054.250	50
2E	DIN-MCA	3.6	315	292	3B	3010054.315	50
2E	DIN-MCA	7.2	50	442	-	3010853.50	50
2E	DIN-MCA	7.2	63	442	-	3010853.63	50
2E	DIN-MCA	7.2	80	442	-	3010853.80	50
2E	DIN-MCA	7.2	100	442	-	3010853.100	50
2E	DIN-MCA	7.2	125	442	-	3010953.125	50
2E	DIN-MCA	7.2	160	442	-	3010953.160	50
2E	DIN-MCA	7.2	200	442	-	3011054.200	50
2E	DIN-MCA	7.2	225	442	-	3011054.224	50
2E	DIN-MCA	7.2	250	442	-	3011054.250	50
2E	DIN-MCA	7.2	315	442	-	3011054.315	50

(\*) Fuse breaking capacity.

### SIBA type BS Standard fuses for motor/capacitor bank protection



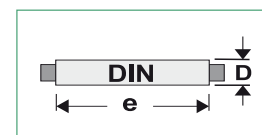
#### V7; V12; V7/C; V12/C; V7/Z; V12/Z; V7/W; V12/W; V7/P; V12/P; V7/UN; V12/UN

Kit	Fuse	Un [kV]	In [A]	n x Ø x L [mm]	Adapter	SIBA Code	kA (*)
2F	BS-MCA	3.6	50	2 x 8 x 235	3C	3026956.50	50
2F	BS-MCA	3.6	63	2 x 8 x 235	3C	3026956.63	50
2F	BS-MCA	3.6	80	2 x 8 x 235	3C	3026956.80	50
2F	BS-MCA	3.6	100	2 x 8 x 235	3C	3026956.100	50
2F	BS-MCA	3.6	125	2 x 8 x 235	3C	3026956.125	50
2F	BS-MCA	3.6	160	2 x 8 x 235	3C	3026956.160	50
2F	BS-MCA	3.6	200	2 x 8 x 235	3C	3026956.200	50
2F	BS-MCA	3.6	225	2 x 8 x 235	3C	3026956.224	50
2F	BS-MCA	3.6	250	2 x 8 x 235	3C	3026956.250	50
2F	BS-MCA	3.6	315	2 x 8 x 235	3C	3026956.315	50
2F	BS-MCA	7.2	50	4 x 10 x 454	3F	3027156.50	50
2F	BS-MCA	7.2	63	4 x 10 x 454	3F	3027156.63	50
2F	BS-MCA	7.2	80	4 x 10 x 454	3F	3027156.80	50
2F	BS-MCA	7.2	100	4 x 10 x 454	3F	3027156.100	50
2F	BS-MCA	7.2	125	4 x 10 x 454	3F	3027156.125	50
2F	BS-MCA	7.2	160	4 x 10 x 454	3F	3027156.160	50
2F	BS-MCA	7.2	200	4 x 10 x 454	3F	3027156.200	50
2F	BS-MCA	7.2	225	4 x 10 x 454	3F	3027156.224	50
2F	BS-MCA	7.2	250	4 x 10 x 454	3F	3027156.250	50
2F	BS-MCA	7.2	315	4 x 10 x 454	3F	3027156.315	50

(\*) Fuse breaking capacity.

## Bussman type DIN Standard fuses for motor/capacitor bank protection

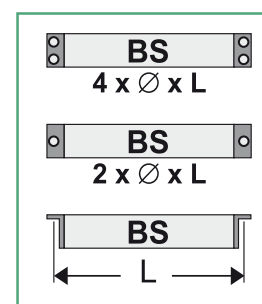
V7; V12; V7/C; V12/C; V7/Z; V12/Z; V7/W; V12/W; V7/P; V12/P; V7/UN; V12/UN							
Kit	Fuse	Un [kV]	In [A]	e [mm]	Adapter	1VCF	kA (*)
2G	WDLSJ	3.6	50	292	3B	309401R0301	50
2G	WDLSJ	3.6	63	292	3B	3094013R002	50
2G	WDLSJ	3.6	80	292	3B	3094013R003	50
2G	WDLSJ	3.6	100	292	3B	3094013R004	50
2G	WDLSJ	3.6	125	292	3B	3094013R005	50
2G	WFLSJ	3.6	160	292	3B	3094013R006	50
2G	WFLSJ	3.6	200	292	3B	3094013R007	50
2G	WKLSJ	3.6	250	292	3B	3094013R008	50
2G	WKLSJ	3.6	315	292	3B	3094013R009	50
2G	WKLSJ	3.6	400 <sup>(1)</sup>	292	3B	3094013R010	50
2G	WFMSJ	7.2	25	-	-	3094013R011	40
2G	WFMSJ	7.2	31.5	-	-	3094013R012	40
2G	WFMSJ	7.2	40	-	-	3094013R013	40
2G	WFMSJ	7.2	50	-	-	3094013R014	40
2G	WFMSJ	7.2	63	-	-	3094013R015	40
2G	WFMSJ	7.2	80	-	-	3094013R016	40
2G	WFMSJ	7.2	100	-	-	3094013R017	40
2G	WFMSJ	7.2	125	-	-	3094013R018	40
2G	WFMSJ	7.2	160	-	-	3094013R019	40
2G	WKMSJ	7.2	200	-	-	3094013R020	40
2G	WKMSJ	7.2	224	-	-	3094013R021	40
2G	WKMSJ	7.2	250	-	-	3094013R022	40
2G	WKMSJ	7.2	315	-	-	3094013R023	40
2G	WKMSJ	7.2	355 <sup>(1)</sup>	-	-	3094013R024	40



(\*) Fuse breaking capacity.  
(1) For capacitor bank application only.

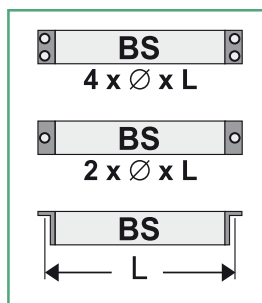
## Bussman type BS Standard fuses for transformer protection

V7; V12; V7/C; V12/C; V7/Z; V12/Z; V7/W; V12/W; V7/P; V12/P; V7/UN; V12/UN							
Kit	Fuse	Un [kV]	In [A]	n x Ø x L [mm]	Adapter	1VCF	kA (*)
2H	BDGHO	7.2	6.3	4 x 10 x 410	3E	3094014R051	40
2H	BDGHO	7.2	10	4 x 10 x 410	3E	3094014R052	40
2H	BDGHO	7.2	16	4 x 10 x 410	3E	3094014R053	40
2H	BDGHO	7.2	20	4 x 10 x 410	3E	3094014R054	40
2H	BDGHO	7.2	25	4 x 10 x 410	3E	3094014R055	40
2H	BDGHO	7.2	31.5	4 x 10 x 410	3E	3094014R056	40
2H	BDGHO	7.2	40	4 x 10 x 410	3E	3094014R057	40
2H	BDGHO	7.2	50	4 x 10 x 410	3E	3094014R058	40
2H	BDGHO	7.2	63	4 x 10 x 410	3E	3094014R059	40
2H	BDGHO	7.2	80	4 x 10 x 410	3E	3094014R060	40
2H	BFGHO	7.2	90	4 x 10 x 410	3E	3094014R061	40
2H	BFGHO	7.2	100	4 x 10 x 410	3E	3094014R062	40
2H	BFGHO	7.2	125	4 x 10 x 410	3E	3094014R063	40
2H	BFGHO	7.2	140	4 x 10 x 410	3E	3094014R064	40
2H	BFGHO	7.2	160	4 x 10 x 410	3E	3094014R065	40



(\*) Fuse breaking capacity.

## CONTACTOR SELECTION AND ORDERING

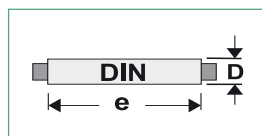


### V7; V12; V7/C; V12/C; V7/Z; V12/Z; V7/W; V12/W; V7/P; V12/P; V7/UN; V12/UN

Kit	Fuse	Un [kV]	In [A]	n x Ø x L [mm]	Adapter	1VCF	kA (*)
2I	BDGHO	12	6.3	4 x 10 x 410	3E	309401R0466	40
2I	BDGHO	12	10	4 x 10 x 410	3E	309401R0467	40
2I	BDGHO	12	16	4 x 10 x 410	3E	309401R0468	40
2I	BDGHO	12	20	4 x 10 x 410	3E	309401R0469	40
2I	BDGHO	12	22.4	4 x 10 x 410	3E	309401R0470	40
2I	BDGHO	12	25	4 x 10 x 410	3E	309401R0471	40
2I	BDGHO	12	31.5	4 x 10 x 410	3E	309401R0472	40
2I	BDGHO	12	35.5	4 x 10 x 410	3E	309401R0473	40
2I	BDGHO	12	40	4 x 10 x 410	3E	309401R0474	40
2I	BDGHO	12	45	4 x 10 x 410	3E	309401R0475	40
2I	BDGHO	12	50	4 x 10 x 410	3E	309401R0476	40
2I	BFGHO	12	56	4 x 10 x 410	3E	309401R0477	40
2I	BFGHO	12	63	4 x 10 x 410	3E	309401R0478	40
2I	BFGHO	12	71	4 x 10 x 410	3E	309401R0479	40
2I	BFGHO	12	80	4 x 10 x 410	3E	309401R0480	40
2I	BFGHO	12	90	4 x 10 x 410	3E	309401R0481	40
2I	BFGHO	12	100	4 x 10 x 410	3E	309401R0482	40

(\*) Fuse breaking capacity.

### Bussman type DIN Standard fuses for transformer protection



### V7; V12; V12/C; V7/C; V7/Z; V12/Z; V7/W; V12/W; V7/P; V12/P; V7/UN; V12/UN

Kit	Fuse	Un [kV]	In [A]	e [mm]	Adapter	1VCP	kA (*)
2K	SDLSJ	7.2	6.3	292	3B	309401R0350	50
2K	SDLSJ	7.2	10	292	3B	309401R0351	50
2K	SDLSJ	7.2	16	292	3B	309401R0352	50
2K	SDLSJ	7.2	20	292	3B	309401R0353	50
2K	SDLSJ	7.2	25	292	3B	309401R0354	50
2K	SDLSJ	7.2	31.5	292	3B	309401R0355	50
2K	SDLSJ	7.2	40	292	3B	309401R0356	50
2K	SDLSJ	7.2	50	292	3B	309401R0357	50
2K	SDLSJ	7.2	63	292	3B	309401R0358	50
2K	SFLSJ	7.2	80	292	3B	309401R0359	40
2K	SFLSJ	7.2	100	292	3B	309401R0360	40
2K	SFLSJ	7.2	125	292	3B	309401R0361	40
2K	SFLSJ	7.2	160	292	3B	309401R0362	40
2K	SDLSJ	12	6.3	292	3B	309401R0363	50
2K	SDLSJ	12	10	292	3B	309401R0364	50
2K	SDLSJ	12	16	292	3B	309401R0365	50
2K	SDLSJ	12	20	292	3B	309401R0366	50
2K	SDLSJ	12	25	292	3B	309401R0367	50
2K	SDLSJ	12	31.5	292	3B	309401R0368	50
2K	SDLSJ	12	40	292	3B	309401R0369	50
2K	SDLSJ	12	50	292	3B	309401R0370	50
2K	SDLSJ	12	63	292	3B	309401R0371	50
2K	SFLSJ	12	80	292	3B	309401R0372	50
2K	SFLSJ	12	100	292	3B	309401R0373	50
2K	SKLSJ	12	125	292	3B	309401R0374	50

(\*) Fuse breaking capacity.

## Adapter for fuse application

The kit includes all the accessories required to adapt and mount three fuses (in compliance with DIN Standards with dimension “e” less than 442 mm; in compliance with BS Standards with dimension L less than 553 mm). The kit can be installed directly onto the fuse-holder supports. The fuses must have the dimensions and striker of average type according to DIN 43625 and BS 2692 (1975) Standards. The electrical characteristics must comply with IEC 282-1 (1974) Standards. For fuse selection, see “Service conditions depending on the load” - chapter 5.

The adaptation kits are available in the following types:

- 3A** For fuses complying with DIN Standards with dimension  $e = 192$  mm;
- 3B** For fuses complying with DIN Standards with dimension  $e = 292$  mm;
- 3C** For fuses complying with BS Standards ( $2 \times 8 \times L = 235$  mm);
- 3D** For fuses complying with BS Standards ( $4 \times 10 \times L = 305$  mm);
- 3E** For fuses complying with BS Standards ( $4 \times 10 \times L = 410$  mm).
- 3F** For fuses complying with BS Standards with dimension  $L = 454$  mm

V7; V12; V7/C; V12/C; V7/Z; V12/Z; V7/P; V12/P; V7/W; V12/W; V7/UN; V12/UN

Kit	Standards	e [mm]	L [mm]	1VCF
3A	DIN	192	-	309402R0001
3B	DIN	292	-	309402R0002
3C	BS	-	2 x 8 x 235	309402R0003
3D	BS	-	4 x 10 x 305	309402R0004
3E	BS	-	4 x 10 x 410	309402R0006
3F	BS	-	4 x 10 x 454	309402R0005

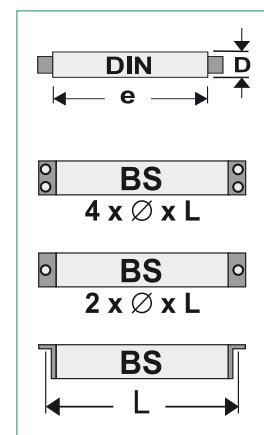
## Connections alternative to fuses

The kit includes three flat copper bars and fixing screws to be installed when the fuses are not required. The kit can be installed directly onto the fuse-holder supports.

V7; V12; V7/C; V12/C; V7/Z; V12/Z; V7/P; V12/P; V7/W; V12/W; V7/UN; V12/UN

Kit	1VCF
4A	309400R0211

3



4



## CONTACTOR SELECTION AND ORDERING

5

### Operation counter



This is an impulse counting device which counts the contactor closing cycles.

#### V7; V12

Kit	Power supply voltage	1VCF
5A	(24 ... 60 V –)	309400R0311
5B	(100 ... 250 V – / ~)	309400R0312

#### V7/C; V12/C; V7/Z; V12/Z; V7/P; V12/P; V7/W; V12/W

Kit	Power supply voltage	1VCF
5A	(24 ... 60 V –)	309400R0321
5B	(100 ... 250 V – / ~)	309400R0322

#### V7/UN; V12/UN

Kit	Power supply voltage	1VCF
5A	(24 ... 60 V –)	309400R0331
5B	(100 ... 250 V – / ~)	309400R0342

6

### Mechanical latching



This is a mechanical device which, on closure of the contactor, latches the moving equipment and keeps the contactor closed with the operating mechanism coils de-energised. The mechanical latching device includes the shunt opening release for instantaneous service, the opening pushbutton and the release device for fuse intervention. Selection of the mechanical latching device is made according to the voltage of the shunt opening release and the power supply voltage of the contactor as listed below. The current absorbed by the shunt opening release has a maximum value of 7A for 70 ms.

#### V7; V12; V7/C; V12/C; V7/Z; V12/Z; V7/P; V12/P; V7/W; V12/W; V7/UN; V12/UN

Kit	Un	1VCF
6	24 V –	309401R0902
6	30 V –	309401R0903
6	48 V –	309401R0904
6	60 V –	309401R0905
6	110 V –	309401R0909
6	120 V –	309401R0911
6	125 V –	309401R0912
6	127 V –	309401R0913
6	130 V –	309401R0914
6	220 V –	309401R0918
6	250 V –	309401R0922
6	110 V ~ (50 Hz)	309401R0939
6	120 V ~ (50 Hz)	309401R0940
6	220 V ~ (50 Hz)	309401R0948
6	230 V ~ (50 Hz)	309401R0950
6	240 V ~ (50 Hz)	309401R0951
6	110 V ~ (60 Hz)	309401R0969
6	120 V ~ (60 Hz)	309401R0971
6	220 V ~ (60 Hz)	309401R0978
6	230 V ~ (60 Hz)	309401R0980
6	240 V ~ (60 Hz)	309401R0981

### Connected/isolated position contacts on withdrawable truck

These signal the position of the contactor truck inside the CBE enclosure. The kit includes a set of 10 auxiliary contacts. This accessory must always be requested for contactors to be used in ZS1 and UniGear ZS1 type switchgear.

**7A** Standard diagram

**7B** Calor Emag diagram.

#### Electrical characteristics of the contact

Un	Icu	cosφ	T
220 V~	10 A	0.4	–
220 V~	5 A	0.4	–
220 V–	1 A	–	10 ms

**V7/C; V12/C; V7/Z; V12/Z; V7/P;  
V12/P; V7/W; V12/W**

Kit	1VCP
<b>7A</b>	<b>309400R0241</b>
<b>7B</b>	<b>309400R0242</b>



7

### Locking magnet in the withdrawable truck

This only allows the withdrawable contactor to be racked in or out of the enclosure when the electromagnet is energised and the contactor open.

This accessory is compulsory for V/W UniSafe and V/P (UniGear type ZS1) contactors because it is an integral part of the anti-racking-in lock.

**V7/C; V12/C; V7/Z; V12/Z; V7/P;  
V12/P; V7/W; V12/W**

Kit	Un	F	1VCP
<b>8</b>	<b>24 V –</b>	<b>-</b>	<b>309402R0902</b>
<b>8</b>	<b>30 V –</b>	<b>-</b>	<b>309402R0903</b>
<b>8</b>	<b>48 V –</b>	<b>-</b>	<b>309402R0904</b>
<b>8</b>	<b>60 V –</b>	<b>-</b>	<b>309402R0905</b>
<b>8</b>	<b>110 V –</b>	<b>-</b>	<b>309402R0909</b>
<b>8</b>	<b>125 V –</b>	<b>-</b>	<b>309402R0912</b>
<b>8</b>	<b>220 V –</b>	<b>-</b>	<b>309402R0918</b>
<b>8</b>	<b>24 V ~</b>	<b>50 Hz</b>	<b>359618R0932</b>
<b>8</b>	<b>48 V ~</b>	<b>50 Hz</b>	<b>359618R0934</b>
<b>8</b>	<b>60 V ~</b>	<b>50 Hz</b>	<b>359618R0935</b>
<b>8</b>	<b>110 V ~</b>	<b>50 Hz</b>	<b>359618R0939</b>
<b>8</b>	<b>120 V ~</b>	<b>50 Hz</b>	<b>359618R0941</b>
<b>8</b>	<b>127 V ~</b>	<b>50 Hz</b>	<b>359618R0943</b>
<b>8</b>	<b>220 V ~</b>	<b>50 Hz</b>	<b>359618R0948</b>
<b>8</b>	<b>230 V ~</b>	<b>50 Hz</b>	<b>359618R0950</b>
<b>8</b>	<b>240 V ~</b>	<b>50 Hz</b>	<b>359618R0951</b>
<b>8</b>	<b>110 V ~</b>	<b>60 Hz</b>	<b>359618R0969</b>
<b>8</b>	<b>120 V ~</b>	<b>60 Hz</b>	<b>359618R0971</b>
<b>8</b>	<b>127 V ~</b>	<b>60 Hz</b>	<b>359618R0973</b>
<b>8</b>	<b>220 V ~</b>	<b>60 Hz</b>	<b>359618R0978</b>
<b>8</b>	<b>230 V ~</b>	<b>60 Hz</b>	<b>359618R0980</b>
<b>8</b>	<b>240 V ~</b>	<b>60 Hz</b>	<b>359618R0981</b>



8

## CONTACTOR SELECTION AND ORDERING

9

### Application of mechanical interlock with the enclosure door



This only allows the door of the switchgear to be opened when the contactor is in the isolated position. This accessory can only be installed if the contactor is used in UniVer C type switchgear or CBE enclosures.

#### V7/C; V12/C

Kit	1VCF
9	359600R0381

10

### Voltage transformer on board



A single-phase voltage transformer complete with relative protection fuses incorporated in the resin of the transformer itself can be mounted on board. The voltage transformer must be used to supply the operating mechanism coils of the contactor. Only combination with type 2 feeder is foreseen.

Apart from the contactor power supply, it is possible to supply other components in the compartment (signalling lamps, auxiliary relays and protection relays up to a maximum power of 50 VA.) Its use as an instrument transformer for an undervoltage protection relay and to supply several contactors (e.g.: star-delta starting) is not foreseen.

Kit	Type	Un [V]	Thermal power	1VCF
<b>V7; V12 (with fuse-holder - pole centre distance 150 mm)</b>				
10A	TV - 3,6	3300/110	250 VA	309400R0351
10A	TV - 7,2	6000/110	250 VA	309400R0352
10A	TV - 12	10000/110	250 VA	309400R0353
10A	TV - 3,6	3300/220	250 VA	309400R0354
10A	TV - 7,2	6000/220	250 VA	309400R0355
10A	TV - 12	10000/220	250 VA	309400R0356

Kit	Type	Un [V]	Thermal power	1VCF
<b>V7/C; V12/C; V7/Z; V12/Z; V7/P; V12/P; V7/W; V12/W</b>				
10B	TV - 3.6	3300/110	250 VA	309400R0357
10B	TV - 7,2	6000/110	250 VA	309400R0358
10B	TV - 12	10000/110	250 VA	309400R0359
10B	TV - 3.6	3300/220	250 VA	309400R0360
10B	TV - 7.2	6000/220	250 VA	309400R0361
10B	TV - 12	10000/220	250 VA	309400R0362
<b>V7/UN; V12/UN</b>				
10C	TV - 3.6	3300/110	250 VA	309400R0363
10C	TV - 7.2	6000/110	250 VA	309400R0364
10C	TV - 12	10000/110	250 VA	309400R0365
10C	TV - 3.6	3300/220	250 VA	309400R0366
10C	TV - 7.2	6000/220	250 VA	309400R0367
10C	TV - 12	10000/220	250 VA	309400R0368

### Rack-in lock

Isolation lock for PowerCube units. It prevents isolation of the apparatus if the unit door is open. This lock only operates if the PB1 unit is also fitted with the corresponding lock.

#### V7/W; V12/W; V7/P; V12/P

Kit	1VCF
11	349700R0047

11



### Insulating barrier

The insulating barrier is mounted in the UniGear ZS1 type switchgear to guarantee the impulse withstand voltage up to 75 kV (BIL) for 12 kV contactors.

#### V12/P

Kit	1VCF
12	309400R0531

12






## UNIMOTOR ENCLOSURE SELECTION AND ORDERING

General characteristics	32
Standard fittings	32
Enclosure ordering codes	33
Accessory ordering codes	34

## UNIMOTOR ENCLOSURE SELECTION AND ORDERING

### General characteristics

Enclosure		UniMotor	
Standards	IEC 62271-100	■	
	CEI 17-1 (file 1375)/17-6 (file 2056)	■	
	CENELEC HD 348 56 / 187 55	■	
Rated voltage	U [kV]	12	
Rated insulation voltage	Ui [kV]	12	
Withstand voltage at 50 Hz	U (1 min) [kV]	28	
Impulse withstand voltage	Uw [kV]	75 <sup>(1)</sup>	
Rated frequency	F [Hz]	50-60	
Rated current (40 °C)	In [A]	400 <sup>(2)</sup>	
Rated short-time withstand current	Icw [kA]	50	
Overall dimensions (excluding monoblocs)		H [mm]	670
		L [mm]	500
		D [mm]	880
Weight (with CT)	[kg]	120	
Tropicalisation	IEC 721-2-1	■	
Electromagnetic compatibility	EN 50081.../50082...	■	
Degree of protection with door closed	IP	3X	
Enclosure codes	Page	39	
Accessories	Page	40	

(1) As far as the upper metal shutter closed with the contactor truck racked out.

(2) Without current transformers, without fuses and with degree of protection IP3X. For other conditions, please contact us.

### Standard fittings

The basic coded versions of UniMotor enclosures are always provided with IP3X degree of protection with the door closed, and IP2X with the door open and are made up as follows:

- structure made of unpainted galvanised sheet
- insulating monoblocs with input terminals
- sliding earthing contact
- connector for auxiliary circuits
- isolation unit for operation with door closed with handle without key

- translation guides and metallic shutter for the upper contacts
- manual opening (only for contactor with mechanical latching).
- door painted RAL 7035. On request, it is possible to supply the door dismantled and protected against corrosion (painting to be done by the customer) with a kit of accessories (hinges, inspection window, handle, etc.).

## Enclosure ordering codes

### UniMotor (1)

Contactor with electrical latching		Enclosure without current transformers			
U [kV]	In [A]	Mounted door - painted RAL 7035		Mounted door - Galvanized	
		UXAB		UXAB	
V7/UN	7	400	303141211	303141411	
V12/UN	12	400	303142211	303142411	

Contactor with electrical latching		Enclosure preset for current transformers <sup>(1)</sup>			
U [kV]	In [A]	Mounted door - painted RAL 7035		Mounted door - Galvanized	
		UXAB		UXAB	
V7/UN	7	400	303141212	303141412	
V12/UN	12	400	303142212	303142412	

Contactor with mechanical latching		Enclosure without current transformers			
U [kV]	In [A]	Mounted door - painted RAL 7035		Mounted door - Galvanized	
		UXAB		UXAB	
V7/UN	7	400	303141221	303141421	
V12/UN	12	400	303142221	303142421	

Contactor with mechanical latching		Enclosure preset for current transformers <sup>(1)</sup>			
U [kV]	In [A]	Mounted door - painted RAL 7035		Mounted door - Galvanized	
		UXAB		UXAB	
V7/UN	7	400	303141222	303141422	
V12/UN	12	400	303142222	303142422	



Operating instruction plate <sup>(2)</sup>	
Language	UXAB
Italian	309300101
English	309300102
German	309300103
French	309300104

(1) Complete with current transformers (see accessories on page 34).

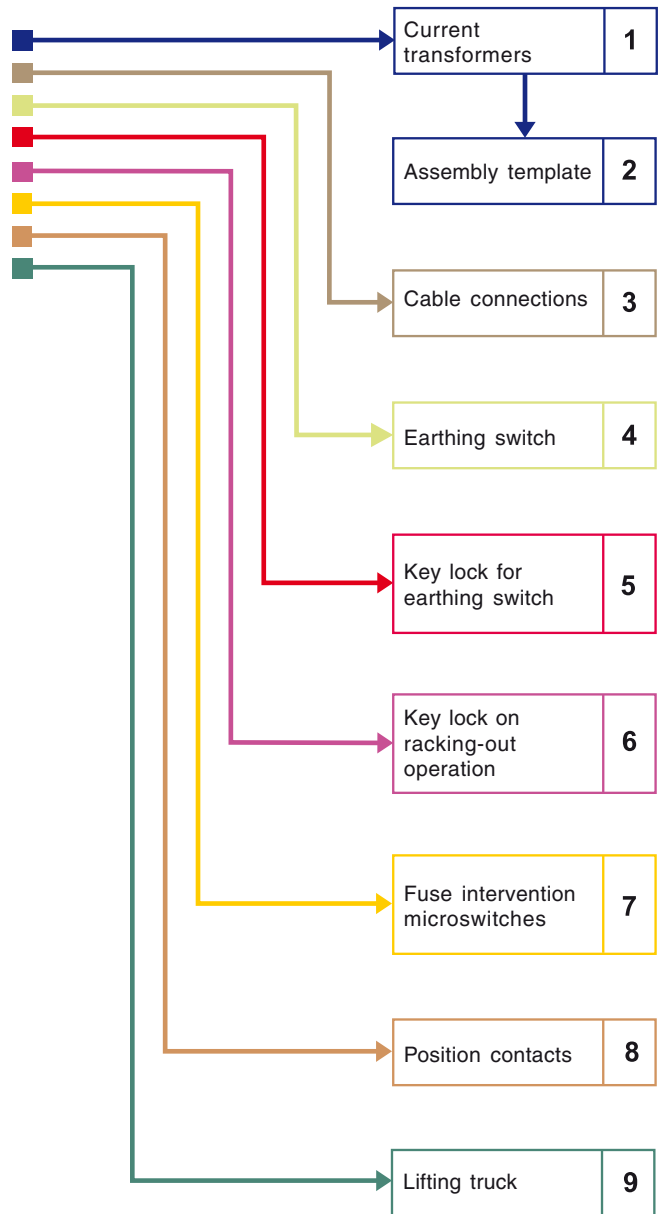
(2) When ordering, it is necessary to specify the language of the operating instruction plate.

# UNIMOTOR ENCLOSURE SELECTION AND ORDERING

## Accessory ordering codes

### Possible combinations of enclosure accessories

All the accessories indicated in the diagram below are compatible with each other.



Application of accessories		
	Customer	ABB
1	■	■
2	■	■
3	■	■
4	■	■
5	■	■
6		■
7		■
8		■

## 1

## Current transformers



Three-phase current transformers embedded in a resin monobloc are available for the UniMotor enclosure. The monobloc is always three-pole and complete with terminals for cable connection.

The monobloc can house the primary and secondary circuits relative to two or three phases. Selection of the monobloc with the current transformers depends on the primary current, the number of phases to be controlled and the number of secondary windings.

Should the current transformers be mounted by the customer, the mounting template (see accessory 2) must be requested and the enclosure sealed for current transformer. The current transformers are available in the following versions:

- 1A** Current transformer with 3 active phases and one core per phase;
- 1B** Current transformer with 3 active phases and two cores per phase;
- 1C** Current transformer with 2 active phases and one core per phase;
- 1D** Current transformer with 2 active phases and two cores per phase.

#### Characteristics of the three-phase current transformers

Active phases	3 max
Cores per phase	2 max
First core performance (measurement)	15VA/1
Second core performance (protection)	10VA/5P10
Rated primary current (I <sub>pn</sub> )	30 - 300 A
Rated current	1A for CT with 1 core
Rated secondary current (I <sub>sn</sub> )	5A for CT with 2 cores
Rated normal short-circuit current (I <sub>ter</sub> )	80 x I <sub>pn</sub>
Rated dynamic short-circuit current (I <sub>din</sub> )	350 x I <sub>pn</sub>
Maximum permanent heating current	= I <sub>pn</sub>
Insulation voltage	12 kV
Rated frequency	50/60 Hz
Ambient temperature	55 °C

Free of partial discharges according to ABB T09260 specif.

**N.B.** The table shows the most commonly used transformers. However, on request, transformers with different characteristics are available (please consult us).

<b>F</b>	Rated frequency of the CT.
<b>I<sub>pn</sub></b>	Rated primary current of the CT.
<b>I<sub>sn</sub></b>	Rated secondary current of the CT.

## UniMotor

Kit	Active phases [No]	Cores per phase [No]	F [Hz]	I <sub>pn</sub> [A]	I <sub>sn</sub> [A]	UXAB
1A	3	1	50	30	1	309312101
1A	3	1	50	50	1	309312102
1A	3	1	50	75	1	309312103
1A	3	1	50	100	1	309312104
1A	3	1	50	150	1	309312105
1A	3	1	50	200	1	309312106
1A	3	1	50	300	1	309312107
1A	3	1	60	30	1	309312301
1A	3	1	60	50	1	309312302
1A	3	1	60	75	1	309312303
1A	3	1	60	100	1	309312304
1A	3	1	60	150	1	309312305
1A	3	1	60	200	1	309312306
1A	3	1	60	300	1	309312307
1B	3	2	50	30	5	309312201
1B	3	2	50	50	5	309312202
1B	3	2	50	75	5	309312203
1B	3	2	50	100	5	309312204
1B	3	2	50	150	5	309312205
1B	3	2	50	200	5	309312206
1B	3	2	50	300	5	309312207
1B	3	2	60	30	5	309312401
1B	3	2	60	50	5	309312402
1B	3	2	60	75	5	309312403
1B	3	2	60	100	5	309312404
1B	3	2	60	150	5	309312405
1B	3	2	60	200	5	309312406
1B	3	2	60	300	5	309312407
1C	2	1	50	30	1	309311101
1C	2	1	50	50	1	309311102
1C	2	1	50	75	1	309311103
1C	2	1	50	100	1	309311104
1C	2	1	50	150	1	309311105
1C	2	1	50	200	1	309311106
1C	2	1	50	300	1	309311107
1C	2	1	60	30	1	309311301
1C	2	1	60	50	1	309311302
1C	2	1	60	75	1	309311303
1C	2	1	60	100	1	309311304
1C	2	1	60	150	1	309311305
1C	2	1	60	200	1	309311306
1C	2	1	60	300	1	309311307
1D	2	2	50	30	5	309311201
1D	2	2	50	50	5	309311202
1D	2	2	50	75	5	309311203
1D	2	2	50	100	5	309311204
1D	2	2	50	150	5	309311205
1D	2	2	50	200	5	309311206
1D	2	2	50	300	5	309311207
1D	2	2	60	30	5	309311401
1D	2	2	60	50	5	309311402
1D	2	2	60	75	5	309311403
1D	2	2	60	100	5	309311404
1D	2	2	60	150	5	309311405
1D	2	2	60	200	5	309311406
1D	2	2	60	300	5	309311407

## UNIMOTOR ENCLOSURE SELECTION AND ORDERING

2

### Assembly template for current transformers



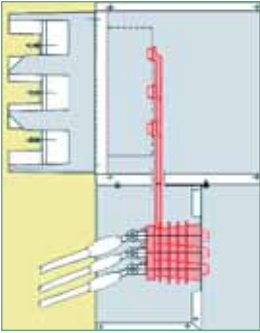
The assembly template allows the monobloc contacts/current transformers to be installed (by the customer) in the UniMotor enclosure. The template is identical for all types of enclosure and/or monobloc.

#### UniMotor

Kit	UXAB
2	309300161

3

### Cable connections



The kit consists of three insulators and three suitably shaped lengths of copper busbar. Application of this accessory allows the connection terminals to be taken to the side of the enclosure to facilitate connection of the medium voltage cables.

#### UniMotor

Kit	UXAB
3	309300321

4

### Earthing switch without key lock



This is a mechanical device which allows the MV line connected to the output terminals of the enclosure to be earthed. Earthing switch operation takes place automatically:

- earthing switch closure takes place on door opening;
- opening earthing switch takes place during racking-in of the contactor truck.

#### UniMotor

Kit	UXAB
4	309300141

5

### Key lock for earthing switch



This is a mechanical device which allows the earthing switch operation to be locked. The lock is available in the following versions.

- 5A** Key free with earthing switch closed.
- 5B** Key free with earthing switch open.

#### UniMotor

Kit	UXAB
5A	309300502
5B	309300501

### Key lock on isolation operation

This is a mechanical device which allows the withdrawable truck racking-in and racking-out operation to be locked.

The lock is available in the following versions.

- 6A** Key lock on racking-out operation; key free with the truck racked out.
- 6B** Key lock on the racking-out operation; key free with the truck racked in.

#### UniMotor

Kit	UXAB
<b>6A</b>	<b>309300121</b>
<b>6B</b>	<b>309300122</b>



6

### Microswitches for fuse intervention

The microswitches are activated following intervention of one of the fuses in the contactor truck. Inserted in a suitable electric circuit, they allow the following:

- contactor with electrical latching: contactor opening. If provided, the second microswitch allows electrical signalling or a remote lock;
- contactor with mechanical latching: contactor opening. If provided, the second microswitch does not allow reclosing.

- 7A** Nr. 1 microswitch for fuse intervention.
  - 7B** Nr. 2 microswitches for fuse intervention.
- At least one microswitch is always supplied.

#### UniMotor

Kit	UXAB
<b>7A</b>	<b>309300171</b>
<b>7B</b>	<b>309300172</b>

#### Electrical characteristics of the contact

Un	Icu	cosφ	T
220 V~	10 A	0.4	–
220 V~	5 A	0.4	–
220 V–	1 A	–	10 ms



7

### Position contacts of the withdrawable truck

Inserted in a suitable electric circuit these allow the position of the withdrawable truck in the enclosure to be signalled.

- 8A** Nr. 5 auxiliary contacts for contactor racked in.
- 8B** Nr. 10 aux. contacts for contactor racked in.
- 8C** Nr. 5 auxiliary contacts for contactor isolated.
- 8D** Nr. 10 auxiliary contacts for contactor isolated.

#### UniMotor

Kit	UXAB
<b>8A</b>	<b>309300301</b>
<b>8B</b>	<b>309300302</b>
<b>8C</b>	<b>309300311</b>
<b>8D</b>	<b>309300312</b>

#### Electrical characteristics of the contact

Un	Icu	cosφ	T
220 V~	10 A	0.4	–
220 V~	5 A	0.4	–
220 V–	1 A	–	10 ms



8

## UNIMOTOR ENCLOSURE SELECTION AND ORDERING

9

**Lifting truck**

This is a truck which facilitates the contactor lifting operations for racking it into the enclosure.

**UniMotor**

Kit	UXAB
9	309300331


## POWERCUBE UNITS

PowerCube PB1/M unit	40
PowerCube PB1/E unit	41
PowerCube PB/F fixed parts	42

## POWERCUBE UNITS

### PowerCube PB1/M unit



Rated voltage	<b>U [kV]</b>	<b>12</b>	
Rated insulation voltage	<b>Ui [kV]</b>	<b>12</b>	
Withstand voltage at 50 Hz	<b>U (1 min) [kV]</b>	<b>28</b>	
Impulse withstand voltage	<b>Uw [kV]</b>	<b>75</b>	
Rated frequency	<b>F [Hz]</b>	<b>50-60</b>	
Rated current (40 °C)	<b>In [A]</b>	<b>400 (*)</b>	
Rated short-time withstand current	<b>Icw [kA]</b>	<b>31.5</b>	
Overall dimensions		<b>H [mm]</b>	<b>1690</b>
		<b>L [mm]</b>	<b>600</b>
		<b>D [mm]</b>	<b>1110</b>
Weight	[kg]	<b>180</b>	
Tropicalisation	<b>IEC 721-2-1</b>	<b>■</b>	
Electromagnetic compatibility	<b>EN 50081.../50082...</b>	<b>■</b>	
Degree of protection with door closed	<b>IP</b>	<b>4X</b>	
Technical catalogue	-	<b>1VCP000091</b>	

(\*) Rated current of the contactor. The minimum rated current of the PowerCube unit is 630 A.

## PowerCube PB1/E unit

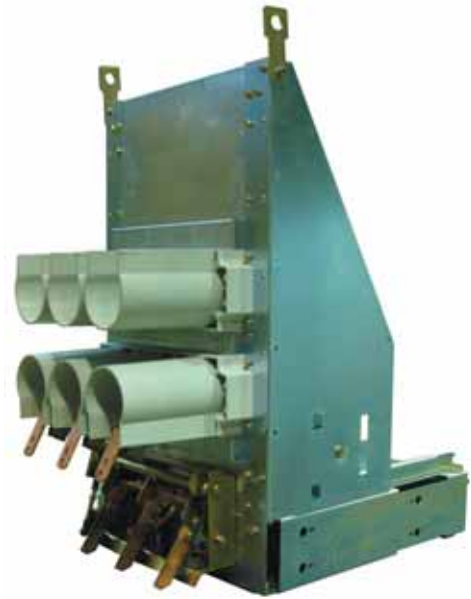



Rated voltage		12
Rated insulation voltage	<b>U</b> [kV]	12
Withstand voltage at 50 Hz	<b>Ui</b> [kV]	28
Impulse withstand voltage	<b>U (1 min)</b> [kV]	75
Rated frequency	<b>Uw</b> [kV]	50-60
Rated current (40 °C)	<b>F</b> [Hz]	400 (*)
Rated short-time withstand current	<b>In</b> [A]	31.5
Overall dimensions		<b>Icw</b> [kA] 1120
		<b>H</b> [mm] 600
		<b>L</b> [mm] 1110
		<b>D</b> [mm] 180
Weight		[kg] ■
Tropicalisation		■
Electromagnetic compatibility	<b>IEC 721-2-1</b>	■
Degree of protection with door closed	<b>EN 50081.../50082...</b>	4X
Technical catalogue	<b>IP</b>	1VCP000091

(\*) Rated current of the contactor. The minimum rated current of the PowerCube unit is 630 A.

## POWERCUBE UNITS

### PowerCube CB/F fixed parts



Rated voltage	<b>U</b> [kV]	<b>12</b>
Rated insulation voltage	<b>Ui</b> [kV]	<b>12</b>
Withstand voltage at 50 Hz	<b>U (1 min)</b> [kV]	<b>28</b>
Impulse withstand voltage	<b>Uw</b> [kV]	<b>75</b>
Rated frequency	<b>F</b> [Hz]	<b>50-60</b>
Rated current (40 °C)	<b>In</b> [A]	<b>400 (*)</b>
Rated short-time withstand current	<b>Icw</b> [kA]	<b>31.5</b>
Overall dimensions	 <b>H</b> [mm]	<b>1098</b>
	<b>L</b> [mm]	<b>600</b>
	<b>D</b> [mm]	<b>1016</b>
Weight	[kg]	<b>180</b>
Tropicalisation	<b>IEC 721-2-1</b>	<b>■</b>
Electromagnetic compatibility	<b>EN 50081.../50082...</b>	<b>■</b>
Degree of protection with door closed	<b>IP</b>	<b>4X</b>
Technical catalogue	-	<b>1VCP000253</b>

(\*) Rated current of the contactor. The minimum rated current of the PowerCube unit is 630 A.

## SPECIFIC PRODUCT CHARACTERISTICS

Electromagnetic compatibility	44
Resistance to vibrations	44
Tropicalisation	44
Installation of fixed contactor and fixed contactor with fuses	44
Altitude	44
Electronic feeder power consumption	46
Environmental protection programme	46
V-Contact - VRC interchangeability	46
Service conditions depending on the load	47
Derating in switchgear according to ambient temperature	57

## SPECIFIC PRODUCT CHARACTERISTICS

### Electromagnetic compatibility

The V-Contact vacuum contactors ensure operation without unwarranted interventions when there are interferences caused by electronic apparatus, by atmospheric disturbances or by discharges of electrical type.

They also do not cause any interference with electronic apparatus in the vicinity of the installation.

The above is in compliance with IEC 60694, 60470, 61000-6-2, 61000-6-4 Standards, as well as with EEC 89/336 European Directive regarding electromagnetic compatibility (EMC), and the feeders are CE marked to indicate their compliance.

### Resistance to vibrations

V-Contact vacuum contactors are unaffected by mechanically or electromagnetically generated vibrations.

### Tropicalisation

V-Contact vacuum contactors are manufactured in compliance with the prescriptions regarding use in hot-humid-saline climates.

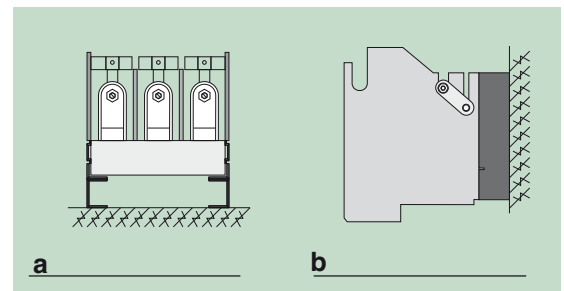
All the most important metal parts are treated against corrosive factors corresponding to ambient conditions C in compliance with the UNI 3564-65 Standards.

Galvanization is carried out in compliance with the UNI ISO 2081 Standard, classification code Fe/Zn 12, with thickness of  $12 \times 10^{-6}$  m, protected by a layer of conversion mainly consisting of chromates in compliance with the UNI ISO 4520 Standard. These characteristics mean that all the V-Contact series apparatus and their accessories comply with climate graph no. 8 of the IEC 721-2-1 and IEC 68-2-2 (Test B: Dry Heat) / IEC 68-2-30 (Test Bd: Damp Heat, cyclic) Standards.

### Installation of fixed contactor and fixed contactor with fuses

The performance of the fixed contactor remains unaltered in the installation positions indicated:

- a) normal position;
- b) vertical with the moving contacts at the top.



**N.B.:** the fixed contactor with fuses or with VT can only be installed in position a).

### Altitude

It is well-known that the insulating properties of air decrease as the altitude increases. This phenomenon must always be taken into account during the design stage of insulating parts of equipment which is to be installed over 1000 m above sea level. In this case a correction coefficient must be applied, which can be taken from the graph drawn up according to IEC and CEI Standard indications. The following example gives a clear interpretation of the indications given above.

#### Example

- Installation altitude 2000 m
- Use at rated voltage of 7 kV
- Power frequency withstand voltage 20 kV rms
- Impulse withstand voltage 50 kVp
- Ka Factor = 1.13 (see graph).

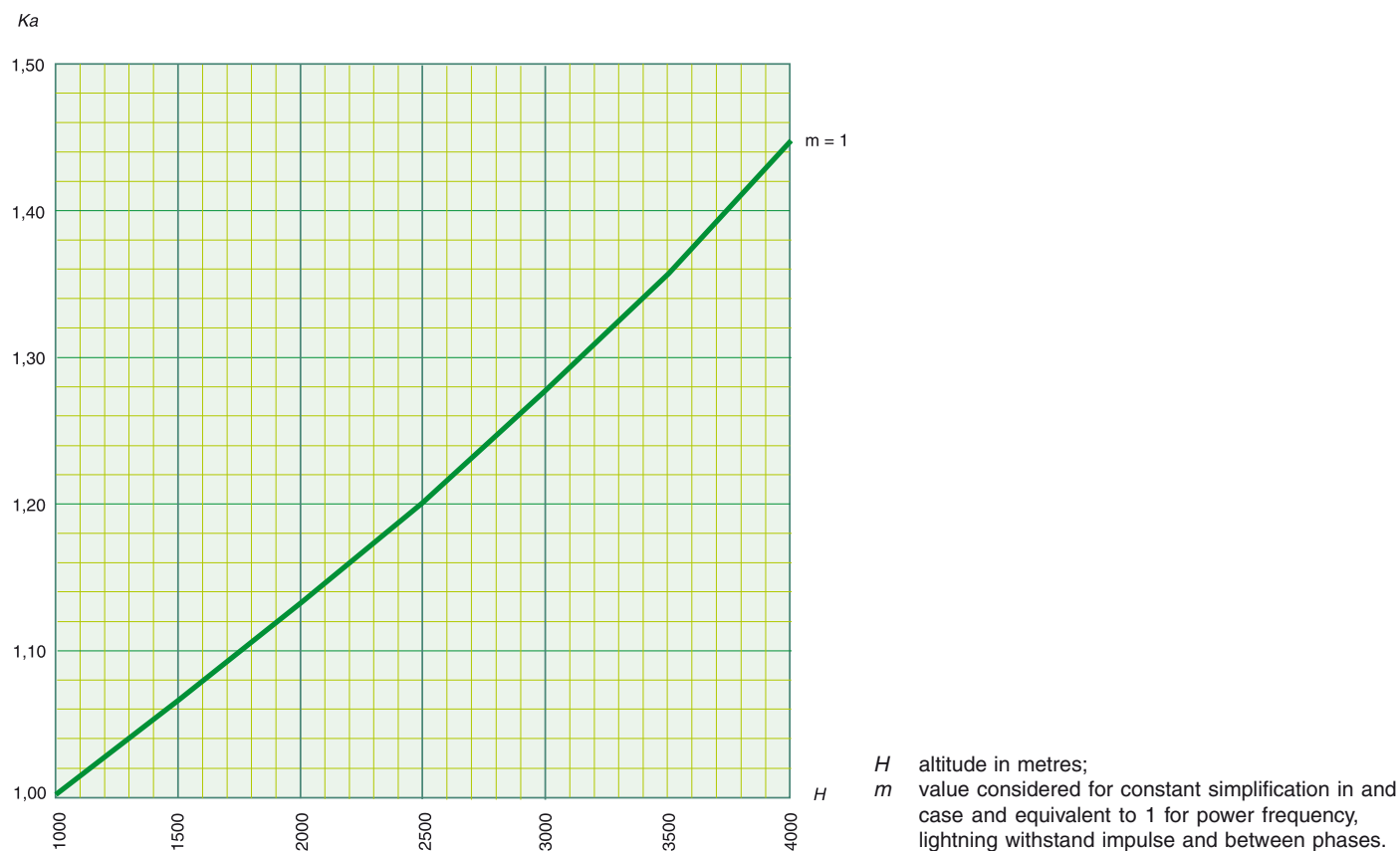
These factors can be calculated from the IEC Standard with the following equation:

$$K_a = e^{m(H-1000)/8150}$$

According to the above parameters, the apparatus will have to withstand the following values (test values at zero altitude i.e. at sea level):

- Power frequency withstand voltage equal to:  
20 x 1.13 = 22,6 kVrms
- Impulse withstand voltage equal to:  
50 x 1.13 = 56,5 kVp.

From the above, it can be deduced that for installations at an altitude of 2000 m above sea level, with an operating voltage of 7 kV, apparatus with a rated voltage of 12 kV characterized by power frequency withstand voltage of 28 kV rms and with 60/75 kVp impulse withstand voltage must be provided.



## SPECIFIC PRODUCT CHARACTERISTICS

### Electronic feeder power consumption

Feeder type	Rated Voltage	Inrush current Peak value (*)		Start-up current r.m.s. Value (*)		Continuous service current (*)
	[V]	[A]	[ms]	[A]	[ms]	
1	24 V d.c.	100	1 ms	13	170	0,5
1	30 V d.c.					
1	48 V d.c.			13		
1	60 V d.c.			190		
2	110 V d.c.	8,5	1 ms	6,5	170	0,4
2	125 V d.c.					
2	220 V d.c.	21	1 ms	3,5	170	0,5
2	250 V d.c.					
2	110 V a.c.	21	1 ms	9,5	170	0,5
2	125 V a.c.					
2	220 V a.c.	37	1 ms	5,5	170	0,5
2	250 V a.c.					

(\*) Maximum Values of time and currents

### Environmental protection programme

The V-Contact contactors are constructed in compliance with the ISO 14000 Standards (Guide lines for environmental management).

The production processes are carried out in compliance with the Standards for environmental protection both in terms of reduction of energy consumption and raw materials and of production of waste. This thanks to the environmental management certified system of the production facility. The minimal environmental impact during the life cycle of the product (LCA - Life Cycle Assessment), is obtained by targeted selection of materials, processes and packing made during the design stage.

Production techniques which prepare the products for easy dismantling and easy separation of the components are put into effect when manufacturing the contactors. This is to allow maximum recycling at the end of the useful life cycle of the apparatus.

### V-Contact - VRC interchangeability

#### Withdrawable V/C contactors (for CBE) and V/Z (for ZS1)

Complete physical interchangeability between VRC/ZC and V-Contact V/C and V/Z is guaranteed. For electrical interchangeability, it is necessary to make some modifications to the electrical diagrams

of the enclosures and ZS1 switchgear as indicated below:

- diagram 1VCD400042R0000 for interchangeability between the electric circuits of the V/C - V/Z contactors and VRC/ZC with electromagnetic latching
- diagram 1VCD400043R0000 for interchangeability between the electric circuits of the V/C - V/Z contactors and VRC/ZC with mechanical latching.

#### Withdrawable V/UN contactors (UniMotor)

To guarantee physical interchangeability between V-Contact V/UN and the corresponding versions of the VRC contactor, adaptation kits are provided for the UniMotor enclosure:

- retrofitting kit for V7/UN contactor:  
**1VCF 309400R0271**
- retrofitting kit for V12/UN contactor:  
**1VCF 309400R0272.**

For electrical interchangeability, it is necessary to make some modifications to the electrical diagrams of the enclosures as indicated below:

- diagram **1VCF400040R0000** for interchangeability between the electric circuits of the V-Contact V/UN contactors and VRC/UniMotor contactors with electromagnetic latching
- diagram **1VCF400041R0000** for interchangeability between the electric circuits of the V-Contact V/UN contactors and VRC/UniMotor contactors with mechanical latching.



The VRC HD contactor (special version for switching capacitor banks) can be replaced with the standard contactors whose service parameters are those indicated in the table on page 10. For different values, please contact us.

## Service depending on the load

### Motor control and protection

The motors are usually supplied with low voltage up to a power of 630 kW. Above this power it is preferable to supply them with medium voltage (from 3 to 12 kV) in order to reduce costs and dimensions of all the equipment comprising the circuit.

V-Contact can be used for voltages from 2.2 kV up to 12 kV and for motors up to a power of 5000 kW, thanks to the simplicity and sturdiness of the operating mechanisms and to the long life of the main contacts.

To ensure protection against short-circuits, it is necessary to combine the contactors with appropriate current-limiting fuses. This solution also means the equipment costs can be reduced even further on the load side (cables, current transformers, busbar and cable fixing devices, etc.), and also means the user is unlikely to have to carry out any subsequent installation extensions with consequent increases in network power.

### Procedure for selecting the fuses for motor protection

The choice of fuses suitable for motor protection must be carried out by checking the service conditions.

The following data should be taken into consideration:

- supply voltage
- starting current
- starting duration
- number of start-ups/hour
- full motor load current
- short-circuit current of the installation.

Achievement of trip co-ordination with the other protection relays is also one of the selection criteria in order to ensure adequate protection of the contactor, the current transformers, the cables, the motor itself and any other equipment present in the circuit which might be damaged because of prolonged overloads or specific let-through energy ( $I^2t$ ) above the withstand energy.

Protection against short-circuit is carried out by the fuses, always selected with a higher rated current than the motor to prevent their intervention on start up. This does not allow their use as protection against repeated overloads - a function not guaranteed by them anyway - especially with current values included up to the end of the initial asymptotic stretch of the characteristic curve.

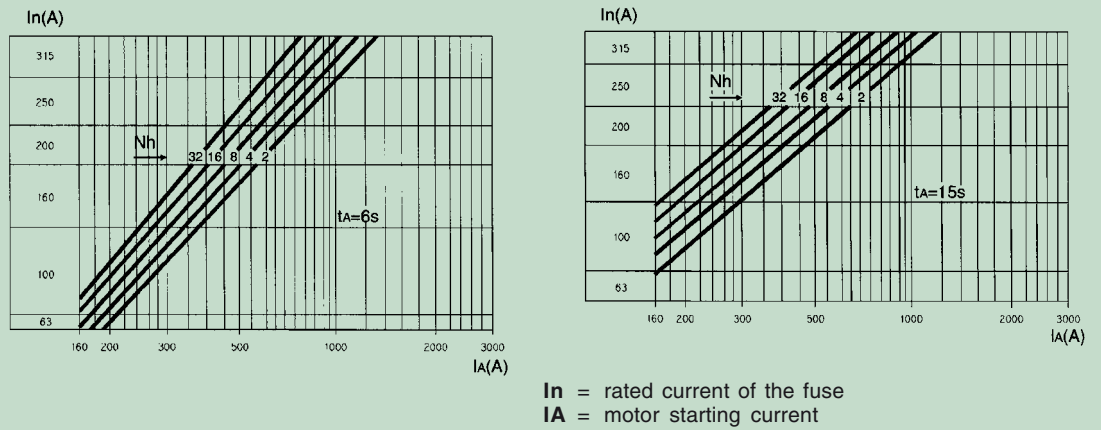
An inverse or definite time delay relay is therefore always required for protection against overloads.

This protection must be coordinated with the protection carried out by the fuse so that the relay and fuse curves intersect at a point which allows:

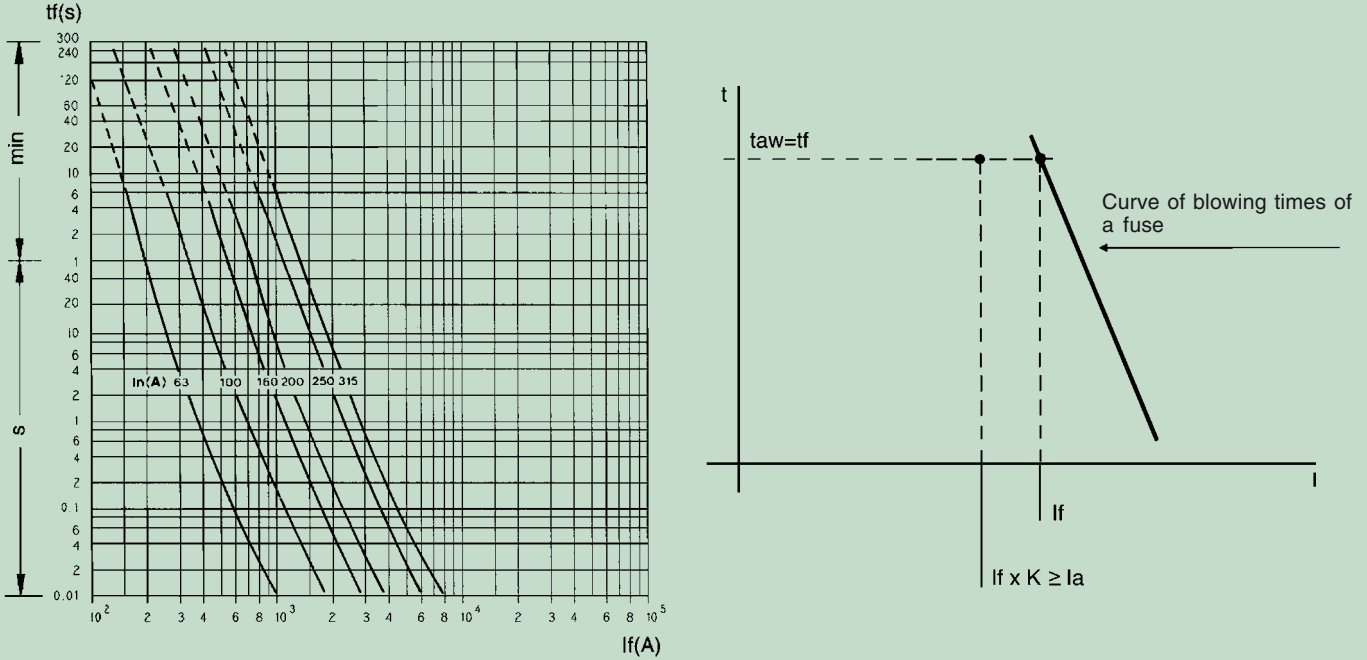
- 1) Motor protection against overcurrents due to overloads, single-phase running, blocked rotor and repeated start-ups. Protection given by inverse and definite time indirect relays, which act on the contactor.
- 2) Protection of the circuit against fault currents between phases and to earth, of low value, given by inverse or definite time relays, which must only trip for short-circuit values which can be interrupted by the contactor.
- 3) Circuit protection for fault currents above the contactor breaking capacity up to the maximum withstand fault current. Protection entrusted to the fuse.

## SPECIFIC PRODUCT CHARACTERISTICS

**Fig. A - Fuse selection curves for motor starting. ABB CMF type fuses.**

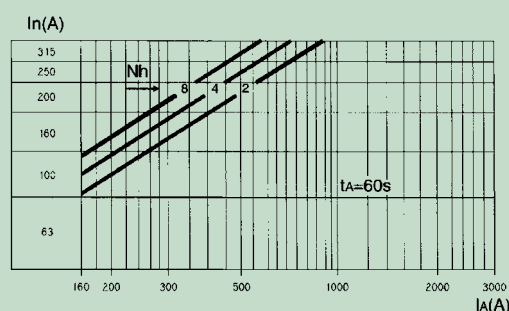


**Fig. B - Blowing time curve and table for selection of the K factor. ABB CMF type fuses.**



**Table for selection of the K factor**

$U_n$ [kV]	$I_n$ [A]					
3.6	63	100	160	200	250	315
7.2	63	100	160	200	250	315
12	63	100	160	200	—	—
<b>K</b>	0.75	0.75	0.7	0.7	0.6	0.6



$N_h$  = number of motor start-ups per hour  
 $t_A$  = maximum motor starting time

To check the service conditions, proceed as follows:

- **Rated voltage  $U_n$ .** This must be equal to or higher than the service voltage of the installation. The network level of insulation must be checked to ensure it is higher than the value of the operating overvoltage generated by the fuses, which, for the fuses used by ABB, is well below the limit fixed by the IEC 282-1 Standards.
- **Rated current  $I_n$ .** This must be selected by consulting the diagrams in fig. A which refer to starting with fairly even time intervals, except for the first two start-ups of each hourly cycle which can take place in immediate succession. Each diagram refers to a different starting time: 6 s - 15 s - 60 s respectively. In case of start-ups occurring close together, the starting current must also be checked to ensure it does not exceed the value of  $I_f \times K$ , where  $I_f$  is the fuse blow out current in correspondence with the motor starting time and  $K$  is a minor factor of the unit, a function of the  $I_n$  of the fuse taken from the table in fig. B.
- **Full load current of the motor.** The rated current of the fuse must have a value equal to or greater than 1.33 times the value of the rated full load current of the motor. This condition is, moreover, always obtained for the motors started under full voltage for which the procedure described for selection of the rated current of the fuse necessarily imposes values which are always greater than 1.33  $I_n$ .

- **Short-circuit current.** The short-circuit current-limiting curves shown in fig. C make it possible to appreciate the short-circuit current limiting features on the load side of the fuses involved in the fault, which implies the possibility of smaller sizing of the equipment on the load side.

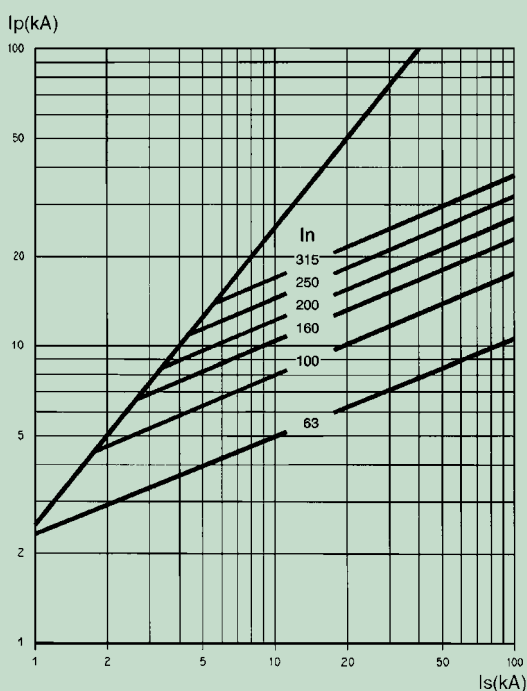
#### Example of inverse time fuse-relay coordination for overload

Motor characteristics:

$P_n$	=	1000 kW
$U_n$	=	6 kV
$I_{avv}$	≈	5 $I_n$ = 650 A
$T_{avv}$	=	6 s
No. operations/hour	=	16.

From the curve with starting time 6 s in fig. A, in correspondence with the starting current value 650 A, the straight line traced for 16 start-ups per hour intersects with the field of the 250 A fuse.

**Fig. C** - Short-circuit current-limiting curves. ABB CMF type fuses.



$I_s$  = symmetrical prospective short-circuit current  
 $I_p$  = current limited by the fuse (peak value)

## SPECIFIC PRODUCT CHARACTERISTICS

From the blow-out time curve it can be seen that the 250 A fuse blows in 6 s (starting time) when it is crossed by a current of 1800 A.

From the table in fig. B, the K coefficient for the 250 A size is 0.6, from which the value  $I_f \times K = 1080$  A is taken, which is greater than the starting current (650 A). Use of the 250 A fuse is therefore also confirmed by observing this condition, which regards the possibility of start-ups occurring close together.

By observing the blow-out curve of the 250 A fuse, the necessity of using an inverse time or a definite time relay against overloads can be seen. It should be remembered that prolonged overheating, above the temperature foreseen by the insulating class, is dangerous and can seriously jeopardise the life of electrical machines.

Fig. D shows the graph for the motor dealt with in the example.

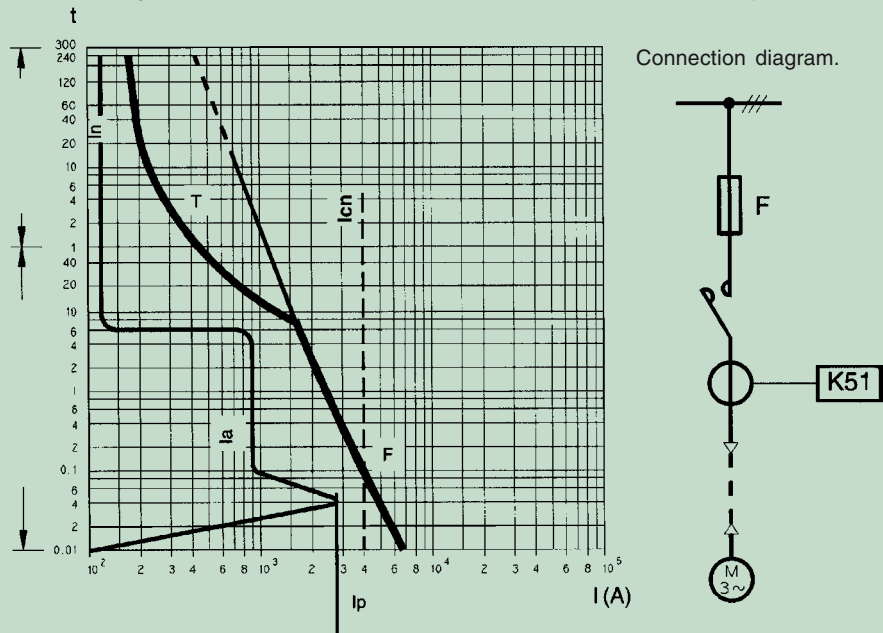
### Motor starting

Motor starting raises the problem of the high inrush power consumption. In most cases, since the motors are asynchronous, the starting current can have the following values:

- asynchronous with simple squirrel cage 4.5 ... 5.5  $I_n$
- asynchronous with double squirrel cage 5 ... 7  $I_n$
- asynchronous with wound motor: low values, depending on the choice of starting resistances.

This current may not be available if the short-circuit power of the network is not sufficiently high and, in any case, may give rise to an intolerable drop in voltage for the whole duration of starting, from the loads deriving from the network itself. A voltage drop between 15 and 20% is usually considered acceptable, though this should be checked in the case of special users.

Fig. D - Graph showing co-ordination between 250 A fuse and inverse time relay.



- I<sub>cn</sub>** = maximum short-circuit current which can interrupt the contactor in amperes
- I<sub>a</sub>** = motor starting current in amperes
- I<sub>n</sub>** = rated motor current in amperes
- t** = time in seconds
- I** = current in amperes
- F** = time-current characteristic of the 250 A fuse
- T** = inverse time characteristic of the indirect relay for protection against overload (K51)
- I<sub>p</sub>** = peak value of the motor connection current

Full voltage starting can take place in an analytical way and is possible in the majority of cases. If, from the calculation, it appears that the starting power causes a greater drop in voltage than is permitted, reduced voltage starting must be carried out with a consequent reduction in the starting current.

For this, starting with a step-down autotransformer is generally used.

For large motors, it may prove advisable to use a transformer dedicated exclusively to the machine; this will be slightly more powerful than is required for the motor. Starting therefore takes place with reduced voltage (considerable drop in voltage on the secondary winding of the transformer) without the rest of the installation being affected.

With the appropriate combination of the UniMotor type switchgear and different enclosures, with withdrawable contactors and suitable accessories, any layout can be achieved for motor start-up, control, protection and measurement.

Fig. E (following page) shows some typical electrical diagrams which can be achieved with withdrawable contactors in enclosures.

#### **Transformer protection and fuse selection**

When contactors are used to control and protect transformers, they are fitted with a special type of current-limiting fuses which guarantee selectivity with other protection devices and can withstand the high switching-in currents of the transformers without being damaged.

Contrary to what is required for motors, protection against overcurrents on the medium voltage side

of the transformer is not indispensable in this case, since this task is carried out by the protection on the low voltage side. Protection on the medium voltage side can be entrusted to the fuse alone, which must be selected taking into account the no-load switching-in current, which can take on values up to 10 times the rated current for smaller transformers and those built with punched sheets with directed crystals.

The maximum switching-in current is therefore obtained when the circuit-breaker closes in correspondence with the voltage passing through zero.

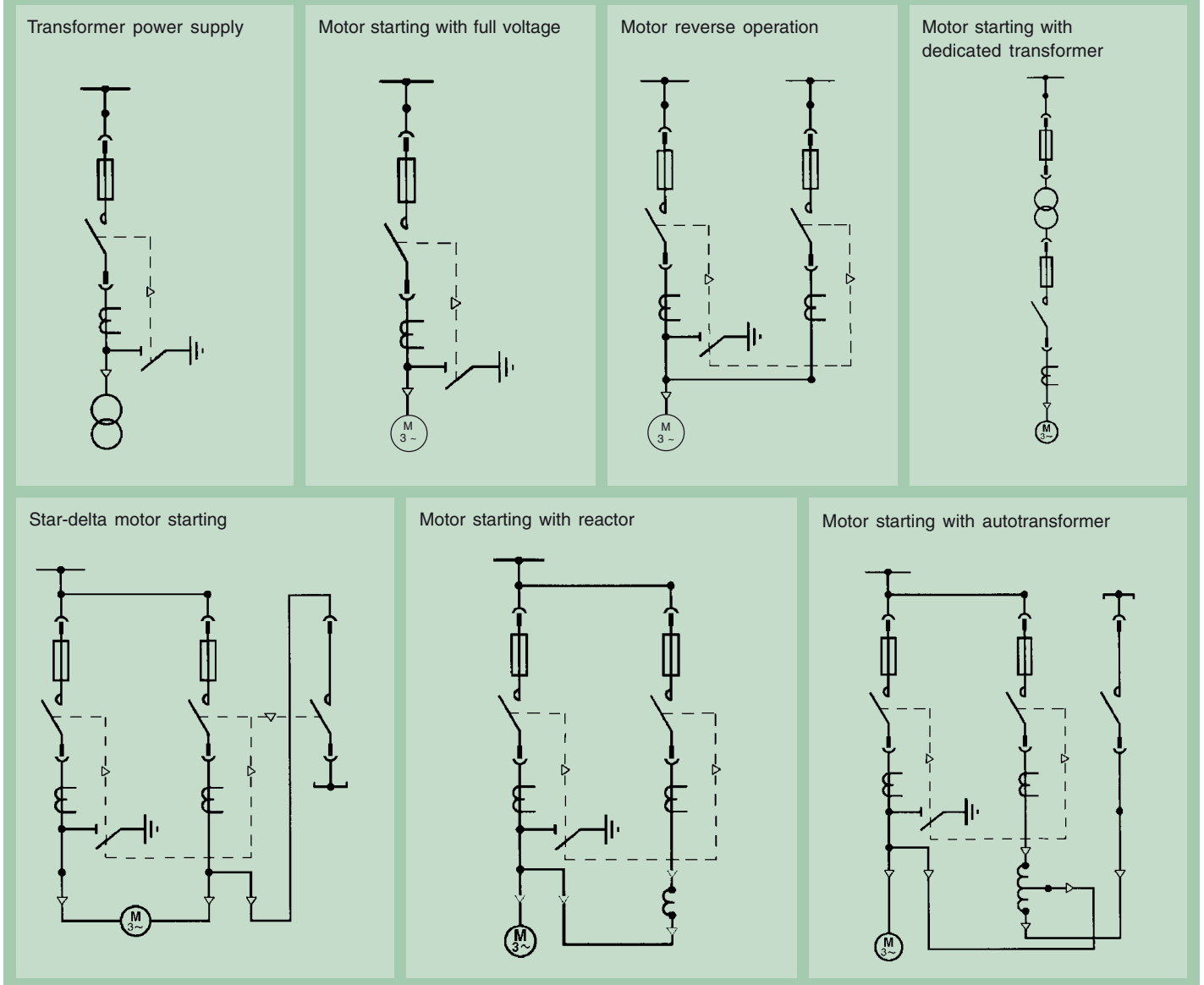
Another result which must be ensured is protection against faults in the low voltage winding and in the piece connecting this to the circuit-breaker on the secondary, avoiding the use of fuses with excessively high rated current, to guarantee short-time tripping even under these fault conditions.

A rapid check of the short-circuit current at the secondary terminals of the transformer and on the supply side of the circuit-breaker on the secondary, if placed at a notable distance, makes it possible to check the trip time on the fuse blow-out curve.

The table to be used given on the following page takes both the conditions required into consideration, i.e. a sufficiently high rated current to avoid unwarranted blow-outs in the no-load switching-in phase and, in any case, of a value which will ensure machine protection against faults on the low voltage side.

## SPECIFIC PRODUCT CHARACTERISTICS

**Fig. E - Typical diagrams of transformer power supply and motor starting**



### Selection table for transformer fuses

Rated voltage [kV]	Rated power of transformer [kVA]														
	100	125	160	200	250	315	400	500	630	800	1000	1250	1600	2000	2500
	Rated current of fuse [A]														
3.6	40	40	63	63	63	63	100	100	160	160	200	250	315	--	--
5	25	25	40	40	63	63	63	80	100	100	160	200	200	250	315
6.6	25	25	25	40	40	63	63	63	80	100	100	160	200	200	250
7.2	25	25	25	40	40	63	63	63	63	100	100	160	160	160	200
10	16	16	25	25	25	40	40	63	63	63	80	100	100	160	160
12	16	16	16	25	25	25	40	40	63	63	63	80	100	160	160

### Connection of capacitor banks

The presence of current transients, which occur during switching-in of a capacitor bank, requires attention during the calculation procedures to define the amount to select the switching equipment which is suitable for connecting/disconnecting the bank and for its protection in the case of overload.

To make this calculation, the power factor correction installations must be divided into two types:

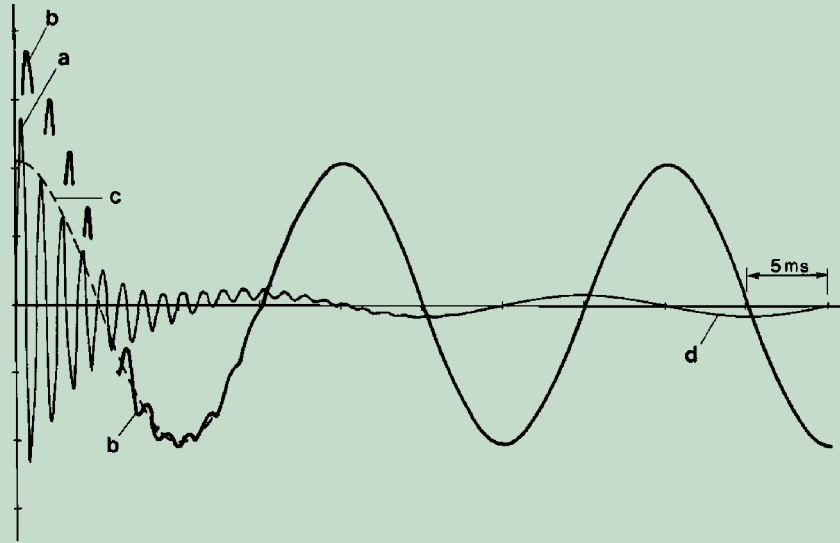
- installations with a single three-phase capacitor bank (single bank installations)
- installations with more than one three-phase capacitor bank, which can be connected separately (multiple bank installations).

In the first type of installation there is only one type of switching-in transient, called switching-in transient of a single capacitor bank to the network: an example of typical current transient is shown in fig. F.

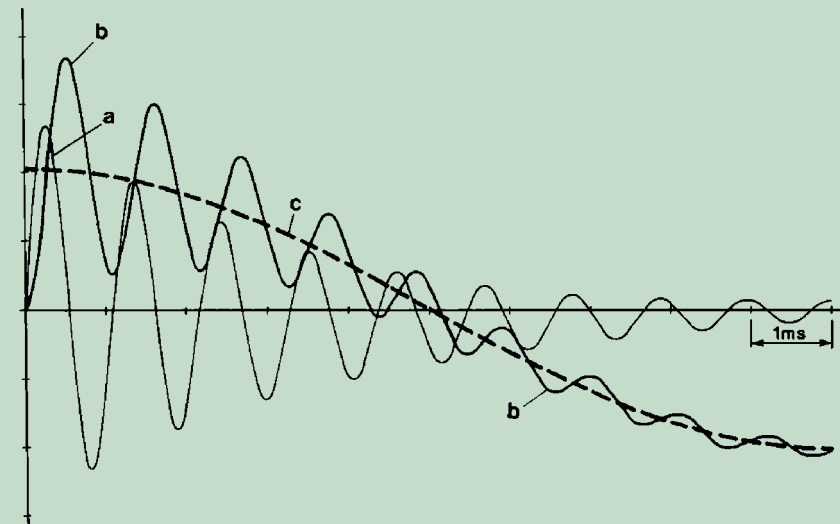
In the second type of installation there are two types of switching-in transients: on connection of the first capacitor bank there is the switching-in transient of a capacitor bank to the network; on connection of the other banks there is a different transient called the switching-in transient of a capacitor bank to the network with other banks already supplied in parallel. In this case, the current transient is the type shown in fig. G.

## SPECIFIC PRODUCT CHARACTERISTICS

Fig. F - Example of a current transient during connection of a single capacitor bank.



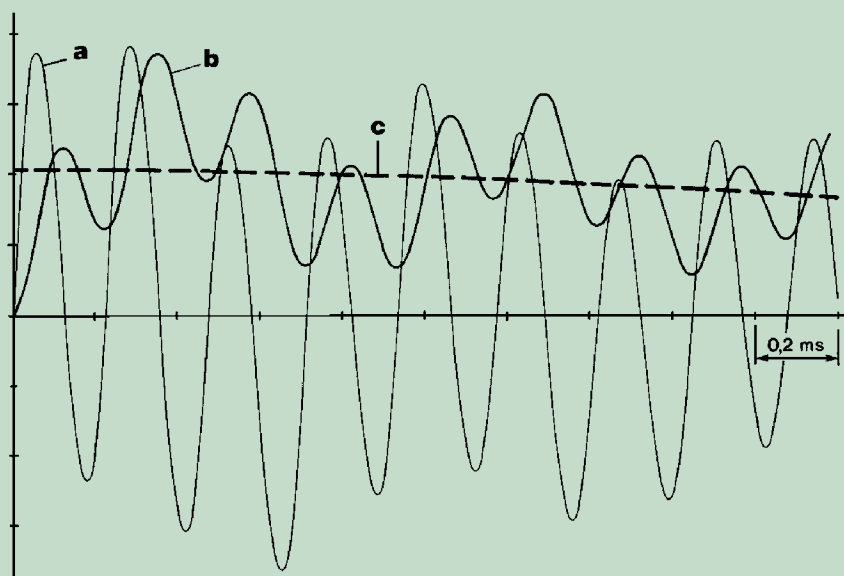
Path of the current and voltage during and after the switching-in transient.



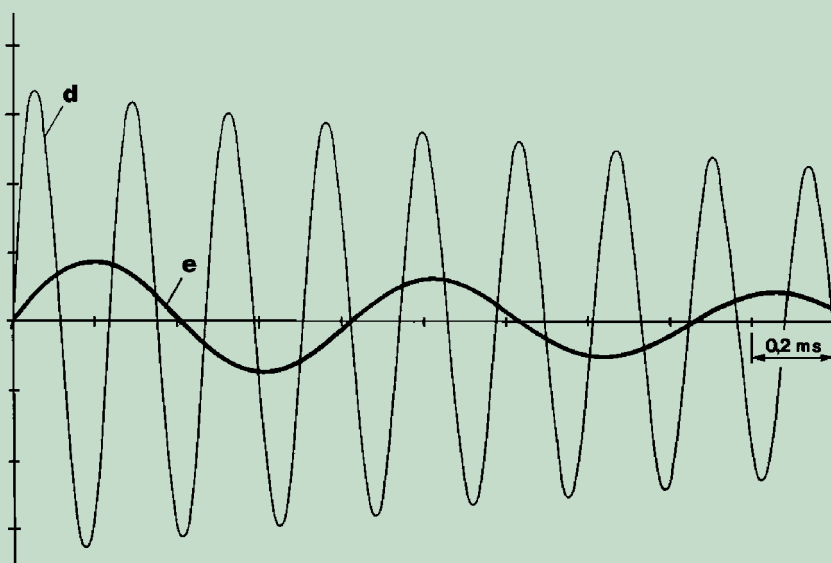
- a = Transient switching-in current: first peak at 600 A and 920 Hz frequency.
- b = Transient voltage at the 400 kVAR bank terminals.
- c = Power supply phase voltage  $10/\sqrt{3} = 5.8$  kV.
- d = Rated bank current at 50 Hz: 23.1 A.

Path of the current and voltage during the first 10 ms of the switching-in transient.

**Fig. G** - Example of a transient current during connection of a capacitor bank with another one already supplied with voltage.



Path of the current and voltage during the first 2 ms of the switching-in transient.



Path of the two components of the total current (see graph above).

- a** = Transient switching-in current: 1800 A peak and 4280 Hz frequency.
- b** = Transient voltage at the 400 kVAR bank terminals
- c** = Power supply phase voltage:  $10\sqrt{3} = 5.8$  kV.
- d** = Component at 4280 Hz frequency of the transient switching-in current.
- e** = Component at 1260 Hz frequency of the transient switching-in current.

## SPECIFIC PRODUCT CHARACTERISTICS

### Selection of contactors suitable for connection of banks

The CEI 33-7 and IEC 871-1/2 Standards specify that the capacitor banks "... must be able to operate correctly under overload with an effective line current value up to 1.3  $I_n$ , not taking into account the transients".

The switching, protection and connection devices must therefore be designed to withstand continuously a current 1.3 times the current there would be at the rated sinusoidal voltage and at the rated frequency.

According to the effective value of the capacity, which may also be 1.10 times the rated value, this current can have a maximum value of  $1.3 \times 1.10 = 1.43$  times the rated current.

It is therefore advisable to select the rated normal current of the contactor for operating the capacitor bank at least equal to 1.43 times the rated current of the bank.

The V-Contact contactors completely fulfil the requirements of the Standards and in particular those regarding connection and disconnection operations of banks and overvoltages which, in any case, do not exceed three times the peak value of the rated phase voltage of the installation. It is necessary to apply voltage surge arresters for the V12 contactors.

### Single bank

The parameters (peak value and frequency) of the current transient present in the case of connection of the bank to the network, are usually of notably smaller size than those in the case of multiple banks. It is, however, necessary to check the values with the calculation and make sure that the peak current is equal to or less than 8 kA peak.

### Two or more banks (back-to-back)

In the case of several banks, it is necessary to make the calculations regarding the installation, considering operation of a single bank with the other capacitor banks already connected.

Under these conditions, it is necessary to check that:

- the maximum switching-in current does not exceed 8 kAp;
- the switching-in current frequency does not exceed 2500 Hz.

For switching-in current values under 8 kAp, the switching-in frequency can be increased so that the product

$$I_p \text{ (kA)} \times f \text{ (Hz)}$$

is less than 20,000.

To calculate the switching-in current and frequency, refer to the ANSI C37.012 Standards or the IEC 62271-100 Appendix H Standards. Should higher values than those indicated be obtained in the calculations, it is necessary to connect air reactors of suitable value in the circuit. The use of a reactor is also recommended in the case of frequent contactor operations with high switching-in frequencies.

### Selection of fuses for capacitor bank protection

The fuse placed in series with the contactor, which guarantees protection in case of short-circuit, must withstand the switching-in current transients mentioned above, and therefore the value of the specific let-through energy ( $I^2t$ ) of the transient must be less than 0.7 times the minimum rated value of the pre-arc  $I^2t$  of the fuse.

Should this check be negative, and where it is not possible to select larger fuses, the specific let-through energy of the transient must be reduced by placing special resistors in series with the bank. In any case, the rated current of the selected fuse must be at least 2-3 times higher than the rated current of the bank.

The pre-arc  $I^2t$  values of CEF series fuses are shown in the table.

### Minimum value of the pre-arc specific let-through energy ( $I^2t$ ) of the CEF series fuses (for all rated voltages).

$I_n$ [A]	6	10	16	25	40	63	100	160
$I^2t$ [A <sup>2</sup> s]	24	30	120	500	1200	4500	15000	35000

## Declassing in switchgear according to the ambient temperature

### Value of the rated currents for contactor without fuses

Value of the rated currents according to the degree of protection of the external housing of the switchgear and to the ambient temperature (without fuses).

Ambient temperature °C	IP4X [A]	IP5X [A]
40	400	280
45	380	270
50	360	260
55	350	240

### Value of the rated currents in UniMotor switchgear with fuses

Value of the rated currents according to the ambient temperature.

The rated current is a function of the current of the fuses used and of the position of the unit compartments.

As an example, three typical solutions are proposed.

Typical unit		A	B	C
Compartment		3	3	3
Rated current of the fuses	[A]	200	315	–
Rated current	[A]	160	250	–
Compartment		2	2	2
Rated current of the fuses	[A]	315	315	315
Rated current	[A]	200	200	250
Compartment		1	1	1
Rated current of the fuses	[A]	315	315	315
Rated current	[A]	250	200	250



Typical unit		A			B			C		
Compartment		1	2	3	1	2	3	1	2	3
Rated current of the fuse		315	315	200	315	315	315	315	315	–
Rated current of contactor plus fuse		250	200	160	200	200	250	250	250	–
Ambient temperature °C	40	250	200	160	200	200	250	250	250	–
	45	240	190	150	190	190	240	240	240	–
	50	230	180	150	180	180	230	230	230	–
	55	220	170	140	170	170	220	220	220	–

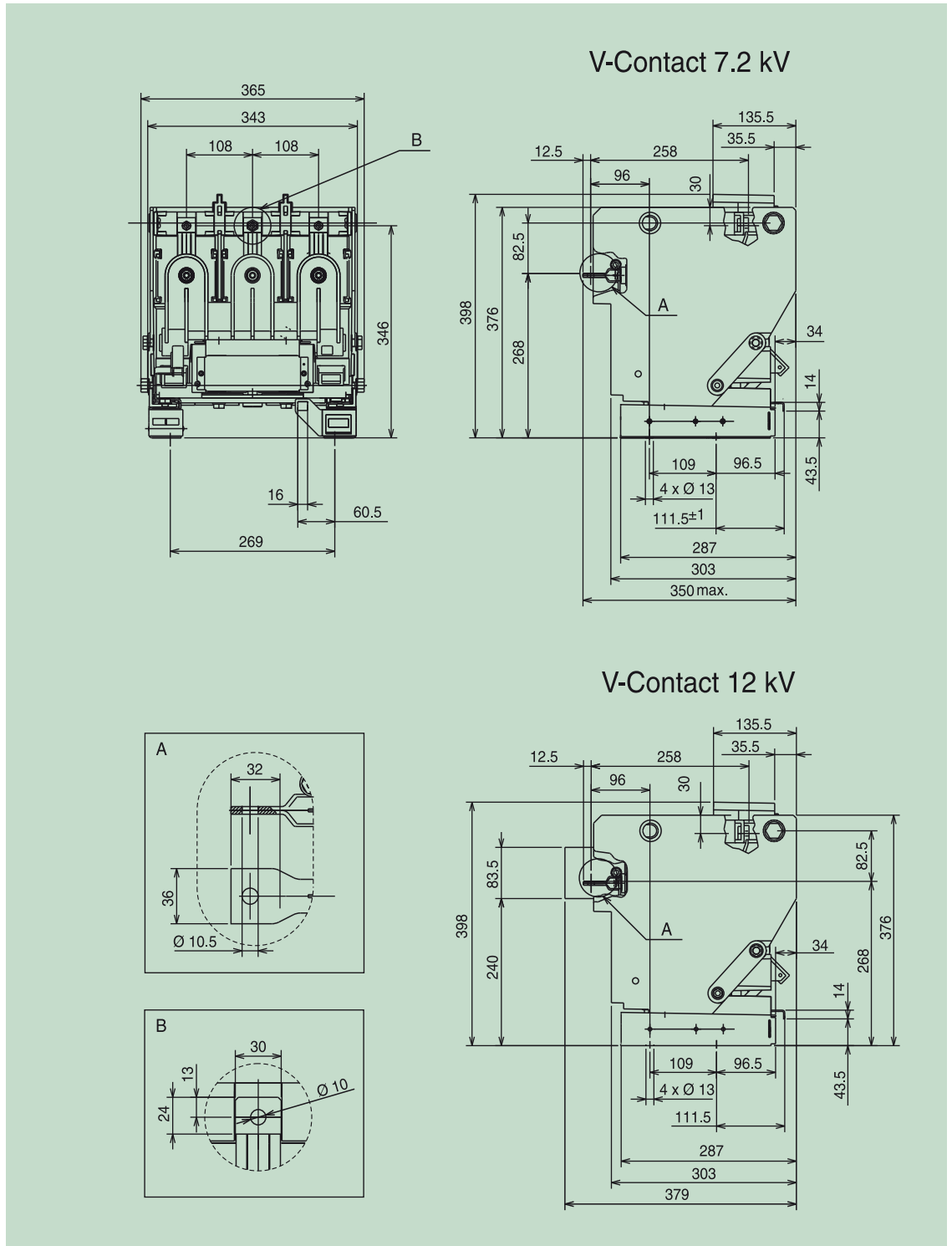


## OVERALL DIMENSIONS

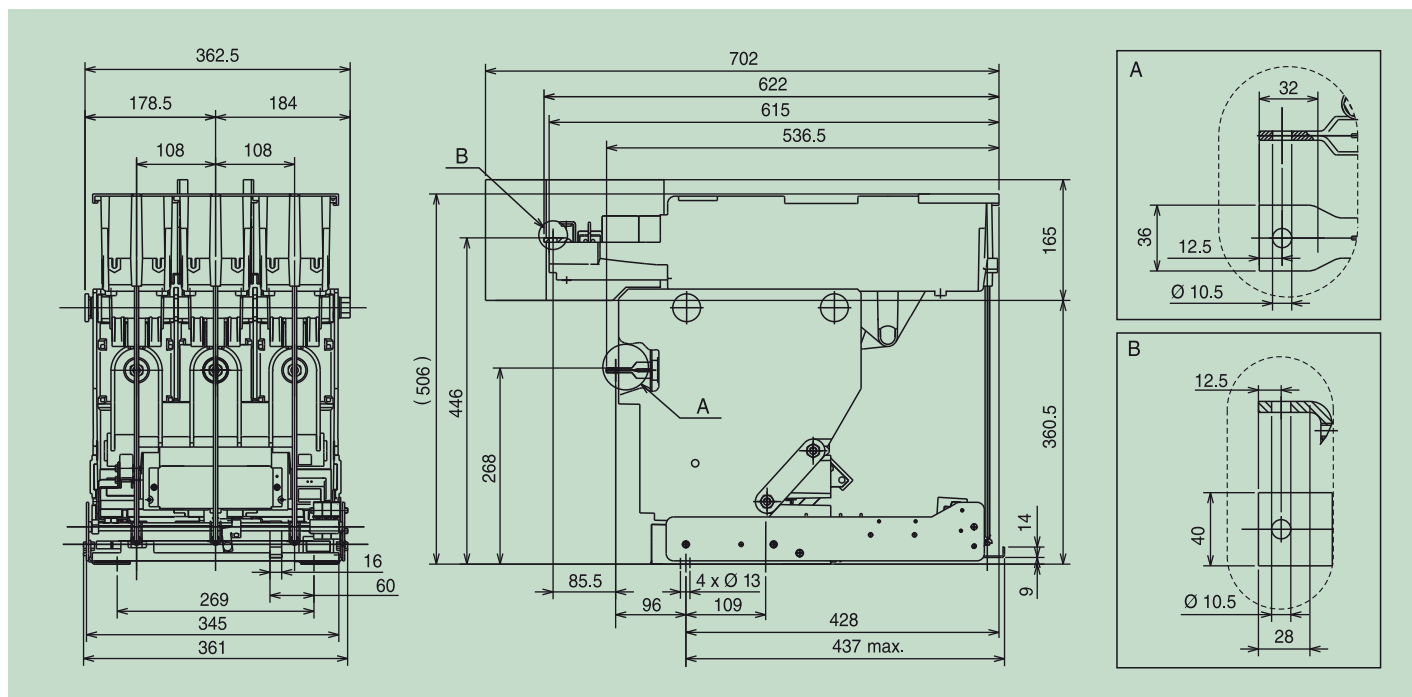
Fixed contactor	60
Fixed contactor with fuses (pole centre distance 108 mm)	61
Fixed contactor with fuses (pole centre distance 150 mm)	61
Fixed contactor with fuses and with voltage transformer for self-supply	62
Withdrawable contactor for CBE enclosure, UniGear switchgear	63
Withdrawable contactor for UniMotor enclosure	64
UniMotor enclosure for V7/UN and V12/UN contactors	65

# OVERALL DIMENSIONS

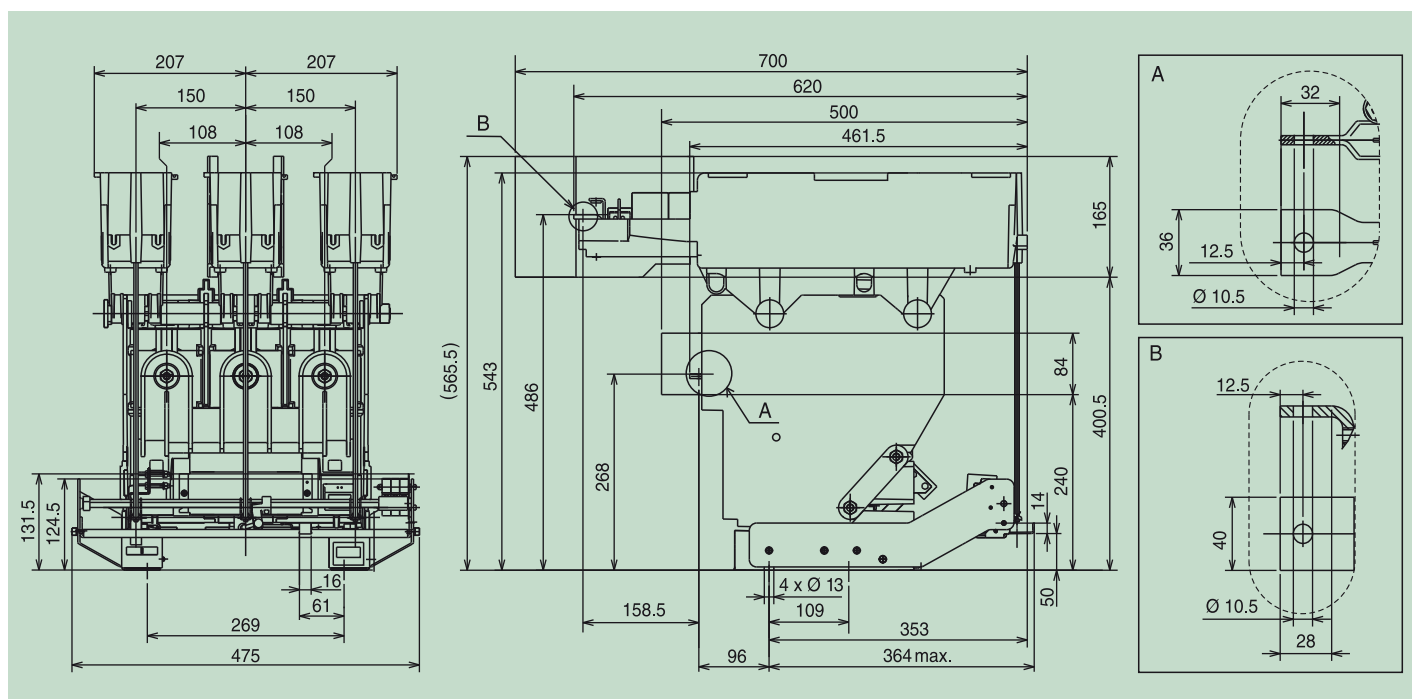
## Fixed contactor



### Fixed contactor with fuses (pole centre distance 108 mm - only 7.2 kV)

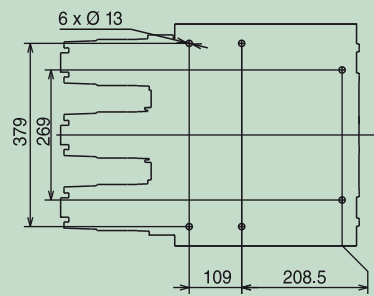
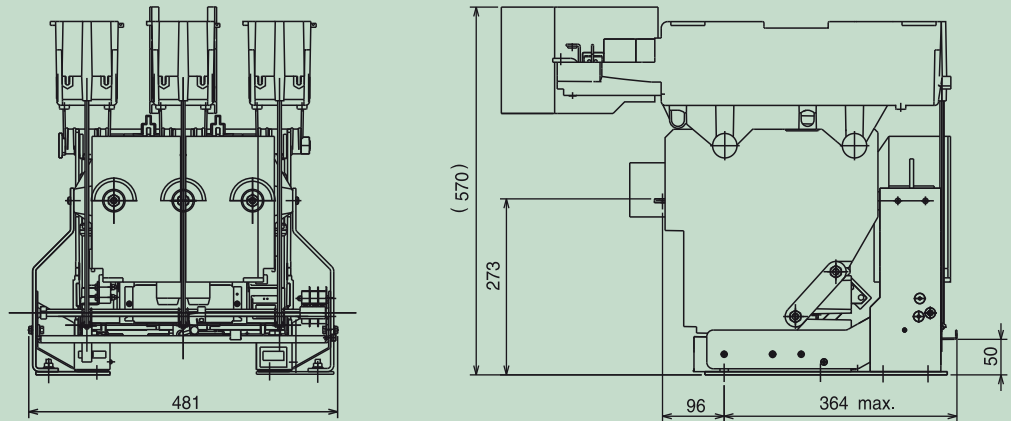


### Fixed contactor with fuses (pole centre distance 150 mm)

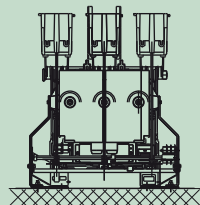


## OVERALL DIMENSIONS

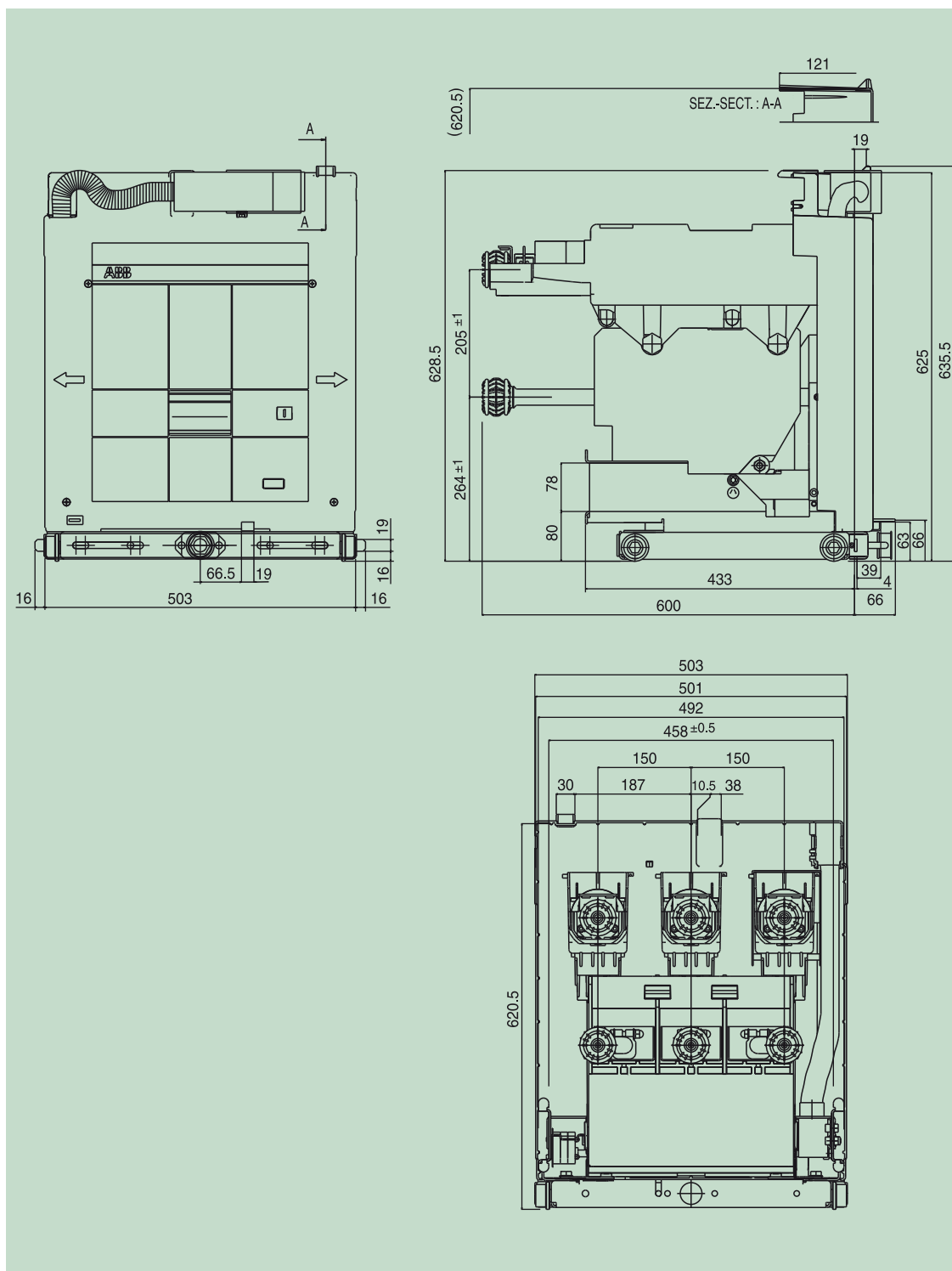
### Fixed contactor with fuses and with voltage transformer for self-supply



### Installation position

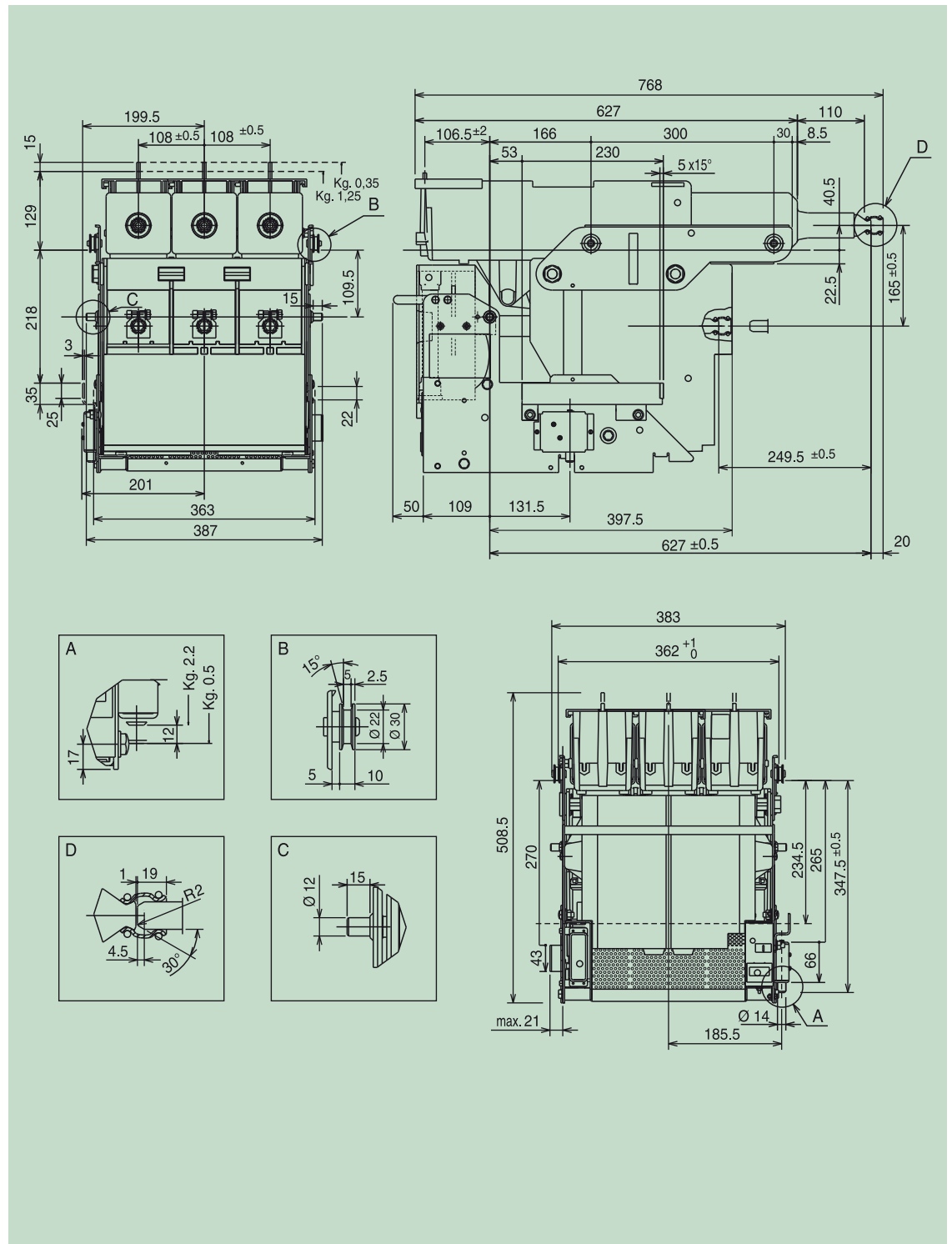


## Withdrawable contactor for CBE enclosure, PowerCube module, UniGear switchgear

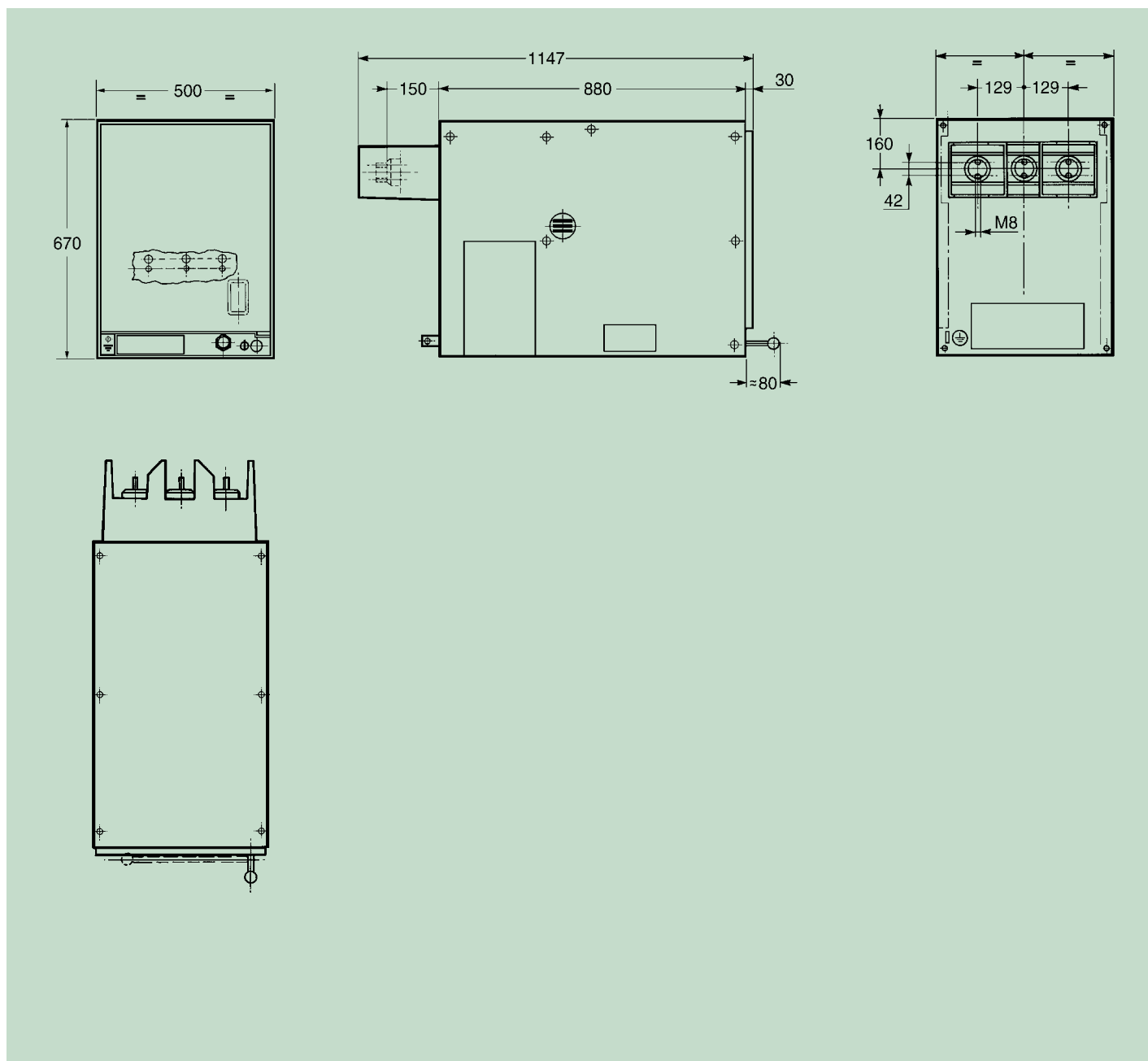


# OVERALL DIMENSIONS

## Withdrawable contactor for UniMotor enclosure



### UniMotor enclosure for V7/UN and V12/UN contactors



**N.B.** The drawing gives a general indication of the enclosure dimensions. The overall dimensions and assembly details of the metalwork parts are given in detail in the document ABB TN 10460.

This drawing can be requested in advance of the supply, to allow preparation of the switchgear completion metalwork parts.



## ELECTRIC CIRCUIT DIAGRAM

Diagram of accessories for contactors with electrical latching	68
Diagram of accessories for contactors with mechanical latching	70
State of operation shown	72
Caption	72
Description of figures	72
Notes	72
Graphic symbols for electric diagrams	73

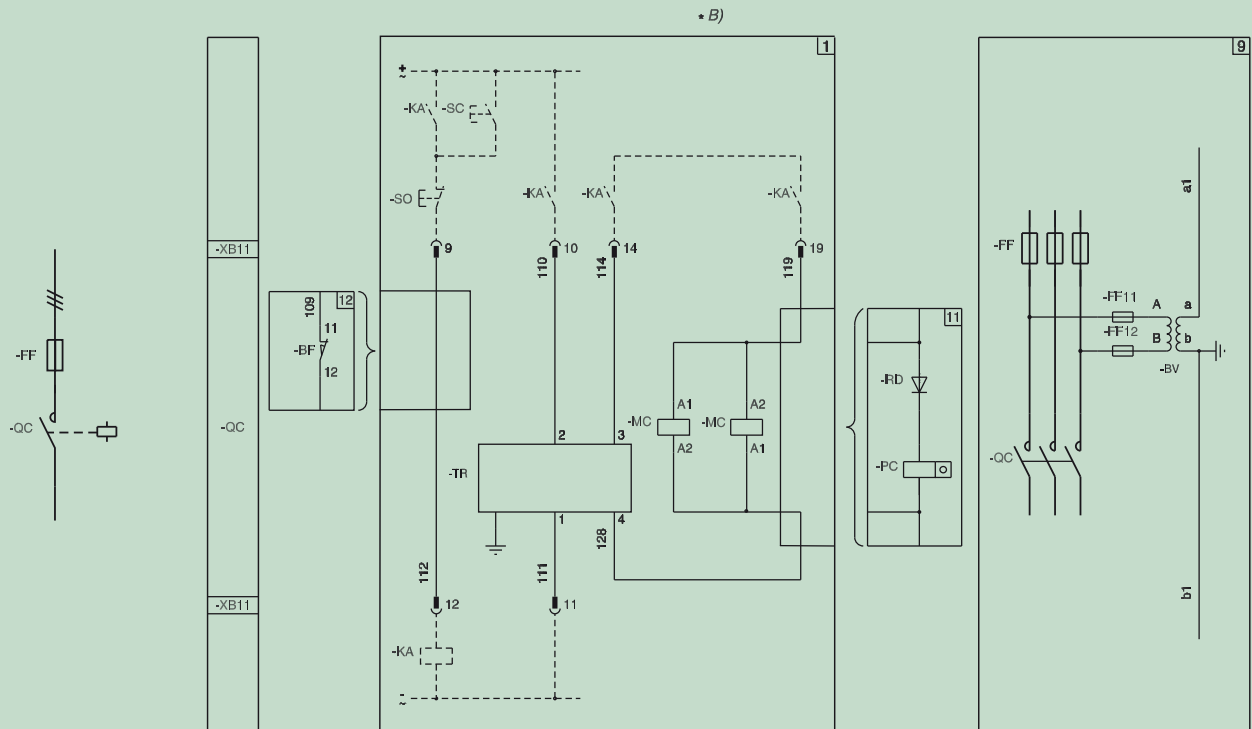
## ELECTRIC CIRCUIT DIAGRAM

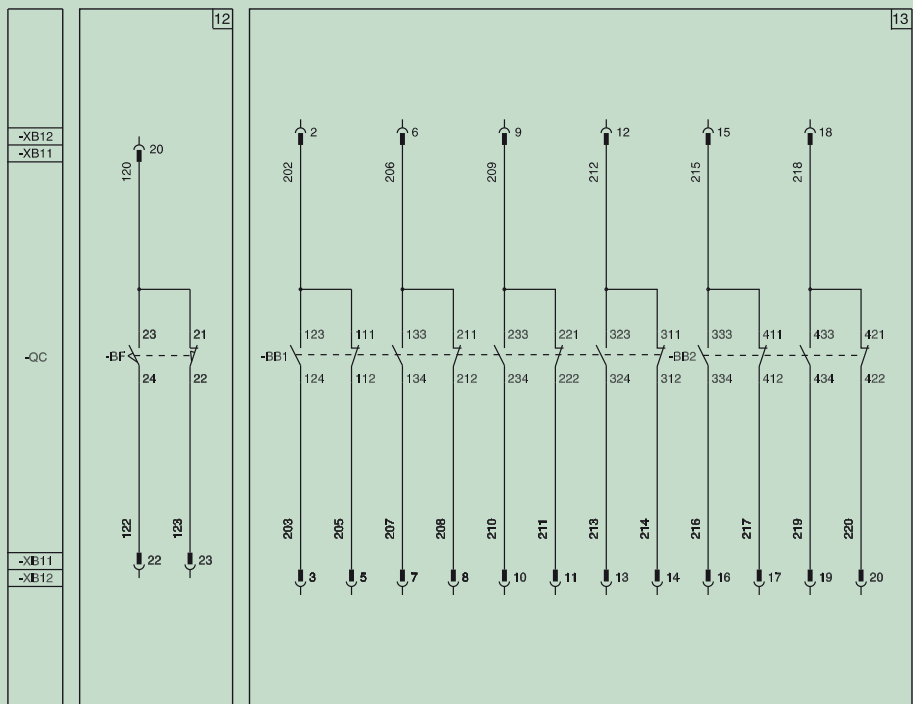
### Diagram of accessories for contactors with electrical latching

As an example, the diagram below shows the circuits of the fixed contactor with electrical latching.

For withdrawable version contactors, ask for the specific electric diagrams.

In any case, to take into account product evolution, it is useful to refer to the circuit diagram supplied with each piece of apparatus.





## ELECTRIC CIRCUIT DIAGRAM

### Diagram of accessories for contactors with mechanical latching

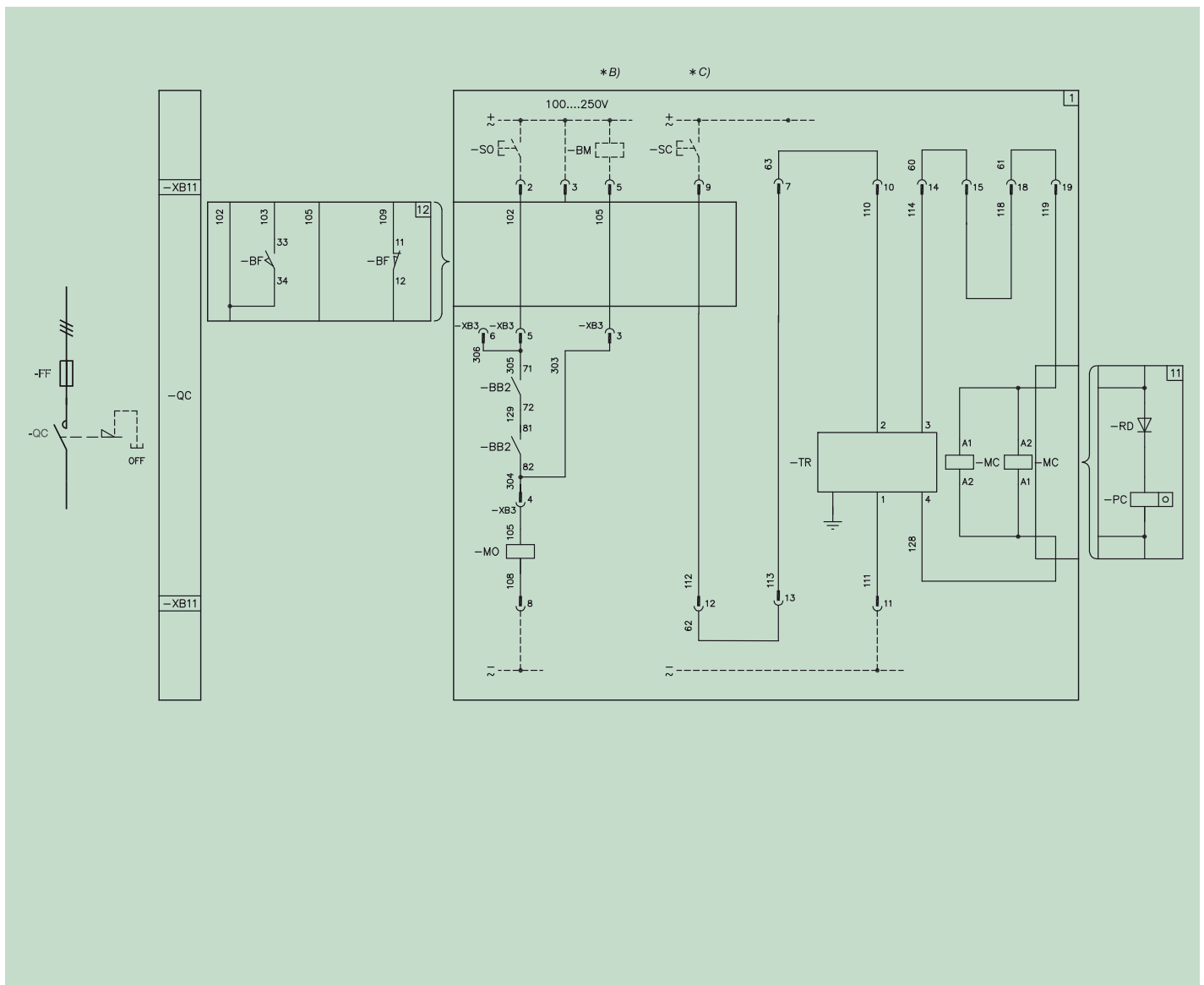
As an example, the diagram below shows the circuits of the fixed contactor with mechanical latching.

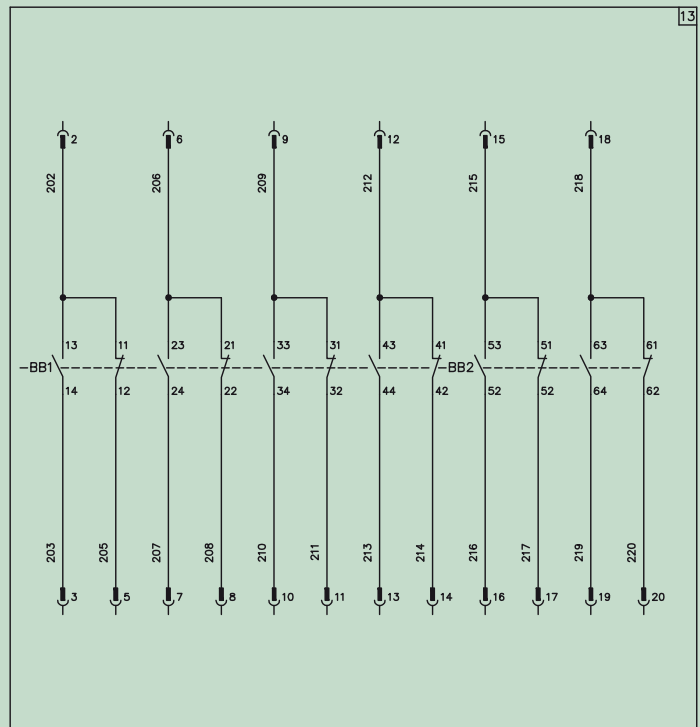
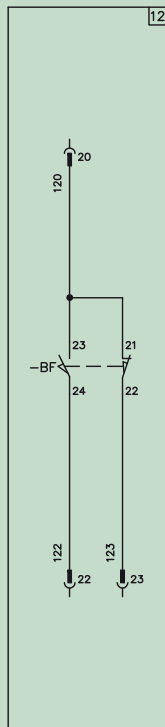
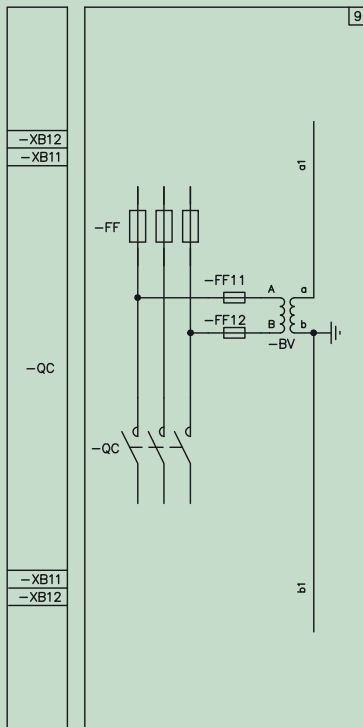
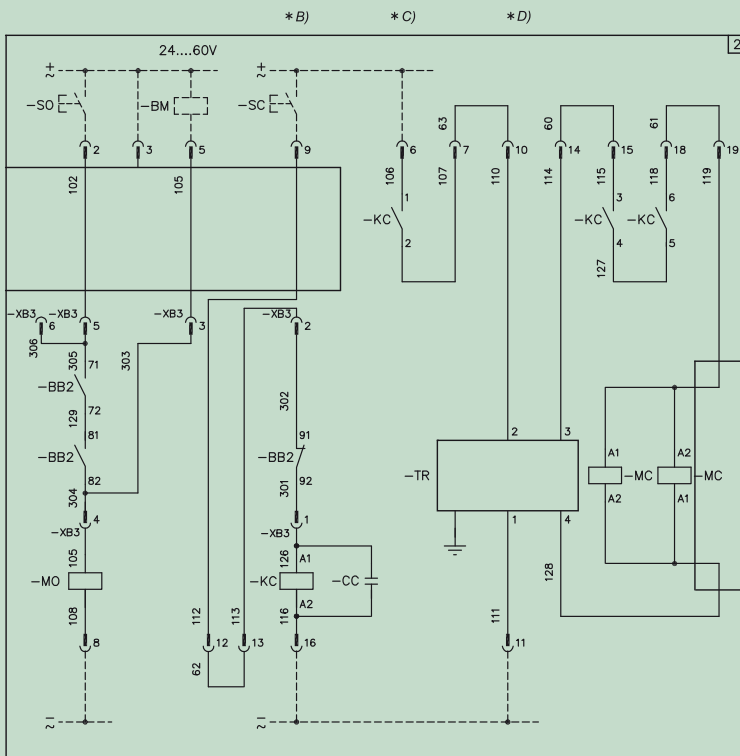
For withdrawable version contactors, ask for the specific electric diagrams.

The anti-pumping function is incorporated in the contactor for auxiliary supply voltage 100-250 V (voltage feeder type 2); for versions with auxiliary supply voltage 24-60 V dc, it is necessary to work on the supply side of the apparatus.

For this purpose, on request electric diagram 1VCD400045 is available.

In any case, to take into account product evolution, it is useful to refer to the circuit diagram supplied with each piece of apparatus.





## ELECTRIC CIRCUIT DIAGRAM

### State of operation shown

The diagram is shown in the following conditions:

- contactor open
- circuits de-energized
- medium voltage fuses not blown.

### Caption

- = Reference number of diagram figure
- TR = Feeder (see note B for contactor with electrical latching; see note D for contactor with mechanical latching).
- BM = Device for checking continuity of the shunt opening release winding (see note B for contactor with mechanical latching)
- CC = Capacitor
- FF = Medium voltage fuses
- FF11, -FF12 = Fuses for voltage transformer protection
- KA = Relay or auxiliary control contactor (use ABB B16 or BC16 type contactor or equivalent apparatus)
- QC = Contactor
- MC = Closing electromagnet
- BB1, -BB2 = Contactor auxiliary contacts
- KC = Auxiliary closing relay (see note C)
- BF = Position contacts of the medium voltage fuses
- SC = Pushbutton or contact for closing contactor
- SO = Pushbutton or contact for opening contactor
- BV = Voltage transformer
- RD = Diode
- XB11, -XB12 = Connectors for contactor circuits
- XB3 = Connectors of the accessories
- PC = Electric operation counter
- MO = Shunt opening release with possibility of continuous control of the winding for contactors with mechanical latching (see note B).

### Description of figures

- Fig. 1 = Contactor control circuits (see note B for contactor with mechanical latching).
- Fig. 2 = Control circuits of the contactor (24/60 V) (with mechanical latching).
- Fig. 9 = Voltage transformer for contactor control circuit power supply.
- Fig. 11 = Electric operation counter circuit.
- Fig. 12 = Medium voltage fuse auxiliary contacts for contactor operating mechanism (cause contactor opening and prevent closure due to a fuse missing or blown) and for signalling.
- Fig. 13 = Contactor auxiliary contacts.

### Notes

- A) The contactor is only fitted with the accessories listed in the order confirmation. To draw up the order, consult this catalogue.

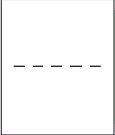
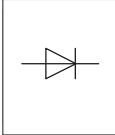
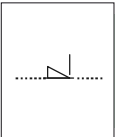
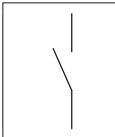
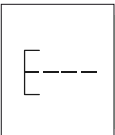
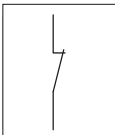
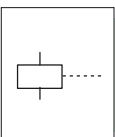
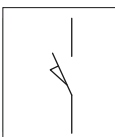

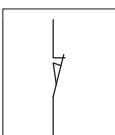
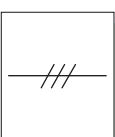
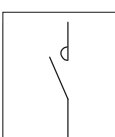
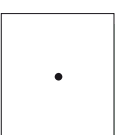
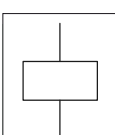
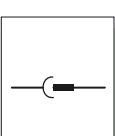
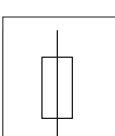
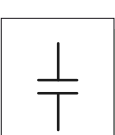
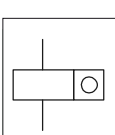
#### **Only for contactor with electrical latching**

- B) In case of power supply voltage between 24 and 60 V DC, the feeder circuits (connections to sockets 10, 11, 14 and 19 of connector -XB11) must be made with 2.5 mm<sup>2</sup> cross-section conductors.

#### **Only for contactor with mechanical latching**

- B) The circuit for control of shunt opening release coil continuity must only be used for this function (e.g.: to connect the "Control Coil Continuity" device or a relay or a signalling lamp absorbing a current no higher than 20mA). Other uses jeopardise integrity of the release.
- C) To carry out the antipumping function, see diagram 1VCD400045.
- D) In case of power supply voltage between 24 and 60 V DC, the feeder circuits (connections to sockets 6 and 11 of connector -XB11) must be made with 2.5 mm<sup>2</sup> cross-section conductors.

## Graphic symbols for electric diagrams (IEC 617 and CEI 3-14 ... 3-26 Standards)

	Mechanical, pneumatic or hydraulic connection		Semiconductor diode (general symbol)
	Latching device, released		Make contact
	Pushbutton control		Break contact
	Electromagnetic control		Closing position contact (limit switch)
	Earth (general symbol)		Opening position contact (limit switch)
	Three conductors		Contactor (make contact)
	Conductor connection or terminal		Control coil (general symbol)
	Socket and plug (female and male)		Fuse (general symbol)
	Capacitor (general symbol)		Electric impulse meter





# Contact us

## **ABB S.p.A.**

### **Power Products Division Unità Operativa Sace-MV**

Via Friuli, 4

I-24044 Dalmine

Tel.: +39 035 6952 111

Fax: +39 035 6952 874

e-mail: [sacetms.tipm@it.abb.com](mailto:sacetms.tipm@it.abb.com)

**[www.abb.com](http://www.abb.com)**

## **ABB Calor Emag Mittelspannung GmbH**

Oberhausener Strasse 33                      Petzower Strasse 8

D-40472 Ratingen                              D-14542 Glindow

Phone: +49(0)2102/12-1230, Fax: +49(0)2102/12-1916

E-mail: [calor.info@de.abb.com](mailto:calor.info@de.abb.com)

**Internet:**<http://www.abb.de/calor>

The data and illustrations are not binding. We reserve the right to make changes without notice in the course of technical development of the product.

Copyright 2009 ABB.  
All rights reserved.