



# AMVAC™ technical guide

## Vacuum circuit breaker with magnetic actuator mechanism

## Universal applications:

- Medium voltage motor starting applications
- Capacitor switching
- Retrofit applications to replace existing circuit breakers in repetitive duty applications

AMVAC circuit breakers have been fully tested to the most recent versions of ANSI C37.04, C37.06, and C37.09. Using "k" factor equals 1 as the test criteria.

Available for 5, 8.25, 15 kV, and 27 kV applications, in stationary and drawout forms, this next generation circuit breaker offers solutions for many applications.

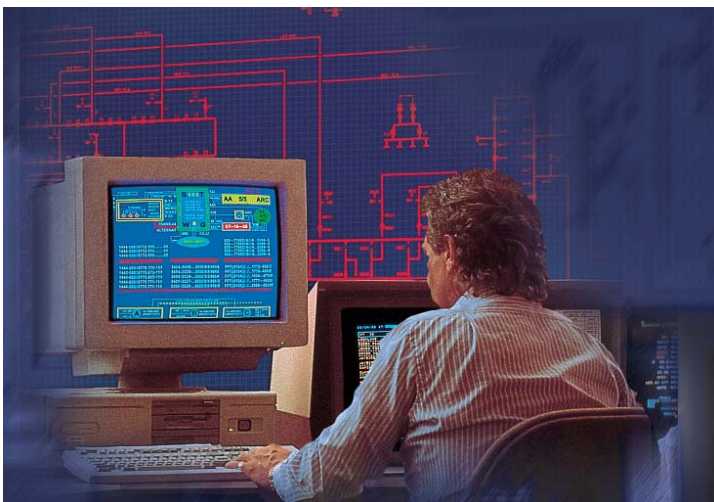
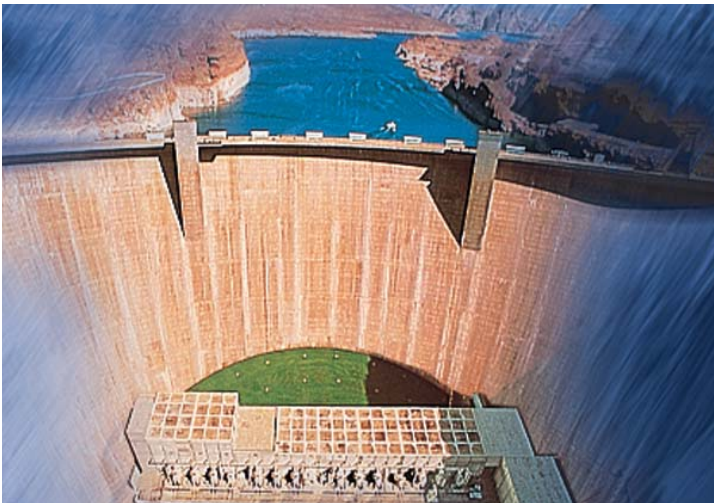

# AMVAC. The circuit breaker.

Although many refinements have been made throughout the 80-90 year history of the medium voltage circuit breaker, there have been only four generations of circuit breaker design. Early circuit breakers were spring charged units with separate close and trip springs. These units were used for older air-magnetic breakers. The second generation used the same mechanism modified for use with a vacuum bottle. The new generation of circuit breakers, such as the ADVAC breaker with a torroidal spring, were designed specifically for use with vacuum technology.

Each generation reflects the best technology available at the time of their introduction, building on the strengths of previous designs, yet adding new innovations, marking true turning points.

Although it is well established that vacuum interrupters are capable of more than 10,000 operations, conventional stored energy circuit breakers seldom operate beyond 10,000 operations without teardown, re-lubrication, and/or replacement of parts. More than 100 parts are required to perform spring charging, closing, anti-pumping and tripping functions. Conventional stored energy breakers also place limitations on the types of control voltages allowed. Vacuum interrupters were mounted in open moldings, making them susceptible to dust, moisture, and corrosive atmospheres.

The AMVAC is truly the next generation in medium voltage vacuum technology. With the AMVAC, ABB is the first to combine the unique requirements of vacuum interrupter technology to a stored energy mechanism designed to exploit these capabilities. Using a flux-shifting device with integral permanent magnets, the AMVAC mechanism has just seven moving parts. Having only an open/close actuator, an electronic controller, and capacitors for energy storage, the AMVAC circuit breaker actuator is capable of 50,000 to 100,000 operations. Vacuum interrupters are embedded in a proprietary epoxy material, achieving excellent dielectric and thermal capabilities. Eliminating mechanism operated cell switches, the AMVAC breaker packages all auxiliary control contacts on the circuit breaker. These are just a few of the features that mark a departure from the conventional stored energy breaker and introduce new capabilities and benefits for the modern power systems.



## Summary of benefits:

- Simple mechanical operation
- Fewer than ten moving parts
- Manual opening capability
- High reliability

The magnetic actuator, encapsulated vacuum interrupter pole assemblies, electronic controller, capacitors, and membrane push button assembly are the key components for this next generation product. The magnetic actuator has a magnetic frame assembly, two identical operating coils, two rare earth magnets, and a single moving armature. Instead of mechanical assemblies for armature position sensing, proximity sensors detect armature position for the electronic controller. The rare earth magnets are especially encapsulated to eliminate the corrosion normally associated with this type of magnet. Evaluation confirms that these permanent magnets will retain 99 percent of their flux density for over 100 years.

Similar evaluations find that the capacitors used for stored energy have a lifetime up to 20 years. These special capacitors charge in as little as seven seconds after control power is available and are periodically “topped off” by the electronic controller as needed. Covers over the capacitor terminals prevent accidental contact.

The AMVAC circuit breaker is designed to provide many years of trouble free service for the end user.

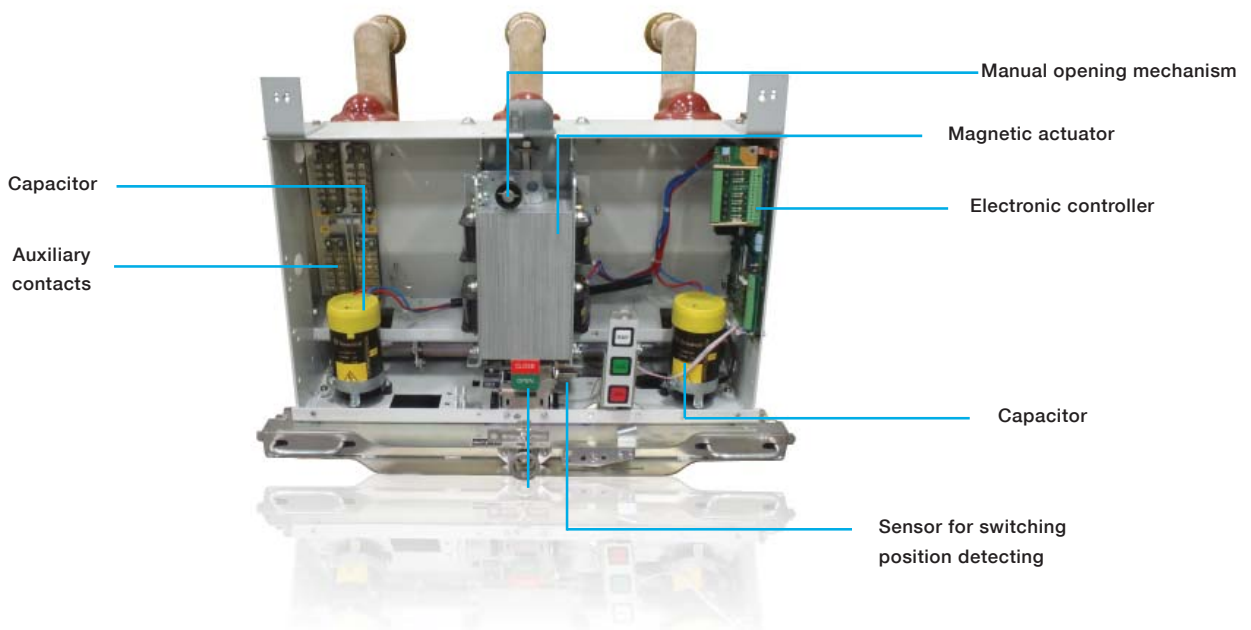

# AMVAC. Qualities that convince.

Innovation extends to the vacuum interrupter assembly, as well. For the first time in any vacuum circuit breaker, the interrupter and the current carrying parts are completely embedded in a proprietary epoxy resin. Thermal performance of the interrupter is improved as the epoxy resin draws heat away from hot spots for a more even heat distribution. Moreover, the interrupter pole assembly is fully skirted so that push rod and other moving

parts of the current transfer area are isolated and protected from external influences. As a result, accumulations of dust, dirt, and condensation do not increase tracking and partial discharge as they do in non-embedded designs.

## Maintenance free vacuum interrupter and current carrying parts in one embedded assembly

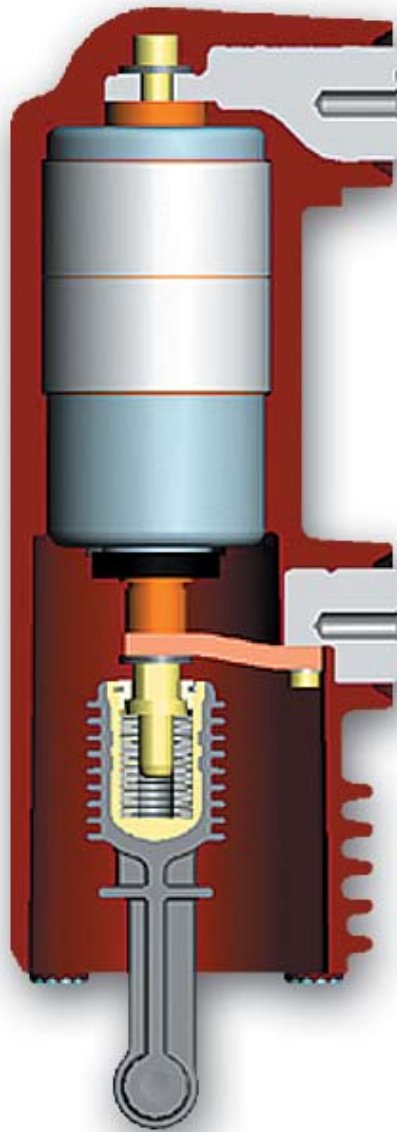

# AMVAC. Low maintenance permanent magnet technology.

Following the advance of vacuum interruption in the field of medium voltage circuit breakers in the last 20 years, a natural teaming of technology has been achieved with the addition of magnetic actuator technology. The requirements of one technology are optimally matched by the opportunities of the other. Magnetic actuator technology naturally provides the suitable travel-time and force-travel characteristics for the vacuum switching devices. All operating mechanism functions are integrated in the magnetic actuator of the AMVAC circuit breaker. The actuator is a bi-stable magnet system, in which armature change-of-state is accomplished by the magnetic field of two electrically excited coils.

The armature is held magnetically in the limit positions by the fields of two rare-earth permanent magnets. Switching operations are achieved by excitation of one of the two coils until the retaining force of the permanent magnets is exceeded. Even on complete failure of auxiliary power, electrical operation is still possible for a period of 60 to 90 seconds. When capacitor stored energy is no longer sufficient to achieve tripping, the circuit breaker can then be opened with the assistance of a manual opening handle. The armature of the magnetic actuator is linked to an operating shaft connected via insulated push rods to each of the vacuum interrupters. The only points of lubrication for this mechanism are at the union of the armature to the operating shaft, the pivot points of the operating shaft, and the pivot points of the operating shaft to the push rods. Long life synthetic lubricants are applied during assembly to further reduce the need for lubrication during the life of the circuit breaker. During circuit breaker racking, mechanical interlocks from the racking mechanism block the movement of the magnetic actuator armature so that the circuit cannot be closed electrically in any racking position other than “test” or “connect”.

## Instantaneous representation of magnetic flux density distribution

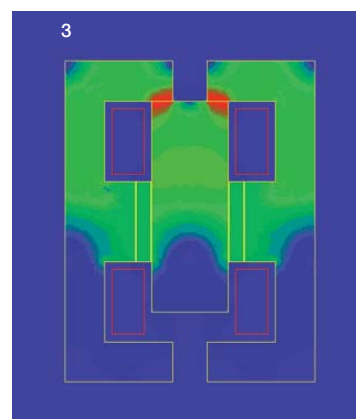
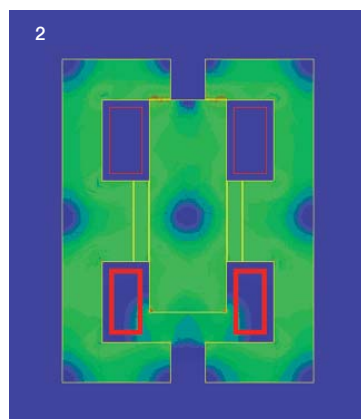
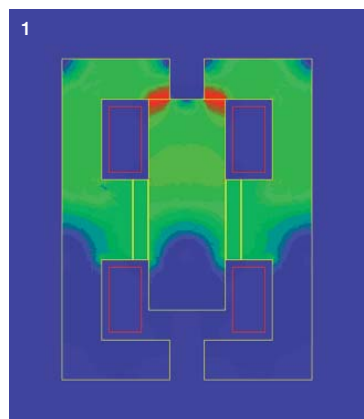

1 Magnetic latching in a limit position. | 2 Magnetic latching plus current build up in one coil. | 3 Armature reaching the opposite limit position.

# AMVAC. Circuit-breaker of the high tech generation.



Proximity sensors provide highly reliable armature position information to the electronic controller.

The electronic controller uses robust components and circuit board conforming coatings to prolong the life of the device. The electronic controller will operate on AC or DC control power because it utilizes an AC to DC converter internally. Instead of selecting from a long list of control power options, the user only needs to select a controller for low voltage control power (38-56 VDC) or a controller for high voltage control power (104-254 VAC or 100-250 VDC). Inside these ranges, the user may apply any value of direct current, or any value of 50 or 60 cycle alternating current to achieve circuit breaker operation. The electronic controller incorporates all capacitor charging, open/close coil switching, anti-pumping, interlocking, and armature

position details. Self-monitoring functions are programmed to monitor proximity sensors, the microprocessor, and other key functions with annunciation and/or circuit breaker opening possible. Radio frequency and transient testing has been performed on the electronic controller to ensure that it is resistant to such abnormal conditions. The electronic controller demands up to 100 watts of peak power during capacitor charging; less than 10 watts of power is needed to maintain 10 amperes peak during capacitor charging; only four watts of energy is needed to maintain controller functions and capacitor full charge.

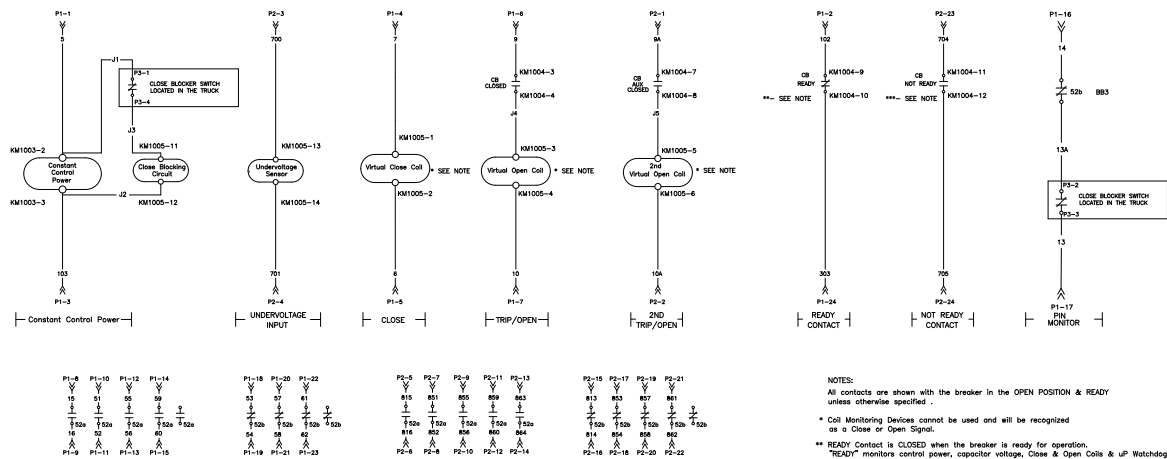

# AMVAC. Technical data.

**Table 1. Short circuit ratings**

Voltage Class	FLC (Amps)	Isc (kA)	Type/Rating	Max. Wave voltage (kV, rms)	Max. Sym. Interrupt & STC (kA, rms)	Close & Latch (kA, rms)	Lightning Impulse Withstand (BiL) (kV, Crest)	Low Frequency Withstand (Hi-Pot) (kV, rms)
5	1200	25	AMVAC 05.12.25	4.76	25	65	60	19
		31.5	AMVAC 05.12.31	4.76	31.5	82	60	19
		40	AMVAC 05.12.40	4.76	40	104	60	19
		50	AMVAC 05.12.50	4.76	50	130	60	19
	2000	25	AMVAC 05.20.25	4.76	25	65	60	19
		31.5	AMVAC 05.20.31	4.76	31.5	82	60	19
		40	AMVAC 05.20.40	4.76	40	104	60	19
		50	AMVAC 05.20.50	4.76	50	130	60	19
	3000	25	AMVAC 05.30.25	4.76	25	65	60	19
		31.5	AMVAC 05.30.31	4.76	31.5	82	60	19
		40	AMVAC 05.30.40	4.76	40	104	60	19
		50	AMVAC 05.30.50	4.76	50	130	60	19
8.25	1200		AMVAC 08.12.40	8.25	40	104	95	36
	2000	40	AMVAC 08.20.40	8.25	40	104	95	36
	3000		AMVAC 08.30.40	8.25	40	104	95	36
15	1200	20	AMVAC 15.12.20	15	20	52	95	36
		25	AMVAC 15.12.25	15	25	65	95	36
		31.5	AMVAC 15.12.31	15	31.5	82	95	36
		40	AMVAC 15.12.40	15	40	104	95	36
		50	AMVAC 15.12.50	15	50	130	95	36
	2000	20	AMVAC 15.20.20	15	20	52	95	36
		25	AMVAC 15.20.25	15	25	65	95	36
		31.5	AMVAC 15.20.31	15	31.5	82	95	36
		40	AMVAC 15.20.40	15	40	104	95	36
		50	AMVAC 15.20.50	15	50	130	95	36
	3000	20	AMVAC 15.30.20	15	20	52	95	36
		25	AMVAC 15.30.25	15	25	65	95	36
		31.5	AMVAC 15.30.31	15	31.5	82	95	36
		40	AMVAC 15.30.40	15	40	104	95	36
		50	AMVAC 15.30.50	15	50	130	95	36
27	1200	16	AMVAC 27.12.16	27	16	42	125	60
		25	AMVAC 27.12.25	27	25	65	125	60
	2000	16	AMVAC 27.20.16	27	16	42	125	60
		25	AMVAC 27.20.25	27	25	65	125	60

**Table 2. Capacitor bank switching ratings**

Voltage Class	FLC (Amps)	Isc (kA)	Type/Rating	Max. Sym. Interrupt & STC (kA, rms)		Capacitor Switching Ratings
5	1200	25	AMVAC 05.12.25	25	C2	630A C2 rated 15kA Peak 2.0 Khz
		31.5	AMVAC 05.12.31	31.5	C1	Rated cable charging current 10A
		40	AMVAC 05.12.40	40	C1	Rated cable charging current 10A
		50	AMVAC 05.12.50	50	C2	630A C2 rated 15kA Peak 2.0 Khz
	2000	25	AMVAC 05.20.25	25	C1	Rated cable charging current 10A
		31.5	AMVAC 05.20.31	31.5	C1	Rated cable charging current 10A
		40	AMVAC 05.20.40	40	C2	1200A C2 rated 15kA Peak 2.0 Khz
		50	AMVAC 05.20.50	50	C2	1200A C2 rated 15kA Peak 2.0 Khz
	3000	25	AMVAC 05.30.25	25	C2	1200A C2 rated 15kA Peak 2.0 Khz
		31.5	AMVAC 05.30.31	31.5	C2	1200A C2 rated 15kA Peak 2.0 Khz
		40	AMVAC 05.30.40	40	C2	1200A C2 rated 15kA Peak 2.0 Khz
		50	AMVAC 05.30.50	50	C2	1000A C2 rated 15kA Peak 2.0 Khz
8.25	1200		AMVAC 08.12.40	40	C2	1200A C2 rated 15kA Peak 2.0 Khz
	2000	40	AMVAC 08.20.40	40	C2	1200A C2 rated 15kA Peak 2.0 Khz
	3000		AMVAC 08.30.40	40	C2	1200A C2 rated 15kA Peak 2.0 Khz
15	1200	20	AMVAC 15.12.20	20	C2	630A C2 rated 15kA Peak 2.0 Khz
		25	AMVAC 15.12.25	25	C2	630A C2 rated 15kA Peak 2.0 Khz
		31.5	AMVAC 15.12.31	31.5	C1	Rated cable charging current 10A
		40	AMVAC 15.12.40	40	C2	1200A C2 rated 15kA Peak 2.0 Khz
		50	AMVAC 15.12.50	50	C2	630A C2 rated 15kA Peak 2.0 Khz
	2000	20	AMVAC 15.20.20	20	C1	Rated cable charging current 25A
		25	AMVAC 15.20.25	25	C1	Rated cable charging current 25A
		31.5	AMVAC 15.20.31	31.5	C1	Rated cable charging current 25A
		40	AMVAC 15.20.40	40	C2	1200A C2 rated 15kA Peak 2.0 Khz
		50	AMVAC 15.20.50	50	C2	1000A C2 rated 15kA Peak 2.0 Khz
	3000	20	AMVAC 15.30.20	20	C2	1200A C2 rated 15kA Peak 2.0 Khz
		25	AMVAC 15.30.25	25	C2	1200A C2 rated 15kA Peak 2.0 Khz
31.5		AMVAC 15.30.31	31.5	C2	1200A C2 rated 15kA Peak 2.0 Khz	
40		AMVAC 15.30.40	40	C2	1200A C2 rated 15kA Peak 2.0 Khz	
50		AMVAC 15.30.50	50	C2	1000A C2 rated 15kA Peak 2.0 Khz	
27	1200	16	AMVAC 27.12.16	16	C2	400A C2 rated 20 kA Peak 4.4 Khz
		25	AMVAC 27.12.25	25	C2	400A C2 rated 20 kA Peak 4.4 Khz
	2000	16	AMVAC 27.20.16	16	C2	400A C2 rated 20 kA Peak 4.4 Khz
		25	AMVAC 27.20.25	25	C2	400A C2 rated 20 kA Peak 4.4 Khz

**Table 3. Timing characteristics:**

Voltage Class	FLC (Amps)	Isc (kA)	Type/Rating	Interrupt Time (cycles)	Opening time		Closing time
					(ms) 3 cycles	(ms) 5 cycles	
5	1200	25	AMVAC 05.12.25	3	27.5-32.5	N.A.	30-60
		31.5	AMVAC 05.12.31	3	11.8-28.7	N.A.	30-60
		40	AMVAC 05.12.40	5	N.A.	62.67-72.1	50-80
		50	AMVAC 05.12.50	5	N.A.	62.67-70.2	50-80
	2000	25	AMVAC 05.20.25	3	11.8-28.7	N.A.	30-60
		31.5	AMVAC 05.20.31	3	11.8-28.7	N.A.	30-60
		40	AMVAC 05.20.40	5	29.1-31.3	62.67-73	50-80
		50	AMVAC 05.20.50	5	N.A.	62.67-70.2	50-80
	3000	25	AMVAC 05.30.25	5	29.1-31.3	62.67-73	50-80
		31.5	AMVAC 05.30.31	5	29.1-31.3	62.67-73	50-80
		40	AMVAC 05.30.40	5	29.1-31.3	62.67-73	50-80
		50	AMVAC 05.30.50	5	N.A.	62.67-70.2	50-80
8.25	1200		AMVAC 08.12.40	5	29.1-31.3	62.67-73	50-80
	2000	40	AMVAC 08.20.40	5	29.1-31.3	62.67-73	50-80
	3000		AMVAC 08.30.40	5	29.1-31.3	62.67-73	50-80
15	1200	20	AMVAC 15.12.20	3	27.5-32.5	N.A.	30-60
		25	AMVAC 15.12.25	3	27.5-32.5	N.A.	30-60
		31.5	AMVAC 15.12.31	3	11.8-28.7	N.A.	30-60
		40	AMVAC 15.12.40	5	29.1-31.3	62.67-73	50-80
		50	AMVAC 15.12.50	5	27.97-33.7	62.67-74.3	50-80
	2000	20	AMVAC 15.20.20	3	11.8-28.7	N.A.	30-60
		25	AMVAC 15.20.25	3	11.8-28.7	N.A.	30-60
		31.5	AMVAC 15.20.31	3	11.8-28.7	N.A.	30-60
		40	AMVAC 15.20.40	5	29.1-31.3	62.67-73	50-80
		50	AMVAC 15.20.50	5	27.97-33.7	62.67-74.3	50-80
	3000	20	AMVAC 15.30.20	5	29.1-31.3	62.67-73	50-80
		25	AMVAC 15.30.25	5	29.1-31.3	62.67-73	50-80
		31.5	AMVAC 15.30.31	5	29.1-31.3	62.67-73	50-80
		40	AMVAC 15.30.40	5	29.1-31.3	62.67-73	50-80
		50	AMVAC 15.30.50	5	27.97-33.7	62.67-74.3	50-80
27	1200	16	AMVAC 27.12.16	5	N.A.	39.16-40.83	49.53-52.21
		25	AMVAC 27.12.25	5	N.A.	36.14-40.83	49.2-53.88
	2000	16	AMVAC 27.20.16	5	N.A.	32.7	56.7
		25	AMVAC 27.20.25	5	N.A.	37.48-42.5	50.87-55.22

\*Total interrupting time consists of opening time plus the time required for arc interruption. Total interrupt time is 50 ms or less for 3 cycle breakers and 83 ms or less for 5 cycle breakers. Opening time is defined as the time from when the trip signal is received until primary contacts begin to part.

**Table 4. Mechanical details**

Parameter	5 kV	8.25 kV	15 kV	27 kV
Mechanical operations-mechanism	50,000-100,000	50,000	50,000-100,000	50,000
Mechanical operations-vacuum interrupter	30,000	30,000	30,000	15,000
Operating cycles at rated circuit	30,000	100	30,000	15,000
Operating cycles at short-circuit current	100	100	100	100
Control power at rest	< 10 watts	< 10 watts	< 10 watts	< 10 watts
Control power during capacitor charging	<100 watts	<100 watts	<100 watts	<100 watts
Height (fixed mount) (mm)	25.65" (651.5)	25.65" (651.5)	25.65" (651.5)	27.42" (696.5)
Depth (fixed mount) (mm)	16.93" (429.9)	16.93" (429.9)	16.93" (429.9)	16.93" (429.9)
Width (frame) (mm)	27.56" (700)	NA	27.56" (700)	NA
	29.53" (750) [40-50kA and all 3000 A models]	29.53" (750) [40-50kA and all 3000 A models]	29.53" (750) [40-50kA and all 3000 A models]	29.53" (750)
Weight (drawout) (min/max) lbs (kg)	321.93 (146)	321.93 (146)	321.93 (146)	321.93 (412.34)
	450 (204.1)	450 (204.1)	450 (204.1)	avg"

**Table 5. Auxiliary switch ratings**

Un		Rated current (A)	Breaking capacity (A)
220 VAC		2.5	25
	1 ms	10	12
24 VDC	15 ms	10	12
	50 ms	8	10
	200 ms	6	7.7
	1 ms	8	10
60 VDC	15 ms	6	8
	50 ms	5	6
	200 ms	4	5.4
	1 ms	6	8
110 VDC	15 ms	4	5
	50 ms	2	4.6
	200 ms	1	2.2
	1 ms	1.5	2
220 VDC	15 ms	1	1.4
	50 ms	0.75	1.2
	200 ms	0.5	1
	1 ms	1.5	2

Table 6. Contact resistance

Voltage Class	FLC (Amps)	Isc (kA)	Type/Rating	Contact Resistance <= ( $\mu\Omega$ )
5	1200	25	AMVAC 05.12.25	46.1
		31.5	AMVAC 05.12.31	46.1
		40	AMVAC 05.12.40	35.85
		50	AMVAC 05.12.50	35.85
	2000	25	AMVAC 05.20.25	16.9
		31.5	AMVAC 05.20.31	16.9
		40	AMVAC 05.20.40	16.9
		50	AMVAC 05.20.50	12.93
	3000	25	AMVAC 05.30.25	13.28
		31.5	AMVAC 05.30.31	13.28
		40	AMVAC 05.30.40	13.28
		50	AMVAC 05.30.50	13.28
8.25	1200		AMVAC 08.12.40	35.85
	2000	40	AMVAC 08.20.40	16.9
	3000		AMVAC 08.30.40	13.28
15	1200	20	AMVAC 15.12.20	46.1
		25	AMVAC 15.12.25	46.1
		31.5	AMVAC 15.12.31	46.1
		40	AMVAC 15.12.40	35.85
		50	AMVAC 15.12.50	12.93
	2000	20	AMVAC 15.20.20	16.9
		25	AMVAC 15.20.25	16.9
		31.5	AMVAC 15.20.31	16.9
		40	AMVAC 15.20.40	16.9
		50	AMVAC 15.20.50	12.93
	3000	20	AMVAC 15.30.20	13.28
		25	AMVAC 15.30.25	13.28
		31.5	AMVAC 15.30.31	13.28
		40	AMVAC 15.30.40	13.28
		50	AMVAC 15.30.50	12.51
27	1200	16	AMVAC 27.12.16	19.69
		25	AMVAC 27.12.25	17.66
	2000	16	AMVAC 27.20.16	12.7
		25	AMVAC 27.20.25	12.58

# AMVAC. The modern circuit breaker.

## The equipment specifications:

- Completely concealed moving parts
- UL Labeling and CSA compliance
- Low Power consumption
- ANSI compliance at 5, 8.25, 15 kV and 27 kV

## The following are standard features of the AMVAC electronic controller:

- Undervoltage trip
- Trip on loss of stored energy

The AMVAC circuit breaker is shipped with these standard features disabled; the end user may enable the features he chooses by moving the appropriate 'dip' switch to the 'on' position.

## The following electronic controller 'dry contact' (250 VAC and VDC, 200 mA) outputs wired to the circuit breaker secondary disconnects are optional at extra cost:

- A normally open contact that closes when the capacitors are fully charged to provide external 'Ready' indication.
- A normally closed contact that opens when the capacitors are not fully charged to provide external 'Not Ready' indication.
- A normally open contact that closes for 100 ms to indicate a trip signal was received by the microprocessor.

- Two normally open 'a' contacts which close when the circuit breaker is closed plus two normally closed 'b' contacts which open when the circuit breaker is closed.
- Close blocker function that prevents circuit breaker closing unless a control power signal (16 - 280 VDC, 104 - 256 VAC) is present at the terminals of the close blocker feature.

The AMVAC is the first vacuum circuit breaker to combine low maintenance embedded vacuum interrupters, a low maintenance magnetic actuator, and a maintenance-free electronic controller. The result is a medium voltage circuit breaker capable of 100,000 operations.

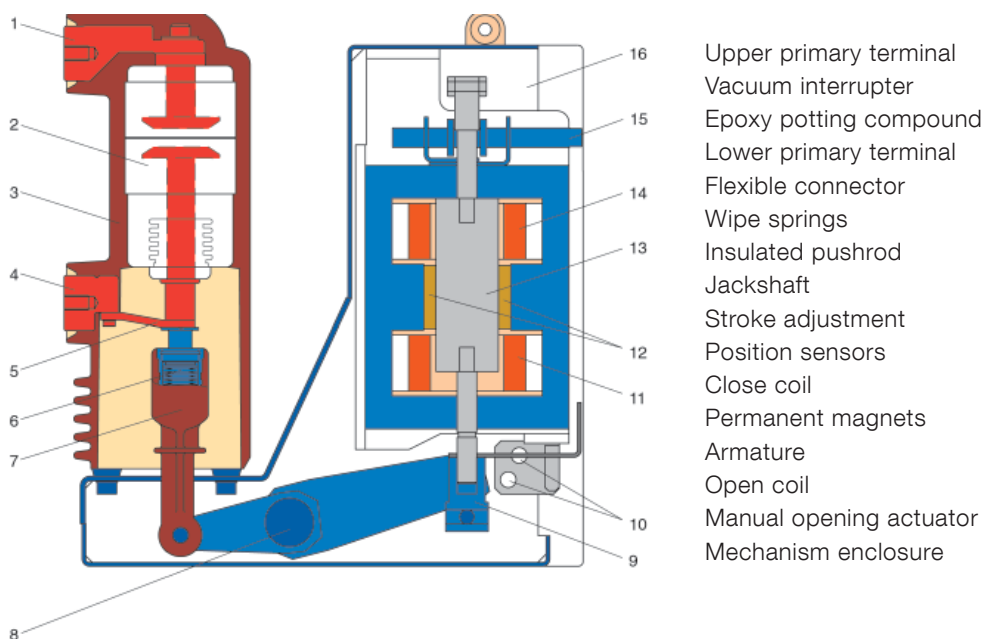

# AMVAC. Circuit breaker specifier's guide.

## General

The circuit breaker shall be an ABB AMVAC or approved equal, three-pole, drawout (or stationary) type, electrically operated with stored energy magnetic actuator operating mechanism. The circuit breaker is intended for use as a general purpose device in accordance with the latest revisions of the following ANSI standards applying to 5, 8.25, 15, or 27 kV applications: ANSI C37.04, C37.06, and C37.09.

### Drawout circuit breaker racking system and interlocks

The circuit breaker shall be inserted and withdrawn by means of a breaker mounted racking system, which can be operated with the compartment door open or closed. The racking system shall provide smooth consistent racking, and shall secure the breaker from both sides of the cell in all racking positions. During racking, the breaker shall automatically open and close cell-mounted safety shutters to cover stationary primary contacts when the breaker is not in the "Connected" position.

The racking system shall have three distinct positions. In addition to the withdrawn position (free movement): "Disconnected" (both primary and secondary contacts disengaged), "Test" (secondary contacts engaged, primary contacts disconnected, and shutter closed), and "Connected" (Shutter open, primary and secondary contacts engaged). Positive stops shall be provided for all three positions, with deliberate operator intervention required to enable continued insertion or withdrawal of the circuit breaker from any position.

The racking system and all moving parts of the breaker-cell interface, including the secondary disconnects, shutter actuator and ground contact, shall be capable of 500 complete rack-in/rack-out operations without maintenance.

It shall not be possible to insert or withdraw a closed breaker, and the breaker shall not be allowed to close within a cell unless it is in the "Connected", "Test", or "Disconnected" position. Electrical and mechanical blocking means shall be employed to preclude breaker contact closure in any position other than "Connected", "Test", or "Disconnected".

## Controls

Opening and closing speed shall be independent of the operator or the control voltage within the rated control voltage range. Circuit breaker charge, close, and trip circuits shall be electrically separated, and control voltage for each circuit shall be independently specified from the full range of ANSI preferred control voltages. Provisions shall be provided for manually opening the circuit breaker. These provisions shall be installed and easily accessible at the front of the breaker.

All control components shall be front-accessible for quick inspection after easy removal of the circuit breaker front cover. Mechanism operated cell switches shall not be allowed; the circuit breaker shall include eight on-board auxiliary contacts (four normally open "a" and three normally closed "b") for customer use, wired through the secondary disconnect. All breaker-mounted contacts shall operate in both the "Connected" and "Test" positions.

### Option:

Nine additional contacts (for a total of nine normally open "a" and seven normally closed "b") shall be installed on the circuit breaker and wired through the secondary disconnect, for a total of 17 on-board contacts.

**Option:**

Two normally open 'a' and normally close 'b' contacts located on the electronic controller shall be furnished. These 'dry' contacts change state as the circuit breaker main contacts change state.

The circuit breaker shall have a flag to indicate open or closed position. An indicating light will illuminate when the stored energy system has sufficient energy for circuit breaker change of state. Capacitors are recharged after an open or close operation. During the capacitor charging function, a green 'Ready' indicating light blinks until full capacitor charge; it remains on continuously when full capacitor charge is achieved. Capacitors shall hold their charge for up to 60 to 90 seconds after control power loss. A user-selectable loss of control power trip function shall be offered to provide trip on loss of control power.

**Option:**

Capacitor 'Ready' and 'Not Ready' dry-type contacts shall be provided for monitoring stored energy status by remote SCADA systems.

The circuit breaker shall have a five-digit, non-resetting operation counter clearly visible from the front of the breaker. The operation counter shall advance when the circuit breaker closes. An electronic controller shall be provided for controlling capacitor charging, switching capacitor energy to the closing or opening coils, providing the anti-pumping feature, and a full range of user-selectable functions. Proximity sensors shall be connected to the electronic controller to sense magnetic actuator armature position. The electronic controller shall also incorporate user-selectable instantaneous or time delay undervoltage that trips the circuit breaker when the control power falls to a value that is 30-60 percent of nominal voltage. Electronic controllers shall be universal AC/DC devices allowing either 24 - 60 VAC or VDC or 110 - 250 VAC or VDC control power flexibility. 'Watchdog' functions shall reset the microprocessor automatically to maintain trip and close capability. The electronic controller shall also include a user-selectable function to automatically trip the circuit breaker in response to loss of stored energy.

**Option:**

Electronic controller shall have user-selectable instantaneous and time delay undervoltage that shall cause the circuit breaker to open when the control power falls to a value that is 30-60 percent of the nominal control voltage. Time delays of 0.050, 0.5, 1.0, 2.0, 3.0, 4.0, or 5.0 seconds may be selected.

**Option:**

To prevent unintentional operation of the circuit breaker in the 'Connected' position, the electronic controller shall be equipped with a Close Blocker feature to electronically prevent local or remote actuation of close function.

**Current path**

Each primary lead assembly shall consist of a vacuum interrupter completely embedded in an epoxy resin casting. The epoxy casting shall encapsulate not only the vacuum interrupter, but also the upper and lower current carrying parts and current transfer assembly. The epoxy casting shall limit access to any moving parts, protecting them from dirt and debris. Epoxy encapsulation shall be used on all circuit breakers. Connecting directly to the pole pads, silver-plated copper upper and lower leads shall use tuliptype self-aligning primary disconnects. A dedicated ground contact shall be provided to engage the stationary ground contact in the circuit breaker compartment to ground the circuit breaker in all positions from "Disconnected" through "Connected".

**Maintenance and handling**

The magnetic actuator mechanism shall be front-accessible. No routine lubrication of the magnetic actuator mechanism shall ever be required. Routine inspections shall be performed with the breaker in the upright position. Circuit breakers shall have self-contained wheels designed for easy insertion, removal and transport on flat indoor surfaces.

# AMVAC. Outline drawings.

U (kV)	Ir (A)	Isc (kA)
4.76	1200	25-31.5
15	1200	20-25-31.5

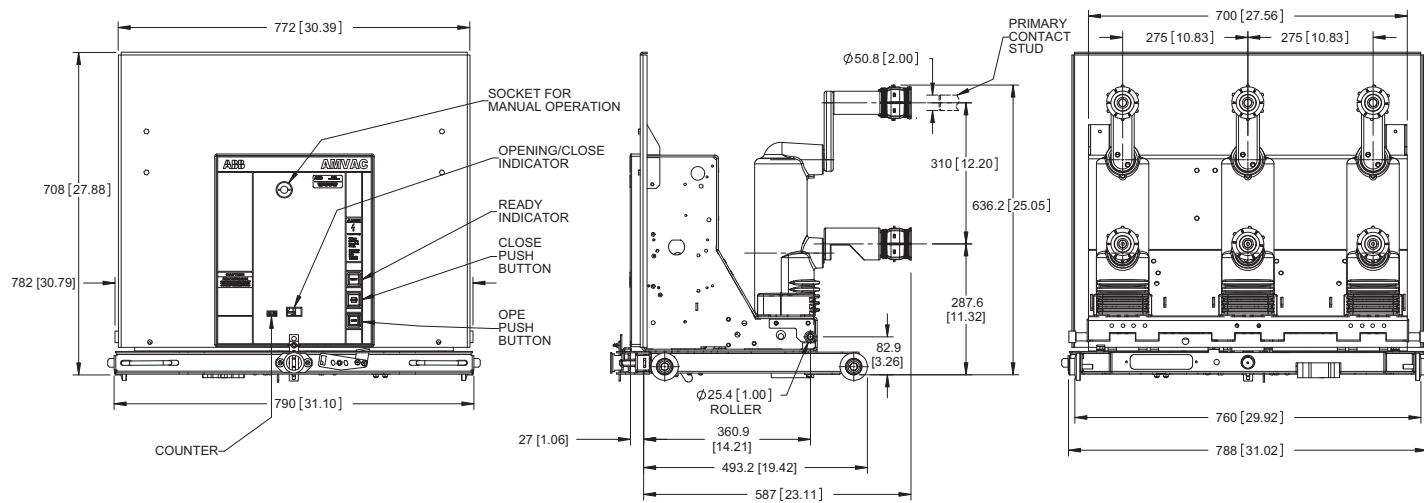

U (kV)	Ir (A)	Isc (kA)
4.76	2000	25-31.5
4.76	2000	40
4.76	2000	50
8.25	2000	40
15	2000	20-25-31.5
15	2000	40

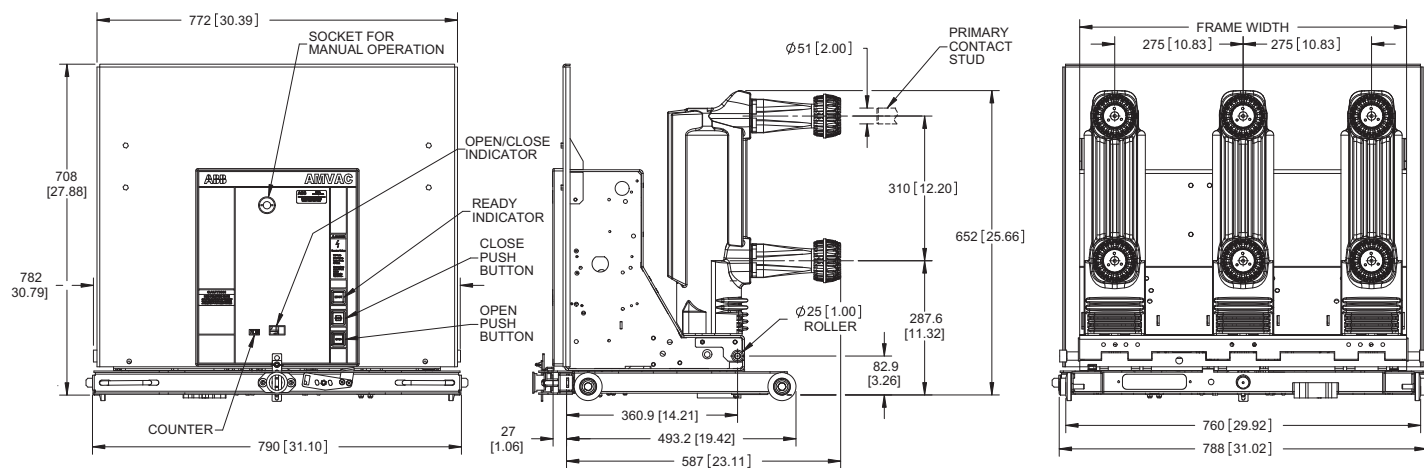

U (kV)	I <sub>r</sub> (A)	I <sub>sc</sub> (kA)
4.76	1200	40
8.25	1200	40
15	1200	40

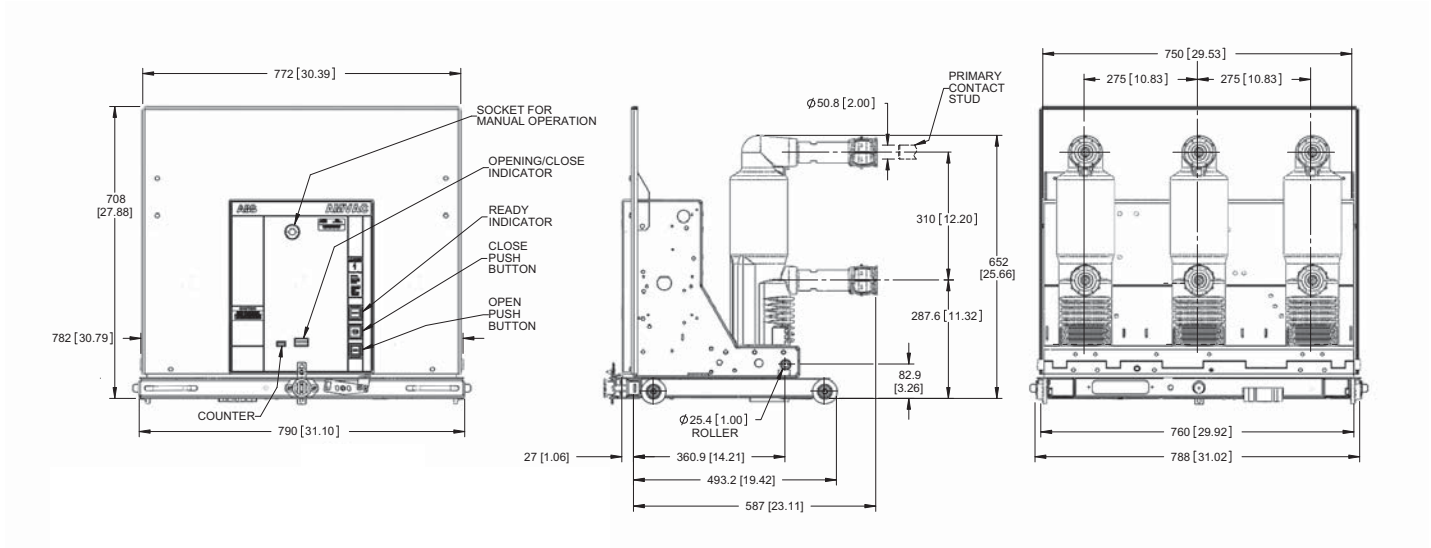

U (kV)	I <sub>r</sub> (A)	I <sub>sc</sub> (kA)
4.76	1200	50

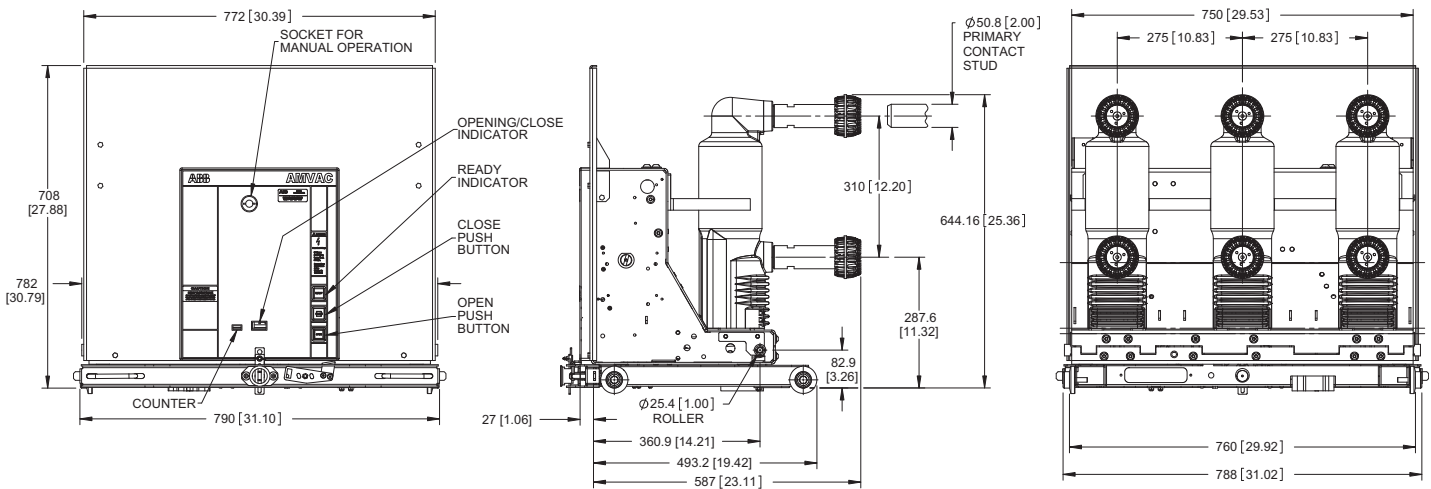

U (kV)	I <sub>r</sub> (A)	I <sub>sc</sub> (kA)
4.76	3000	25-31.5-40
4.76	3000	50
8.25	3000	40
15	3000	20-25-31.5-40

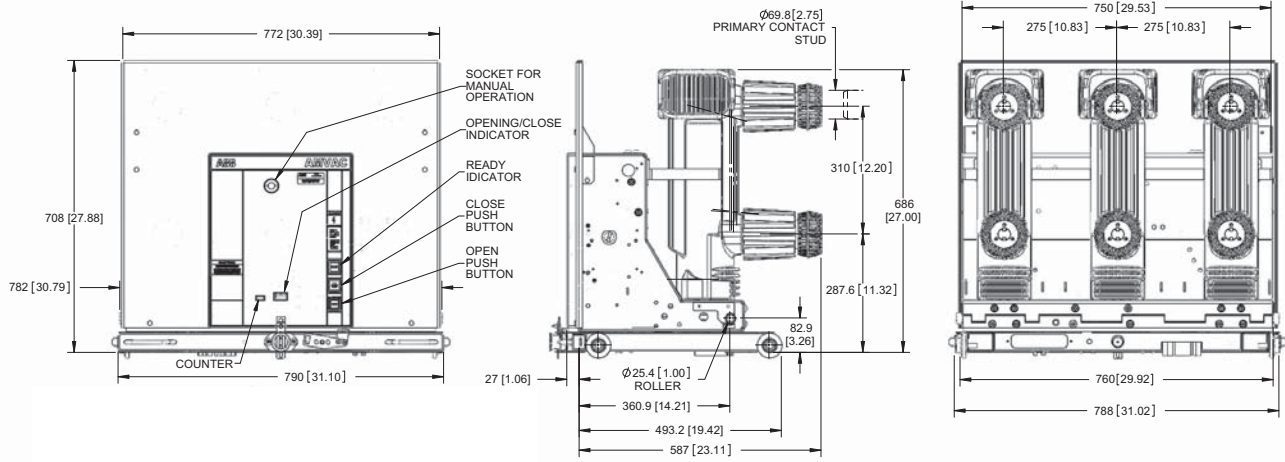

U (kV)	I <sub>r</sub> (A)	I <sub>sc</sub> (kA)
15	1200-2000	50

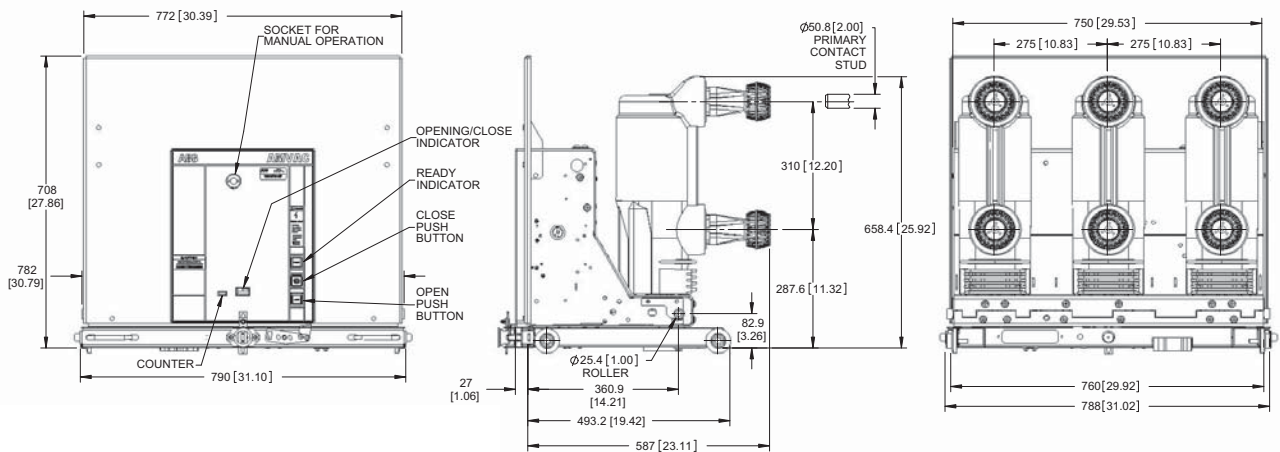

U (kV)	I <sub>r</sub> (A)	I <sub>sc</sub> (kA)
15	3000	50

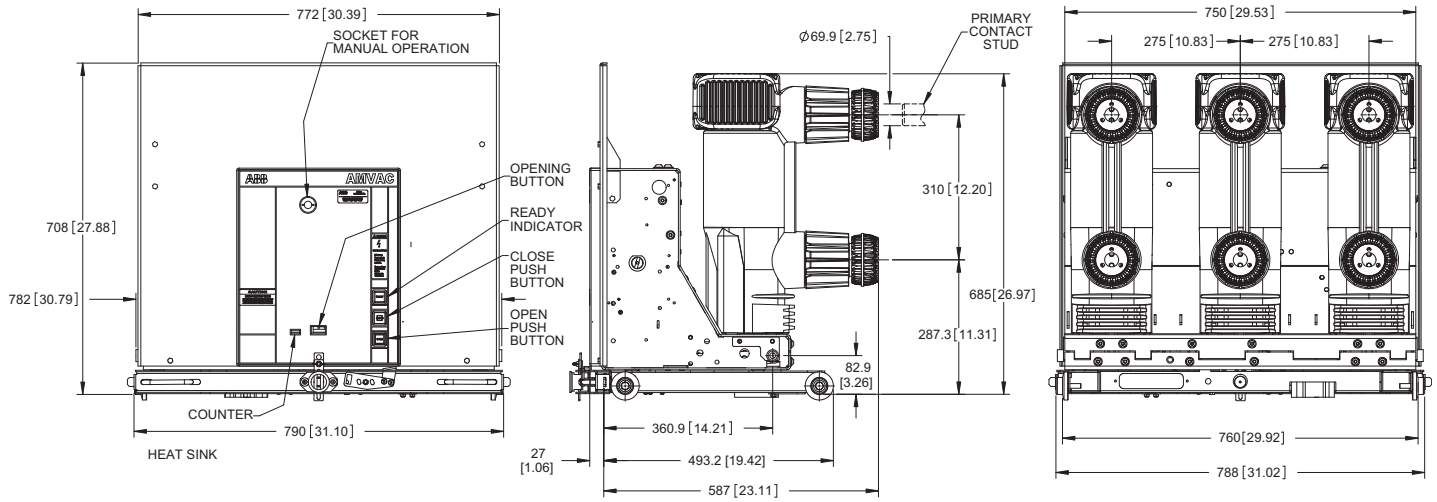

# Contact us

## **ABB Inc.**

### **Medium Voltage OEM Apparatus**

655 Century Point

Lake Mary, FL 32746

Phone: +1 407 732 2000

Customer service: +1 800 929 7947 ext. 5

+1 407 732 2000 ext. 2510

E-Mail: [customer.service.group@us.abb.com](mailto:customer.service.group@us.abb.com)

## **ABB Inc.**

### **Low and Medium Voltage Service**

Florence, South Carolina

Phone: +1 800 HELP 365 (option 7)

+1 407 732 2000

[www.abb.com/mediumvoltage](http://www.abb.com/mediumvoltage)

[www.abb.us/mvservice](http://www.abb.us/mvservice)

#### **Note:**

We reserve the right to make technical changes or modify the contents of this document without prior notice. With regard to purchase orders, the agreed particulars shall prevail. ABB does not accept any responsibility whatsoever for potential errors or possible lack of information in this document. We reserve all rights in this document and in the subject matter and illustrations contained therein. Any reproduction – in whole or in parts – is forbidden without ABB's prior written consent.

Copyright 2010, 2011 ABB.

All rights reserved.