

DCS800-EP Installation and Start Up Manual

DCS800 Panel Drive (20-1000 Amps)
A supplement to the DCS800 Hardware manual



Safety instructions

What this chapter contains

This chapter contains the safety instructions which you must follow when installing, operating and servicing the drive. If ignored, physical injury or death may follow, or damage may occur to the drive, the motor or driven equipment. Read the safety instructions before you work on the unit.

To which products this chapter applies

This chapter applies to the DCS800-EP... Size D1 to D4.

Use of warnings and notes

There are two types of safety instructions throughout this manual: warnings and notes. Warnings caution you about conditions which can result in serious injury or death and/or damage to the equipment. They also tell you how to avoid the danger. Notes draw attention to a particular condition or fact, or give information on a subject. The warning symbols are used as follows:



Dangerous voltage warning warns of high voltage which can cause physical injury and/or damage to the equipment.



General warning warns about conditions, other than those caused by electricity, which can result in physical injury and/or damage to the equipment.



Electrostatic discharge warning warns of electrostatic discharge which can damage the equipment.

Installation and maintenance work

These warnings are intended for all who work on the drive, motor cable or motor. Ignoring the instructions can cause physical injury or death.



Only qualified electricians are allowed to install and maintain the drive.

- Never work on the drive, motor cable or motor when main power is applied.
 - Always ensure by measuring with a multimeter (impedance at least 1 Mohm) that:
 1. Voltage between drive input phases U1, V1 and W1 and the frame is close to 0 V.
 2. Voltage between terminals C1 and D1 and the frame is close to 0 V.
 - Do not work on the control cables when power is applied to the drive or to the external control circuits. Externally supplied control circuits may cause dangerous voltages inside the drive even when the main power on the drive is switched off.
-

- Do not make any insulation or voltage withstand tests on the drive or drive modules.
 - When reconnecting the motor cable, always check that the C1 and D1 terminal is correct.
-

Note:

- The motor cable terminals on the drive are at a dangerously high voltage when the input power is on, regardless of whether the motor is running or not.
 - Depending on the external wiring, dangerous voltages (115 V, 220 V or 230 V) may be present on the terminals of relay outputs SDCS-IOB-2, RDIO.
 - DCS800 with enclosure extension: Before working on the drive, isolate the whole drive from the supply.
-

Grounding

WARNING! Printed circuit boards contain components sensitive to electrostatic discharge. Wear a grounding wrist band when handling the boards. Do not touch the boards unnecessarily.

These instructions are intended for all who are responsible for the grounding of the drive. Incorrect grounding can cause physical injury, death or equipment malfunction and increase electromagnetic interference.



- Ground the drive, motor and adjoining equipment to ensure personnel safety in all circumstances, and to reduce electromagnetic emission and pick-up.
 - Make sure that grounding conductors are adequately sized as required by safety regulations.
 - In a multiple-drive installation, connect each drive separately to protective earth (PE).
 - Minimize EMC emission and make a 360° high frequency grounding of screened cable entries at the cabinet lead-through.
 - Do not install a drive with EMC filter on an ungrounded power system or a high resistance-grounded (over 30 ohms) power system.
-

Note:

- Power cable shields are suitable for equipment grounding conductors only when adequately sized to meet safety regulations.
 - As the normal leakage current of the drive is higher than 3.5 mA AC or 10 mA DC (stated by EN 50178, 5.2.11.1), a fixed protective earth connection is required.
-

Fiber optic cables



WARNING! Handle the fiber optic cables with care. When unplugging optic cables, always grab the connector, not the cable itself. Do not touch the ends of the fibers with bare hands as the fiber is extremely sensitive to dirt. The minimum allowed bend radius is 35 mm (1.4 in.).

Mechanical installation



These notes are intended for all who install the drive. Handle the unit carefully to avoid damage and injury.

- DCS800-EP Frames A and B: The drives are heavy and may require more than one person to lift. Use appropriate lifting techniques. Do not lift the unit by the front cover. Place the unit only on its back.
 - DCS800-EP Frames C and D: The drive is heavy. Lift the drive by the lifting lugs only.
 - Make sure that dust from drilling does not enter the drive when installing. Electrically conductive dust inside the unit may cause damage or lead to malfunction.
 - Ensure sufficient cooling.
 - Do not fasten the drive by riveting or welding.
-

Operation

These warnings are intended for all who plan the operation of the drive or operate the drive. Ignoring the instructions can cause physical injury or death or damage the equipment.



- Before adjusting the drive and putting it into service, make sure that the motor and all driven equipment are suitable for operation throughout the speed range provided by the drive. The drive can be adjusted to operate the motor at speeds above and below the base speed.
- Do not activate automatic fault reset functions of the Standard Application Program if dangerous situations can occur. When activated, these functions will reset the drive and resume operation after a fault.
- Do not control the motor with the disconnecting device (disconnecting switch); instead, use the control panel keys and , or commands via the I/O board of the drive.
- **Mains connection**
You can use a switch disconnect in the power supply of the thyristor power converter to disconnect the electrical components of the unit from the power supply for installation and maintenance work. The type of disconnect used must be a switch disconnect as per EN 60947-3, Class B, so as to comply with EU regulations, or a circuit-breaker type which switches off the load circuit by means of an auxiliary contact causing the breaker's main contacts to open. The mains disconnect must be locked in its "OPEN" position during any installation and maintenance work.
- EMERGENCY STOP buttons must be installed at each control desk and at all other control panels requiring an emergency stop function. Pressing the STOP button on the control panel of the thyristor power converter will neither cause an emergency motor stop, nor will the drive be disconnected from any dangerous potential.

To avoid unintentional operating states, or to shut the unit down in case of any imminent danger, according to the standards in the safety instructions it is not sufficient to merely shut down the drive via signals "RUN", "Drive OFF" or "Emergency Stop" with "Control Panel" or "PC Tool".

- **Intended use**
The operating instructions cannot take into consideration every possible system configuration, operation or maintenance. Thus, they mainly give such advice only, which is required by qualified personnel for normal operation of the machines and devices in industrial installations.

If in special cases the electrical machines and devices are intended for use in non-industrial installations - which may require stricter safety regulations (e.g. protection against contact by children or similar). These additional safety measures for the installation must be provided by the customer during assembly.



Note:

When the control location is not set to Local (L not shown in the PC tool status row), the **Stop** key on the control panel **WILL NOT** stop the drive.

Table of contents

Safety instructions	2
Use of warnings and notes	2
Installation and maintenance work	2
Mechanical installation	4
Operation	5
Table of contents	6
The DCS800-EP	8
Type codes and Plus Codes	9
Options	10
Other DCS800 documentation	10
Mechanical installation	11
Unpacking the unit	11
Delivery check	11
Requirements for installation	12
Cabinet cooling and air flow	13
Panel heat dissipation	13
Planning the electrical installation	14
Options for the drive	14
Typical cable sizing and tightening torque	16
Electrical installation	17
Checking the insulation of the assembly	17
IT (ungrounded) systems	18
Check supply voltages	18
Connecting the power cables	18
Electrical diagrams	20
Connection diagrams	21
Control circuit connections	23
Alternate line voltage (converting to 230 Vac line)	24
Installation Checklist	25
Check	25
Dimensions	26
Dimensional data	26
Dimensional drawings	27

Replacement Parts	29
Fuses	29
Blower motor starter	30
Other replacement parts	30
Technical Data	31
Electrical and environmental data	31
Accessories	32
Line reactors	32
Diagrams	33
Power	33
Control	36
Index	38

The DCS800-EP

What this chapter contains

This chapter briefly describes the operating principle and construction of the DCS800-EP Panel Drive.

The DCS800-EP

The DCS800-EP sizes D1 through D4 are intended as a pre-packaged or “panelized” solution for controlling DC motors.



Size A
17...104 A

Available at a later date



Size B
125...205 A

Available at a later date

Size C
245...405 A

Size D
480...950 A

Type codes and Plus Codes

The type code contains information on the specifications and configuration of the drive. The first digits from left express the basic configuration (e.g. DCS800-EP2-0050). The optional selections are given thereafter, on the name plate by plus code. The main selections are described below. Not all selections are available for all types.

Type code: D C S 8 0 0 - EP X - Y Y Y Y - Z Z - plus code

The “P” in the type code designates the panel drive configuration. Further explanation of the type code can be found in the DCS800 Hardware Manual in the chapter “The DCS800.”

Non-Regenerative (2Q)	Regenerative (4Q)	Module Frame	Panel Frame	HP at 230V	HP at 460V	*Amps	
						AC in	DC out
DCS800-EP1-0020-05	DCS800-EP2-0025-05	D1	A	5	10	14	17
DCS800-EP1-0045-05	DCS800-EP2-0050-05	D1	A	10	20	29	35
DCS800-EP1-0065-05	DCS800-EP2-0075-05	D1	A	15	30	43	53
DCS800-EP1-0090-05	DCS800-EP2-0100-05	D1	A	20	40	55	68
DCS800-EP1-0125-05	DCS800-EP2-0140-05	D1	A	30	60	85	104
DCS800-EP1-0180-05	–	D2	B	35	75	102	125
–	DCS800-EP2-0200-05	D2	B	50	100	134	164
DCS800-EP1-0230-05	DCS800-EP2-0260-05	D2	B	60	125	167	205
DCS800-EP1-0315-05	DCS800-EP2-0350-05	D3	B	75	150	200	245
DCS800-EP1-0405-05	DCS800-EP2-0450-05	D3	C	100	200	265	325
DCS800-EP1-0470-05	DCS800-EP2-0520-05	D3	C	125	250	330	405
DCS800-EP1-0610-05	DCS800-EP2-0680-05	D4	C	150	300	392	480
DCS800-EP1-0740-05	DCS800-EP2-0820-05	D4	D	-	400	522	640
DCS800-EP1-0900-05	DCS800-EP2-1000-05	D4	D	-	500	649	795
–	DCS800-EP2-1010-05	D4	D	-	600	775	950

Power and current ratings above are based on Heavy Duty rating, 150% overload for 60 sec., except for 600 HP drive which is rated at 110% overload for 60 sec.

*DC Amps based on standard NEMA motor tables. AC Amps = DC Amps * 0.816



IMPORTANT:

Do not exceed the continuous and overload current ratings shown above. The drive panel is not designed to withstand higher currents. Failure to adhere to this warning can result in personal injury and/or damage to equipment.

Options

	Plus Code	Option Kit
1. Circuit Breaker (All Sizes)	+F278	NA
2. AC Line Reactor DCS800-EP1-0020-05 through DCS800-EP2-0350-05	+E213	NA
3. Without AC Line Contactor DCS800-EP1-0020-05 through DCS800-EP2-0680-05	+0F250	NA
4. 230 Vac supply voltage	+S235	DCS800-EP 230VAC Supply
5. Fan/blower motor starters		
1.0 – 1.6 Amps	+M600	NA
1.6 – 2.4 Amps	+M601	NA
2.4 – 4.0 Amps	+M602	NA
4.0 – 6.0 Amps	+M603	NA
6.0 – 9.0 Amps	+M604	NA

Other DCS800 documentation

This manual describes the unique features of the DCS800-EP Panel Drive. For general information about the DCS800 module, please refer to the following:

DCS800 Quick Guide	3ADW000191
DCS800 Firmware Manual	3ADW000193
DCS800 Hardware Manual (modules)	3ADW000194
DCS800 Technical Catalog	DCS800-PHTC01U-EN

*See the Firmware Manual or Hardware Manual for references to other DCS800 publications.

Mechanical installation

Unpacking the unit

- Remove the corrugated paperboard box by removing the shipping straps and lifting the box up and off of the shipping pallet.
- Remove the screws holding the drive to the wood pallet.
- For frame A, the drive can be lifted. All drives have lifting holes to allow for mechanical lift.



Delivery check

- Check that there are no signs of damage.
- Before attempting installation and operation, check the information on the label of the drive to verify that the unit is of the correct size and type. A typical label is shown.

DCS800 PANEL DRIVE		Model No.	DCS800-EP1-0020-05+F278+E213+0F250+M602			UL File #E165086		
(A) 781	Amps Total	SCCR	65	KA RMS sym. @460V	Power (Pn)	(G) 600HP	450 kW	
(B) 775	A (largest motor)	Input (I1n)	(C) 775	A	Volts (U1)	230/460-3 (E)	Hz	50/60
See Hardware Manual		Output (I2n)	(D) 950	Adc	Volts (U2)	240/500dc (F)	Field (If)	6 Adc

- A Input current for entire panel
 B Input current for the drive module only
 C Drive module rated input current
 D Drive module rated output current
 E Drive module rated input voltage
 F Drive module rated output voltage
 G Drive module rated power

Requirements for installation

The drive must be installed in an upright position within a cabinet or other enclosure.

The cabinet size, heat dissipation capability and clearances must conform to the requirements below.

Refer to *Dimensional drawings* for frame details.

See *Cabinet cooling and air flow* for the allowed ambient conditions of the drive.

Minimum clearances

When installing the panel in a cabinet, minimum clearances from the panel to the cabinet walls, top and bottom must be maintained. This space is required for proper cabling, cooling air flow, service and maintenance. If one drive is mounted directly above another, see DCS800 Hardware Manual “Mechanical Installation” for additional information.

See chapter *Dimensional drawings*.

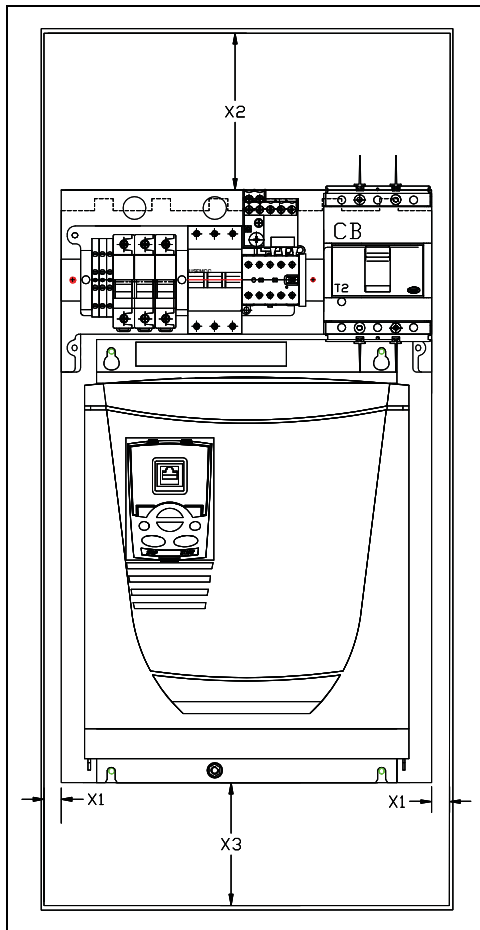

Frame	X1 (side)	X2 (top)	X3 (bottom)
A	0.5 in. (13 mm)	5.0 in. (13 mm)	4.0 in. (102 mm)
B	0.5 in. (13 mm)	10.0 in. (25 mm)	5.0 in. (127 mm)
C	TBD		
D			

Cabinet cooling and air flow

Cabinets must be sized to accommodate minimum clearances as described in the previous section and in the DCS800 Hardware Manual.

The maximum interior cabinet ambient temperature must not exceed 40°C.

See table below for heat dissipation requirements. Cooling air enters the bottom of the drive module and exits at the top (see diagram at right).

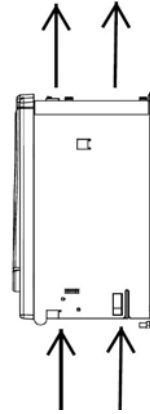

Panel heat dissipation

HP	Non-Regenerative (2Q)			Regenerative (4Q)		
	Type Code	Total panel watts loss		Type Code	Total panel watts loss	
		without inductor	with inductor		without inductor	with inductor
10	DCS800-EP1-0020-05	162	182	DCS800-EP2-0025-05	170	190
20	DCS800-EP1-0045-05	228	283	DCS800-EP2-0050-05	246	301
30	DCS800-EP1-0065-05	291	350	DCS800-EP2-0075-05	319	378
40	DCS800-EP1-0090-05	356	426	DCS800-EP2-0100-05	387	457
60	DCS800-EP1-0125-05	483	578	DCS800-EP2-0140-05	530	625
75	DCS800-EP1-0180-05	656	751			
100				DCS800-EP2-0200-05	776	903
125	DCS800-EP1-0230-05	882	1017	DCS800-EP2-0260-05	960	1095
150	DCS800-EP1-0315-05	1074	1209	DCS800-EP2-0350-05	1168	1303
200	DCS800-EP1-0405-05	1326	–	DCS800-EP2-0450-05	1426	–
250	DCS800-EP1-0470-05	1551	–	DCS800-EP2-0520-05	1695	–
300	DCS800-EP1-0610-05	1996	–	DCS800-EP2-0680-05	2167	–
400	DCS800-EP1-0740-05	2334	–	DCS800-EP2-0820-05	2552	–
500	DCS800-EP1-0900-05	2982	–	DCS800-EP2-1000-05	3252	–
600				DCS800-EP2-1010-05	3305	–

Planning the electrical installation

What this chapter contains

This chapter contains the instructions for selecting the cables, cable routing and line reactors for the drive panel. Always follow local regulations.

Note: If the recommendations given by ABB are not followed, the drive may experience problems that are not necessarily covered by the warranty.

Reference: *Technical Guide* – publ. no.: 3ADW000163

Options for the drive

Line reactors

When thyristor power converters operate, the line voltage is short-circuited during commutation from one thyristor to the next. This operation causes voltage dips in the mains PCC (point of common coupling). Some ACS800-EP Panel Drives are shipped with an internal 1.5% line reactor and some are not (as indicated by the drive's Plus Code). For the connection of a power converter system to the mains, one of the following configurations should be applied:

Configuration A

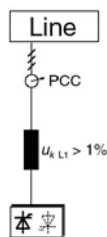

When using the power converter, a minimum of impedance is required to ensure proper performance of the snubber circuit. A line reactor can be used to meet this minimum impedance requirement. The value must therefore not drop below 1% u_k (relative impedance voltage). It should not exceed 10% u_k , due to considerable voltage drops at converter output.

Configuration B

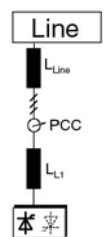

If special requirements have to be met at the PCC (standards like EN 61800-3, DC and AC drives at the same line, etc), different criteria must be applied for selecting a line reactor. These requirements are often defined as a voltage dip in percent of the nominal supply voltage. The combined impedance of $Z_{L_{Line}}$ and Z_{L_1} constitute the total series impedance of the installation. The ratio between the line impedance and the line reactor impedance determines the voltage dip at the connecting point. In such cases line chokes with an impedance around 4% are often used.

Example calculation with $U_{k L_{Line}}=1\%$; $U_{k L_1}=4\%$; **Voltage Dip = $Z_{L_{Line}} / (Z_{L_{Line}}+Z_{L_1})=20\%$** . Detailed calculation see Technical Guide.

Line reactors (cont)

Configuration C

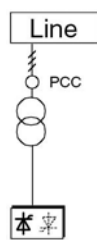

If an isolation transformer is used, it is possible to comply with certain connecting conditions per Configuration B without using an additional line reactor. The condition described in Configuration A will then likewise be satisfied, since the u_k is $>1\%$.

Configuration C1

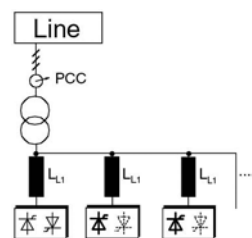

If 2 or more converters are supplied by one transformer, the final configuration depends on the number of drives in use and their power capability.

Either configuration A or B (which are based on commutation chokes) has to be used, if the drive system consists of any of the converters (D1, D2, D3, D4.)

With reference to the power converter:

The line reactors are listed in the table on page 30. They:

- have been sized to the units nominal current
- are based on a duty cycle

For further information in this publication:

See chapter *Accessories - Line reactors*.

Typical cable sizing and tightening torque

Based on U.S. NEC Table 310.16. No more than three current carrying conductors per raceway.
Maximum Ambient Temperature - 40°C, Conductor Temperature Rating - 75°C except where noted.

Drive Panel	HP	AC input L1, L2, L3		DC output C2, D2		Ground PE	Tightening Torque (ft-lb)	
		IAC (amps)	Typical Cable	IDC (amps)	Typical Cable	Minimum Cable ①	L1-L2-L3 with breaker	C2, D2, PE & L1-L2-L3 with- out breaker
DCS800-EP1-0020-05	10	14	12 AWG	17	10 AWG	12 AWG	35 in-lb	10
DCS800-EP2-0025-05	10	14	12 AWG	17	8 AWG	12 AWG	35-40 in-lb	10
DCS800-EP1-0045-05	20	29	8 AWG	35	8 AWG	10 AWG	45 in-lb	10
DCS800-EP2-0050-05	20	29	8 AWG	35	8 AWG	10 AWG	45 in-lb	10
DCS800-EP1-0065-05	30	43	6 AWG	53	6 AWG	10 AWG	45-50 in-lb	10
DCS800-EP2-0075-05	30	43	6 AWG	53	6 AWG	10 AWG	50 in-lb	10
DCS800-EP1-0090-05	40	55	4 AWG	68	4 AWG	8 AWG	50 in-lb	10
DCS800-EP2-0100-05	40	55	4 AWG	68	4 AWG	8 AWG	50 in-lb	10
DCS800-EP1-0125-05	60	85	2 AWG	104	1 AWG	6 AWG	50 in-lb	10
DCS800-EP2-0140-05	60	85	2 AWG	104	1 AWG	6 AWG	50 in-lb	10
DCS800-EP1-0180-05	75	102	1 AWG	125	2/0 AWG	6 AWG	23	23, 31 (PE)
DCS800-EP2-0200-05	100	134	3/0 MCM	164	4/0 AWG	6 AWG	23	23, 31 (PE)
DCS800-EP1-0230-05	125	167	4/0 MCM	205	300 MCM	4 AWG	23	23, 31 (PE)
DCS800-EP2-0260-05	125	167	4/0 MCM	205	300 MCM	4 AWG	23	23, 31 (PE)
DCS800-EP1-0315-05	150	200	250 MCM	245	350 MCM	4 AWG	23	23, 31 (PE)
DCS800-EP2-0350-05	150	200	250 AWG	245	350 MCM	4 AWG	23	23, 31 (PE)
DCS800-EP1-0405-05	200	265	350 AWG	325	2 x 4/0 AWG	2 AWG	TBD	TBD
DCS800-EP2-0450-05	200	265	350 AWG	325	2 x 4/0 AWG	2 AWG		
DCS800-EP1-0470-05	250	330	2 x 4/0 AWG	405	2 x 250 AWG	2 AWG		
DCS800-EP2-0520-05	250	330	2 x 4/0 AWG	405	2 x 250 AWG	2 AWG		
DCS800-EP1-0610-05	300	392	2 x 250 AWG	480	2 x 350 AWG	2 AWG		
DCS800-EP2-0680-05	300	392	2 x 250 AWG	480	2 x 350 AWG	2 AWG		
DCS800-EP1-0740-05	400	522	TBD	640	TBD	TBD		
DCS800-EP2-0820-05	400	522		640				
DCS800-EP1-0900-05	500	649		795				
DCS800-EP2-1000-05	500	649		795				
DCS800-EP2-1010-05	600	775		950				
				950				

① The minimum ground cable recommendation assumes that the overcurrent protection for each drive is selected to provide protection at 125% of the rated drive input current. If the overcurrent protection (e.g. circuit breaker) is sized larger than this, then larger ground cables will need to be determined manually.

Electrical installation

What this chapter contains

This chapter describes the electrical installation procedure of the drive.



WARNING! The work described in this chapter may only be carried out by a qualified electrician. Follow the *Safety instructions* on the first pages of this manual. Ignoring the safety instructions can cause injury or death.

Make sure that the drive is disconnected from the mains (input power) during installation. If the drive was already connected to the mains, wait for 5 min. after disconnecting mains power.

Reference: *Technical Guide* - publ. no.: 3ADW000163

Checking the insulation of the assembly

Each drive is factory tested for insulation between the main circuit and the chassis (2500 V rms 50 Hz for 1 second). DO NOT make any voltage tolerance or insulation resistance tests (e.g. hi-pot or megger) on any part of the drive or drive damage will occur. Check the insulation of the assembly as follows.



WARNING! Check the insulation before connecting the drive to the mains. Make sure that the drive is disconnected from the mains (input power).

1. Check that the motor cable is disconnected from the drive output terminals C1, D1, F+ and F-.
 2. Measure the insulation resistances of the motor cable and the motor between each circuit (C1, D1) or (F+, F-) and the Protective Earth by using a measuring voltage of 1 kV DC. The insulation resistance must be higher than 1 Mohm.
-

IT (ungrounded) systems

Don't use EMC filters.

The screen winding of dedicated transformers must be grounded.

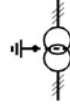

For installation without low voltage switch (e.g. contactor, air-circuit-breaker) use overvoltage protection.

The voltage shift of isolated supply must be limited of a range of an earth fault.

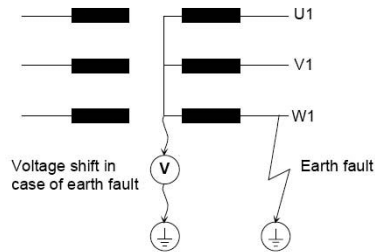

Check supply voltages

- Aux X99
- Fan Terminals
- AC voltage for armature circuit U1, V1, W1

Connecting the power cables

Grounding and screening of power cables see manual *Technical Guide*, see *Reference*.

Cross sectional areas and tightening torques of power cable see chapter *Planning the electrical installation*.

Power/control connections

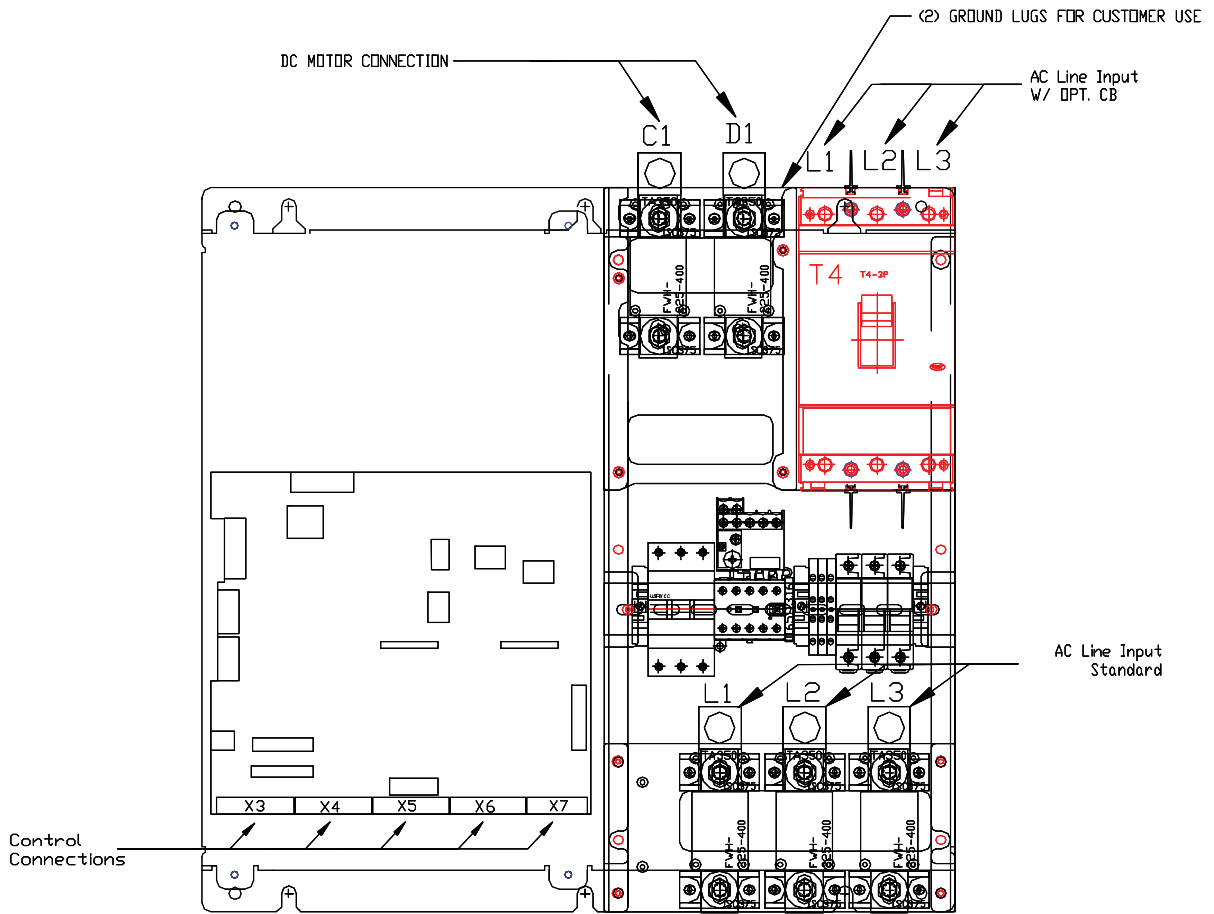

Typical location for input and output terminals.

Electrical diagrams

The table below lists the correct electrical diagrams for each panel drive.

Non-Regenerative (2Q)	Regenerative (4Q)	Frame	HP	Connection Diagram Pgs 21 - 22	Power Diagram Pgs 34 - 35	Control Diagram Pgs 36 - 37
DCS800-EP1-0020-05	DCS800-EP2-0025-05	A	10	CON-1	P1	C1
DCS800-EP1-0045-05	DCS800-EP2-0050-05	A	20	CON-1	P1	C1
DCS800-EP1-0065-05	DCS800-EP2-0075-05	A	30	CON-1	P1	C1
DCS800-EP1-0090-05	DCS800-EP2-0100-05	A	40	CON-1	P1	C1
DCS800-EP1-0125-05	DCS800-EP2-0140-05	A	60	CON-1	P1	C1
DCS800-EP1-0180-05	–	B	75	CON-1	P1	C1
–	DCS800-EP2-0200-05	B	100	CON-1	P1	C1
DCS800-EP1-0230-05	DCS800-EP2-0260-05	B	125	CON-1	P1	C1
DCS800-EP1-0315-05	DCS800-EP2-0350-05	B	150	CON-1	P1	C1
DCS800-EP1-0405-05	DCS800-EP2-0450-05	C	200	CON-1	P2	C1
DCS800-EP1-0470-05	DCS800-EP2-0520-05	C	250	CON-1	P2	C1
DCS800-EP1-0610-05	DCS800-EP2-0680-05	C	300	CON-1	P2	C1
DCS800-EP1-0740-05	DCS800-EP2-0820-05	D	400	CON-2	P3	C2
DCS800-EP1-0900-05	DCS800-EP2-1000-05	D	500	CON-2	P3	C2
–	DCS800-EP2-1010-05	D	600	CON-2	P3	C2

Connection diagrams

CON-1 Connection Diagram Panel A-C

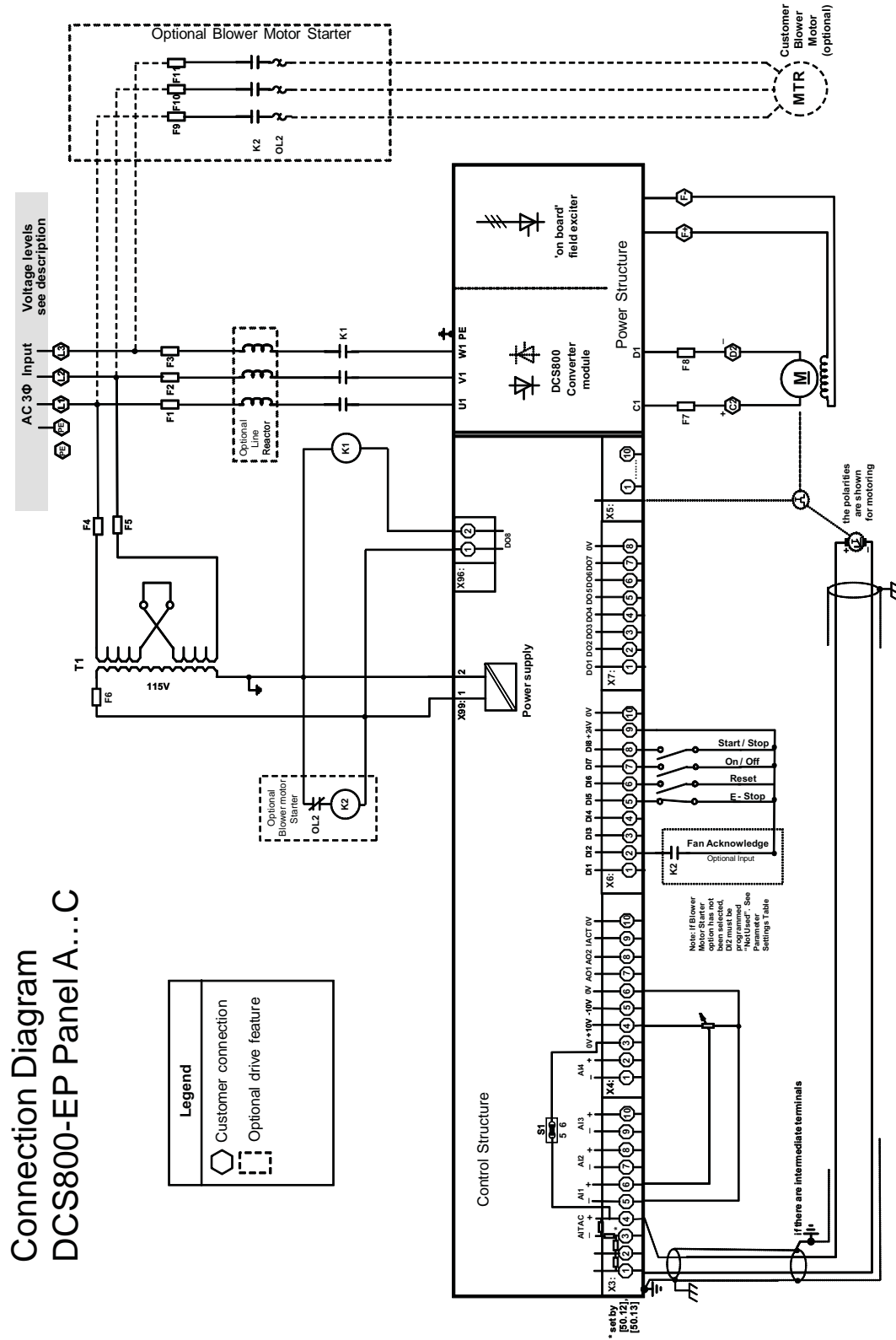

CON-2 Connection Diagram Panel D

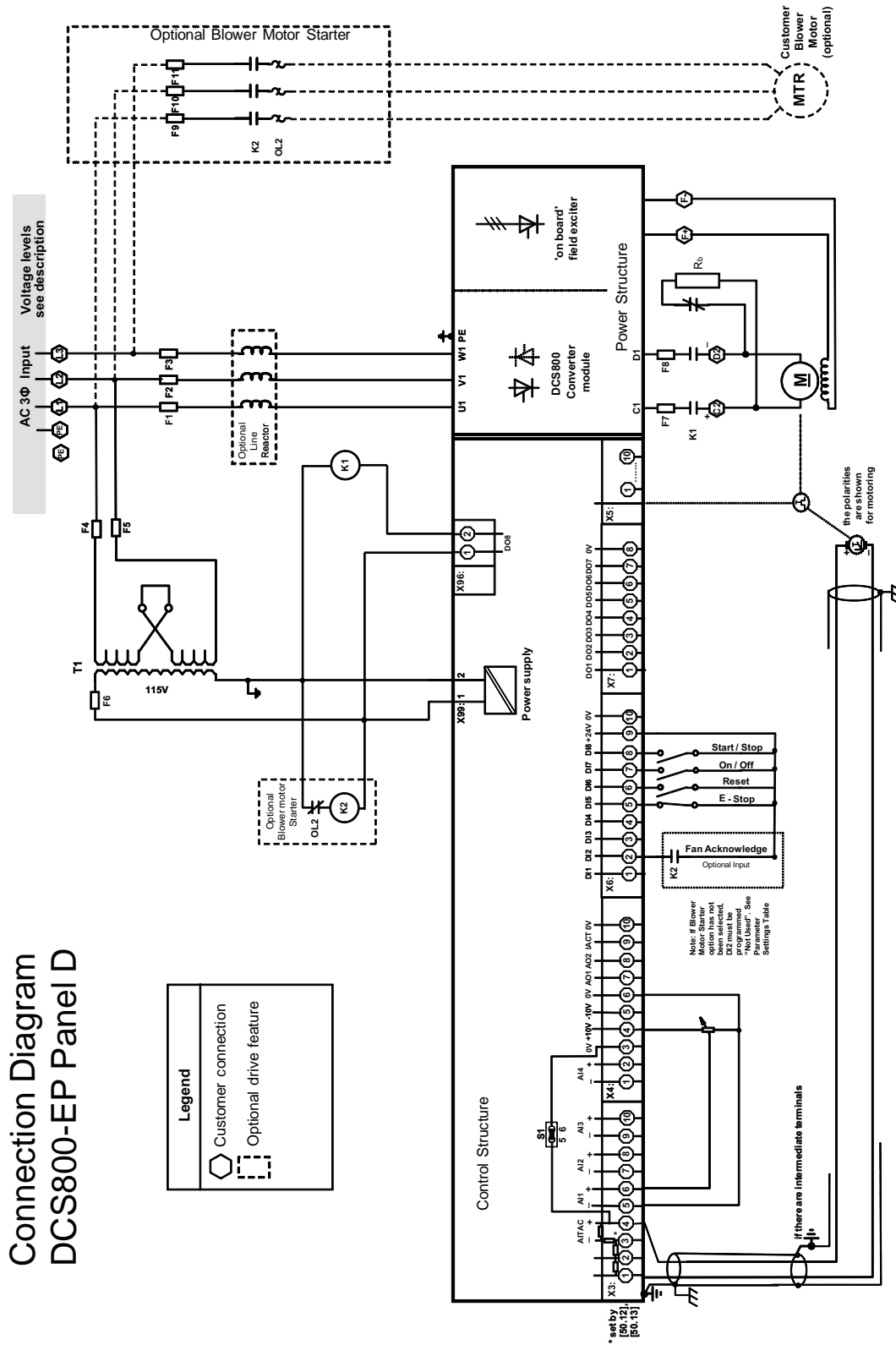

Control circuit connections

Parameter settings for I/O

Digital Inputs

Input	Function	Parameter	Setting	Notes
1	Unused	10.20	NOT USED	
2	Fan Acknowledge	10.06	DI2	Change to "not used" if optional blower motor starter is not selected.
3	Unused	10.21	NOT USED	
4	Unused	10.08	NOT USED	
5	E-Stop	10.09	DI5	
6	Reset	10.03	DI6	
7	On / Off	10.15	DI7	
8	Start / Stop	10.16	DI8	

NOTE: Setting "On / Off" will command the drive to close the contactor and enable the SCRs to fire at a neutral setting. When "Start / Stop" is set, the motor will accelerate to the reference speed.

Analog Inputs

Input	Function	Parameter	Setting	Notes
AI1	Speed Reference	11.03 13.01 13.02 13.03	Dependent on type of reference input	See 5.03 for actual AI1 value

Alternate line voltage (converting to 230 Vac line)

Drive panels as received from the factory, except if "+S235" is in the type code (see page 10), are wired for an input voltage of 460 V, 60 Hz. If the ac input line voltage is to be 230 Vac, modifications must be made.



230/460 Vac rated drives can be configured for either 230 or 460 Vac input power. Before applying power, it is required to verify the control transformer configuration matches the incoming power. This is done by checking the jumpers on the "H" side of the transformer or by following the test procedure shown below. Failure to follow this precaution could result in severe damage.

DCS800-EPx-020-05 thru DCS800-EPx-1000-05

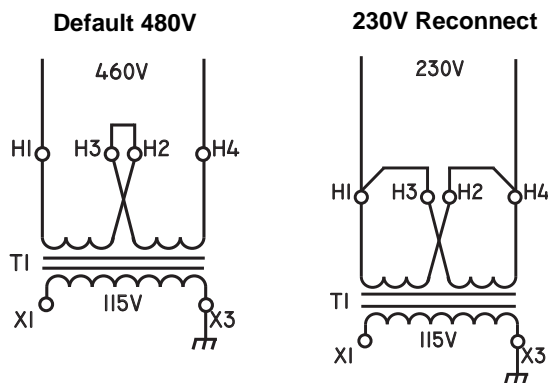

Input Power	F4 and F5 Fuses
DCS800-EPx-350-05 and below	
230 Vac input	Use (2) FNQR 2
460 Vac input	Use (2) FNQR 1-1/8
DCS800-EPx-405-05 and above	
230 Vac input	Use (2) FNQR XX
460 Vac input	Use (2) FNQR XX

230 Vac Modification Procedure

1. Disconnect and lock out all incoming power to the drive.
2. Locate the control transformer. For panel frame A, drive module must be removed to gain access. (Carefully unplug green connectors X3 - X7 first.) For panel frame B, transformer is located below line fuses.
3. Remove the jumper between H2 and H3.
4. Reconnect new jumpers between H1 and H3 and between H2 and H4. Remount and reconnect the drive (frame A).
5. Remove and replace the primary fuses F4 and F5 with fuses shown in the table above.

Live Test Procedure

1. Open the F6 fuse holder to disconnect control power to the drive and blower motor starter (if present).
2. Connect 3-phase power and close disconnect 1MCB.
3. Measure voltage between fuse F6 and Terminal 2. If not 110 to 120 Vac, disconnect 3-phase power and open disconnect 1MCB. Reconfigure control transformer jumpers. Repeat live test.
4. Close the F6 fuse holder. Control power to the drive should then be connected. Control Panel will light up.
5. The drive module itself must be reprogrammed for 230 Vac input by adjusting parameter 99.10 (Nominal AC mains voltage) to a value of "230."

Installation Checklist

Check the mechanical and electrical installation of the drive before start-up. Go through the checklist below together with another person. Read the *Safety instructions* on the first pages of this manual before you work on the unit.

Check

Mechanical Installation

- The cabinet internal ambient temperature and the external ambient air temperature are within limits (See Mechanical installation and Technical data).
- The cabinet is vertically mounted on a non-flammable surface.
- The cooling air can flow freely.
- The motor and the driven equipment are ready for start. (See Planning the electrical installation)
- All shield and grounding connections are properly tightened.
- All cable connections are seated properly and tightened according to specified torque. (See Typical cable sizing and tightening torque)

Electrical Installation

(See Planning the electrical installation, Electrical installation)

- The drive is properly grounded.
 - The AC input voltage matches the drive nominal input voltage.
 - The AC input cables are properly seated and tightened to specified torque. (See Typical cable sizing and tightening torque)
 - The motor cables (C1, D1 and F+, F-) are properly seated and tightened to specified torque. (See Typical cable sizing and tightening torque)
 - Proper function of the E-Stop circuitry.
 - Fan power wiring is connected.
 - Control connections are properly made and logic is sound.
 - There are no tools, foreign objects, dust or debris from drilling inside the drive.
 - Covers are in place on the drive, motor and any connection boxes.
-

Dimensions

Dimensional data

DSC800-EP Panel Drive				
HP at 460 Vac	Panel Size	Height in. (mm)	Width in. (mm)	Depth in. (mm)
10	A	18.79 (477)	12.15 (309)	14.40 (366)
20				
30				
40				
60				
75	B	19.32 (491)	20.00 (508)	13.92 ① (354)
100				
125				
150				
200	C	TBD		
250				
300				
400	D	TBD		
500				
600				

NOTE ①: Optional line reactor increases depth by 19.3" (490 mm).

Dimensional drawings

Panel A

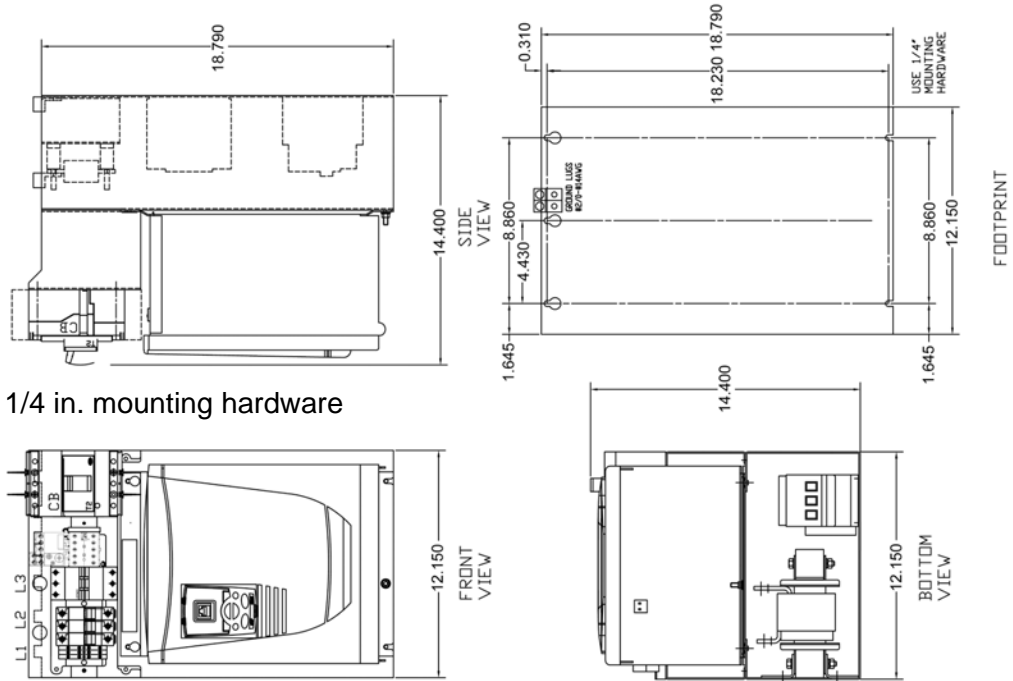

Use M6 or 1/4 in. mounting hardware

Panel B

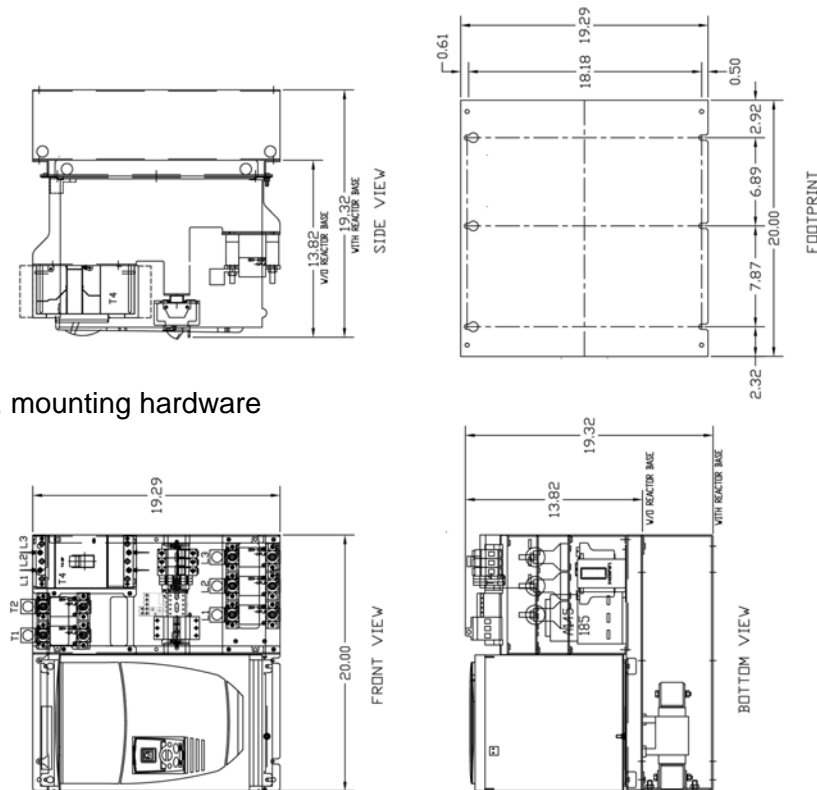

Use M8 or 5/16 in. mounting hardware

This page intentionally left blank

Replacement Parts

Fuses

Panel Drive		Frame	Fuse				AC in (Blower motor starter) F9, F10, F11
Non-Regenerative	AC in (module) F1, F2, F3		Control Xfrm primary F4, F5 (2 Req'd)	Control Xfrm secondary F6	DC Out (motor) F7, F8, (2 Req'd)		
Regenerative	Manufacturer		Manufacturer	Manufacturer	Manufacturer		
DCS800-EP1-0020-05 DCS800-EP2-0025-05	A	FWH-50B	For 480 Vac input voltage: FNQ-R-1-1/8	FNM-2-8/10	FWH-50B	See Table Below	
DCS800-EP1-0045-05 DCS800-EP2-0050-05	A	FWH-80B			FWH-80B		
DCS800-EP1-0065-05 DCS800-EP2-0075-05	A	FWH-80B			FWH-80B		
DCS800-EP1-0090-05 DCS800-EP2-0100-05	A	FWH-125B			FWH-125B		
DCS800-EP1-0125-05 DCS800-EP2-0140-05	A	FWH-125B			FWH-125B		
DCS800-EP1-0180-05 -	B	FWH-200B			FWH-200B		
- DCS800-EP2-0200-05	B	FWH-200B			FWH-200B		
DCS800-EP1-0230-05 DCS800-EP2-0260-05	B	FWH-250A			FWH-250A		
DCS800-EP1-0315-05 DCS800-EP2-0350-05	B	FWH-300A			FWH-300A		
DCS800-EP1-0405-05 DCS800-EP2-0450-05	C	FWH-500A			TBD		TBD
DCS800-EP1-0470-05 DCS800-EP2-0520-05	C	FWH-700A	FWH-700A				
DCS800-EP1-0610-05 DCS800-EP2-0680-05	C	FWH-700A	FWH-700A				
DCS800-EP1-0740-05 DCS800-EP2-0820-05	D	FWH-1000A	FWH-1000A				
DCS800-EP1-0900-05 DCS800-EP2-1000-05	D	FWH-1000A	FWH-1000A				
- DCS800-EP2-1010-05	D	FWH-1200A	FWH-1200A				

Blower motor starter

Plus Code	Blower HP 460Vac	Blower HP 230Vac	Blower Amps 460V/230V	Fuses F9, F10, F11	Contactor	Overload
				Busmann	ABB	ABB
+M600	1/2	-	1.1	LP-CC-3 1/2	Mini Contactor 120VAC coil B7-30-10-84	T7DU1.6
+M600	3/4	-	1.6	LP-CC-5		T7DU1.6
+M601	1	1/2	2.1/2.2	LP-CC-5		T7DU2.4
+M602	1.5	3/4	3.0/3.2	LP-CC-8		T7DU4.0
+M602	2	-	3.4	LP-CC-10		T7DU4.0
+M602	-	1	4.2	LP-CC-15	Mini Contactor 120VAC coil B7-30-10-84	T7DU4.0
+M603	3	-	4.8	LP-CC-15		T7DU6.0
+M603	-	1 1/2	6.0	LP-CC-20		T7DU6.0
+M604	-	2	6.8	LP-CC-20		T7DU9.0
+M604	5	-	7.6	LP-CC-25		T7DU9.0

Note: Fuse in BOLD is as supplied by ABB with plus code

Other replacement parts

Panel Drive	Frame	AC Input Contactor K1 (1)	DC Output Contactor (1)	Control Transformer T1 (1)	Circuit Breaker 1MCB (1)	Line Reactor (1)
Non-Regenerative Regenerative		ABB	ABB	Micron	ABB	TCI
Manufacturer		ABB	ABB	Micron	ABB	TCI
DCS800-EP1-0020-05 DCS800-EP2-0025-05	A	A16-30-11-84	NA	1B250BTZ13RBF	T2H025E5W	KLR16BTB
DCS800-EP1-0045-05 DCS800-EP2-0050-05	A	A26-30-11-84	NA	1B250BTZ13RBF	T2H060E5W	KLR35BTB
DCS800-EP1-0065-05 DCS800-EP2-0075-05	A	A40-30-11-84	NA	1B250BTZ13RBF	T2H060E5W	KLR45BTB
DCS800-EP1-0090-05 DCS800-EP2-0100-05	A	A50-30-11-84	NA	1B250BTZ13RBF	T2H100E5W	KLR55BCB
DCS800-EP1-0125-05 DCS800-EP2-0140-05	A	A75-30-11-84	NA	1B250BTZ13RBF	T2HQ100BW	KLR110BCB
DCS800-EP1-0180-05 -	B	A95-30-11-84	NA	1B250BTZ13RBF	T4H150E5W	KLR110BCB
- DCS800-EP2-0200-05	B	A145-30-11-84	NA	1B250BTZ13RBF	T4H250E5W	KLR160BCB
DCS800-EP1-0230-05 DCS800-EP2-0260-05	B	A145-30-11-84	NA	1B250BTZ13RBF	T4H250E5W	KLR200BCB
DCS800-EP1-0315-05 DCS800-EP2-0350-05	B	A145-30-11-84	NA	1B250BTZ13RBF	T4H250E5W	KLR200BCB
DCS800-EP1-0405-05 DCS800-EP2-0450-05	C	A260-30-11-84	NA	TBD	T5H400E5W	KLR300BCB
DCS800-EP1-0470-05 DCS800-EP2-0520-05	C	A300-30-11-84	NA	TBD	T5H600E5WW	KLR360BCB
DCS800-EP1-0610-05 DCS800-EP2-0680-05	C	AF400-30-11-70	NA	TBD	T5H600E5W	KLR420BCB
DCS800-EP1-0740-05 DCS800-EP2-0820-05	D	NA	EHDB650C-1L	TBD	T6H800E5W	KLR600BCB
DCS800-EP1-0900-05 DCS800-EP2-1000-05	D	NA	EHDB800C-1L	TBD	T7H1200E5W	KLR750BCB
- DCS800-EP2-1010-05	D	NA	EHDB950C-1L	TBD	T7H1200E5W	KLR850BCB

Technical Data

Electrical and environmental data

Specification	Permitted Value
Electrical	
Input Voltage, 3-Phase	230 / 460 Vac
Input voltage deviation	±10% continuous, ±15% short time
Note: Special consideration must be given to voltage deviation in regeneration mode.	
Rated Frequency	50 Hz. or 60 Hz. ±2%
Environmental	
Cabinet internal ambient temperature	0 to 40°C
Change of ambient temperature	< 0.5°C
Relative humidity	5% to 95%, non-condensing
Site altitude	< 1000 m above sea level at 100% current > 1000 m above sea level at reduced current
Storage temperature	-40 to +55°C
Transportation temperature	-40 to +70°C

Reference DSC800 Hardware Manual *Technical Data*

Specifications

Environmental

Cabinet internal ambient temperature: 0 to 40 C
Protection Class: UL Type Open / IP00

Overload

150 pct of rated current for 60 seconds followed by 15 minutes at rated current or below

NOTE: Cannot be rerated for higher continuous current since all system components are sized based on these ratings

Input reactance

1.5 pct impedance when optional line reactor is included (available up to 150 hp)

NOTE: All drives require line reactor or dedicated isolation transformer with input impedance of 1.5 pct min; 4 to 10 pct max depending on system configuration. See "Line Reactors" in DCS800 Hardware Manual for details.

Fuse Protection

AC input line fuses (3)

DC output armature fuses, regen only (2)

Circuit breaker Protection (optional)

Instantaneous trip:

All Drives: Factory set at 300 pct of rated current

Thermal overload trip:

60 HP (DCS800-EP1-0125-05 and DCS800-EP2-0140-05) only: Factory set to 100 pct of rated current

Control transformer

10 – 150 HP: 250 VA, 230/460 Vac primary; 120 Vac secondary;

Available for customer use: zero Amps

AC or DC Contactor

10 – 300 HP: AC line contactor with (1) aux. N.O. contact for customer use: 6 Amps @ 24 – 127 Vac or 24 Vdc

400 – 600 HP: DC armature (DB) contactor, 3 pole (2 N.O. , 1 N.C. main contacts) with (1) aux. contact for customer use: 10 Amps @ 600 Vac or 0.2 Amps @ 600 Vdc

Accessories

Line reactors

External Line Reactors								
Non-Regenerative (2Q)	Regenerative (4Q)	HP	Line Reactor for Configuration A			Line Reactor for Configuration B		
			Manufactured by TCI					
			1.5% impedance	Watts Loss	Weight (Lbs.)	5% impedance	Watts Loss	Weight (Lbs.)
DCS800-EP1-0020-05	DCS800-EP2-0025-05	10	KLR16BTB	20	7	KLR16CTB	58	12
DCS800-EP1-0045-05	DCS800-EP2-0050-05	20	KLR35BTB	55	8	KLR35CTB	97	22
DCS800-EP1-0065-05	DCS800-EP2-0075-05	30	KLR45BTB	59	8	KLR45CTB	118	24
DCS800-EP1-0090-05	DCS800-EP2-0100-05	40	KLR55BTB	70	11	KLR55CTB	150	32
DCS800-EP1-0125-05	DCS800-EP2-0140-05	60	KLR110BCB	95	26	KLR110CCB	191	50
DCS800-EP1-0180-05	–	75	KLR110BCB	95	26	KLR110CCB	191	50
–	DCS800-EP2-0200-05	100	KLR160BCB	127	47	KLR160CCB	254	84
DCS800-EP1-0230-05	DCS800-EP2-0260-05	125	KLR200BCB	135	53	KLR200CCB	337	110
DCS800-EP1-0315-05	DCS800-EP2-0350-05	150	KLR200BCB	135	53	KLR200CCB	337	110
DCS800-EP1-0405-05	DCS800-EP2-0450-05	200	KLR300BCB	216	54	KLR300CCB	443	122
DCS800-EP1-0470-05	DCS800-EP2-0520-05	250	KLR360BCB	221	65	KLR360CCB	406	156
DCS800-EP1-0610-05	DCS800-EP2-0680-05	300	KLR420BCB	275	85	KLR420CCB	500	160
DCS800-EP1-0740-05	DCS800-EP2-0820-05	400	KLR600BCB	338	96	KLR600CCB	650	275
DCS800-EP1-0900-05	DCS800-EP2-1000-05	500	KLR750BCB	372	147	KLR750CCB	732	295
–	DCS800-EP2-1010-05	600	KLR850BCB	389	150	KLR850CCB	850	300

Diagrams

Power

Power Diagram P1 – Frames A & B

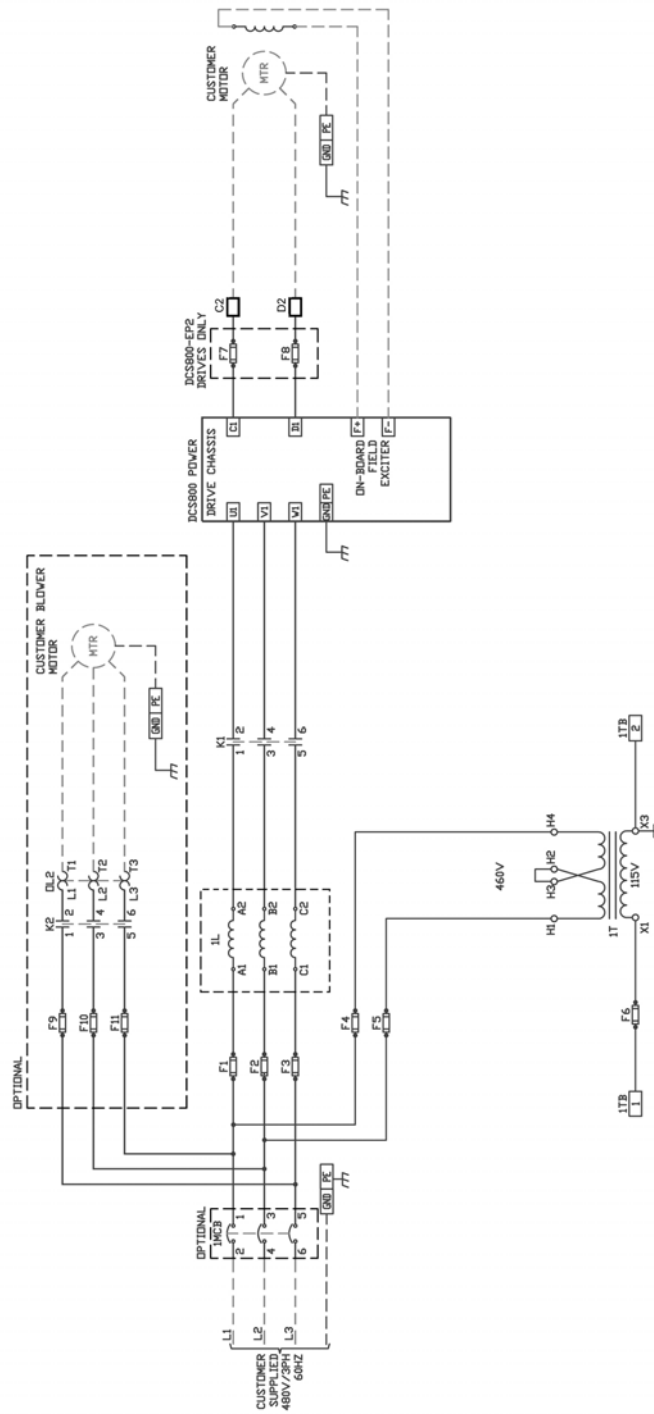

Power Diagram P2 – Frame C

NOT AVAILABLE

Power Diagram P3 – Frame D

NOT AVAILABLE

Control

Control Diagram C1 – Frames A . . . C

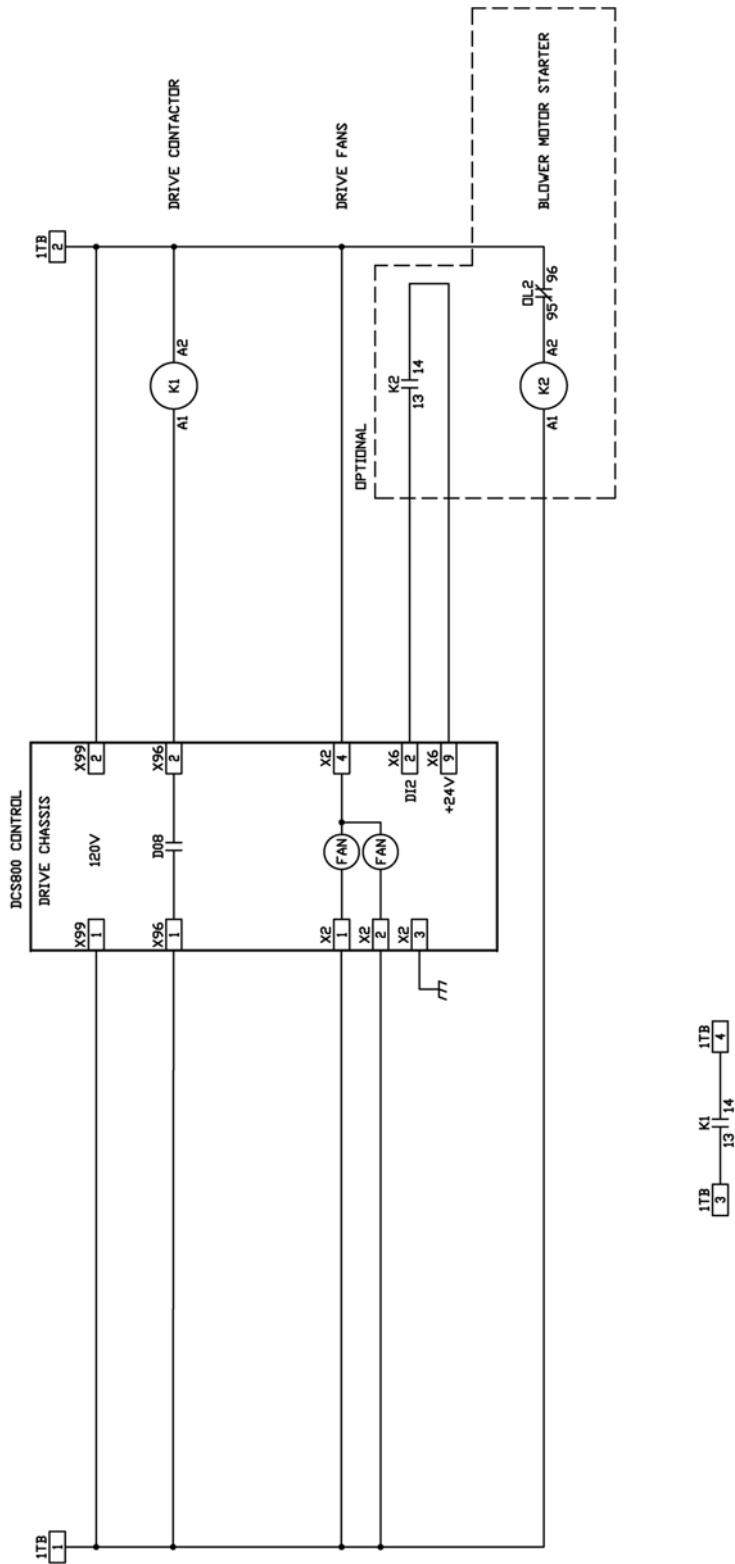

Control Diagram C12 – Frame D

NOT AVAILABLE



Index

	Numerics		
230 Vac operation		24	Insulation check
	A		I/O programming
Accessories		33	
Air flow		13	L
Analog inputs		23	Line reactors
	B		Low voltage configuration
Blower motor starter		30	
	C		M
Cabinet mounting		12	Mechanical installation
Cable sizing		16	Mechanical installation warnings
Checklist		25	
Clearances		12, 13	N
Connection diagrams		21, 22	Nameplate
Connector locations		19	
Connectors		19	O
Control circuit connections		23	Operation
Control circuit inputs		23	
Control diagrams		37, 38	P
Control transformer		24	Panel photographs
Cooling air		12, 13	Parameter settings
	D		Planning the electrical installation
Delivery check		11	Plus codes
Digital inputs		23	Power diagrams
Dimensional data		26	
Dimensional drawings		27	R
	E		Reactors
Electrical diagrams chart		20	Replacement parts
Electrical installation		17	
Electrical specifications		31	S
Environmental specifications		31	Safety instructions
	F		
Factory options		10	T
Fuses		29	Table of contents
	G		Technical data
Grounding		3, 18	Tightening torque
	H		Type codes
Heat dissipation		13	
	I		U
Installation checklist		25	Ungrounded systems
Installation warnings		2	
			V
			Voltage specification
			W
			Warnings
			Watts loss





ABB Inc.
Automation Products
Low Voltage Drives
16250 West Glendale Drive
New Berlin, WI 53151
Telephone 262 785-3200
Fax 262 780-5135
Internet www.abb.us/drives
www.abb-drives.com

3AUA0000076338 REV A
Effective 03/01/2010
Subject to change without notice.
All rights reserved.