

| | | |
|---|--|--------------------------|
|  New Berlin, WI | DCS800-EP 230V Conversion Kit | Doc. No.: 3AUA0000077439 |
| | | Revision: A |

**Instructions on how to convert
460 Volt DCS800-EP panel drive for 230 Volt operation**

IMPORTANT

Refer to the DCS800-EP Installation and Start Up Manual and the DCS800 Hardware or Firmware manuals for detailed information on drive installation and operation.

The following table identifies the proper kit to convert the listed drive panel to 230 Volt operation. Make certain that you have the proper kit for your drive.

| Drive Panel Type Code | | Conversion Kit |
|--------------------------|----------------------|------------------|
| Non-Regenerative (2Q) | Regenerative (4Q) | |
| DCS800-EP1-0020-05 | DCS800-EP2-0025-05 | 230 VAC Supply-1 |
| DCS800-EP1-0045-05 | DCS800-EP2-0050-05 | 230 VAC Supply-1 |
| DCS800-EP1-0065-05 | DCS800-EP2-0075-05 | 230 VAC Supply-1 |
| DCS800-EP1-0090-05 | DCS800-EP2-0100-05 | 230 VAC Supply-1 |
| DCS800-EP1-0125-05 | DCS800-EP2-0140-05 | 230 VAC Supply-1 |
| DCS800-EP1-0180-05 | - | 230 VAC Supply-1 |
| - | DCS800-EP2-0200-05 | 230 VAC Supply-1 |
| DCS800-EP1-0230-05 | DCS800-EP2-0260-05 | 230 VAC Supply-1 |
| DCS800-EP1-0315-05 | DCS800-EP2-0350-05 | 230 VAC Supply-1 |
| DCS800-EP1-0405-05 | DCS800-EP2-0450-05 | 230 VAC Supply-2 |
| DCS800-EP1-0470-05 | DCS800-EP2-0520-05 | 230 VAC Supply-2 |
| DCS800-EP1-0610-05 | DCS800-EP2-0680-05 | 230 VAC Supply-2 |
| DCS800-EP1-0740-05 | DCS800-EP2-0820-05 | 230 VAC Supply-2 |
| DCS800-EP1-0900-05 | DCS800-EP2-1000-05 | 230 VAC Supply-2 |
| - | DCS800-EP2-1010-05 | 230 VAC Supply-2 |

Note: *If "+S235" suffix is shown on the product type code (as shown on panel ratings nameplate), then it has been factory configured for 230 Vac operation.*

| | | |
|---|--|--------------------------|
|  New Berlin, WI | DCS800-EP 230V Conversion Kit | Doc. No.: 3AUA0000077439 |
| | | Revision: A |

INTRODUCTION

Reconfiguring a 460 Vac DCS800-EP panel drive for 230 Vac operation can be easily accomplished by using a conversion kit and following the steps below. These steps are intended as a guide and may not cover all required changes for every application. It is the user's responsibility to consider all conditions before restarting the application.



Important! Only qualified electricians are allowed to install and maintain the drive. Never work on the drive, motor cable or motor or attempt reconfiguration when power is applied.



Most DCS800-EP panel drives are shipped ready for 460 Vac input power connection. Panel drives that are prewired for 230 Vac are clearly marked with a sticker on the panel ratings nameplate or with the suffix "+S235" in the product type code. These instructions do not apply to drives already configured for 230 Vac operation.

Panel A - DCS800-EPx-020-05 thru DCS800-EPx-140-05

The Control Circuit transformer is located under the DCS800 drive module.

1. If the DCS800-EP panel drive is already installed, disconnect and lock out all sources of power.
2. Remove the cover from the DCS800 module by removing the control panel and pressing down on the two tabs at the lower corners with a screwdriver.

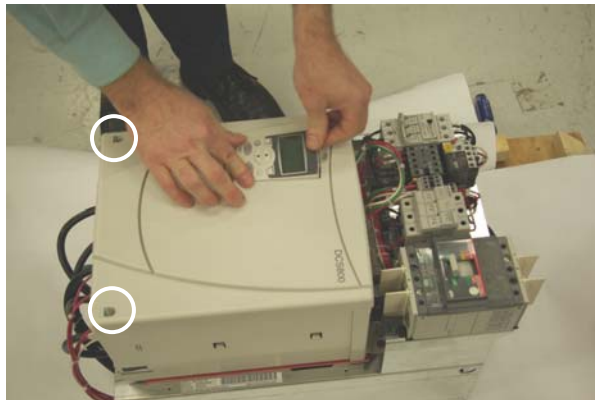

3. Disconnect the (5) pull-apart control terminal blocks as shown. Then disconnect (1) pull-apart terminal block at the top of the drive module for the fans. (not shown)



4. Remove the (4) drive module mounting screws and carefully move the module to allow access to the control circuit transformer. Avoid unnecessary stress on any power or control wires.

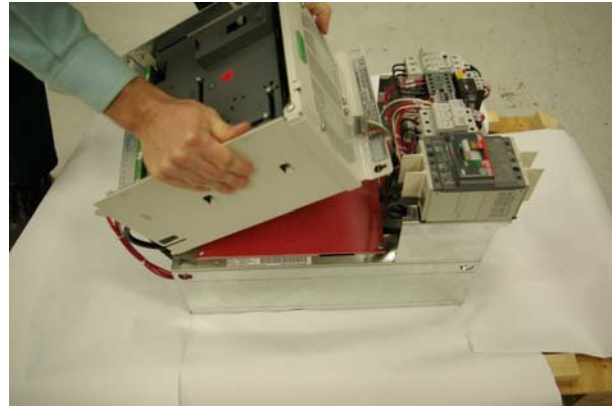

5. Remove insulator plate by unscrewing the (4) mounting screws.

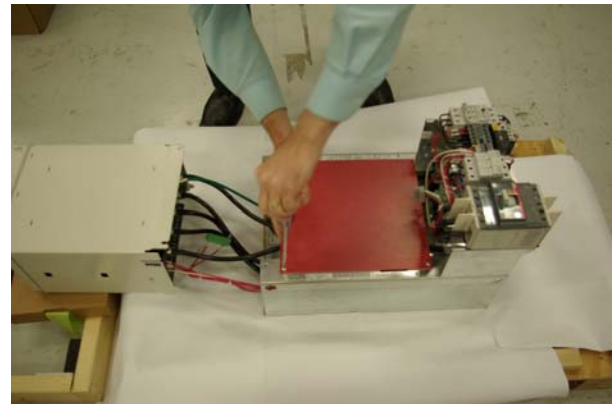

- Remove the jumper between H2 and H3, noting that this is actually two jumpers stacked together. Separate the two and jumper H1 to H3 and H2 to H4. Confirm that all connections are tight.

See wiring diagram on page 7.

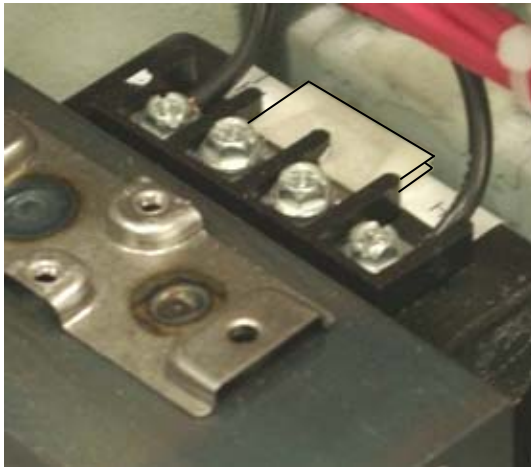
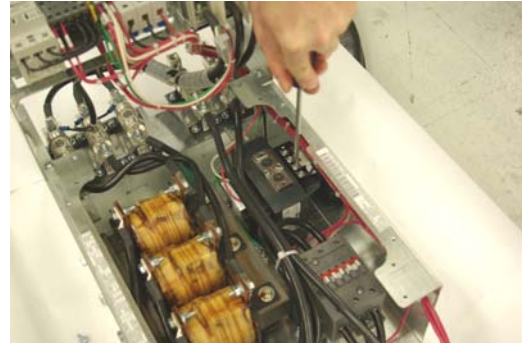

Before (460V)



After (230V)

- Secure the insulator plate using the (4) mounting screws. Replace the drive module to its original position and replace the (4) mounting screws. Confirm that the screws are tight.
- Reconnect the (5) pull apart terminal blocks removed in step 3, and the fan terminal block on top of the drive module. Then replace the drive module cover, secure, and replace the control panel.

The control circuit transformer fuses are located above the drive module and are marked F4, F5 and F6.

- Pull the F4 and F5 fuse holders open and replace the (2) FNQR 1-1/8 with the (2) FNQR 2 supplied in the kit. Close the holders when finished.
- Affix the "wired for 230Vac" label near the ratings nameplate located to the left of the drive module.

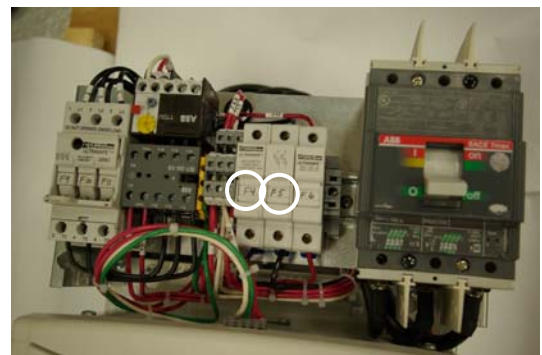
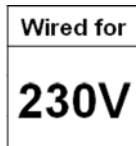

Panel A – Test and Setup



Important! Only qualified electricians are allowed to install and maintain the drive. Do not proceed to additional steps until the correct wiring is complete.

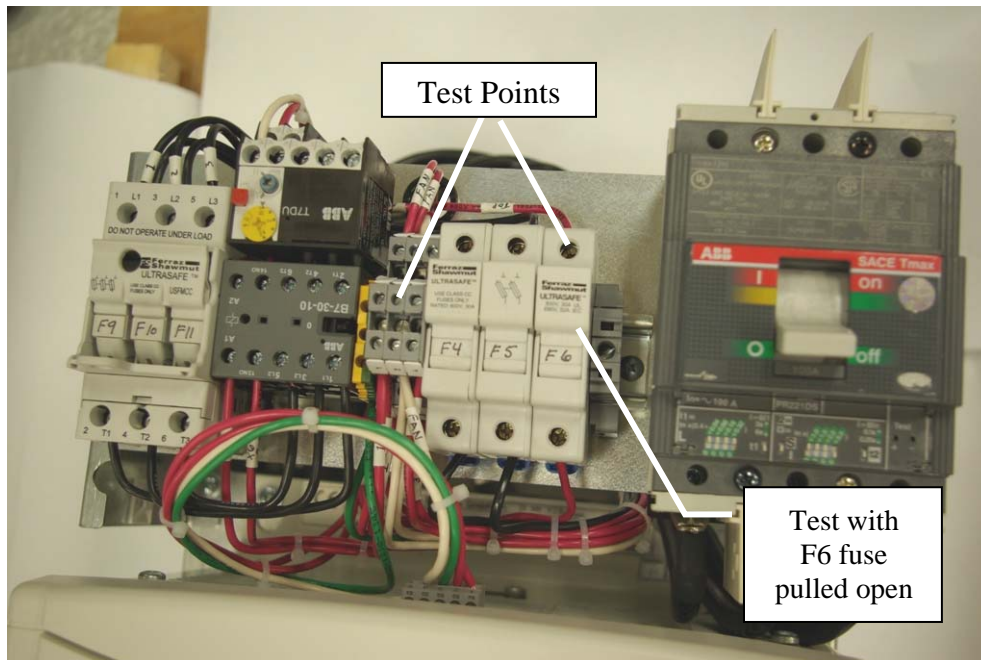

11. Pull the F6 fuse holder open to disconnect the secondary from the drive logic.
12. Apply 230 Volts AC to the drive panel. Using an appropriate VOM, confirm that the control transformer secondary voltage is 110 Volts AC as measured between the top of **F6** and **panel terminal #2**. If the correct voltage is present, close the fuse holder to reconnect the secondary to the drive logic.
13. **SETUP:** Access the drive programming via the Control Panel and change parameter 99.10 (Nominal AC mains voltage) to a value of "230".
14. The drive panel is now ready for operation on 230 Volts ac.

Panel B - DCS800-EPx-180-05 thru DCS800-EPx-350-05

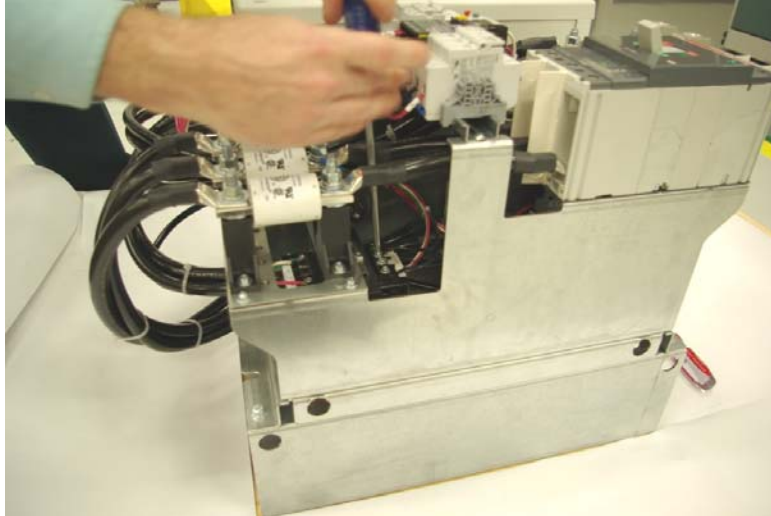

The control circuit transformer is located behind the main ac input fuses (F1,F2,F3) . Access to the jumpers is above the main fuse mounting plate.

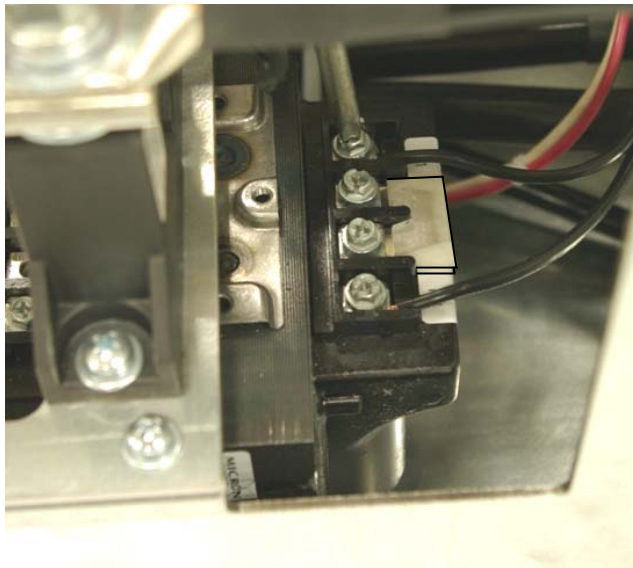

Before (460V)

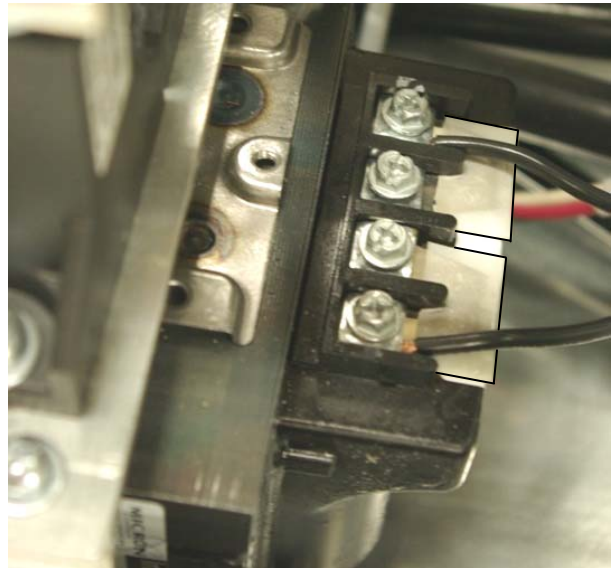

After (230V)

1. If the DCS800-EP panel drive is already installed, disconnect and lock out all sources of power.
2. Remove the jumper between H2 and H3, noting that this is actually two jumpers stacked together. Separate the two and jumper H1 to H3 and H2 to H4. Confirm that all connections are tight.

See wiring diagram on page 7.

Control transformer fuses are located directly above the main fuses and are marked F4, F5 and F6.

3. Pull the F4 and F5 fuse holders open and replace the (2) FNQR 1-1/8 with the (2) FNQR 2 supplied in the kit. Close the holders when finished.
4. Affix the "wired for 230Vac" label near the ratings nameplate located above the drive module.

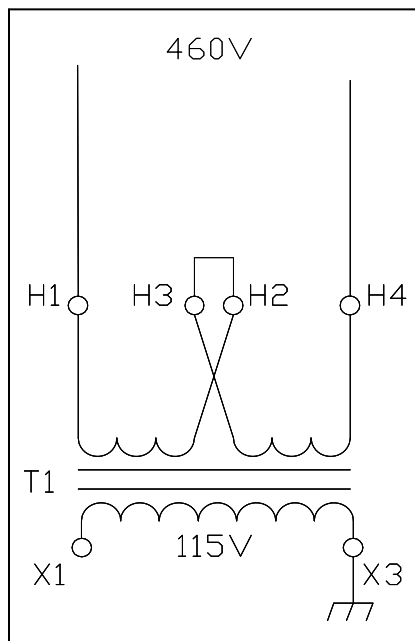
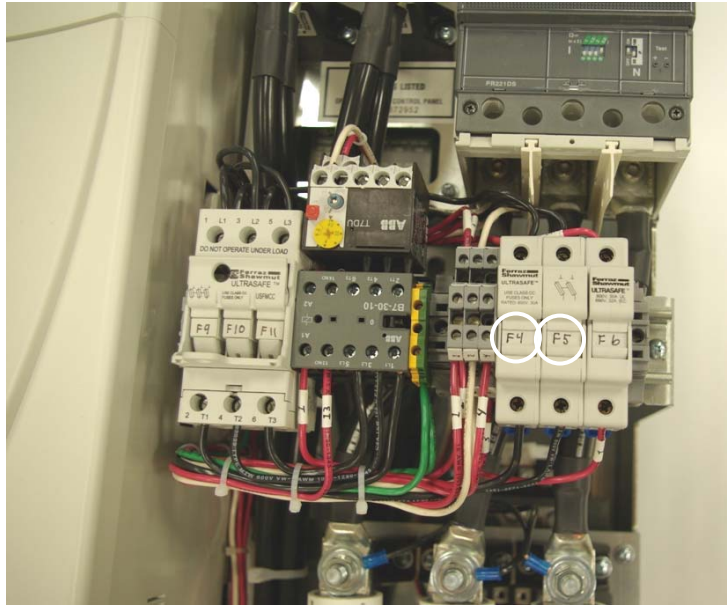
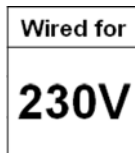

Factory 460V connection

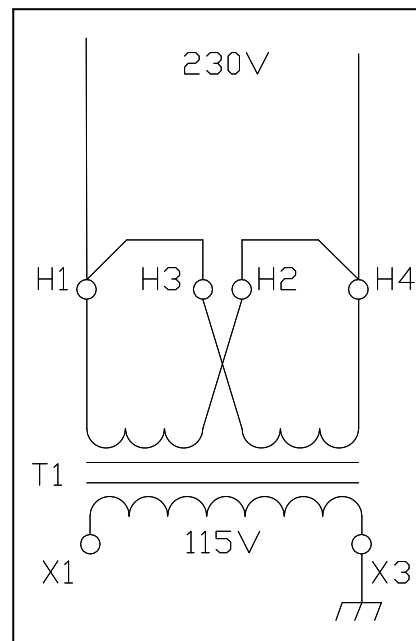

230V reconnection

Panel B – Test and Setup



Important! Only qualified electricians are allowed to install and maintain the drive. Do not proceed to additional steps until the correct wiring is complete.

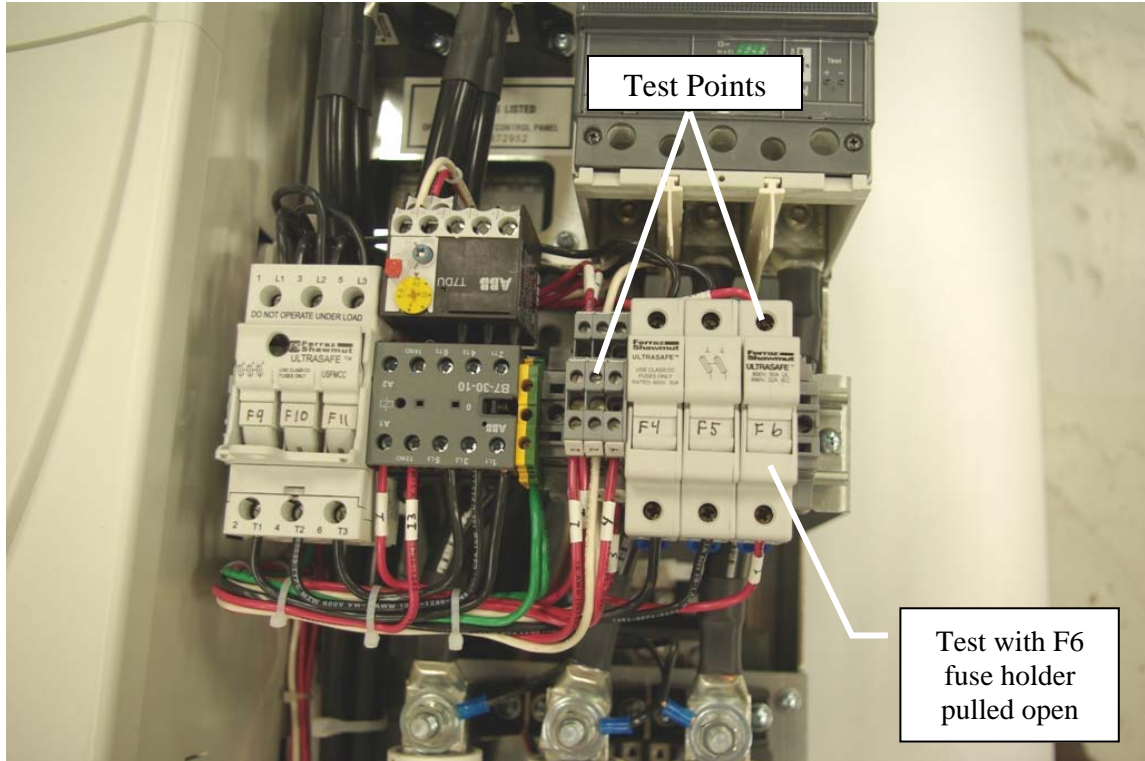

5. Pull the F6 fuse holder open to disconnect the secondary from the drive logic.
6. Apply 230 Volts AC to the drive panel. Using an appropriate VOM, confirm that the control transformer secondary voltage is 110 Volts AC as measured between the top of **F6** and **panel terminal #2**. If the correct voltage is present, close the fuse holder to reconnect the secondary to the drive logic.
7. **SETUP:** Access the drive programming via the Control Panel and change parameter 99.10 (Nominal AC mains voltage) to a value of "230".
8. The drive panel is now ready for operation on 230 Volts ac.