

What's New?

RobotStudio

5.14.01 SP1

Revision: -

The information in this manual is subject to change without notice and should not be construed as a commitment by ABB. ABB assumes no responsibility for any errors that may appear in this manual.

Except as may be expressly stated anywhere in this manual, nothing herein shall be construed as any kind of guarantee or warranty by ABB for losses, damages to persons or property, fitness for a specific purpose or the like.

In no event shall ABB be liable for incidental or consequential damages arising from use of this manual and products described herein.

This manual and parts thereof must not be reproduced or copied without ABB's written permission, and contents thereof must not be imparted to a third party nor be used for any unauthorized purpose. Contravention will be prosecuted.

Additional copies of this document may be obtained from ABB at its then current charge.

© Copyright 2011 ABB All rights reserved.
ABB AB
Robotics Products
SE-721 68 Västerås
Sweden

1 What's New in 5.14.01 SP1?

Overview

This section provides information about the new features and problems corrected in this release.

1.1 Solved Issues

Two different memory problems are resolved in this Service Pack:

The first issue, addressing the problem that the size of the station is increased with every save. This was primarily a problem for stations with lots of graphical components (geometry) that would result in an increase of the station file size for each save.

The second issue concerned libraries that was connected and then disconnected. This could in some cases cause a memory exception.

2 What's New in 5.14.01?

Overview

This section provides information about the new features and problems corrected in this release.

2.1 Online Monitor

The parameters for defining update rate, warning and error levels for joint limits and singularities has been added to the RobotStudio Options pages.

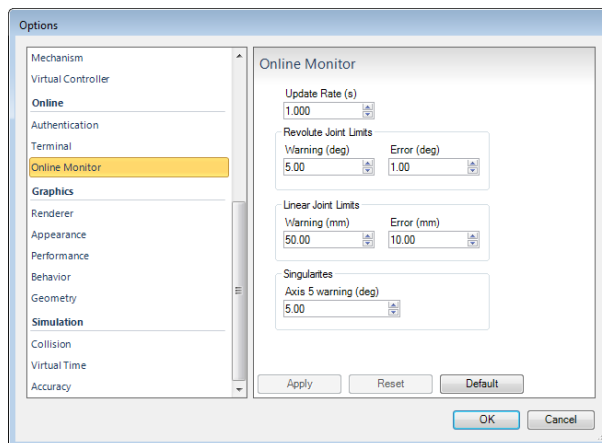

2.2 AutoPath

The AutoPath feature can be used to create a path based on the edges of the surfaces of a part. The function only allows a path to be created along adjacent faces. The parameter that defines the maximum distance between two faces to be considered adjacent has been added to the RobotStudio Options page.

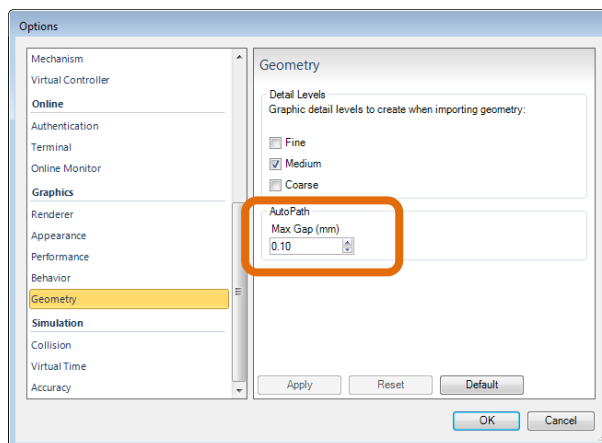

2.3 Collada import and export

RobotStudio can now import files in the format Collada version 1.4.1 (.dae) using the function **Import Geometry**. Objects can be exported in the Collada format using the function **Export Geometry**. The static geometry of an entire station can be exported in the collada format by selecting the station node of the **Layout** browser and selecting **Export Geometry**.

2.4 Measurement markup

The x,y,z values of a measurement are displayed in a markup together with the total distance.

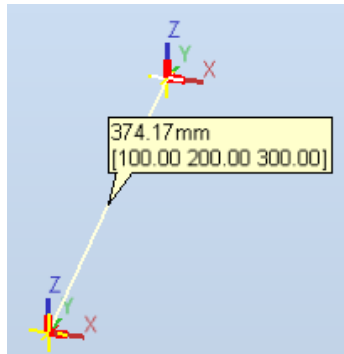

2.5 Access Level ALL no longer needed of input signals

Signals of a VC no longer need to be defined to have **Access Level = ALL** in the I/O Configuration database to change its values from RobotStudio. It is sufficient to have them defined with **Access Level = DEFAULT**.

2.6 Preview image of Pack & Go files

A preview image of the station contained in a Pack&Go file will be displayed in the preview pane of Windows Explorer in Windows 7.

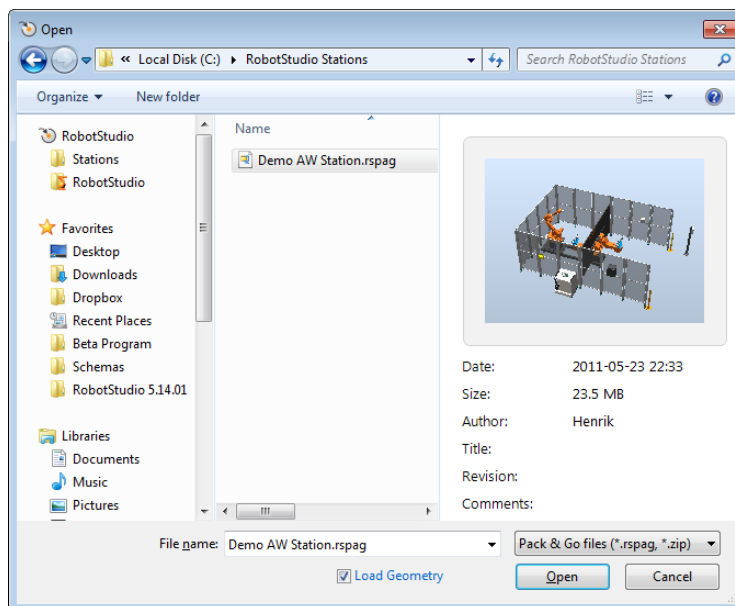

2.7 New robot models – IRB5300-12

The IRB5300-12 (the so-called *door opener*) is available in RobotStudio 5.14.01

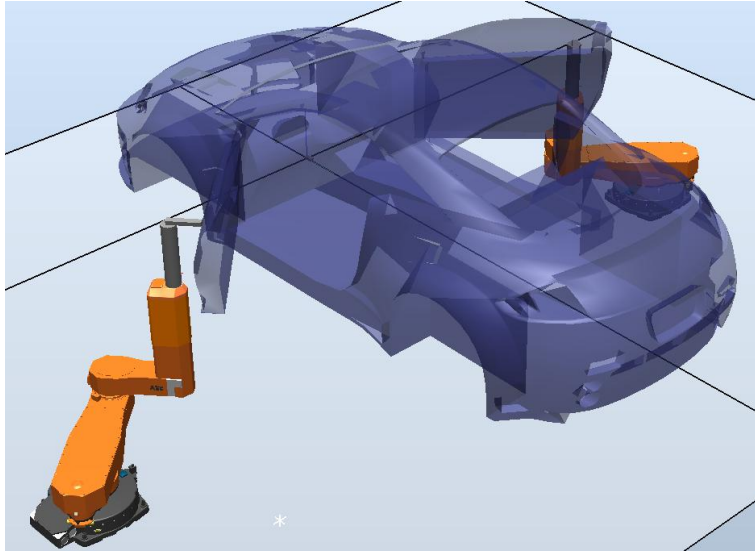

3 What's New in 5.14?

Overview

This section provides information about the new features in RobotStudio 5.14.

3.1 Microsoft Office 2010 Fluent User Interface

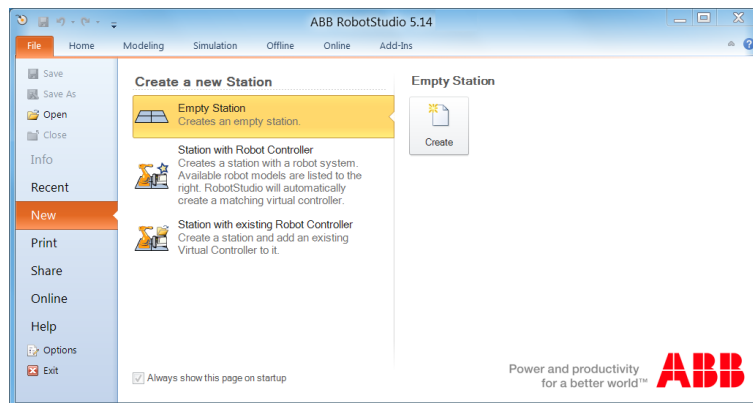

Fluent UI

The RobotStudio 5.14 user interface is redesigned and now uses the Microsoft Office Fluent user interface (UI). Introduced in the RobotStudio 5.11, the Fluent UI is designed to make it easier for people to find and use the full range of features that RobotStudio provide, and to preserve an uncluttered workspace.

The Ribbon

The ribbon, part of the Fluent UI, was designed to optimize key RobotStudio scenarios to make them easier to use. The ribbon provides quicker access to all the commands in RobotStudio and allows for easier future additions and customizations. You can make your favorite commands available in the quick access toolbar, embedded in the title bar. To help maximize the space of the graphical viewer, the ribbon can be hidden.

Backstage View

The Microsoft Office Backstage is part of the Fluent UI and a companion feature to the ribbon. The Backstage view, which can be accessed from the **File** menu, helps you find frequently used features for managing RobotStudio files. (The **File** tab replaces the RobotStudio Button and **File** menu that were used in earlier releases of RobotStudio.)

3.2 Activation and Licensing

Version independent activation key: *RobotStudio 5.x*

Starting with RobotStudio 5.14, the activation key that activates RobotStudio 5.14 will also activate all future versions (both major and minor) of RobotStudio 5. This is indicated by the version of the installed license key in RobotStudio. The version displayed in the license information dialog is now **5.x**.

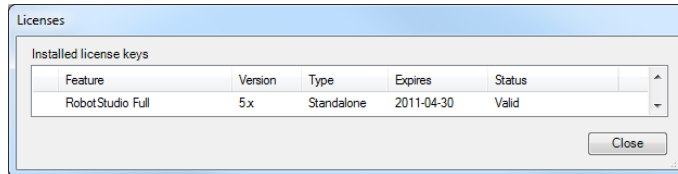

3.3 General

Document Manager References

References to files and folders can be added to a station through the **Document Manager**. Referenced folders can optionally be included in the Pack and Go file. There is also an option to completely embed a file in the station.

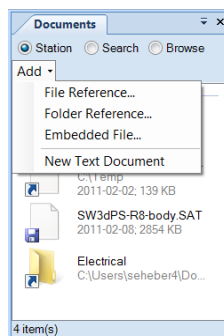

New Robot Models

Simulation models for the following new robots have been added to RobotStudio

- IRB2600ID (15kg/1.85m)
- IRB2600ID (8kg/2.0m)
- IRB460
- IRB760

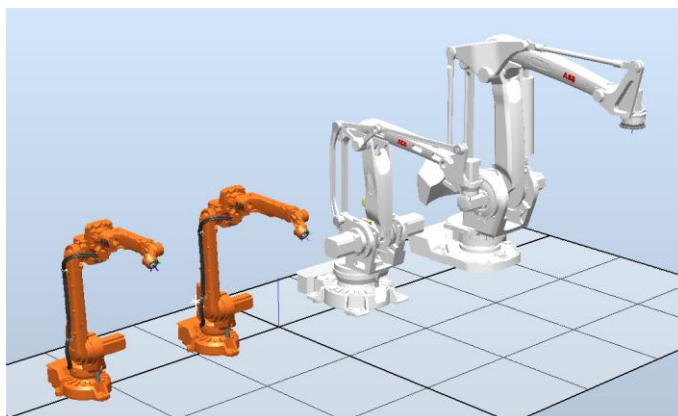

Station name in title bar

The name of the currently opened station has been added to the title bar.

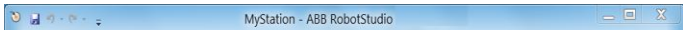

Improvements of CAD based path generation (AutoPath)

The function 'Path from Curve' for automatic creation of path based on a curve, has been improved. It is not longer required to have a curve prepared as it can work on the edges of a piece of geometry. Of course, if a curve is available, it can be used for the path generation as before. The user interface has been simplified and advanced options for angle tuning, approach and depart targets removed. Also, a preview of the path is available to indicate what the result will be before the command is executed.

Tuning of targets can be done through the new **Reference Frame** available in the **Set Position** and **Rotate** tools. Approach and depart targets can be created using the regular copy/paste functions in combination with the tuning feature. The function has been renamed to **AutoPath** to reflect the re-design.

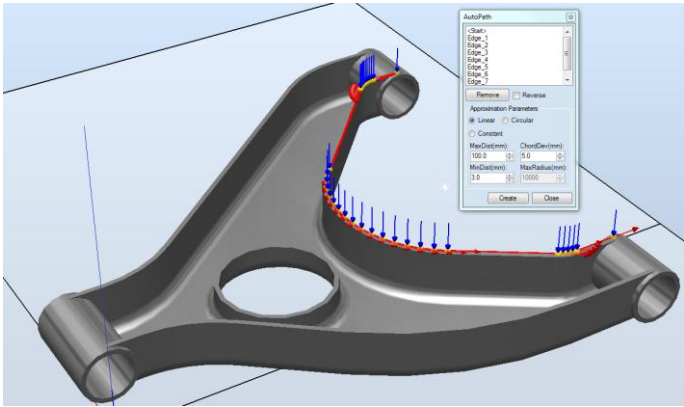

Online Monitor

The Online Monitor can be described as a virtual web camera that monitors the connected robot and visualizes its movements. The graphical view that shows the robot model is updated with the true robot position every second. If the robot is in a singular position or at a joint limit you will get an indication in the view. Only TCP robots will be shown as external axes are not supported.

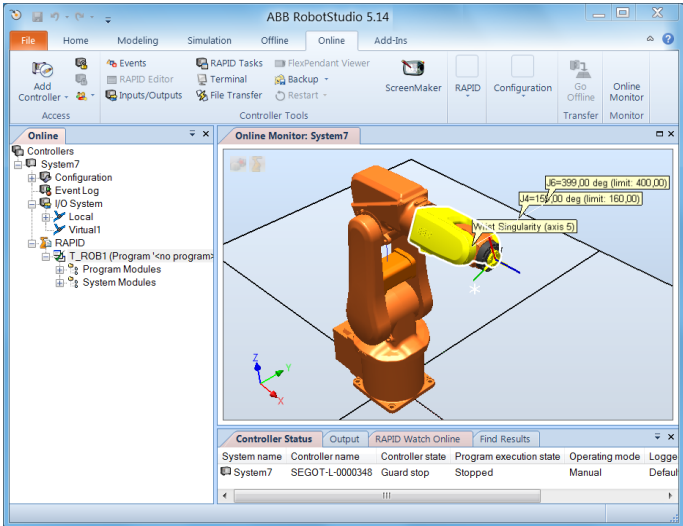

Adjust Robtargets

The Premium feature **Adjust Robtargets** allows programs that has been programmed with the wrong TCP (tooldata) or work object (wobjdata) to be corrected. The joint angles of the robot will remain the same.

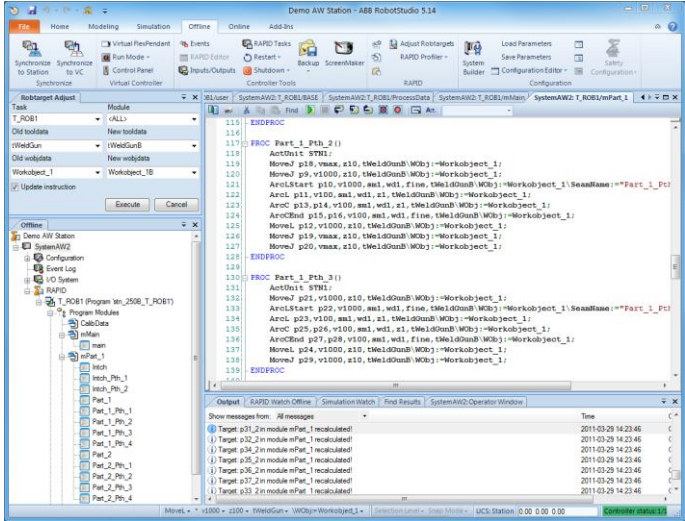

Accelerated simulation

An option to run the simulation as fast as possible has been added to the Simulation Accuracy section of the RobotStudio options. With this option selected, RobotStudio will fire the next time step as soon as the calculation for the previous one is completed. The predicted execution times for the Virtual Controllers will not be affected.

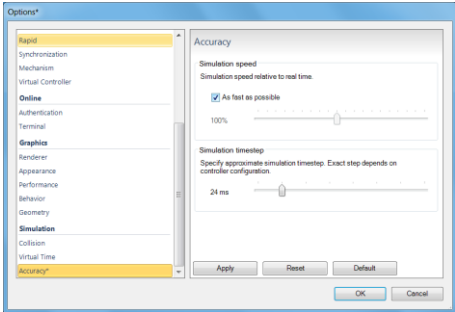

Station Viewer Improvements: Acceleration and Seek Bar

The simulation replay of the **Station Viewer** can now accelerated up to 200% of the normal execution speed. It is also possible to reduce the time or even play the simulation backwards. In addition, a seek bar has been added that shows simulation progress and allows the simulation to be started at a particular point.

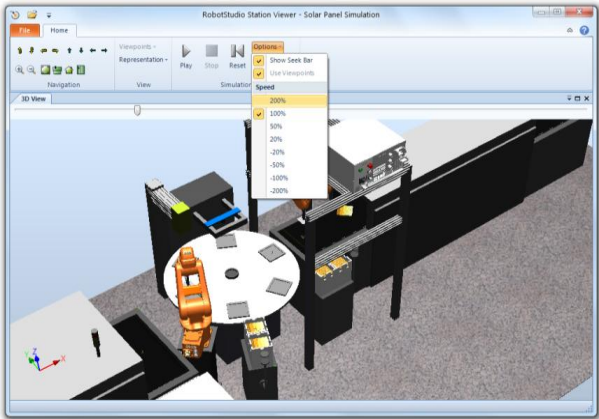

Simulation Step / Pause / Resume

A simulation can now be stepped forward one tick at the time. First, start the simulation as usual by pressing the **Play** button. Then, you can pause the simulation by pressing the **Pause** button. When paused, the **Play** button will be renamed to **Resume**, and the **Pause** button will be renamed into **Step**. Now, the simulation can be stepped forward one time step (tick) at the time by pressing the **Step** button.

Before starting the simulation the **Play** button is enabled. When the simulation is running, the **Pause** button is enabled. When paused, the **Play**, and **Pause** buttons are renamed, **Resume** and **Step**, respectively, see below.



ScreenRecorder support for Microsoft Windows Media format

Support for Windows Media version 8 and 9 has been added to the **Screen Recorder**. In addition, movies can be recorded using the H.264 / MPEG-4 encoder that creates high-quality recordings with a high compression ratio. The AVI format is still available and allows the selection of any available codec on the computer.

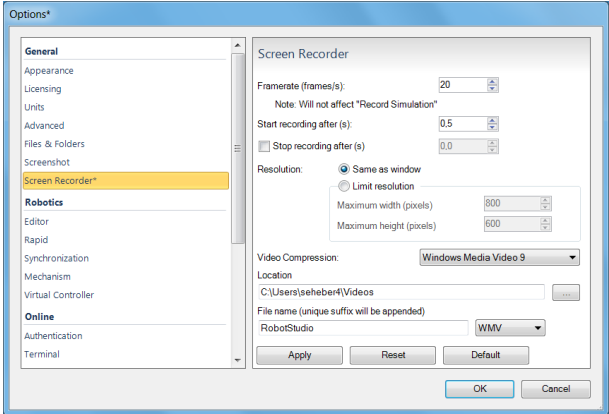

NOTE!

The Microsoft Windows Media and H.264 encoders are only available for Windows 7, not for Windows XP.

Transparent textures

To simplify modeling and increase realism, support for transparent textures has been added to RobotStudio. The textures are applied using the **Graphical Appearance** tool. The feature supports textures in .PNG format.

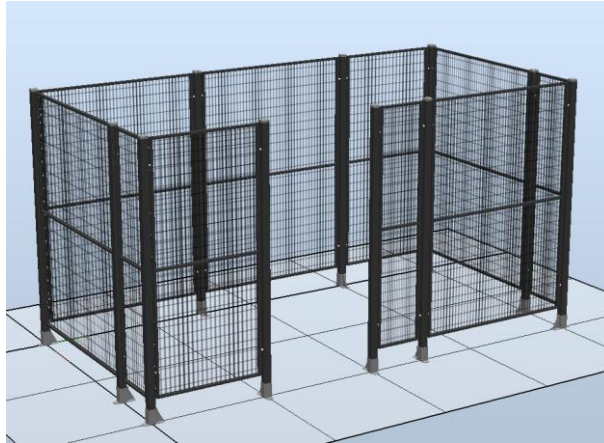

Target Reference Frame

The reference frame of a target has now been exposed in RobotStudio. Until now, it has only been available in ArcWelding PowerPac. The target reference frame allows a target to be offset relative to the original position. This is useful if the targets have been created using a CAD-model and it is required to offset the target position to compensate for the robot tool. The **Reference Frame** is available in the **Set Position** and **Rotate** tools

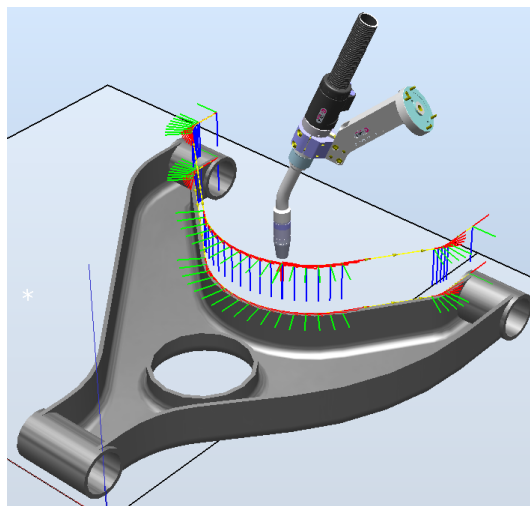

Improved performance for Configurations and AutoConfig

The different ways a robot arm can use to reach a certain target is controlled by the `confdata` in RAPID and can be set using the **Configurations** tool in RobotStudio. The performance of the calculation of the available arm configurations are now done directly by the virtual controller, which gives a dramatic increase in performance. The improved performance can be seen when using RobotWare 5.14.

Collision Detection performance improved.

The **Collision Detection** computation has been improved to make use of multiple CPU cores, if available, and uses the SSE (Streaming SIMD Extensions) instruction set for best performance.

Nine decimals in generated RAPID code

The number of decimals used for specifying the position and orientation data of generated `robtargets`, `tooldata`, and `wobjdata` are now limited to nine. This will increase readability of the generated RAPID code. Accuracy is not affected since the data is declared in RAPID as `num` (single precision) that uses the eight first decimals.

Markups

A markup is a text box displayed in the 3D graphics. It can be used to highlight areas of interest. Markups become part of the Station Viewer.

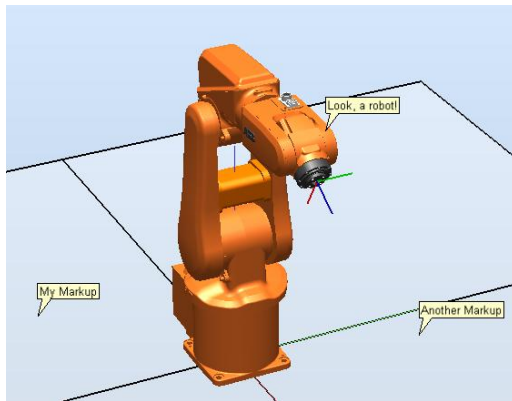

AutoConfig options

New options related to **AutoConfig**

- **Verify.** Verifies existing configuration
- **Reset.** Marks current configuration as unverified to enable for optimization using **AutoConfig**

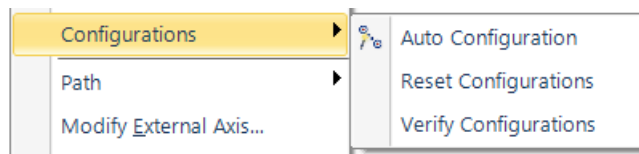

Signal Analyzer

Signals to be analyzed are defined in the **Signal Setup** tool for viewing and analysis in the **Signal Analyzer**. The tool allows robot performance tuning and signal debugging.

The table below lists the signals that can be analyzed and their dependency on RobotWare..

Signal name	RW availability
<i>Controller Signals / <system name> / EventLog</i>	
<domain>	Any RW version
<i>Controller Signals / <system name> / Mechanical Units / I/O System</i>	
<all signals>	Any RW version
<i>Controller Signals / <system name> / Mechanical Units / ROB_x / Joint</i>	
J1-J6	Any RW version
Near Limit	Any RW version
<i>Controller Signals / <system name> / Mechanical Units / ROB_x / Target</i>	
Fine Point	Any RW version
Target Reached	Any RW version
<i>Controller Signals / <system name> / Mechanical Units / ROB_x / TCP</i>	
Maximum Linear Acceleration in World ¹	RW version ≥ 5.14
Orientation Q1-Q4 Current Workobject	RW version ≥ 5.14
Orientation Speed in Current Workobject	RW version ≥ 5.14
Pos X, Y, Z in Current Workobject	RW version ≥ 5.14
Robot Configuration cf1, cf4, cf6, cfx	RW version ≥ 5.14
Speed in Current Workobject	RW version ≥ 5.14
Total Motor Power	RW version ≥ 5.14
<i>Smart Components</i>	
<all signals>	<no RW needed>

The Signals are visualized in the graph below.

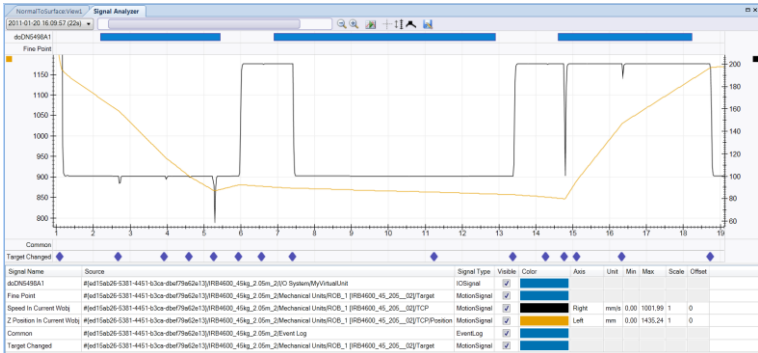

Using the Signal History tool, signal recordings can be exported to Excel, renamed, or deleted.



NOTE!

The maximum number of signals that can be exported is limited to 26.

¹ The signal 'Maximum Linear Acceleration in World' provides the maximum acceleration of the current move instruction.

RAPID Profiler

The new **RAPID Profiler** is a tool for measuring and analyzing procedure execution times of the robot program. It is a Premium feature that can be used to identify the critical procedures that offer great potential for cycle time reduction. Special attention is paid to Wait-instructions and MultiMove synchronization semaphores. Reducing waiting times is the obvious way to reduce the program execution time.

Task	Procedure	Time (incl subs)	Time (excl subs)
T_ROB1	PickPanel	85.2 % [35111 ms]	85.2 % [35111 ms]
T_ROB1	PlacePanelOnOutFeeder	9.1 % [3733 ms]	9.1 % [3733 ms]
T_ROB1	PlacePanelInControlBuffer	5.7 % [2345 ms]	5.7 % [2345 ms]

Task	Procedure	Instruction	Time
T_ROB1	PickPanel	WaitDI dCellInPickPos.1:	27821 ms
T_ROB1	PickPanel	WaitDI dCellInPickPos.1:	3261 ms
T_ROB1	PickPanel	WaitDI dCellInPickPos.1:	1248 ms
T_ROB1	PickPanel	WaitDI dVacuum.1:	44 ms
T_ROB1	PickPanel	WaitDI dVacuum.1:	44 ms
T_ROB1	PlacePanelOnOutFeeder	WaitDI dVacuum.0:	41 ms
T_ROB1	PlacePanelInControlBuffer	WaitDI dVacuum.0:	37 ms
T_ROB1	PickPanel	WaitDI dVacuum.1:	28 ms
T_ROB1	PlacePanelOnOutFeeder	WaitDI dVacuum.0:	28 ms



NOTE!

- The Spy function does not produce useful output for systems based on the RobotWare option CAP (Continuous Application Platform). This is the case for e.g. systems with ArcWelding. This affects the RAPID Profiler that analyses the log generated by the Spy function.
- For accurate results, the last move instruction of all procedures should be a fine point. Otherwise the estimated time for that procedure will be underestimated.

External axis interpolation

Defines optimal external axis value with respect to robot TCP

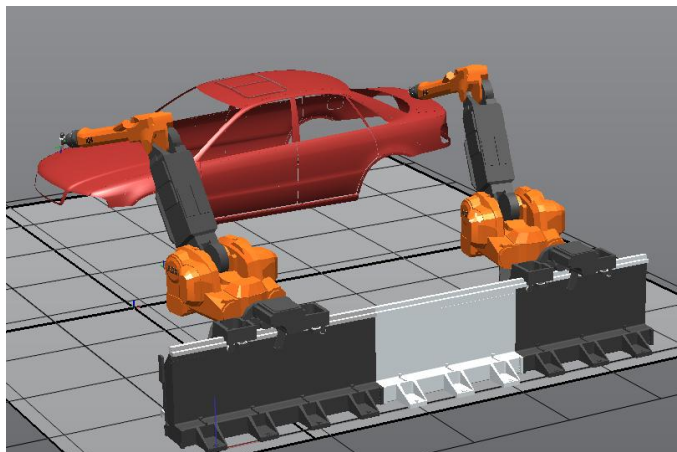

3.4 Smart Component Improvements

Smart Component: LogicExpression

A gate whose output is determined by a logic expression. Supports logic operators AND, OR, NOT and XOR. Advanced gates can be easily created using the LogicExpression gate. The overall complexity of a smart component is reduced since the gate logic can be handled by one base component.

Example: output = input5 XOR (input1 AND input2) OR (NOT input3)

Smart Component Viewer Filter

The objects of the SmartComponent viewer can now be filtered to reduce the complexity.

- signals
- properties
- only connected components

Property *Detectable* added to graphical objects

Allows graphical objects to be made invisible to SmartComponent sensors

3.5 ScreenMaker Improvements

Language Support

ScreenMaker supports the same set of languages that RobotStudio supports. The languages are applicable for the User Interface which includes the ribbon and dialogs and not for the controls and its properties .

ScreenMaker Templates

ScreenMaker now includes the three templates **Basic**, **Advanced** and **Extended**, which represent typical uses of ScreenMaker.

Launch Virtual Flexpendant after deploying

The new option to automatically launch the Virtual FlexPendant after the current ScreenMaker application have been deployed is available in the ScreenMaker properties.

Access of shared data

Shared RAPID data can now be accessed using ScreenMaker

Conditional Trigger Control

A new control for configuring the execution of events based on condition. The following table describes the conditions and datatypes supported

Condition	RAPID	Signals	Application Variables
AND	bool	NA	bool
OR	bool	NA	bool
XOR	bool	NA	bool
NOTEQUAL	Any Type	Any Type	Any Type
EQUAL	Any Type	Any Type	Any Type
GREATER	num, dnum	num, dnum	num, dnum (0/1)
LESSER	num, dnum	num, dnum	num, dnum(0/1)

ScreenMaker Doctor detects missing RAPID and Signal data

The **ScreenMaker Doctor** now detects missing RAPID and Signal data that has been bound in the ScreenMaker project but does not exist in the connected controller. The ScreenMaker project must be connected to the controller to detect RAPID and Signal data. The ScreenMaker Doctor does not detect actions that are defined as part of events. For example: If an action has been defined to Read Rapid Data into Application Variable.

Increment / Decrement control

A new control for incrementing and decrementing a NUM/DNUM.