

IRB 7600 Industrial Robot

Main Applications
Machine tending
Material handling
Press tending
Spot welding



Introducing the Power Robot

A new world of possibilities opens up with ABB's new power robot family. It comes in five versions, 500 kg, 400 kg, 340 kg and 150 kg handling capacities. The IRB 7600 is ideal for weighty applications, regardless of industry. Typical areas can be handling of heavy fixtures, turning car bodies, lifting engines, handling heavy parts in foundries or forges, loading and unloading of machine cells, alternatively handling large and heavy pallet layers.

A safe investment

A major concern with robots handling payloads of up to 500 kg will be to safeguard your personnel in the unlikely event of an accident, as well as to protect the robot itself and your investment.

We have therefore added a range of software products all falling under the umbrella designator of Active Safety.

Service information

A built-in Service Information System monitors the motion and load of the machine and optimizes service requirements by itself.

Active safety features

Collision detection reduces the collision force substantially. An Electronically Stabilized Path will ensure that the robot will maintain its planned path to its best capability considering acceleration, drag, gravity and inertia. This feature is secured through our TrueMove.

Active Brake System controls the braking while ensuring the robot maintains its path.

To achieve optimized performance, the robot adapts to true payloads through its Self-tuning Performance. This feature is based on QuickMove.

Passive safety features

These features include options like load identification, moveable mechanical stops and double-safe position switches.

IRB 7600

Specification

Robot versions	Reach	Handling capacity	Center of gravity	Max. wrist torque
IRB 7600-500	2.55 m	500 kg	360 mm	3010 Nm
IRB 7600-400	2.55 m	400 kg	512 mm	3010 Nm
IRB 7600-340	2.8 m	340 kg	360 mm	2750 Nm
IRB 7600-325	3.1 m	325 kg	360 mm	2680 Nm
IRB 7600-150	3.5 m	150 kg	360 mm	1880 Nm
(IRB 7600-150 loaded with 100 kg)			1660 mm)	

Extra loads can be mounted on all variants

50 kg on upper arm and 550 kg on frame of axis 1.

Number of axes: 6

IRC5 controller variants: Single cabinet, Dual cabinet

Performance

Axis working range

Axis	Working range
Axis 1 Rotation	+180° to -180°
Axis 2 Arm	+80° to -60°
Axis 3 Arm	+60° to -180°
Axis 4 Wrist	+300° to -300°
Axis 5 Bend	+100° to -100°
Axis 6 Turn	+300° to -300°

Axis max speed

	325/500kg	400 kg	340 kg	150 kg
Axis 1	75°/s	75°/s	75°/s	100°/s
Axis 2	50°/s	60°/s	60°/s	60°/s
Axis 3	55°/s	60°/s	60°/s	60°/s
Axis 4	100°/s	100°/s	100°/s	100°/s
Axis 5	100°/s	100°/s	100°/s	100°/s
Axis 6	160°/s	160°/s	160°/s	190°/s

A supervision function prevents overheating in applications with intense and frequent movements.

Working range

IRB 7600-325/3.1

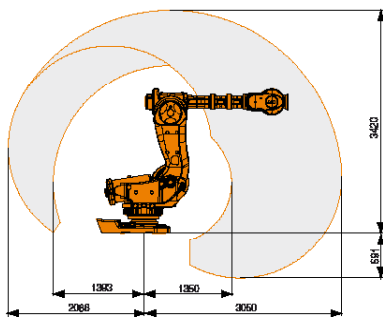

IRB 7600-400/2.55 / IRB 7600-500/2.55

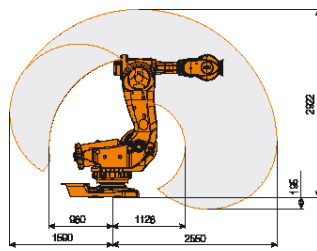

IRB 7600-340/2.8

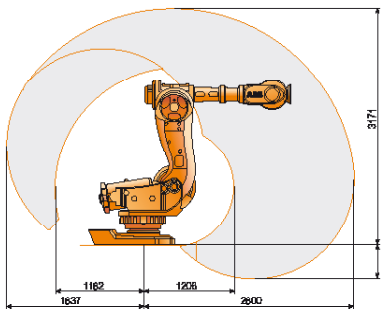

IRB 7600-150/3.5

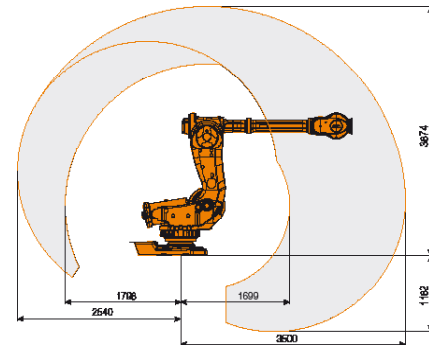

Electrical connections

Supply voltage	200-600 V, 50/60 Hz
----------------	---------------------

Physical

Dimensions robot base	1206.5 x 791 mm
Weight	2.400-2.450 kg

Environment

Ambient temperature for mechanical unit	
During operation	+5 °C (41 °F) up to +50 °C (122 °F)
During transportation & storage for short periods (max 24 h)	-25 °C (13 °F) up to +55 °C (131 °F) up to +70 °C (158 °F)
Relative humidity	Max 95%
Degree of protection	
Manipulator	IP67
Protection	Foundry Plus 2
Controller	Air cooled
Computer system	Totally enclosed
Noise level	Max 73 dB (A)
Safety	Double circuits with supervision, emergency stops and safety functions, 3-positions enable device.
Emission	EMC/EMI-shielded

Data and dimensions may be changed without notice