

# IRB 6620 Industrial Robot

Main Applications  
Machine Tending  
Material Handling  
Spot Welding



### The agile spot welder

The IRB 6620 is a flexible and agile robot with a large working envelope. The robot combines four robots in one: floor-standing, tilted or inverted mounted and shelf capability.

This compact robot opens up opportunities for new flexible and improved line concepts. Functions that all help saving floor space, creating higher robot density and shorter lines.

This relatively small and compact robot is easy to install thanks to its low weight. In spite of its small size neither the handling capacity nor the reachability are affected. Putting the robot in retracted position, making it work from below (crawler) and working on the rear side of the robot are some examples of efficient working methods resulting in a more dense and agile solution. The robot's compactness and shelf capability also make it ideally suited for applications where robots are placed on different levels. The shelf mounted robot may in this case be tilted to increase space between the two levels.

With the IRB 6620 you get a flexible and cost efficient solution that generates high uptime and lower production costs.

### Machine tending

IRB 6620 is also suited for machine tending applications such as Die Casting and Injection Molding, that requires minimised extraction time. The main benefit is the huge working range downwards making the robot ideal to mount on top of a machine working downward to save costly floor space. Another benefit in different material handling also saving floor space applications is the IRB 6620 ability to work inverted mounted. In all these configuration the installation will benefit from the very low weight of the robot.

# IRB 6620

## Specification

Reach	2.2 m	
Handling capacity	150 kg	
Extra loads can be mounted on to the robot:	50 kg on to the upper and 100 kg on to the robot base.	
Number of axes:	6	
Protection:	IP 54 IP 67 with Foundry Plus 2 option	
Mounting:	Floor, tilted or inverted	
IRC5 Controller variants	Single cabinet, Dual Cabinet	

## Performance

Position repeatability:	0.03 mm	
Axis movements	working range	Axis max speed
Axis 1 Rotation	+170° to -170°	100°/s
Axis 2 Arm	+140° to -65°	90°/s
Axis 3 Arm	+70° to -180°	90°/s
Axis 4 Wrist	+300° to -300°	150°/s
Axis 5 Bend	+130° to -130°	120°/s
Axis 6 Turn	+300° to -300°	190°/s

A supervision function prevents overheating in applications with intensive and frequent movements.

## Electrical connections

Supply voltage:	200 - 600 V, 50/60 Hz
-----------------	-----------------------

## Physical

Dimensions robot base:	1007 x 760 mm
Weight:	900 kg

## Environment

Ambient temperature for mechanical unit:	
During operation	+5°C (41°F) to +50°C (122°F)
During transportation and storage	-25°C (13°F) to +55°C (131°F)
For short periods (max 24 h) up to	+70°C (158°F)
Relative humidity	Max 95%
Safety	Double circuits with supervisions, emergency stops and safety functions. 3-position enable device.

UL approved	
Emission	EMC/EMI shielded
Option	Foundry Plus

## Environment

- Designed for dress packs
  - Rigid design with collision resistance
  - Prolonged wrist with smooth surfaces for dress pack life time
  - Large centre hole for welding cables in the foot
  - Easy change of dress pack
  - Weld spatter protection on gear sealing
  - 50 kg load capacity on rear upper arm for dress pack
  - Insulated tool flange available
- Data and dimensions may be changed without notice

## Working range

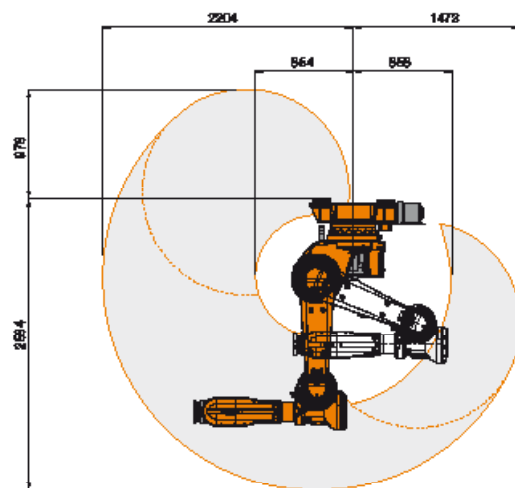
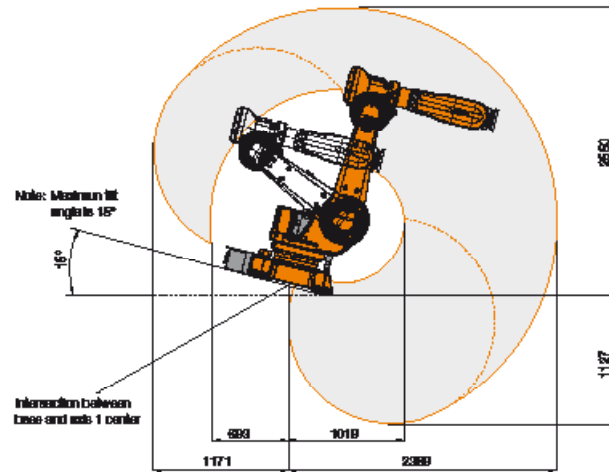
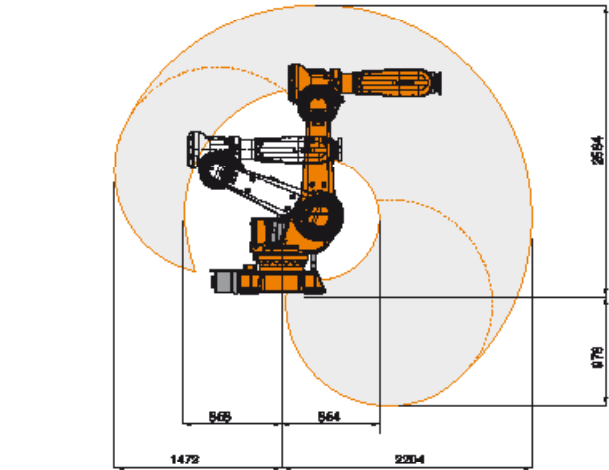

© Copyright ABB Robotics. PR10333 EN\_R8 May 2010.