

IRBP C Positioner

The ABB positioners are optimized to be used for manipulating of work pieces in arc welding, thermal cutting and other applications. All axes can be fully coordinated with the robot when programming as well as during operation.



IRBP C

This positioner features a twin station solution where the robot works on one side and the operator loads and unloads on the other side. The workpiece is fixed and cannot be manipulated during the process. A screen is fitted between the two stations, which protects the operator from arc-eye.

The positioner IRBP C, which comes in two variants, is designed to handle workpieces including fixture of a weight up to 1000 kg.

The modular design, few and heavy-duty moving parts as well as minimal maintenance demands make the positioner service friendly.

Dynamically adaptive software plus high speed drives result in fast changeovers and high productivity.

General IRBP features

All ABB positioners offer users a complete and efficient solution. They are of a robust design to ensure excellent stability and are well protected for operation in harsh production environments. All positioners can be combined with any ABB six axes robots except the small IRB 120.

The positioners are easy to use with clear, simple instructions for programming. The control equipment is located in the robot controller and uses the same drive system and software as the robots.

ABB's positioners are designed to be highly functional yet compact to make maximum use of available floor space. Standardised dimensions for all rotating plates greatly simplify the exchange of fixtures.

Dynamic modelling allows rapid acceleration, fast movements and re-orientation so that cycle times are kept to a minimum. The dynamic model automatically compensates for the effects of gravity, inertia and friction to provide fast movements (QuickMove™) and accurate following of the programmed path (TrueMove™).

The Load ID-function is used to calculate the centre of gravity and the inertia of the workpiece and of the fixture.

To meet requirements from our users the positioners can be supplied, or retrofitted, with a comprehensive range of pneumatic swivels (1 and 2 channels) and slip-rings (10 power signals and Profibus).

ABB positioner systems can be supplied with all necessary safety equipment.

IRBP C

Specification

Variants		C-500	C-1000
Handling capacity/side	kg	500	1000
Max load diff. sides 1 and 2	kg	350	500
Index time	s	3.3 - 3.8	3.5 - 3.7
Weld to weld time	s	5.1 - 5.6	5.8 - 6.0
Repetitive accuracy (r=500)	mm	+/-0.05	+/-0.05

Measurements

	A	B	C
C-500	800	1850	2450
C-1000	900	1950	2930

For complementary information, please see the product specification.
ABB reserves the right to change data without notice.

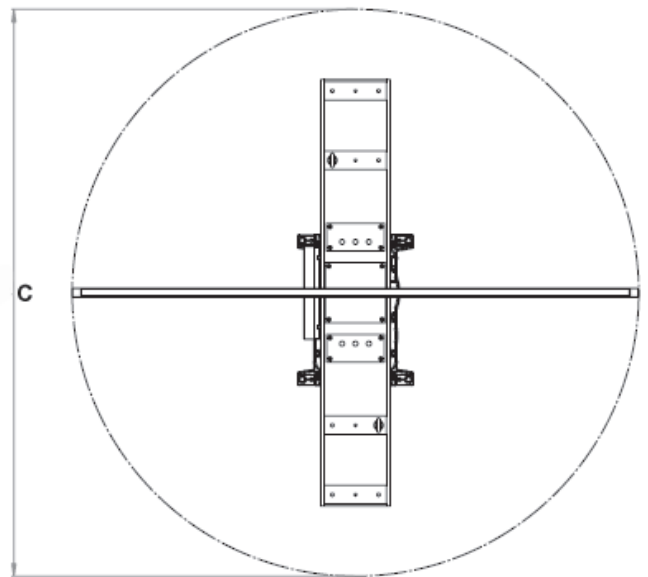
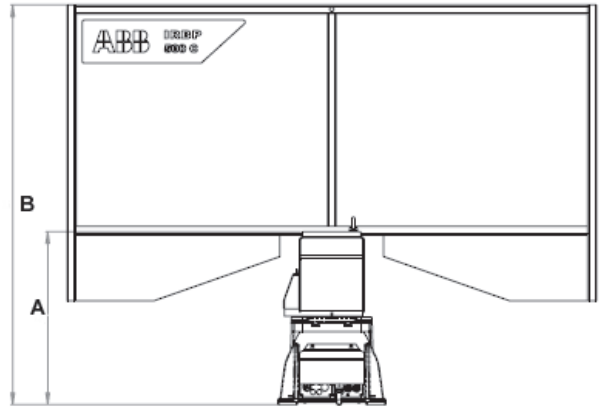

Copyright © ABB Robotics PR110113EN_R4 April 2010