

6.16 Proximity Switch Mount

Weight.....See Part No.
 Material.....Aluminum

Part No.	A	Weight
9934076	Ø30.5 mm	60 g
9934077	Ø18.5 mm	80 g
9934078	Ø12.5 mm	90 g

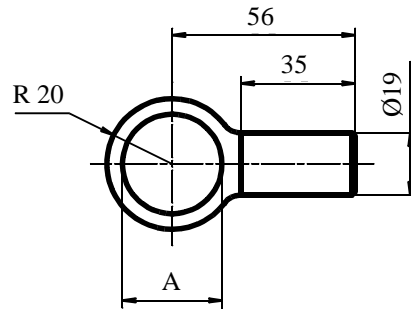
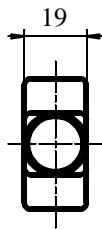
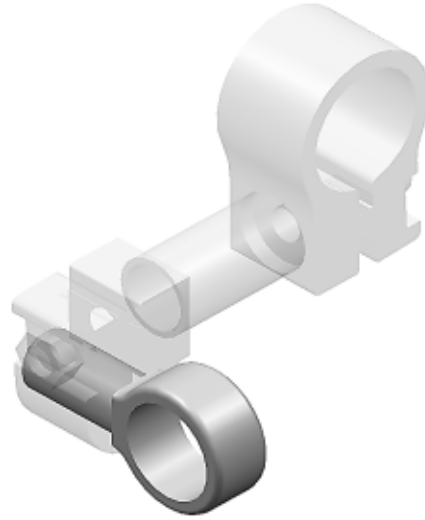

Filename: Kap6.fm, Mod date: 2005 04 07

6.19 Support Anglemount

<p>Only for PS2 shuttler</p> <p>Type: Cross Boom Adaptor Part number: 9937892 Drawn</p> <p>Part number: 9937893, Symmetrical Opposite</p> <p>Weight: 514 g. Material: Aluminum Torque A: 248 Nm Torque B: 248 Nm Tightening torque: 47 Nm</p>		
<p>Type: Support Anglemount Part number: 9938198 Weight: 385 g. Material: Aluminum Torque M10: 47 Nm Torque A for Ø38 tube: 300 Nm Torque B for Ø38 tube: 300 Nm</p>		<p>For attaching two Ø38 tubes at 90° angle</p>

Filename: Kap6.fm, Mod date: 2005 04 07

<p>Only sold as spare part</p> <p>Type: Angle Mount 90°</p> <p>Part number: 39915121</p> <p>Weight: 468 g</p> <p>Material: Aluminum</p> <p>Torque M10: 47 Nm</p> <p>Torque A for Ø38 tube: 112 Nm</p> <p>Torque B for Ø38 tube: 160 Nm</p>		
<p>Type: Angle Mount 90° (Split)</p> <p>Part number: 39915122</p> <p>Weight: 568 g</p> <p>Material: Aluminum</p> <p>Torque M10: 47 Nm</p> <p>Torque A for Ø38 tube: 100 Nm</p> <p>Torque B for Ø38 tube: 168 Nm</p>		

Filename: Kap6.fm, Mod date: 2005 04 07

6.23 Gripper Mount for type B

(Only sold as spare part)

Part No. 9938390

Weight..... 1430 g

Material Aluminum

Tightening torque for M10..... 47 Nm

Tightening torque for M8..... 24 Nm

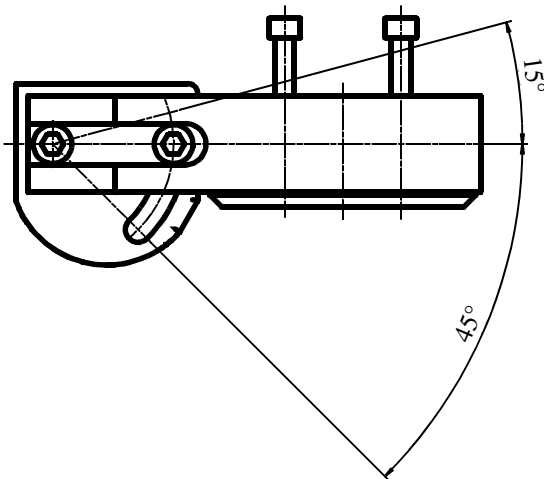
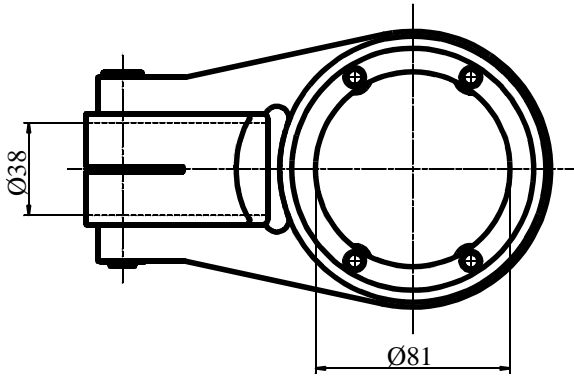
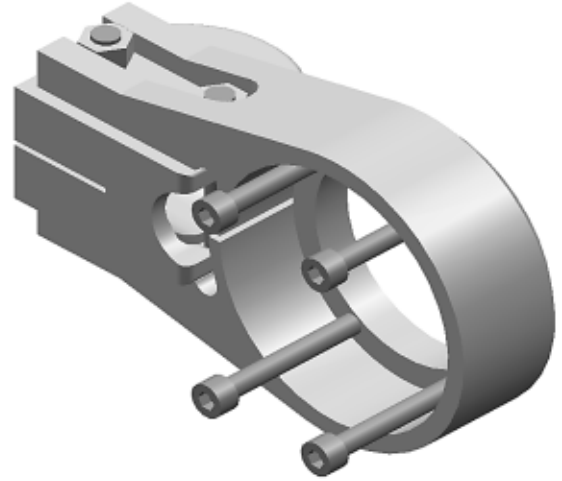

6.26 Gripper Mount for type A

Part No. 91697130

Weight: 244 g

Max Torque A 352 Nm

Max Torque B 50 Nm

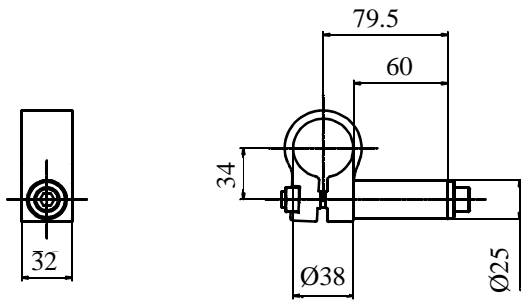
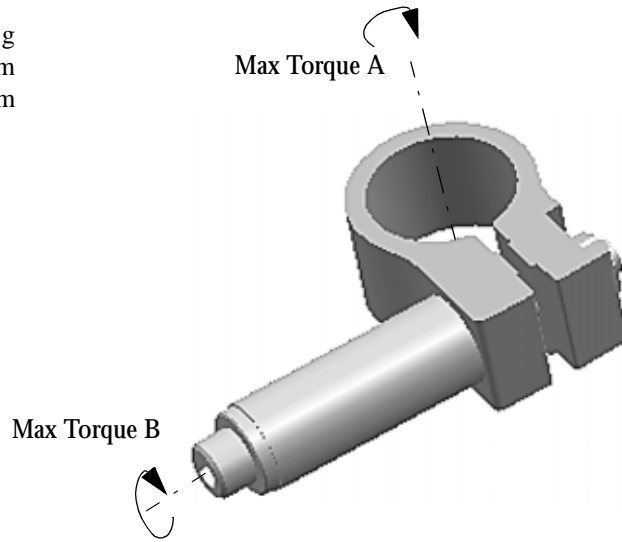

6.28 Anglemount Ø76 mm

Part No. 91109563

Weight..... 1700 g

Material.....Aluminum

Tightening Torque for M10 47 Nm

Maximum Torque A for Ø76..... 800 Nm

Maximum Torque B for Ø66..... 800 Nm

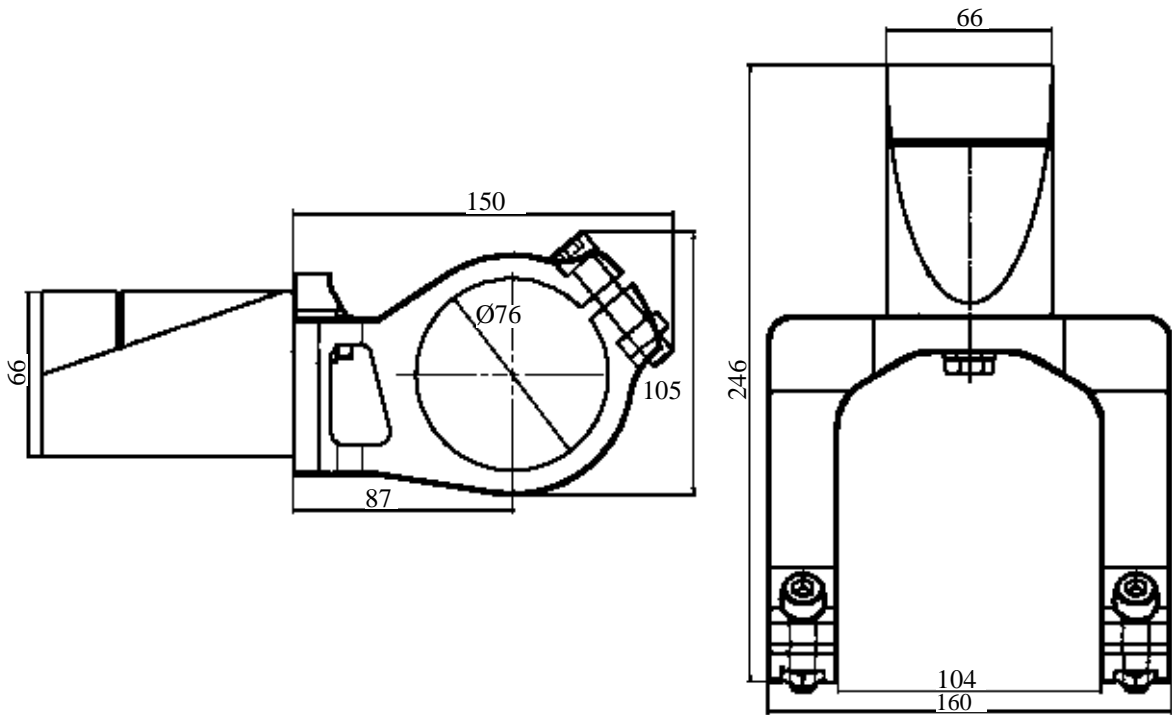
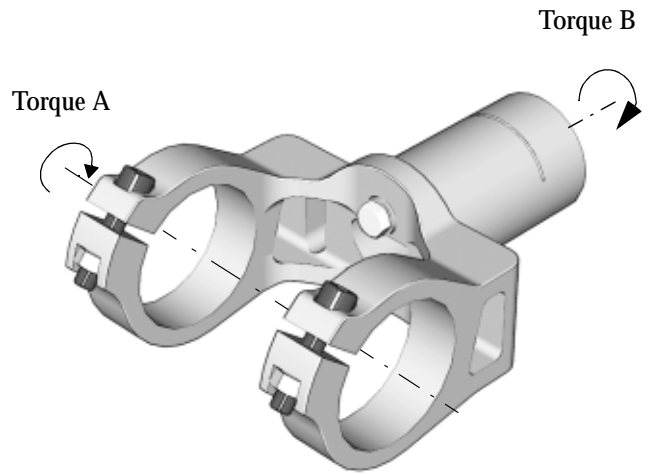

6.33 Angle mounts

<p>Type: Angle mount 90° Ø38/Ø38</p> <p>Part number: 91109687</p> <p>Weight: 480 g</p> <p>Material: Aluminum</p> <p>Torque M10: 47 Nm</p> <p>Max torque A for Ø38: 160 Nm</p> <p>Max torque B for Ø38: 110 Nm</p>		
<p>Type: Angle mount swivel type Ø38/Ø38</p> <p>Part number: 91110335</p> <p>Weight: 350 g</p> <p>Material: Aluminum</p> <p>Torque M10: 47 Nm</p> <p>Max torque A for Ø38: 352 Nm</p> <p>Max torque B for Ø38: 352 Nm</p> <p>Max torque C: 50 Nm</p>		

Filename: Kap6.fm, Mod date: 2005 04 07