

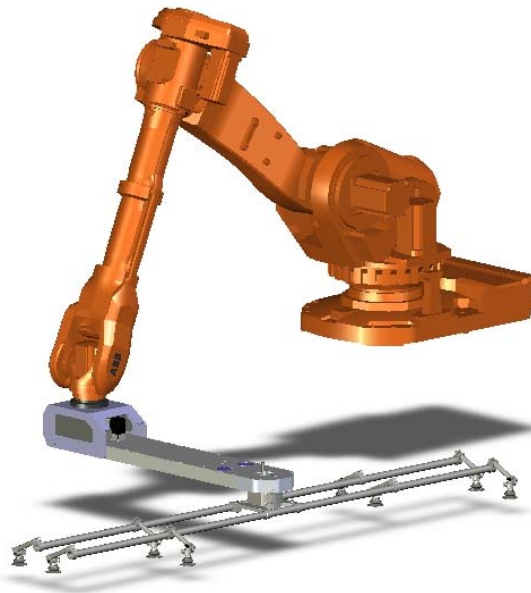

7th axis

Robot Peripherals



Extend your robot's horizon

Because we're driven by our customers' needs, we develop technologies to give you reliability and fast working cycles. An external axis added to the robot is one of the parts of the puzzle. The ABB 7th axis is an additional external axis integrated to the robot wrist which transports the part from press to press maintaining the orientation of the part and following the optimal, natural path. The interpress distance can be considerably reduced and production output increased.

Unlike most existing products, the ABB external axis does not consist of a simple translation from the 6th axis of the robot, but a real co-ordinated additional axis which maximizes your robot versatility at minimum cost.

When it comes to the operator and handling simplicity, the ABB 7th axis delivers greater programmable freedom. All movements are programmed from the robot teach pendant, ensuring smooth, simple operation.

ABB 7th axis is designed to assure the reliable and effective utilization of a robot's capacity, to maximize the value of your automation investment. Its robust design offers excellent operating reliability, long life, and high automation precision. The ABB motor unit is used for this specific peripheral equipment

because of the need of servo operated motors that are absolutely synchronized with the movements of the robot.

We provide you with solutions, helping you to increase production.

By means of the 7th axis, you could achieve a substantial and quantifiable increase in your throughput. Improved cycle times are demonstrable by either our lab tests or by real project measures. However, in the race to stay ahead, we never compromise on safety. Extensive checks including deflection, accuracy, repeatability and belt stabilisation are performed.

Adding the 7th axis to your robot also brings advantages to the tooling. No central boom is needed anymore, so only end-of-tool is replaced when preparing new production.

For customers who want to change automated production as fast as possible, the 7th axis performs equally or better than conventional tooling systems with central booms. Tool changing can be handled automatically by the robot within the working area.

Just as you can rely totally on our robots, you can rely totally on the new ABB 7th axis.

7th axis

Robot Peripherals

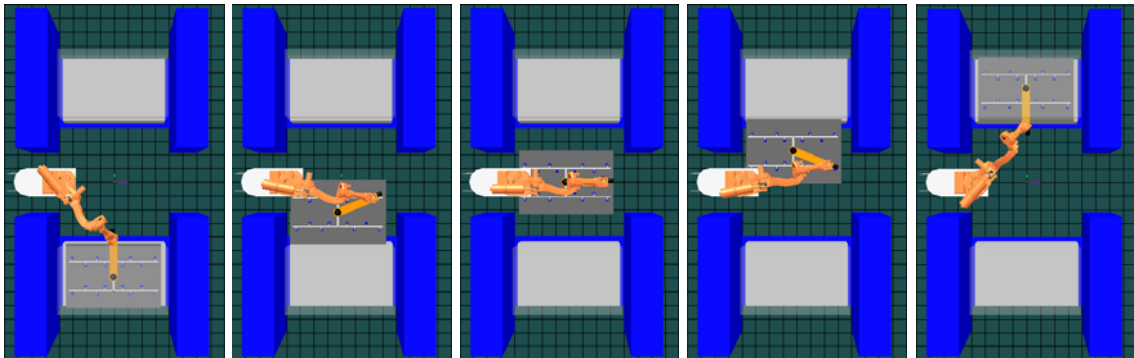

The Process

Thanks to our 7th axis, the robot keeps the orientation of the part when transferring the part from one press to the other. Obviously, this entails important reductions in both the inside-press times and also in the inside-press overlapping between loading and unloading robots.

Increases in production rates are the result of both the effect of maintaining the orientation of the part and also from the reduction in the interpress distance, besides the obvious advantages in reducing floor space in the workshop.

In addition to this, because you do not rotate the part in the interpress movement you find less work piece inertia and consequently less vibration problems.

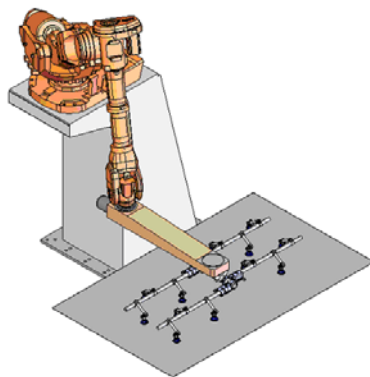

Technical Data

Total length (mm)	1640
Center to Center length (mm)	1300
Width (mm)	255
Base depth (mm)	220
Extension depth (mm)	70

Weight (Kg)	35
Material	Aluminium

Motor unit for external axis	ABB
------------------------------	-----

Quick-Change for end tooling	Master-Tool plate type enabled
Electrical signals passage	enabled
Pneumatic supply	enabled

