

6.9 Central Boom Spacer, 130 and 200 mm

Type: Central Boom Spacer L=130
 Part No. 9934876
 Weight..... 824 g
 Material..... Aluminum
 Tightening Torque for M10 47 Nm
 Maximum Torque for Ø76 Tube 440 Nm

Type:..... Central Boom Spacer L=200
 Part No..... 9934877
 Weight 1158 g
 Material Aluminum
 Tightening Torque for M10..... 47 Nm
 Maximum Torque for Ø76 Tube 440 Nm

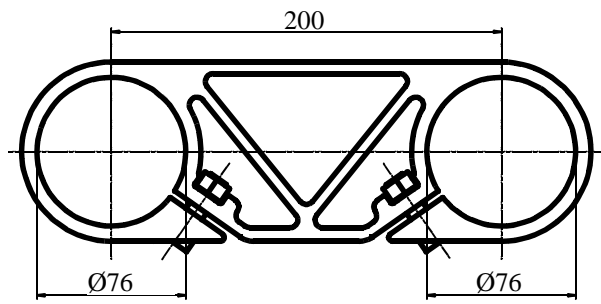
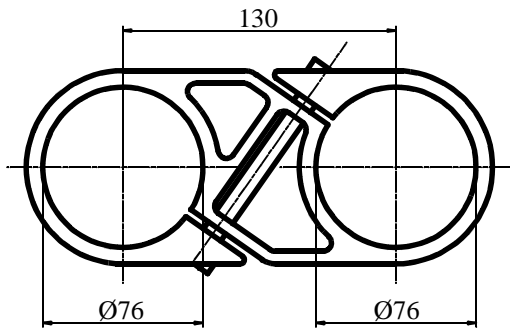
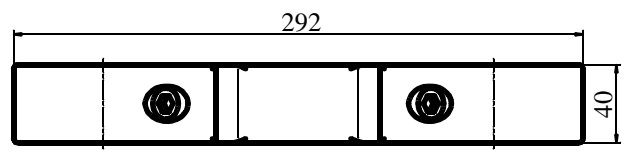
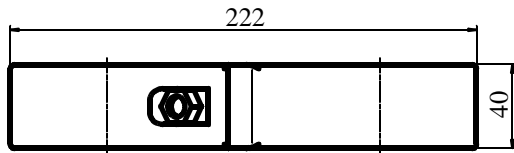
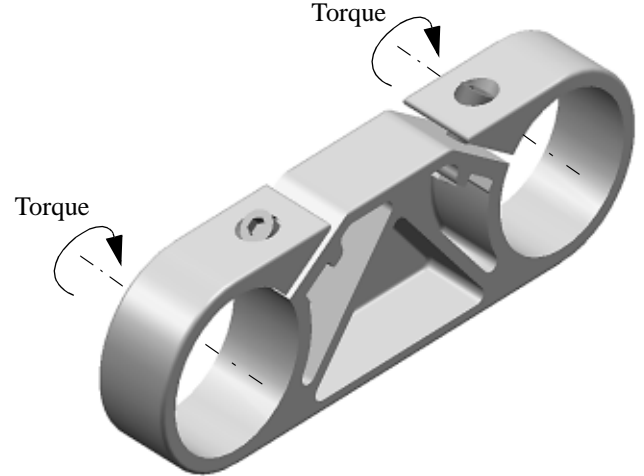
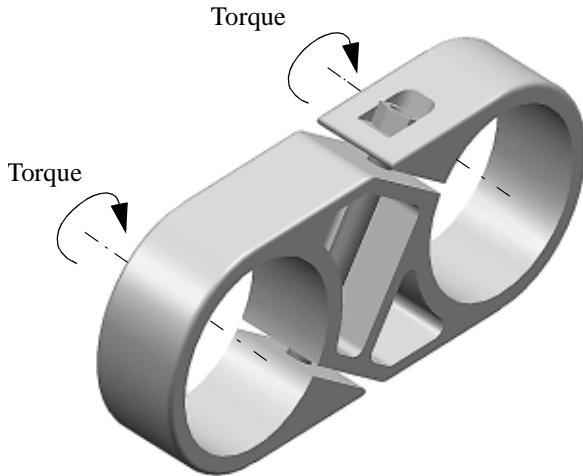

Filename: Kap6.fm, Mod date: 2005 04 07

6.10 Central Boom Spacer, 250 and 300 mm

Type:Central Boom Spacer L=250
 Part No. 9934878
 Weight..... 1310 g
 MaterialAluminum
 Tightening Torque for M10 47 Nm
 Maximum Torque for Ø76 Tube 440 Nm

Type:..... Central Boom Spacer L=300
 Part No..... 9934879
 Weight 1464 g
 Material Aluminum
 Tightening Torque for M10..... 47 Nm
 Maximum Torque for Ø76 Tube 440 Nm

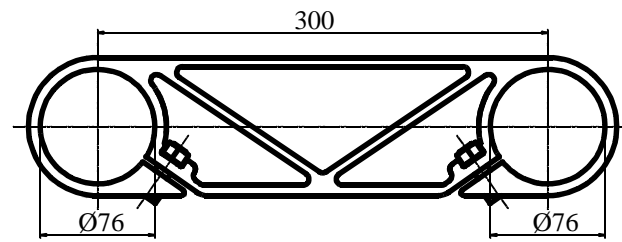
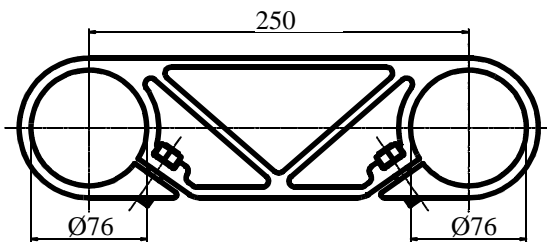
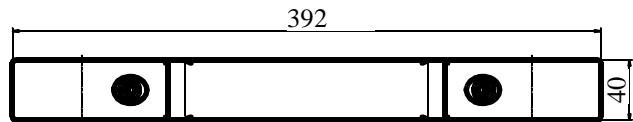
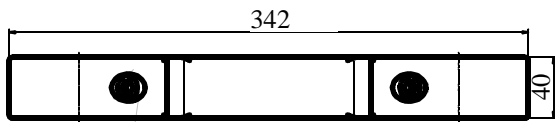
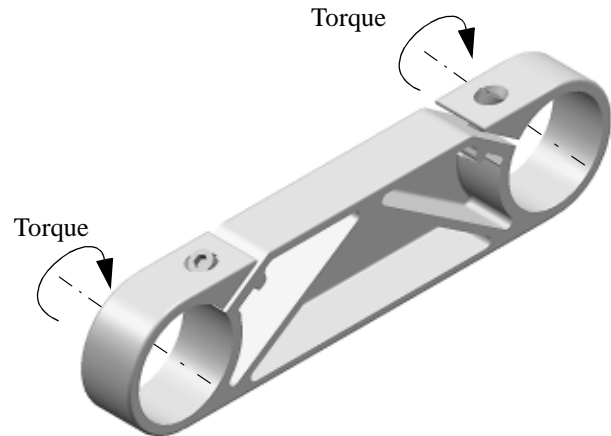
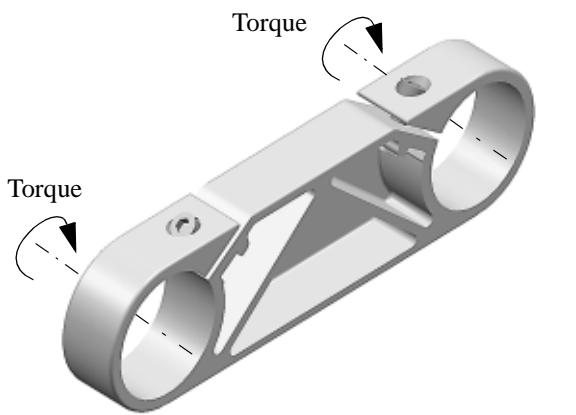

Filename: Kap6.fm, Mod date: 2005 04 07