

PalletPack 460 Function package

PalletPack 460 is a package of pre-engineered products designed to make robotic end-of-line and bag palletizing solutions more accessible and easier to use.



Easy way into automation

ABB's PalletPack 460 is a package of pre-engineered products configured for end-of-line palletizing that greatly improves ease of use for integrators and lowers the hurdle to entry into automation. The function package, available for either high-speed bag palletizing or compact end-of-line case palletizing, consists of the IRB 460 palletizing robot, a FlexGripper (either the Claw or one-zone Clamp gripper), an ABB PLC, a Jokab Safety PLC, support software, user documentation and a FlexPendant that features a graphical HMI.

The world's fastest palletizing robot - the centerpiece

The IRB 460 robot is a 4-axis robot that is the fastest of its kind. With a reach of 2.4 meters and 110-kilogram capacity, this compact robot's small footprint makes it ideal for integration into existing packing lines.

Wizard enabled set-up and programming

A true value provider in the PalletPack 460 is the program wizard. The wizard enables PLC programmers to program the robots, so you do not need to learn robot programming to install a robot cell, and you don't get any of the complications that can arise when special skills are required. Instead the wizard makes it similar or the same as PLC programming.

Cost-efficient and easily integrated

This function package offers pre-engineered, integrated hardware with full documentation, lowering the integration cost and significantly reduces engineering time since there is no need to prepare additional documentation and drawings. The PalletPack 460 comes with all documentation as standard and the wizard makes creating new programs really easy. All set-up, programming and operation are done via the standard ABB Robotics HMI, The FlexPendant. This features a graphical interface with four user-friendly screens: pallet and pick set-up, pallet pattern set-up, path profile edition and movement edition.

The PalletPack 460 ensures that robotic palletizing solutions are cost effective and easy to integrate, program and use.

Unrivalled experience and global support

With more than 25 years of experience in the palletizing sector, ABB is a multinational corporation that has a sales and service organization in 53 countries and over 100 locations.

Technical specifications

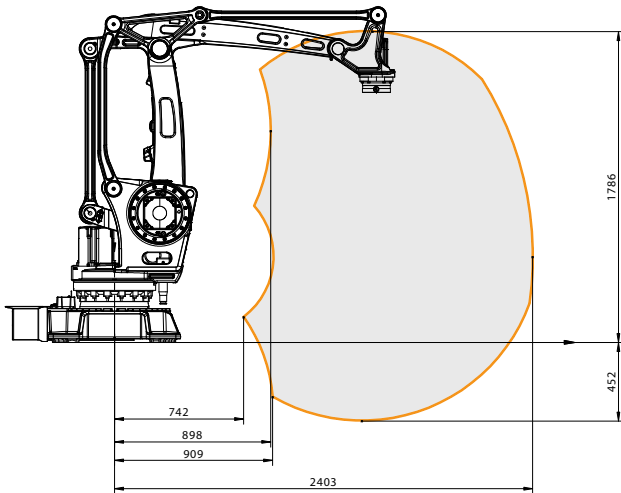

IRB 460

Handling capacity	110 kg
Reach	2.40 m
Number of axes	4
Protection	IP67
Mounting	Floor
IRC5 controller variants	Single cabinet
Integrated power signal supply	Optional
Integrated air supply	Optional

Physical

Dimensions robot base	1007 x 720 mm
Robot weight	925 kg

Performance (according to ISO 9283)

Position repeatability (RP)	0.20 mm
Path repeatability (RT)	0.11 mm

PalletWare Wizard

Main functionality

- Create and adjust jobs.
- Train robot movements.
- Create and adjust pallet patterns.
- Control palletizing cell devices.
- Control and supervise cell safeties and faults.
- Request robot commands.
- Handle production changeover.
- Pick up items, pallets and slip sheets and place them according to predefined patterns.

Requirements

The PalletWare software is delivered on a CD, which contains all the software needed to install PalletWare as also the necessary documentation. PalletWare only supports the IRC5 robot controller. The RobotWare software is preinstalled on the robot controller and is also supplied on a CD with the controller.

Required RobotWare options:

- FlexPendant Interface
- Profibus Fieldbus Adapter or ProfiNet Fieldbus Adapter

Data and dimensions may be changed without notice



FlexGripper - Claw

Handled products	1
Max. weight per lift	50 kg
Gripper weight	60 kg
Finger pitch	80 mm
Bag height range	120 - 250 mm
Bag length range	300 - 750 mm
Bag width range	250 - 450 mm
Cable rotation range	+ - 180°
Air pressure	4-6 bar

FlexGripper - Clamp 1-zone

Handled products	1-2
Max. weight per lift	40 kg
Gripper weight	45 kg
Case height range	150 - 330 mm
Case length range	200 - 650 mm
Case width range	200 - 500 mm
Cable rotation range	+ - 180°
Air pressure	4-6 bar

