

6.24 Gripper ISI for type B (180°)

(Only sold as spare part)

Part No. 3046776

Weight..... 1800 g

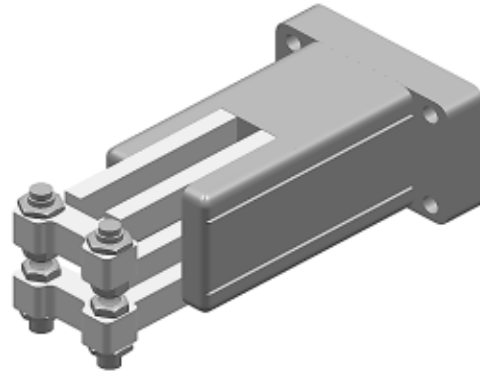
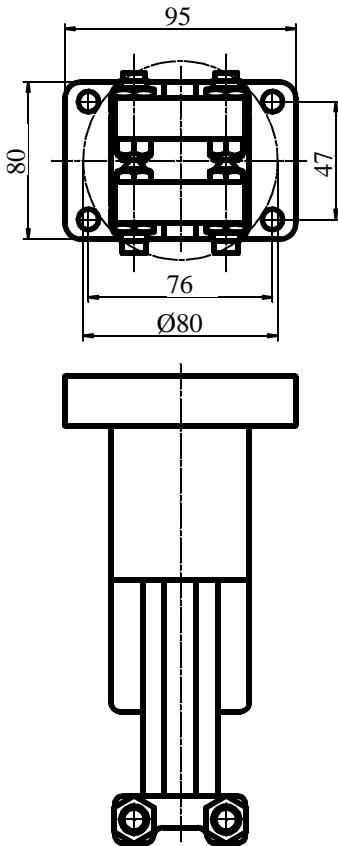

Filename: Kap6.fm, Mod date: 2005 04 07

6.25 Gripper type A

Part No.91204027

Weight:.....2000 g

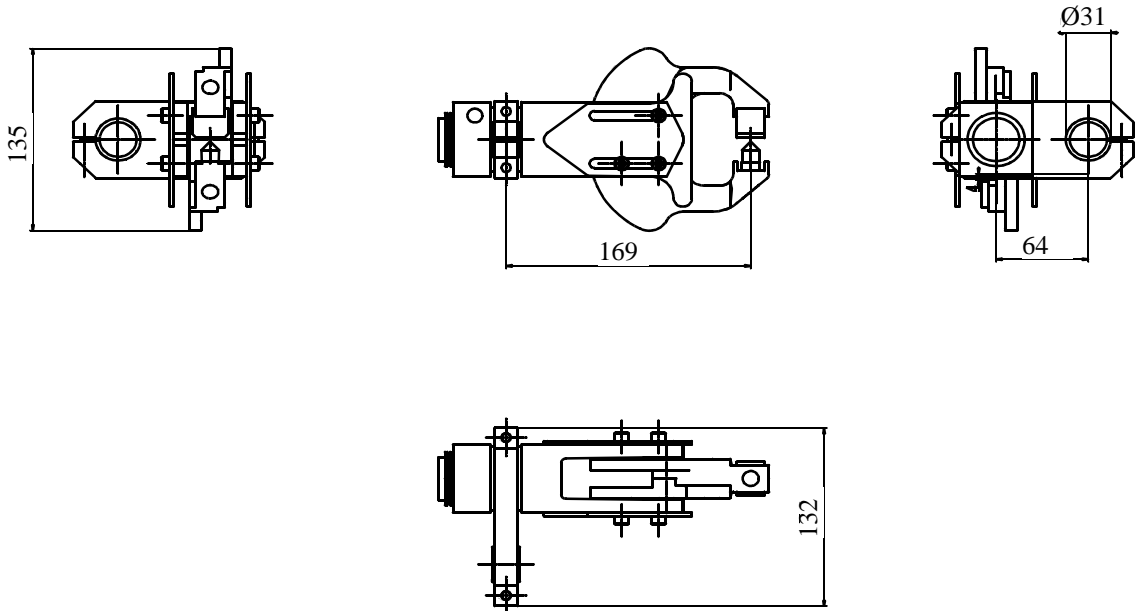
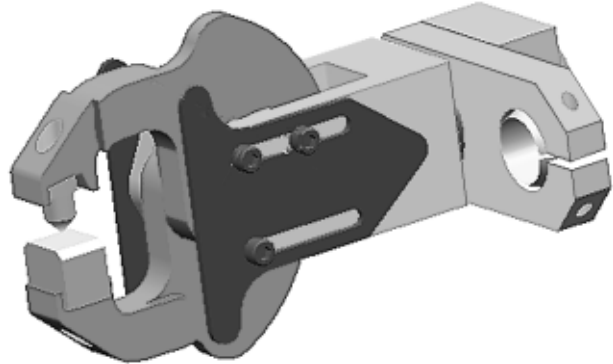

Filename: Kap6.fm, Mod date: 2005 04 07

6.26 Gripper Mount for type A

Part No. 91697130

Weight: 244 g

Max Torque A 352 Nm

Max Torque B 50 Nm

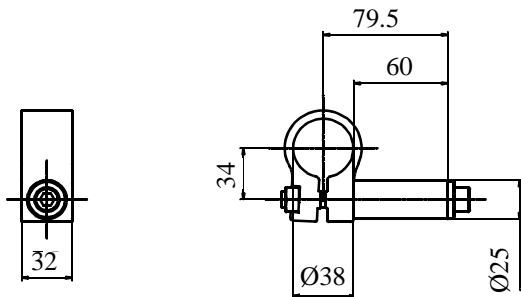
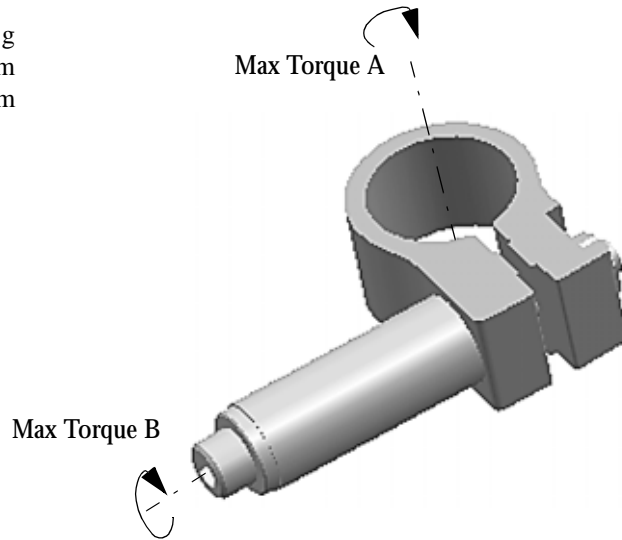

Filename: Kap6.fm, Mod date: 2005 04 07