

6.14 Swivel Arm

Length & Weight See Part No.
 Material Aluminum
 Tightening Torque for M10 47 Nm
 Maximum Torque A for Ø38 tube 352 Nm
 Maximum Torque B for Ø25 tube 48 Nm
 Maximum Torque C for Ø19 tube 120 Nm

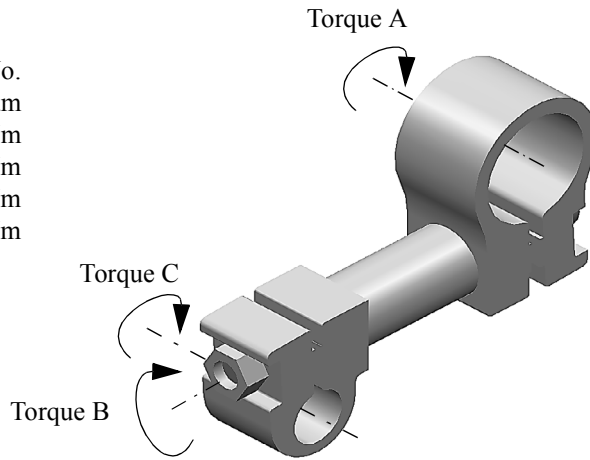

Swivel Arm

Part No.	Length	Weight
9934860	85 mm	312 g
9934861	125 mm	354 g
9934862	165 mm	390 g
9934863	205 mm	436 g

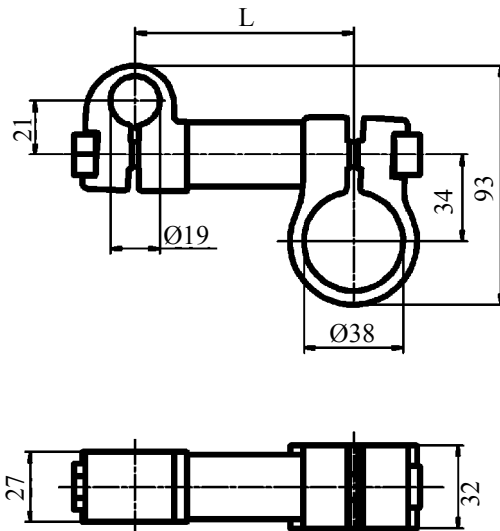

Option

Suction cup attachments are not included with the Swivel Arm.

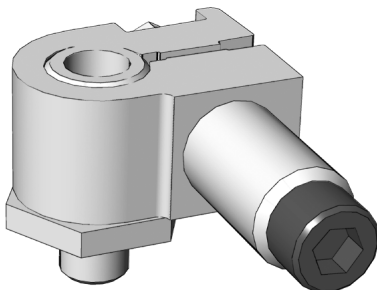

See 6.18 Suction Cup Attachment
 pages 48 - 49.

Filename: Kap6.fm, Mod date: 2005 04 14

6.15 Swivel Arm

Length & Weight See Part No.
 Material Aluminum
 Tightening Torque for M10 47 Nm
 Maximum Torque A for Ø38 tube 352 Nm
 Maximum Torque B 40 Nm
 Maximum Torque C for Ø19 tube 40 Nm

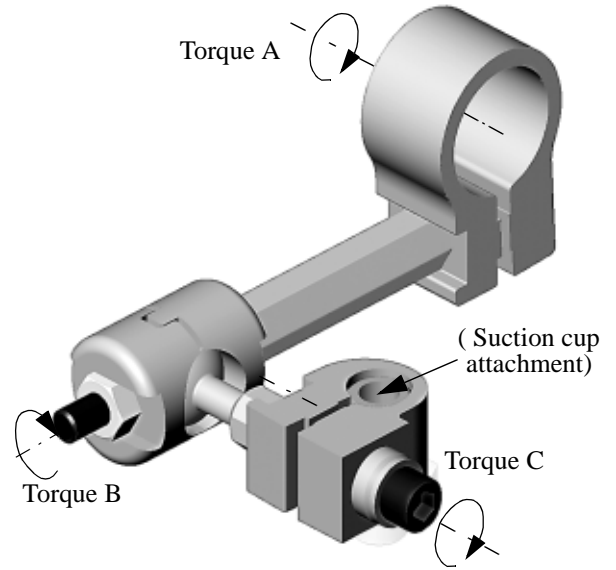

Swivel Arm

Part No.	L=Length	Weight
91110800	85 mm	557 g
91110801	125 mm	598 g
91110802	165 mm	639 g
91110803	205 mm	680 g

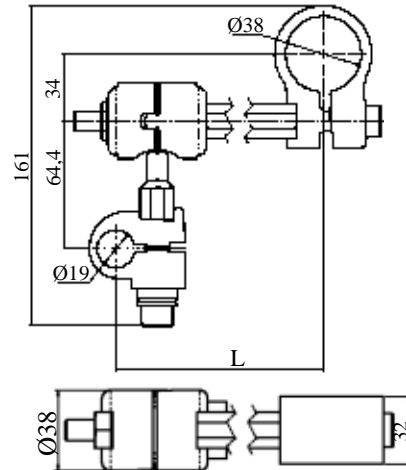

Option

Suction cup attachments are not included with the Swivel Arm.

Part No.	9937111		9939387		91108683		91108684	
	Suction cup	Air connect.	Suction cup	Air connect.	Suction cup	Air connect.	Suction cup	Air connect.
Thread type	Female	Female	Female	Female	Male	Female	Male	Female
Thread	G 3/8"	G 1/4"	G 1/4"	G 1/4"	G 1/4"	G 1/4"	G 3/8"	G 1/4"
Weight	46 g		82 g		76 g		84 g	
Material	Steel		Steel		Steel		Steel	