

# FlexArc® 250K MultiMove™ Cell

Global Arc Welding Production Solution

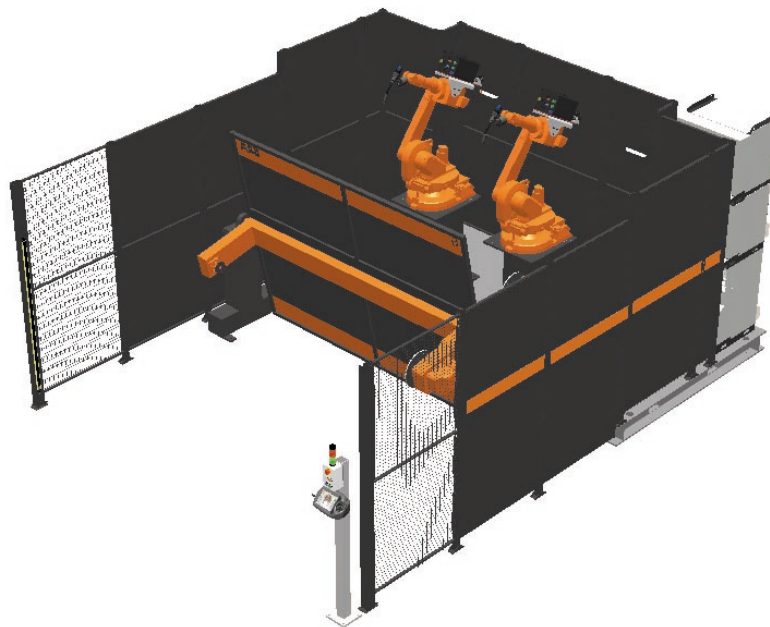

## A complete range of fully integrated, standardized welding cells

*FlexArc robotic welding cells are complete robot systems available in several flexible and versatile, standard modular packages. The cells are delivered ready to weld.*

### **Flexibility**

If new parts are modified, added or specifications change, fixtures can be changed or modified on one station or both. The robot can either weld new or different parts and maintain maximum flexibility of the cell.

Each of ABB's FlexArc Cells are available in virtual format as identical replicas of the actual in Robot-

Studio and can be programmed offline on a personal computer.

Based on our marginal production solutions ABB has standard versions to meet your needs.

### **Reusability**

FlexArc cells have produced millions of parts since their introduction and are industry accepted and proven solutions.

### **High Productivity**

FlexArc cells are standard, pre-engineered solutions designed to permit quick, efficient set-up so you are running production in minutes instead of days.

# FlexArc® 250K MultiMove™ Cell

## Global Arc Welding Production Solution

### TECHNICAL DATA

#### THE 250K CELL FEATURES

Two IRB 1600 or IRB 2400L robots integrated with the IRBP 250K servo positioner  
 250K servo positioner  
 Perimeter guarding which complies with ANSI/RIA 15.06/1999  
 Man/Machine (HMI) Interface  
 Welding power supply  
 Robotic welding torch (air cooled or water cooled)  
 Robotic torch cleaner/dresser  
 Metal mounting base (transportable with fork lift pockets)  
 Operator present sensing device  
 Cables are completely integrated into the base of the cell  
 Cell door interlock device

#### IRBP

#### 250K

Handling capacity	kg	200
Cont. torque	Nm	350
Max inertia	kgm <sup>2</sup>	40
Max bending torque	Nm	650
Max speed	rpm	30
Min interchange time	s	3.2
Max interchange time	s	3.9
Repeatability (r=500)	mm	0.1
Max load diff ø 1000 mm	kg	140
Max load diff ø 1200 mm	kg	120
Optional Equipment	Torch Service Center Incl. BullsEye™, SmarTac™, Fume Hood (incl. lighting), Offline Programming Software, Virtual FlexArc™	

#### 250K SERVO POSITIONER

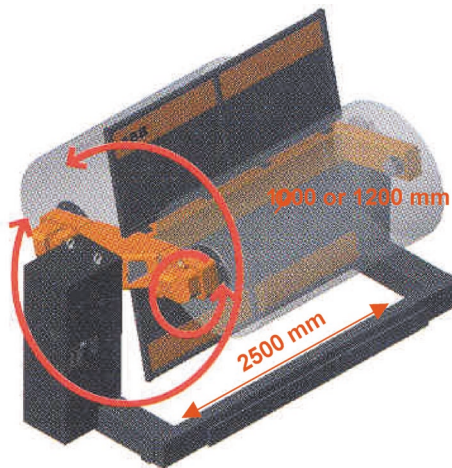

#### 250K CELL LAYOUT

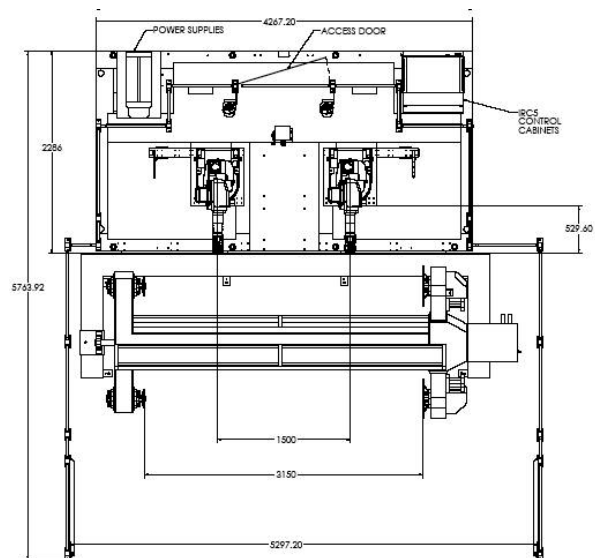

#### TYPICAL PRODUCTION CYCLE DESCRIPTION

Operator unloads and loads one fixture while the robot welds on the second fixture. When both the operator and robots have completed their operations, the positioner indexes and the cycle starts again.