



Dillion Liu, Product Manager, FlexGripper

# FlexGripper - palletizing grippers

## Clamp, Claw, Vacuum

# A range of four palletizing grippers Optimized for ABB Palletizing Robots

Claw for IRB 460 / IRB 660



Vacuum for IRB 460 / IRB 660



1 Zone Clamp for IRB 460



2 Zone Clamp for IRB 660



# FlexGripper

## Scope of supply



- **FlexGripper – Claw / Clamp / Vacuum**
- **Robot Mounting Plate**
- **Dress Pack**
- **Graphical User Interface**
- **Product and user manual**
- **Air filter (option)**

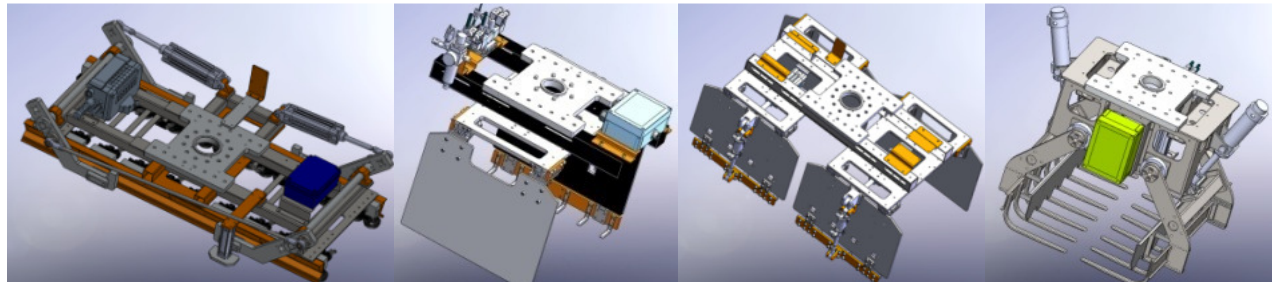

# FlexGripper Scope of supply Graphical User Interface (GUI)

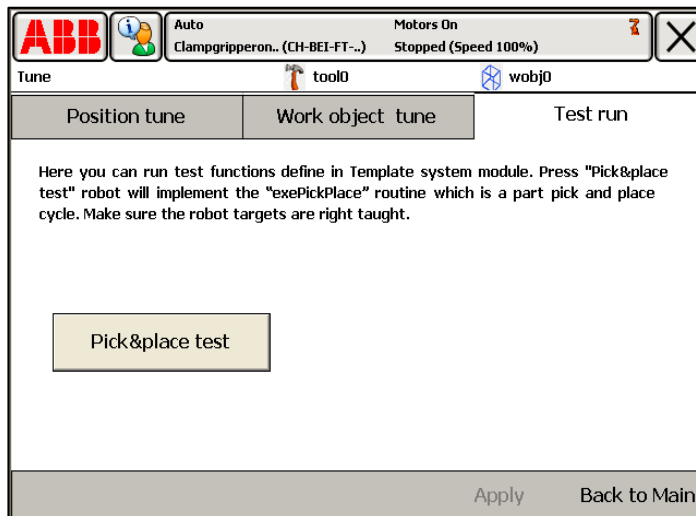
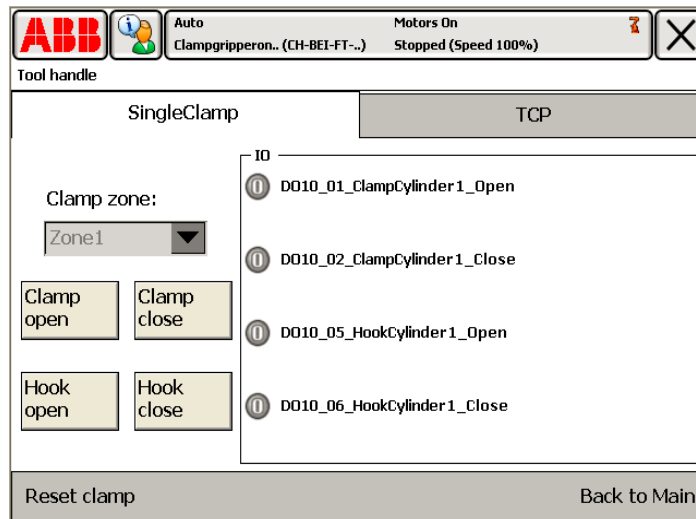

## Installation & Commission

- 4 types of gripper open close test
- One click for gripper pick & place test
- Graphical user interface to tune robot targets and work objects

## Programming

- Inputs/Outputs automatically configured
- RAPID module with gripper functions

## Production

- Monitoring of all signal and production parameters

# FlexGripper

## Scope of supply



The FlexGripper is ready to plug-and-produce on your chosen robot model

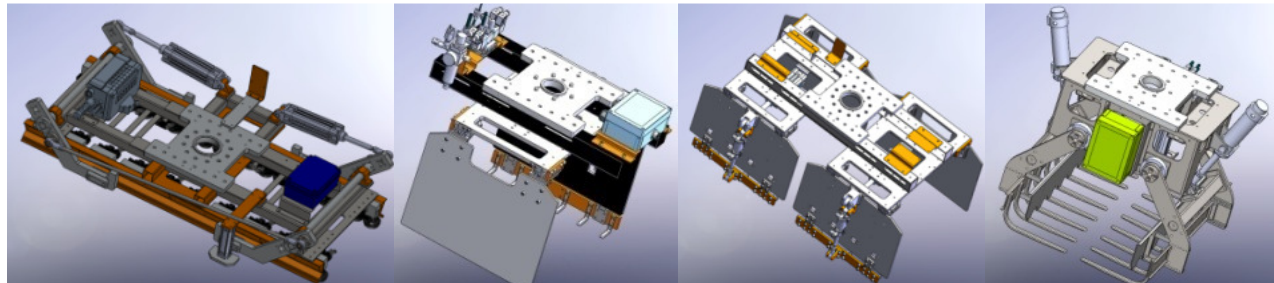



Dillion Liu, Product Manager, FlexGripper

# FlexGripper - Claw

# FlexGripper – Claw

## Key features

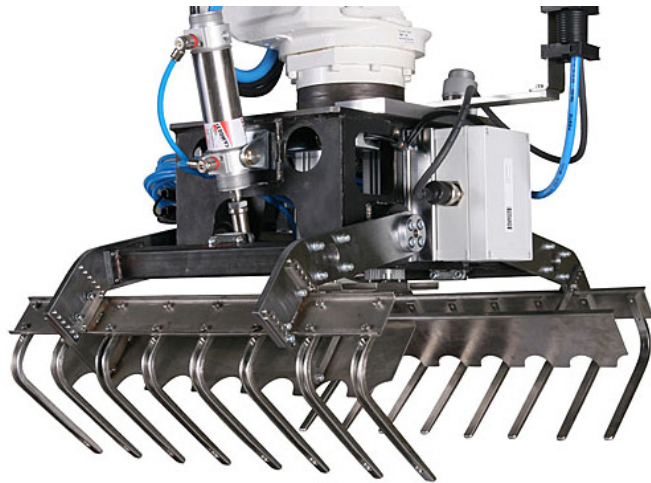

- For heavy duty bag palletizing up to 50 kg
- Pneumatically actuated mechanism to clamp the bag from sides
- Bag centering plates provided with 200 mm adjusting stroke for different bag size
- Clamp pads provided that contact the top of the bag to hold it in position
- Stroke of clamp pads :130mm
- It has replaceable stainless steel fingers

# FlexGripper – Claw

## Well adapted to the harshest condition



- **Hard coated for protection in extreme environments**
- **All bag contacting parts made by stainless steel**
- **For heavy duty bag palletizing up to 50 kg**
- **Varying bag shapes and contents**
- **Suitable for use in a wide range of industries.**

# FlexGripper - Claw

## Key data

Specification	
Handled product	1
Max. weight/lift	50 kg
Gripper weight	60 kg
Finger interval	80 mm
Bag height range	120 – 250 mm
Bag length range	300 – 750 mm
Bag width range	250 – 450 mm
Cable rotation range	+180 °
Air pressure (bar)	4-6 bar

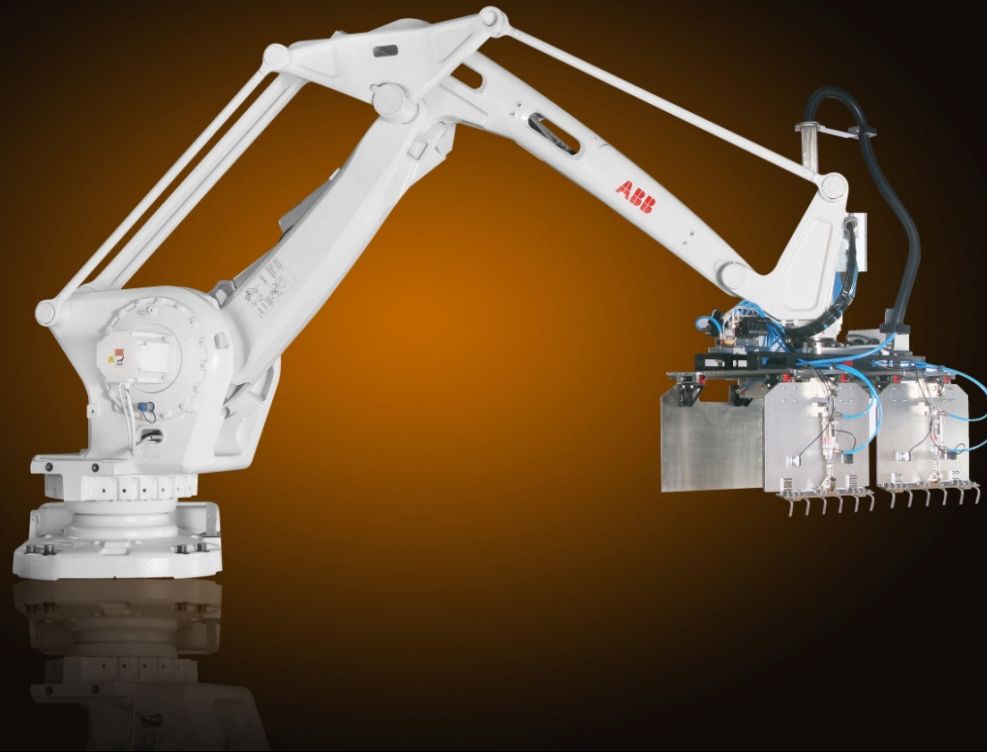

Dillion Liu, Product Manager, FlexGripper

# FlexGripper - Clamp

# FlexGripper – Clamp

Available in two versions

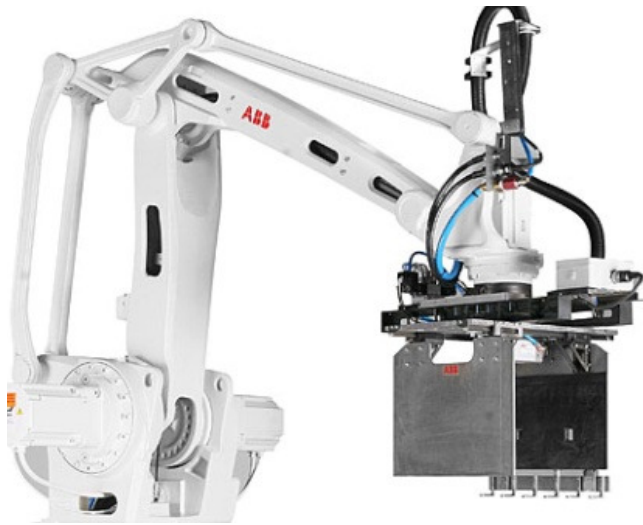

**Single Zone Version**  
Weight 45kg

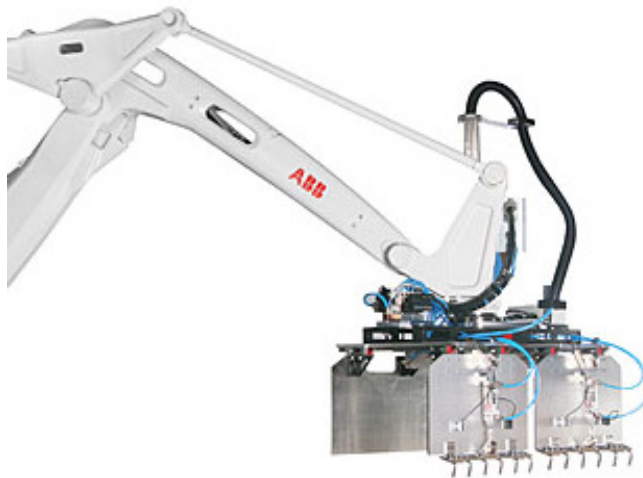

**Dual Zone Version**  
Weight 80kg

# FlexGripper – Clamp

## Key features



- **Wide clamping stroke adapts to different case width**
- **Rubber pad to increase friction force**
- **Sensors to verify presence / absence of case provided**
- **Hook unit provided as standard to ensure case clamping with high speed movements**



# FlexGripper – Clamp

## Adjustable clamp stroke

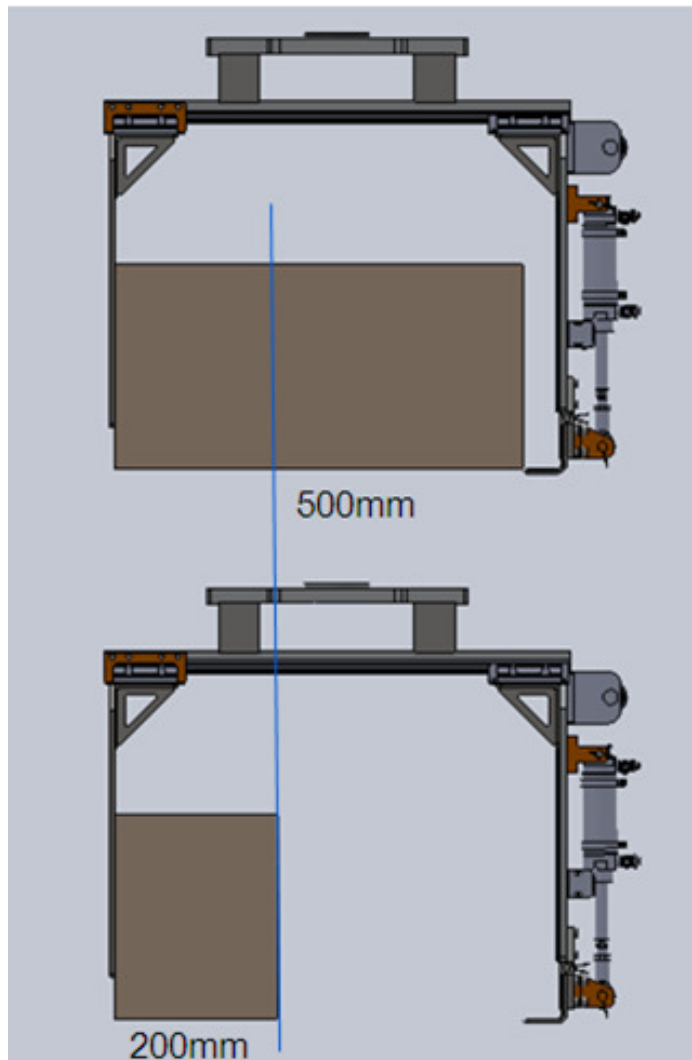

- Two ways to get a lean clamp stroke
  1. Adjust mounting location of the stationary plate
  2. Adjust mounting location of the pneumatic cylinder

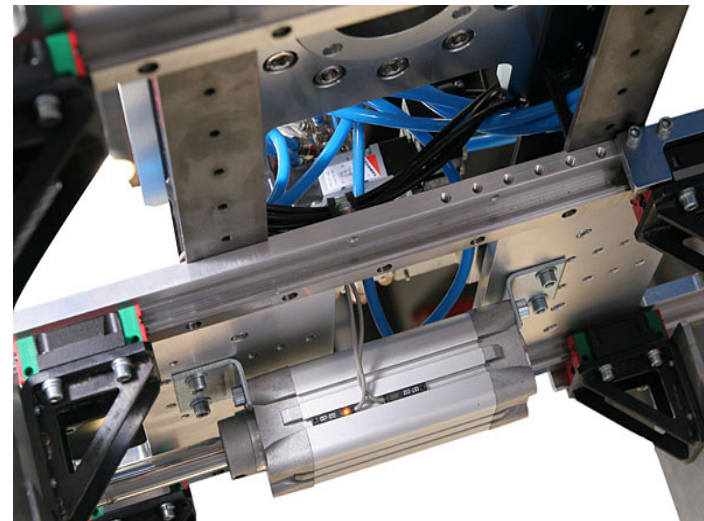

# FlexGripper – Clamp

## Key data

Specification	Data - 1 Zone	Data - 2 Zone
Optimized for:	IRB460	IRB660
Handled product	1-2	1-5
Max. weight/lift	40 kg	60 kg
Gripper weight	45 kg	80 kg
Case height range	150 - 330 mm	150 - 330 mm
Case length range	200 - 650 mm	200 - 1200 mm
Case width range	200 - 500 mm	200 - 500 mm
Cable rotation range	+/-180 °	+/-180 °
Air pressure (bar)	4-6 bar	4-6 bar



Dillion Liu, Product Manager, FlexGripper

# FlexGripper - Vacuum

# FlexGripper - Vacuum

## Key features

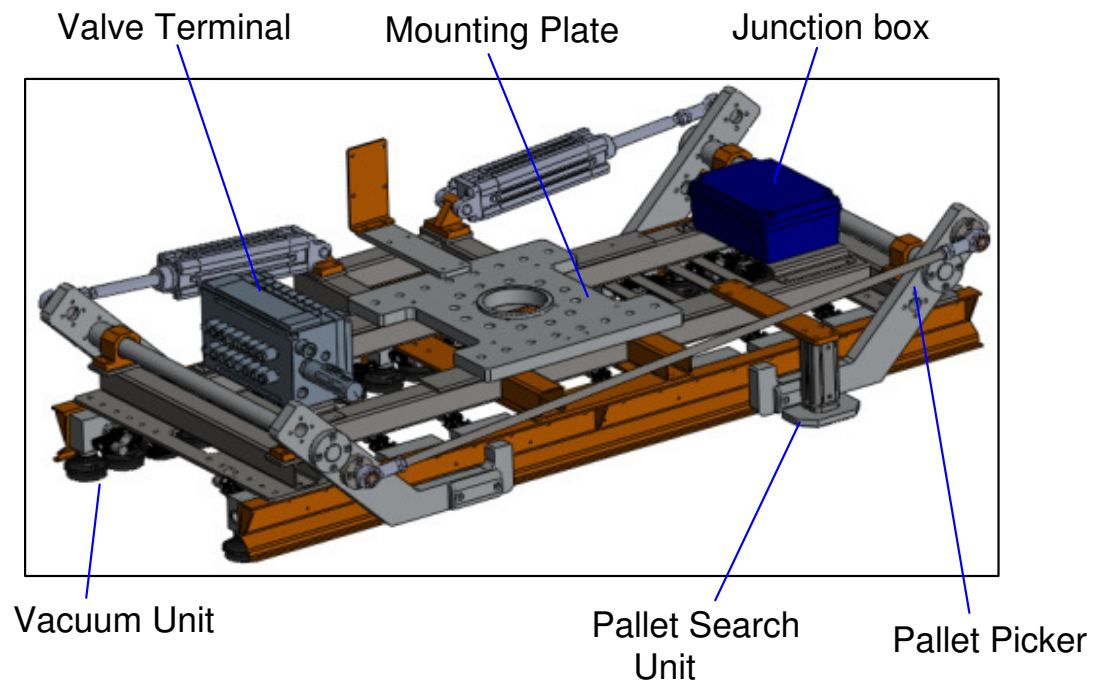

### Two main components:

- Vacuum rails
- Pallet Gripper

# FlexGripper - Vacuum

## Adjustable vacuum rails

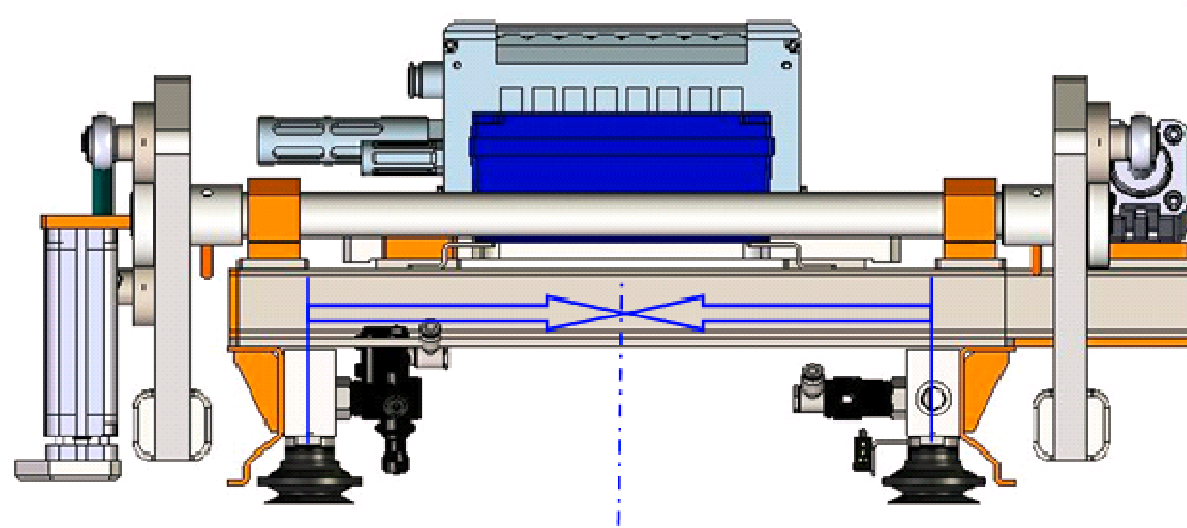

### Adjustable widths (mm)

180	210	240	270	300	330	360
-----	-----	-----	-----	-----	-----	-----

- The width can be adjusted from 180 to 360 mm measured from the centre of the both rails
- Max. product size (LxWxH) 1200 x 500 x 300 mm
- Min. product size (LxWxH) 240 x 240 x 100 mm

# FlexGripper - Vacuum Vacuum System

Specification	Data
Vacuum ejector	20 pcs
One way valve	20 pcs
Suction cup	40 pcs
Supplier	PIAB
Number of zones	10
Max.weight/lift	40 kg
Air flow	

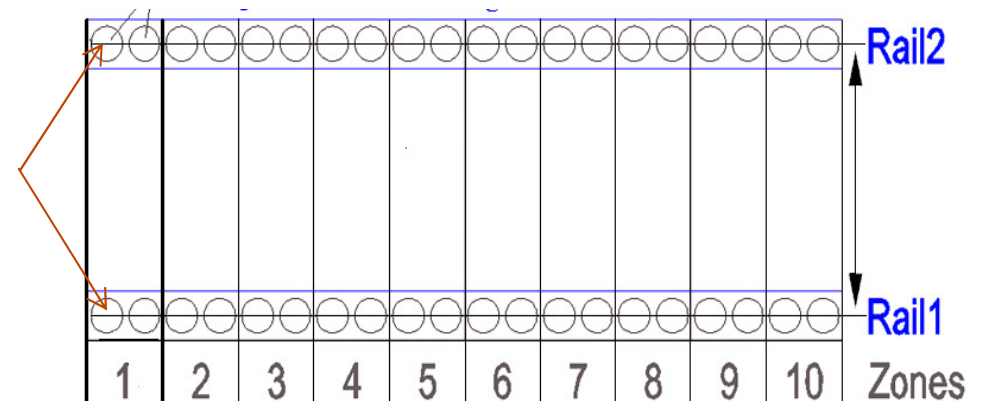
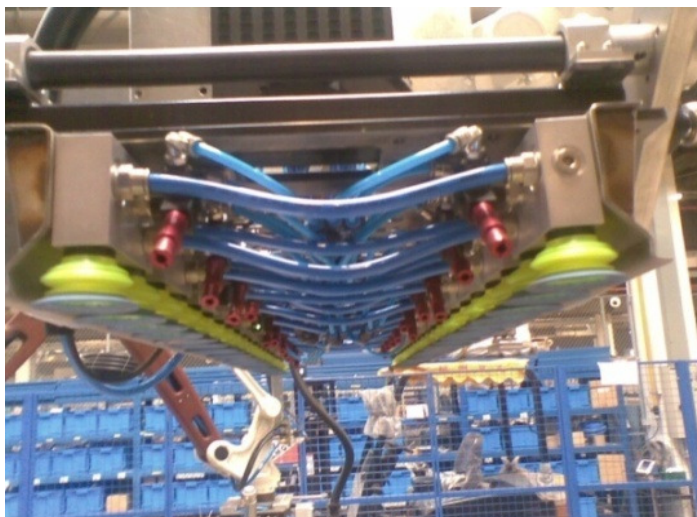

- 10 separate, programmable zones
- If leakage in one cup, no influence in other cups
- Fast release function
- Good result even on porous and uneven cardboard material

# FlexGripper - Vacuum

## Build in pallet gripper as option

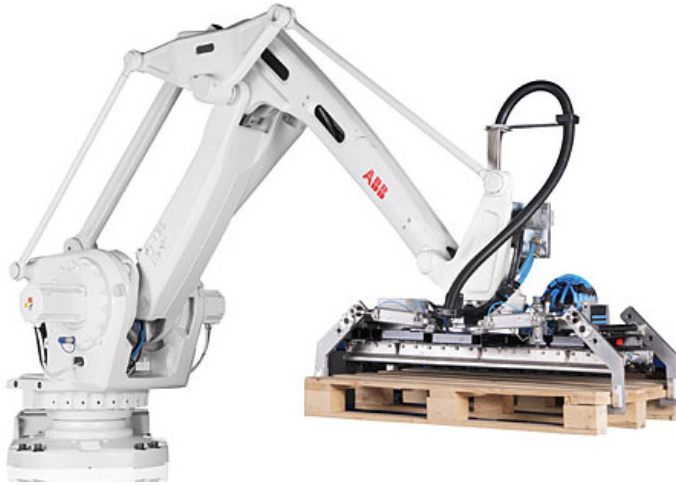

### Handling pallets

- GMA pallet 1016 x 1219.2 x 139.7 mm (L\*W\*H)
- EUR pallet 1200 x 800 x 144 mm (L\*W\*H)
- AUS pallet 1165 x 1165 x 150 mm (L\*W\*H)
- ISO pallet 1200 x 1000 x 144 mm (L\*W\*H)

### Search unit

- To locate the top of pallet stack

# FlexGripper - Vacuum Data sheet

Specification	Data
Handled product	1-5
Max. weight/lift	40 kg
Gripper weight	75 kg
Case height range	100 – 300 mm
Case length range	240 – 1200 mm
Case width range	240 – 500 mm
Cable rotation range	+/-180 °
Air pressure (bar)	4-6 bar
Handled pallet types	GMA/AUS/EUR/ISO



Dillion Liu, Product Manager, FlexGripper

# FlexGripper - Summary

# FlexGripper – Clamp, Claw, Vacuum

## Summary of key benefits



- **Reduced engineering time**
- **Reduced engineering cost**
- **Easy to integrate and easy to use**
- **Lean configuration and lightweight**
- **Graphical User Interface (GUI) provided on robot FlexPendant for easy gripper setup, tuning, and production monitoring.**
- **Shorter cycle times**
- **Fully supported by ABB Service**

Power and productivity  
for a better world™

