

4 Tooling for ABB Robots**4.1 Suction Cup Frame for ABB robot, built of Cross Tubes Ø38 mm, without Quick Change Adapter**

4.2 Suction Cup Frame for ABB robot, built of Central Tube Ø76 mm and Cross Tubes Ø38 mm, without Quick Change Adapter

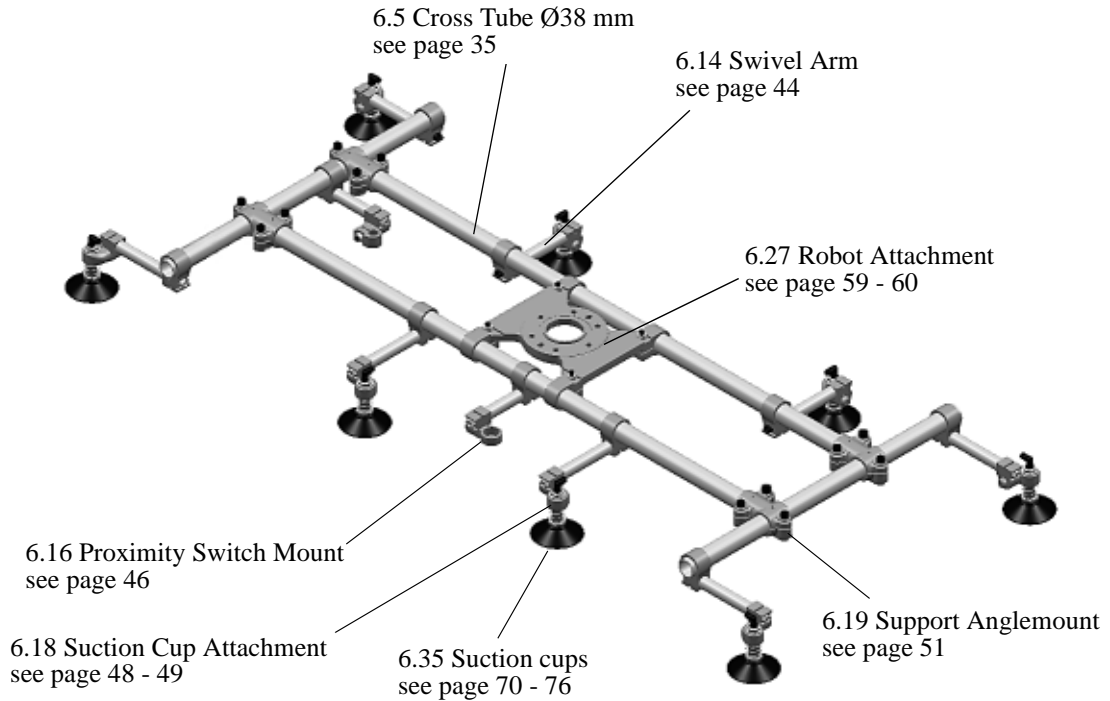
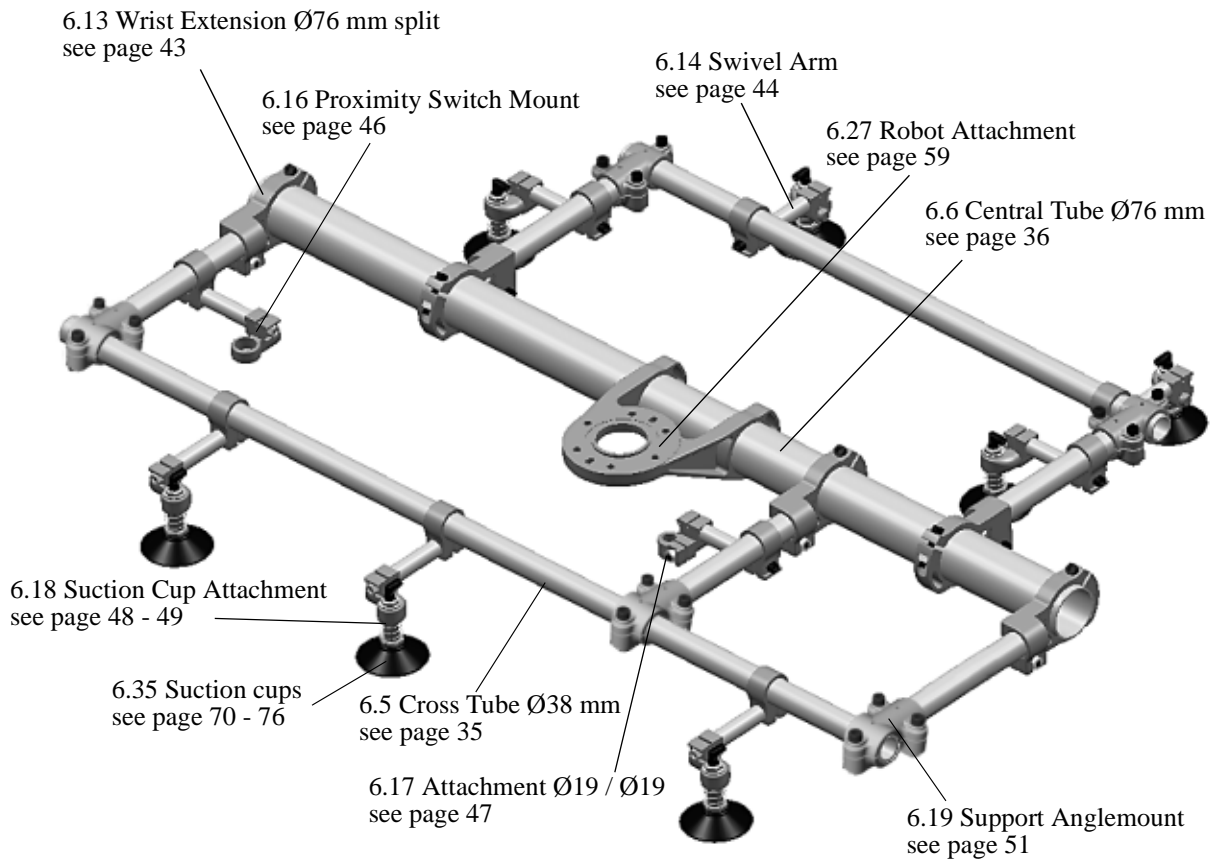

Filename: Kap4.fm, Mod date: 2005 04 07

4.3 Robot tooling with Tünker Attachments

6.27 Robot Attachment
see page 59

6.6 Central Tube Ø76 mm
see page 36

6.19 Support Anglemount
see page 51

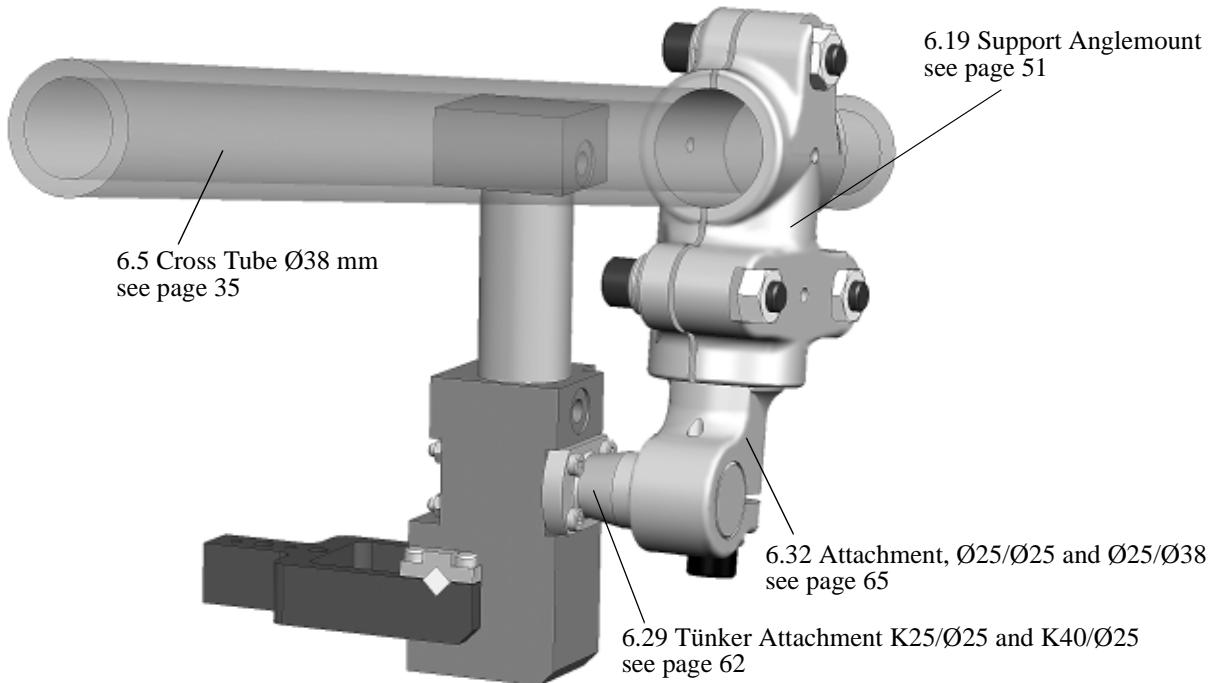
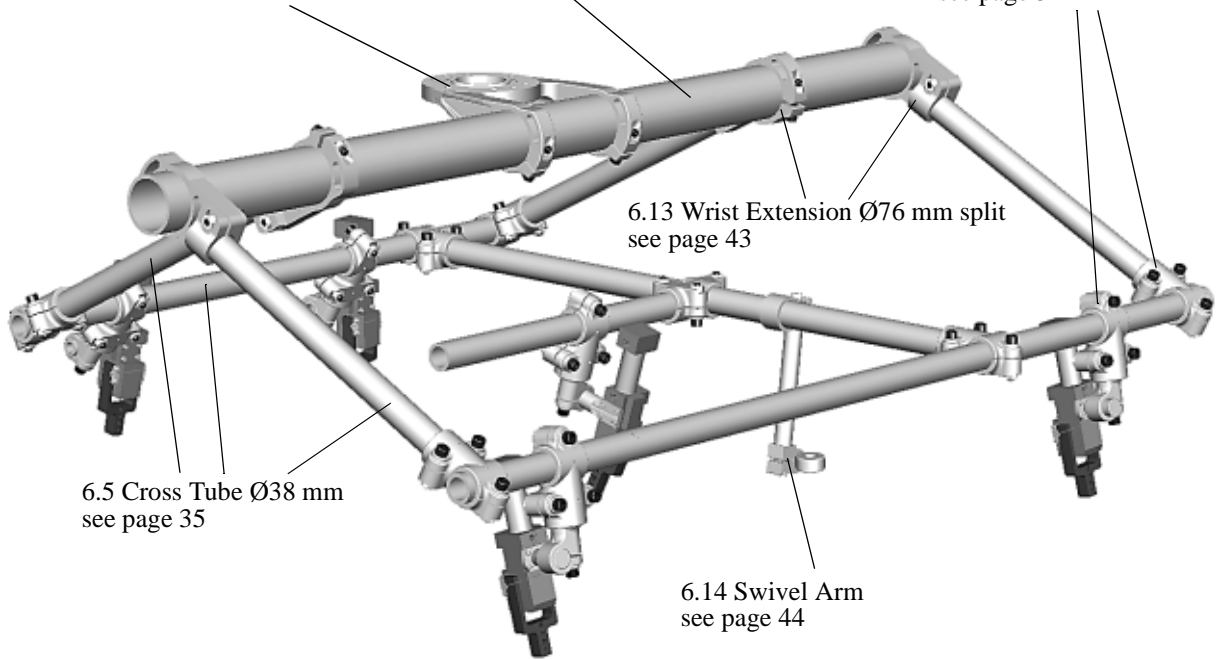

Filename: Kap4.fm, Mod date: 2005 04 07