

ABB heat recovery system

A new concept for optimal
waste heat utilization

The economical and ecological alternative
CO₂-free power generation from waste heat



ABB offers a completely new integrated system for the efficient utilization of waste heat in industrial plants – generating power from 500 kW upwards.

Are you facing the problem of high and rising energy costs? Are you required to reduce CO₂ emissions? If your answers are “yes”, we can offer you the perfect solution.

ABB heat recovery system

A flexible system solution

Due to its modular design, our system can be integrated in nearly all industrial processes. The application of the ORC (Organic Rankine Cycle) technology allows waste air or stack gases with temperatures starting from only 150°C to be economically used. The system basically consists of three modules:

- Intermediate cycle with heat exchanger
- ORC-power plant and standard components for power generation (evaporator, turbine, generator and control system)
- Cooling unit (condenser)

This modular design allows the maximum flexibility during the planning phase, installation and operation of the ORC-power plant.

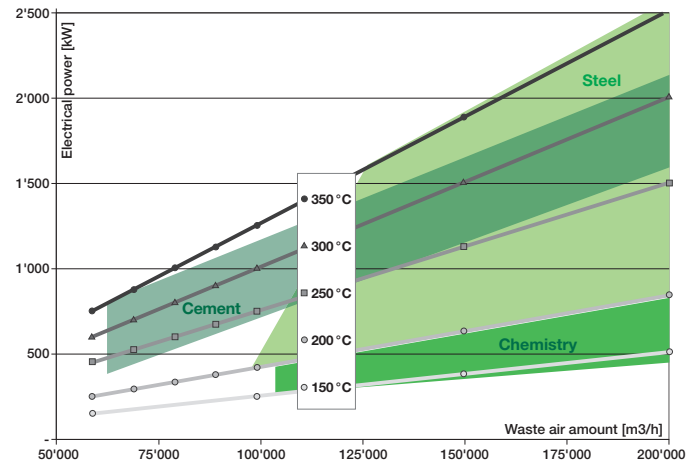

Application area starts from 150°C waste heat temperatures

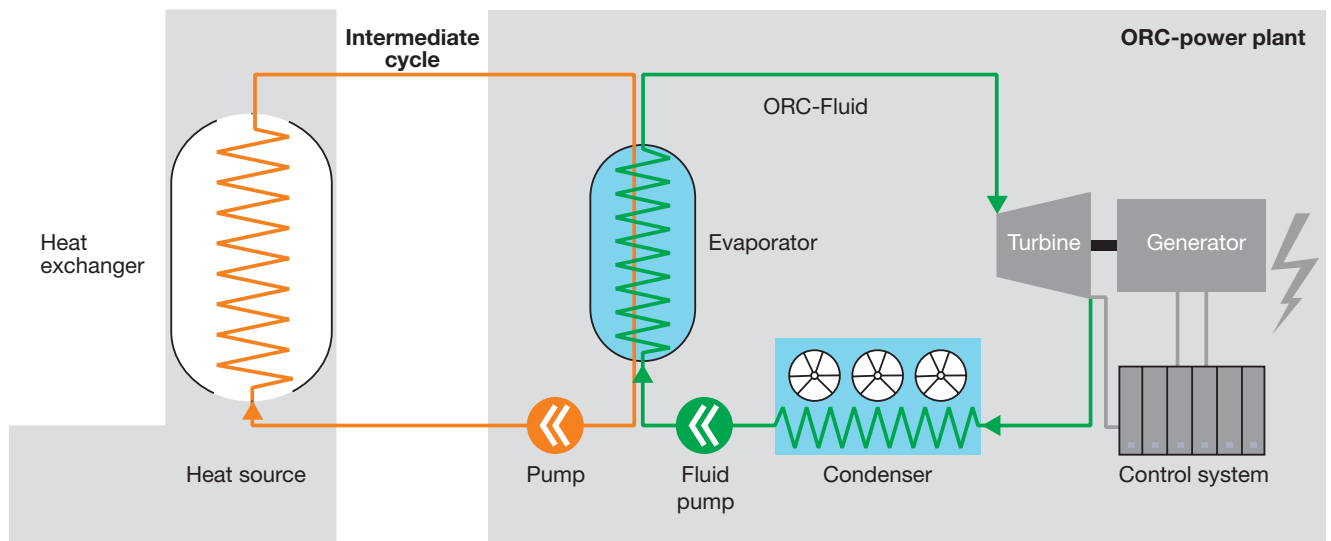

Functional principle of the heat recovery system

Raise your energy efficiency

Heat that was previously wasted can be converted into electricity – efficiently, economically and CO₂-free. This reduces energy costs and enables you to operate your company more efficiently and competitively.

With a good payback time, the profit zone is reached quickly. High profitability is guaranteed over a long timeframe, due to minimal maintenance costs.

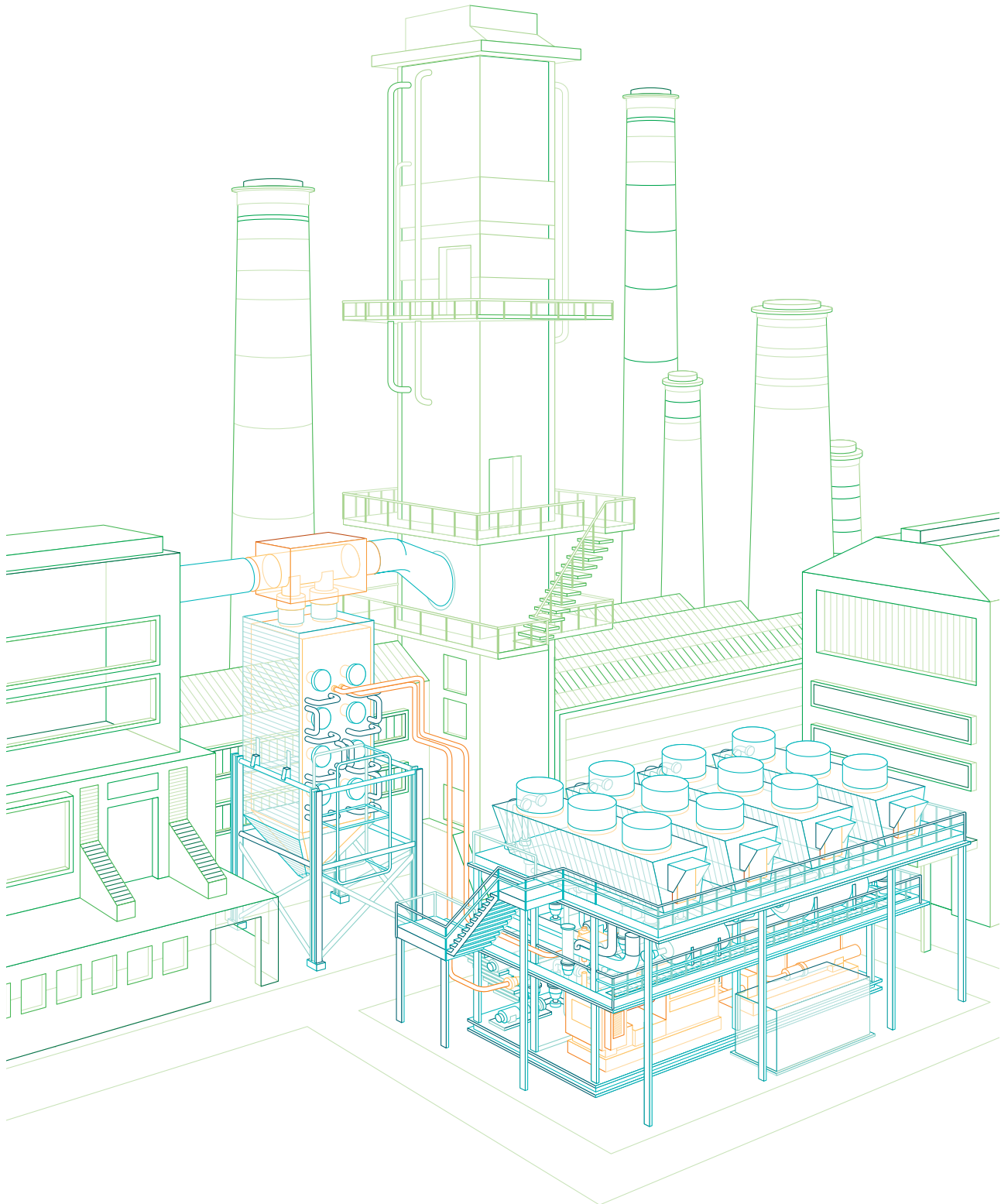

Our services

ABB assesses your industrial plants energy efficiency and then provides an analysis of the potential for improvement which can be realized using the ABB heat recovery system.

Following the analysis, ABB provides for you turnkey delivery and installation of the electrical power production system.

Summing up, these are your benefits

- Lower operation costs through own power generation
- CO₂-free power generation – a clear competitive and image advantage
- More independence from rising energy prices
- Plant operation with proven technology at low risk
- Fast installation through professional planning and execution
- Low capital expenditures due to standard components

Contact us

ABB Switzerland Ltd

Heat recovery unit

Segelhofstrasse 9P

CH-5405 Baden 5 Dättwil

Switzerland

Phone: +41 (0)58 586 84 44

Fax: +41 (0)58 586 73 33

E-Mail: hru@ch.abb.com

www.abb.com/minerals