

## **World Energy Congress, September 12-16, 2010, Montreal, Canada**

ABB Switzerland Ltd  
Center of Excellence for Minerals Processing  
Segelhofstrasse 9P  
CH-5405 Baden 5 Daettwil  
Switzerland  
E-mail: [process.industries@ch.abb.com](mailto:process.industries@ch.abb.com)

Authors:

Eduardo Gallestey: [eduardo.gallestey@ch.abb.com](mailto:eduardo.gallestey@ch.abb.com)

Gabriela Crosley: [gabriela.petras.crosley@ch.abb.com](mailto:gabriela.petras.crosley@ch.abb.com)

Andrew Wilson: [andrew.wilson@ch.abb.com](mailto:andrew.wilson@ch.abb.com)

Urs Maier: [urs.maier@ch.abb.com](mailto:urs.maier@ch.abb.com)

Rolf Hoppler: [rolf.hoppler@ch.abb.com](mailto:rolf.hoppler@ch.abb.com)

Thomas Boernert: [thomas.boernert@ch.abb.com](mailto:thomas.boernert@ch.abb.com)

### **Energy optimization and reduction of carbon footprint in cement manufacturing**

#### **Introduction**

The Kyoto Protocol which was adopted in Kyoto, Japan, on 11 December 1997 and entered into force on 16 February 2005 is an international agreement that sets binding targets for 37 industrialized countries and the European community for reducing greenhouse gas (GHG) emissions. These reductions amount to an average of five per cent against 1990 levels over the five-year period 2008-2012. The countries that have ratified the Protocol have developed their own methods for meeting these targets. One thing is clear however, cement production which alone accounts for approximately 5% of manmade CO<sub>2</sub> emissions will be one of the key affected industries.

On average producing one tonne of cement leads to the emission of 0.82 tonnes of CO<sub>2</sub>, meaning that with annual cement production in 2007 being approximately 2.6 billion tonnes that over 2 billion tonnes of CO<sub>2</sub> were produced by the cement industry alone.

The cement industry itself has not been slow to meet these challenges with various technologies being implemented to reduce the industry's carbon footprint. Some of the approaches are summarized below.

- Alternative Fuels
- Alternative Raw Materials
- Waste Heat Recovery
- Alternative cementitious Materials

To optimize the overall performance of a cement manufacturing unit requires a plant wide automation strategy. Reducing energy demand and carbon footprint in all areas must be combined with the search for the optimal operating point that is consistent with productivity and quality targets, and in line with imposed environmental emission limits.



*Figure 1: Holcim Untersiggenthal Plant, Switzerland, where ABB has delivered electrification, drives and optimization equipment*

### **Energy monitoring using Knowledge Manager.**

Helping cement manufacturers achieve their operational objectives is ABB's Knowledge Manager. Knowledge Manager is capable of gathering the information and data used by Expert Optimizer to model the process and to identify the best possible way of running the plant at all times.

Knowledge Manager provides the solutions and advanced tools needed to facilitate the collection, organization and distribution of combined production, quality and energy information throughout a plant organization via web-based reports, trends, and graphs. On a single page all relevant key performance indicators (KPIs) for the process are calculated and displayed. Additionally, if an operator wants to maximize production and at the same time maximize the usage of alternative fuels, Knowledge Manager provides the information for proper analysis to establish what is and is not possible.

Knowledge Manager can be adapted and expanded to meet each company's specific requirements and is part of ABB's CPM Minerals application suite which deals with production information monitoring and reporting. It drastically simplifies cement production management by covering manufacturing related functions such as:

- Production tracking and reporting
- Process operations monitoring and reporting
- Material storage management
- Energy and emission reporting

With Knowledge Manager, identifying the influences that process parameters have on product quality, production capacity, energy consumption and emission levels is now easier than ever. It combines production related data, process variability, energy indexes and run-time quality parameters to produce comprehensive operation and production reports and trends. The quality of these reports and trends results in the better utilization of energy, equipment, inventories and capacities.

Connectivity to Enterprise Resource Planning (ERP) systems (such as SAP) is essential to bring production data from the floor level to the enterprise management level. Here Knowledge Manager serves as the information broker between real-time control and its production environment, and the transactional based ERP systems.



Figure 2: Total energy report – thermal and electrical – with energy indicators

The cost of production is directly influenced by the energy usage. Different areas of production consume different amounts of energy, and Knowledge Manager tracks the amounts linked to the material being consumed or produced. (Figure 2).

With specific information available at the right time and at the right place in the right format, decisions become more goal oriented, resulting in optimized processes and increased productivity.

### Thermal energy savings using Expert Optimizer

Cement manufacturing is a complex and energy-intensive process. A key stage in this process is the conversion of ground raw materials ( $\text{CaCO}_3$ , clay and/or shale) into clinker (synthetic cementitious minerals) in the kiln. A typical operation uses kiln exhaust gases to preheat the raw materials -before they enter the kiln. Further heating, up to about  $1,500^\circ\text{C}$ , takes place in the kiln's burning zone where the materials are partially melted and react to form clinker. Subsequent processing, by grinding, is required to convert the clinker to cement. Small amounts of gypsum ( $\text{CaSO}_4$ ) are added and finally the mixture is ground to a fine powder.

Conventional control of a cement kiln requires the services of an experienced operator who must constantly interpret process conditions and make frequent adjustments to the set points established by the controller. This task is onerous enough, but it is made even more difficult by complex responses, time delays and interactions between individual process variables. As a result, conventional kiln control normally forces a conservative approach to kiln operation, with associated temperatures that are higher than the optimum leading to unnecessarily high energy usage.

Expert Optimizer, part of ABB's CPM Minerals application suite, is based upon the pedigree of proven successes from the well-known and highly regarded LINKman optimization system. It combines rule based control with modern tools like Neural Networks, Fuzzy Control and Model Predictive Control (MPC) (see Factbox). Expert Optimizer improves on conventional control by constantly interpreting kiln conditions and initiating appropriate actions. The various input and output signals are identified in Figure 3.

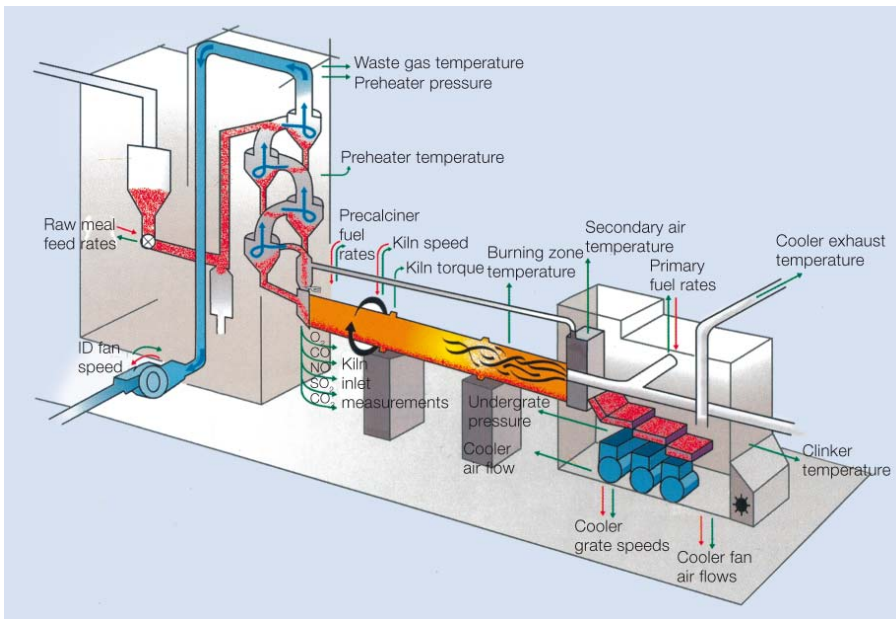

Figure 3: A kiln schematic showing the preheater for the raw material, kiln for the calcination process and grate coolers for the final clinker stage. This schematic also details the in- and output signals of an Expert Optimizer system

Proper and stable kiln operation can reduce energy consumption and maintenance costs, increase kiln output, and improve overall product quality. However, while optimum operation involves maintaining Burning Zone Temperature (BZT)<sup>1)</sup> at minimum levels consistent with stability, this is difficult to sustain for three reasons:

- Variations in raw material feed composition
- Complexity of kiln operation
- Long time delays between kiln operational changes (i.e. set-point changes and their effects)

The Expert Optimizer advanced kiln control system, however, operates the kiln in an optimum manner thereby ensuring a good quality product, lower BZT, and consequently, lower energy costs. The system achieves this by applying the appropriate level of expertise on a consistent and regular basis i.e. by making frequent changes.

Expert Optimizer is now typically in control of kilns for more than eighty percent of their run time. Calculations based on measured free lime and nitrogen oxide (NO<sub>x</sub>) levels before and after Expert Optimizer installation estimate that in some cases savings in terms of fuel consumption approach eight percent per kiln.

### **Fact box MPC Technology**

*(Extract taken from ABB Review 2/2004, pages 13-19)*

*There are several ways in which optimal solutions can be approximated. One widely adopted approach to solving control problems involving systems which are subject to input and output constraints is Model Predictive Control (MPC). MPC is based on the so-called receding horizon philosophy, ie, a sequence of future optimal control actions is chosen according to a prediction of the short- to medium-term evolution of the system during a given time. When measurements or new information become available, a new sequence is computed which then replaces the previous one. The objectives of each new sequence run are the optimization of performance and protection of the system from constraint violations.*

Footnote:

<sup>1)</sup>Burning zone temperature (BZT) is the predictor of product quality. If the BZT is low it is expected that the clinker will be insufficiently burnt and if the BZT is high it is expected the clinker will be over burnt

### **Kiln fuel mix optimization**

For some time there has been a need for tools that offer optimal management of the alternative and traditional fuels involved in the kiln process. In answer to this, Expert Optimizer has recently been enhanced with an *Alternative Fuels Optimization Module* that brings economic performance of kilns to new heights.

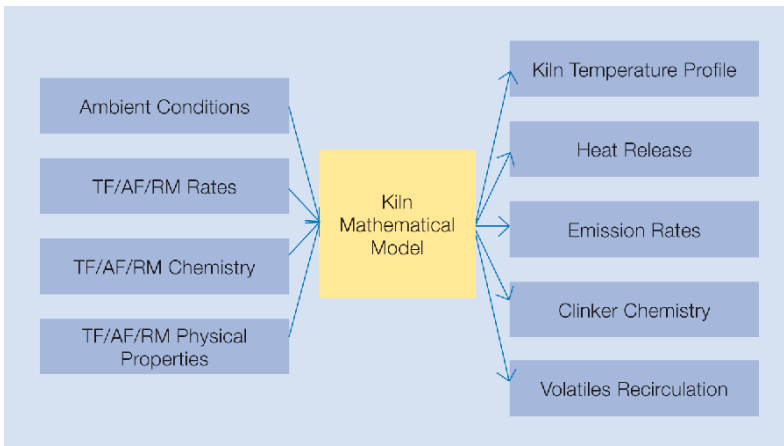

*Figure4: Holcim Ternate Plant, Italy, where clinker production was increased by as much as 8% and frelime standard deviation reduced by 25% by the use of Expert Optimizer.*

This module uses the data gathered by the information management systems (equipment, process, market, and laboratory) to calculate online the lowest cost fuel mix that satisfies the process and business constraints. The constraints to be satisfied are numerous but the most important ones are:

- Heat balance
- Excess oxygen level
- Clinker chemistry
- Volatiles concentration
- Emission limits (SO<sub>2</sub>, NO<sub>x</sub>, etc.)
- Maximum, minimum and speed of change constraints on actuators
- Operative constraints on fuel consumption
- Separate consideration of combustion process in precalciner and kiln
- Contracts (with customers or suppliers) to be satisfied at any cost

The basic element of this optimization algorithm is a dedicated kiln mathematical model developed in Expert Optimizer, which is used to implement the (model predictive) controller (see figure 5) . This model can estimate cooler, flame, burning zone, backend and preheater temperatures, kiln energy requirements, emission and volatiles levels, etc. The optimization algorithms are able to cope with both hard and soft constraints, and this enhances robustness and reliability of the optimization process.



*Figure 5: Typical cement kiln model – inputs and outputs*

The input data is updated at sampling times of about 15-30 minutes, computations are executed and the new fuel setpoints are passed to the Expert Optimizer strategy module for implementation. Between sampling times, the “standard” Expert Optimizer strategy guarantees process stability and the highest performance. In particular, this strategy enforces economically optimal reactions to changing conditions in fuel, waste, and raw meal quality as well as ensuring strict satisfaction of the environmental, contractual and technical constraints.



*Figure6: ABB control system, Expert Optimizer and Knowledge Manager are installed at the Jura Cement Plant, Switzerland*

### **Variable Speed Drives – an electrical -energy saver**

In the cement manufacturing process large fans draw air through the kiln, precalciner, mills and filters to an exhaust stack. Many smaller fans push the air into the grate cooler to reduce the temperature of the hot clinker leaving the kiln (see figure 3). All these airflows have to be adjusted and controlled as atmospheric conditions, process conditions and ventilation needs greatly effect the flow requirements. The control method employed has a major effect on the running costs. For example, a damper with a fixed speed motor is the least energy efficient solution and the application of variable speed drives (VSD) is the most energy efficient. To be more precise, depending on the required flow rate, power savings of up to 70 percent can be achieved when the two are compared.

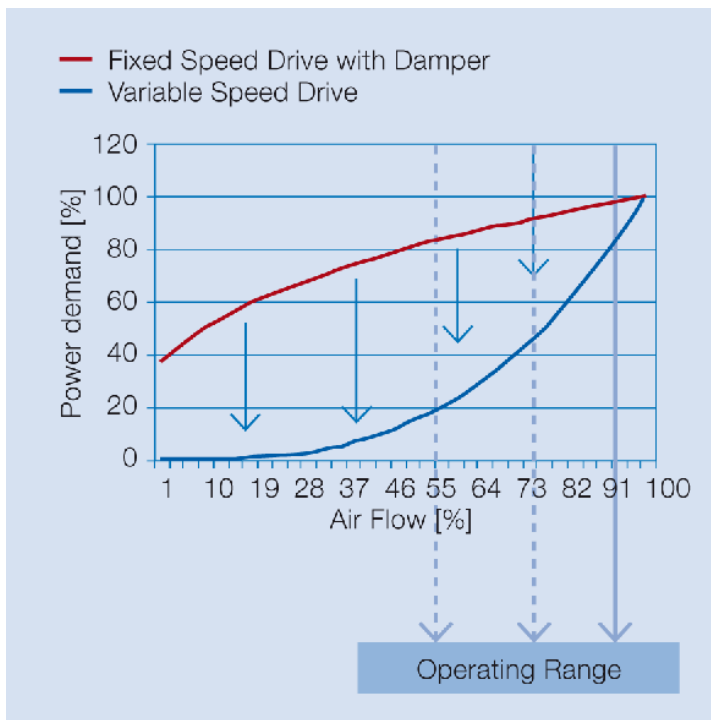

Figure 7: Power demand in percent of airflow using a damper and a variable speed drive

The difference in power demand for an air flow controlled fan is shown in figure 7. Fans are predestined for saving energy due to a quadratic load characteristic. Normal operation of large fans consumes about 90 percent of nominal air flow, which still represents a potential saving of 20 percent power. Nowadays VSD for large fans are usually installed in all new plants. However the potential for large energy savings still exists in fan replacements, especially in the cooler area.

### Optimized solution for Grate Coolers – Multidrive

Approximately 10 percent of the electrical energy required to produce one ton of clinker is needed to cool it. It therefore makes good sense to give careful thought to the choice of drive system for the cooler. One such choice is the Multidrive which is often referred to as an “optimized drive solution for the cooler area”. It offers all of the benefits of VSD and eliminates, in an economical sense, many of the drawbacks of single drives. Unlike single drives (which have to have their own rectifier, DC link and inverter), the Multidrive system generates the required DC voltage in a “central” unit and feeds it onto a common DC bus to which the single, independently operated inverters are connected (figure 8). In a Multidrive system all the desirable features of a single drive are still retained. In addition, the individual inverters do not all have to have the same power rating. On the contrary, a Multidrive package can consist of drives of very different sizes.

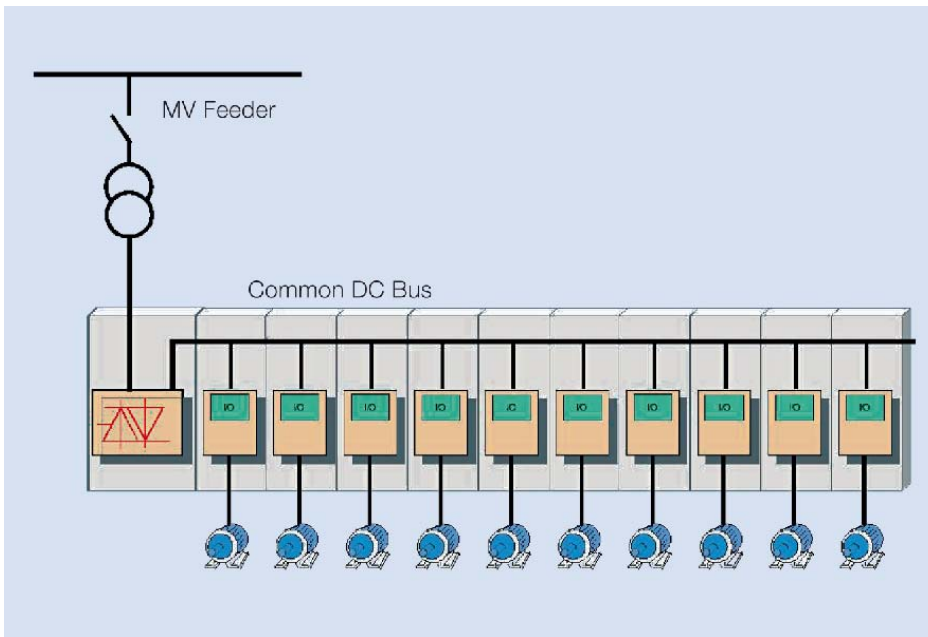

Figure 8: A Multidrive system layout.

Some of the benefits of such a system include:

- *Reduced cabling* due to the single power entry for multiple drives.
- *Energy-saving motor-to-motor braking* which is required depending on the grate cooler type.
- *Reduced space requirement*
- *Elimination of the low voltage distribution* used for single drives or dampers and direct online motors in cases of replacement.
- *Cost effective reduction of harmonics* using an active front end supply unit or at least a 12-pulse line supply.
- All the benefits of a single VSD are retained.

### **Optimized solution for Downhill Conveyors – Active Front End (AFE) technology**

Long distance belt conveyors have always been a challenge for drive and control applications. There are several methods of applying the drive. Different drive systems have to be provided to suit the topographical conditions, the material to be transported, the environmental requirements and the operating methods.

For downhill conveyors between the quarry area and the raw material section of a cement plant - because of operational requirements - the drive has to have an adjustable speed and should be capable of regenerating the power on the downhill section. A new technique, the Active Front End (AFE) technology, can be applied. Nowadays all operating processes are monitored by sophisticated control systems. One of the big advantages claimed for this technology is that it is “extremely network friendly”. All the environmental requirements are fulfilled by the use of a tube conveyor and examinations of the energy balance from the aspect of the active power taken out of the network and the regenerative power fed back into the network.

For the downhill belt conveyor from the new quarry to the raw material section, a Swiss cement manufacturer ordered the AFE solution. ABB delivered a multi drive systems consisting of one supply section, regenerative, active front end, 5 inverters and 5 variable voltage, variable frequency (vvpf) 160 kW motors.



The energy efficient solution generates the following benefits:

- The applied AFE technology is capable to regenerate from the downhill section annually 800 000 kWh back to the grid.
- No reactive power,  $\cos \varphi=1$
- Low level of harmonics
- High efficient drive system
- Less energy consumption
- Smooth belt operation
- Extremely network friendly



*Figure 10. Downhill section, Vigier Cement Plant, Switzerland, equipped with ABB AFE technology, regenerating annually 800 000 kWh back to the grid*

### **Heat Recovery in Cement Plants**

As mentioned in the introduction the production of one tonne of cement generally leads to the emission of 0.82 tonnes of CO<sub>2</sub>. The CO<sub>2</sub> itself generally comes from three sources. Firstly there is CO<sub>2</sub> produced by the thermal decomposition of CaCO<sub>3</sub> according to the following equation

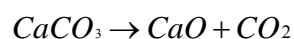

Secondly, there is CO<sub>2</sub> produced by the burning of fossil fuels required to reach the high temperatures in the cement kiln necessary for the formation of clinker. Thirdly, there is CO<sub>2</sub> that has been produced in the production of the electricity which is used extensively in the cement making process (~105 kWh/tonne cement).

Cement manufacturers currently use a number of technologies to address the first two sources of CO<sub>2</sub>. These include maximising the use of alternative raw materials, burning alternative or waste fuels and increasing the thermal efficiency of the cement-making process.

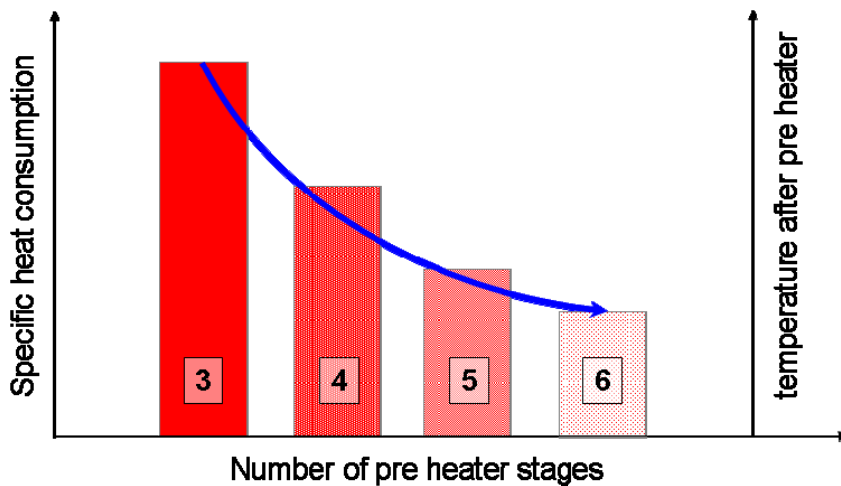

Figure 11- Specific Heat Consumption vs. Preheater Tower Stages

Figure 11 shows that by designing cement preheater towers with more stages a decrease in the temperature after the preheater has been achieved and at the same time a reduction in the specific heat consumption of the whole process. There is however a case of diminishing returns as you increase the number of preheater stages. This is due to the fact that the heat recovered per additional stages drops, especially after 5 stages and at the same time each additional stage leads to additional pressure drop across the system as a whole, increasing the electrical energy consumption of the preheater fan.

### Heat Recovery Technologies

The most commonly used technology employs the waste heat from the preheater and the cooler to generate steam from water in a heat exchanger. The steam is then used to generate electricity in a turbine. Over the last 20 years the technology has been refined enabling lower temperature waste heat to be used for generating electricity. Waste heat generation plants based on the steam turbine technology are still however sensitive to the inlet temperature and require significant space for installation of boilers, steam turbines, etc.

The ABB Heat Recovery System operates with the Organic Rankine Cycle (ORC) to use low temperature waste heat sources for power generation (see figure 10). The waste heat plant consists of:

- Heat exchanger and thermal oil cycle
- Power container with standard components of the power generation (turbine, generator) and evaporator
- E - container (control system and electrical equipment)
- Cooling unit (condenser)

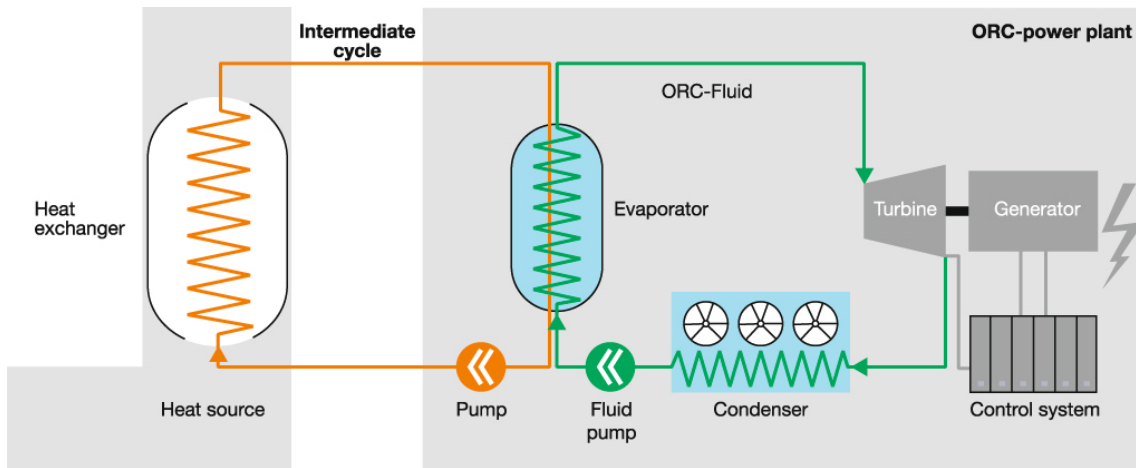

Figure 12: Functional principles of ABB Heat Recovery System

Some of the major benefits of the ABB Heat Recovery System compared to other technologies include:

- Compact modular concept
- Simply designed heat exchangers
- Low temperatures in the organic cycle allowing cooling of waste heat source to low temperature leading to wide exploitation of waste heat energy
- Automatic operation without personnel
- Low operation and maintenance cost

Naturally each potential application needs to be assessed on its merits, but a reduction of at least 15% in electricity consumption and the associated CO<sub>2</sub> should be expected.

### Electrical energy management

Cement production runs 24 hours a day with very limited spare capacity or redundancies installed. Thus, most of the equipment has to run around the clock, or if there are other constraints, during daytime like the quarry. The degrees of freedom available for electrical energy usage are therefore very limited and are mainly restricted to the cement grinding area. In this area, the decision on when to produce a certain cement grade, in which mill, is performed manually using heuristic rules and relying on operator experience. However, the numerous mills, grades and silos, plus the various operating and contractual constraints, make the problem a complex one. Too often, the operator's choice is far from optimal. The solution described in the following text uses optimized scheduling based on MPC technology.

A typical mill on/off sequence and scheduled cement grades for effective electrical energy management is shown in figure 9. Using customer orders and energy price forecasts, the algorithm produces a reference schedule for the entire grinding plant operation defining what each mill will produce and when in time. Here the modeling functional represents costs associated with electricity consumption and the amount of low grade cement produced (cement produced during the switch from one grade to another). Electricity cost reduction is achieved by committing the production to time periods when the electricity tariffs are lower, and by making sure that contracted thresholds of maximum electrical power are not exceeded. Reductions in low grade cement are obtained by penalizing the number of production switches.

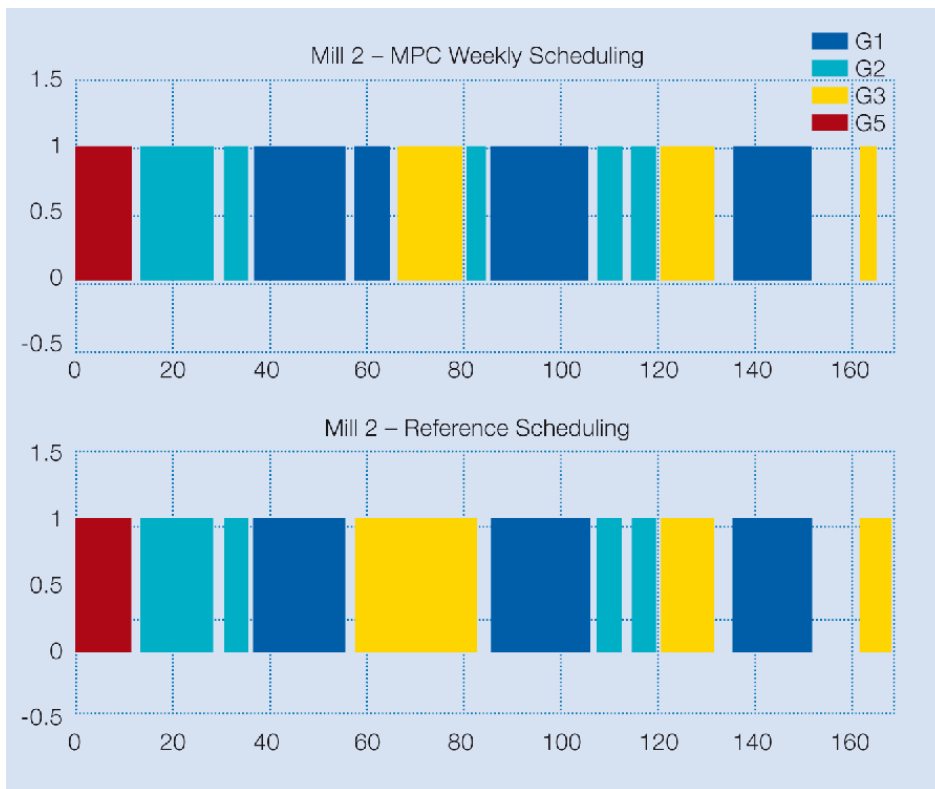

Figure 13: Typical mill and cement grade schedule

In addition to the physical constraints imposed by the silo capacity and mill availability, other constraints must be considered:

*Transition time:* A change of grade being produced by a mill might cause a time delay during which the mill throughput is conveyed to a special silo.

*Order satisfaction:* As input, the optimization algorithm requires sales forecasts for every grade. If the sales forecast cannot be completely fulfilled, the algorithm will choose which grade to produce first according to a given ranking.

*Transport system:* Whether it is by conveyor belts, bucket elevators or air based systems, there are constraints on the system for transporting the cement from the mills to the silos. For example, there might be three mills but just two independent transport routes. However, multiple mills can simultaneously discharge the same cement grade to the same transport route. On the other hand, one route can serve only one silo at a time and silos can be served by only one route at a time.

### Summary

As shown in the above cases, energy conservation deals with different aspects of process optimization; resulting in reduced thermal and electrical energy demand, and/or reduced costs using less expensive energy and fuel mix. Today, reliable equipment and proven technical solutions are available to ensure the efficient use of energy without jeopardizing the quality and productivity of a plant. The suite of available and integrated solutions discussed in this paper; Variable Speed Drive (VSD), Expert Optimizer, Knowledge Manager, Heat Recovery are perfect examples of how a plant wide strategy can achieve such goals. Since energy prices continue to fluctuate (tending towards an overall increase) the investment pay back time is good. In addition it has a positive ecological and environmental impact. All achieved while improving the bottom line.

## References:

1. ABB Review 2/2007, The energy optimizers
2. ABB Review 2/2004, New levels of performance for the cement industry
3. International Cement Review 3/2005, Expertly boosting output
4. Cement International 5/2006, Active front end technology (AEF) as applied to a downhill conveyor
5. ZKG International, 2/2005, An optimized drive solution for the cooler area
6. World Cement, 3/2009, Energy expertise
7. ABB Review, 2/2009, Optimal Trade-offs - Achieving energy efficiency and environmental compliance is not a problem thanks to advanced process control
8. TCMA November 2009, Paper, Boost energy efficiency by converting low temperature waste heat to electricity