

MOCT Optical Current Transformer System for Metering

72.5-800 kV Systems, 50/60 Hz

Application

The Magneto-Optic Current Transformer (MOCT) is a passive optical current transducer which uses light to accurately measure current on high voltage systems. The MOCT system is suitable for outdoor application and has an accurate metering current range from less than 1 A to 4000 A using the same sensor. Higher current rated designs are available upon request.

The system is provided with one electronic module that is located in the control house.

The MOCT system provides a 1.0 amp current output for metering. Contact the factory for application assistance.

- Three phases of MOCT sensors mounted on polymer insulator columns with preterminated fiber optic cable in the insulator.
- Electronic MOCT signal processing module 2100-I suitable for installation in the substation control house.
- Fiber optic cables for transmission of the light signals between the optical sensors and the MOCT electronic module.
- Phase columns can be mounted horizontally or under hung.
- Metering accuracy:
ANSI class 0.15 s, 0.3
IEC class 0.2 s

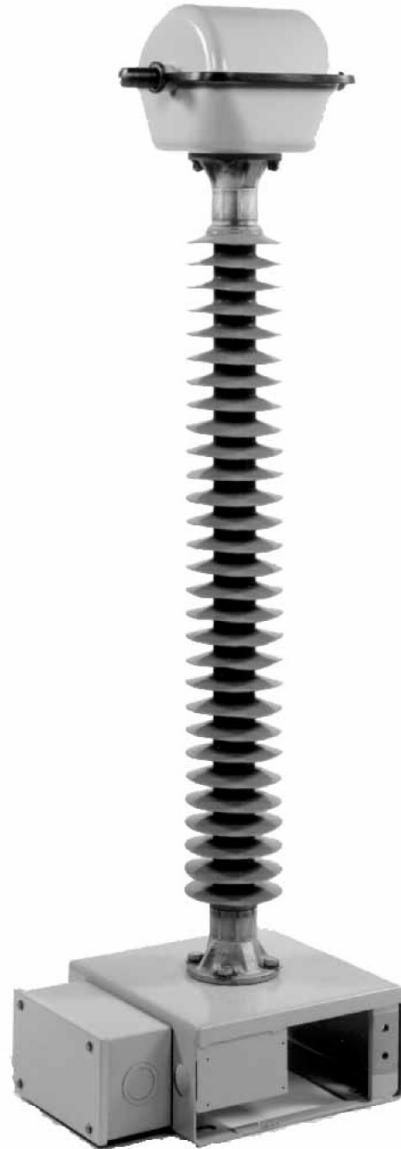

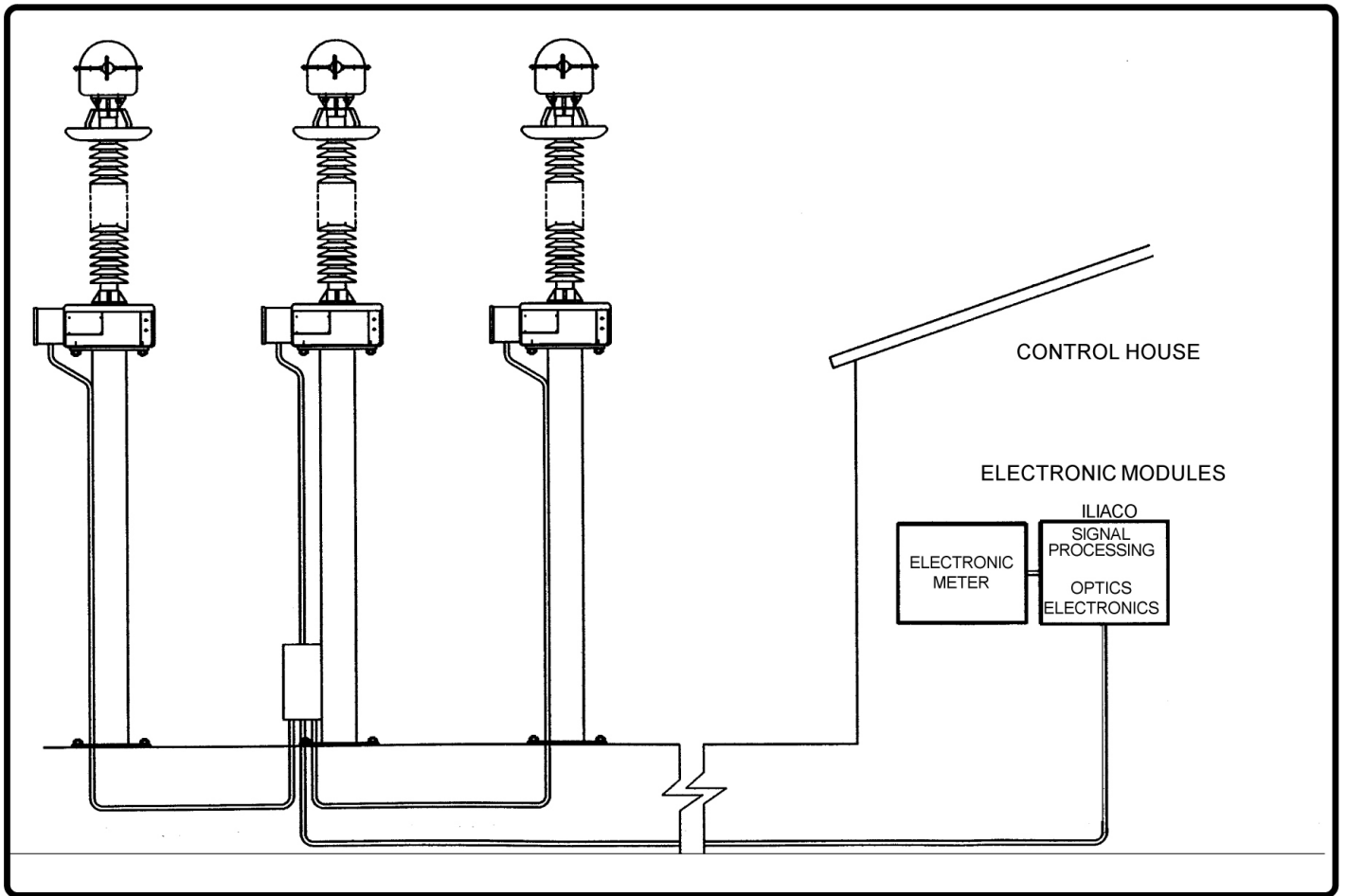

MOCT System Configuration

Benefits of the MOCT Optical Current Transducer System

The MOCT system can satisfy current sensing needs for revenue metering in a wide variety of applications. Following is a list of key benefits:

- High accuracy for metering over a wide range of primary currents.
- No requirement for oil or gas insulation system.
- Improved safety with no mechanism for failure or open secondary.
- Significantly smaller size and lighter weight than oil- or SF₆-insulated equipment.
- Total isolation from surges for microprocessor-based meters and relays.
- No magnetic core ferroresonance or saturation limits.
- More than 15 years of field proven experience.

All dimensions in inches unless specified otherwise

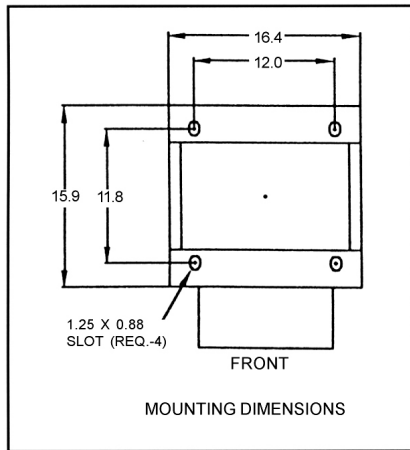
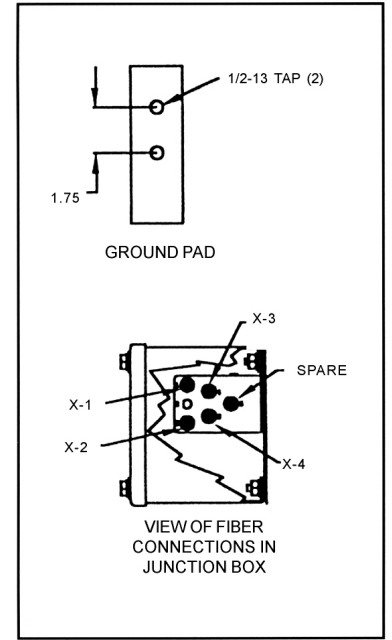
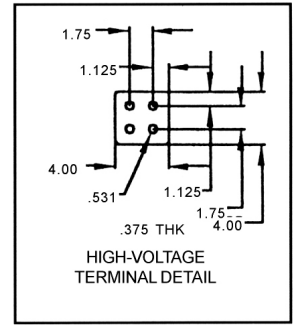
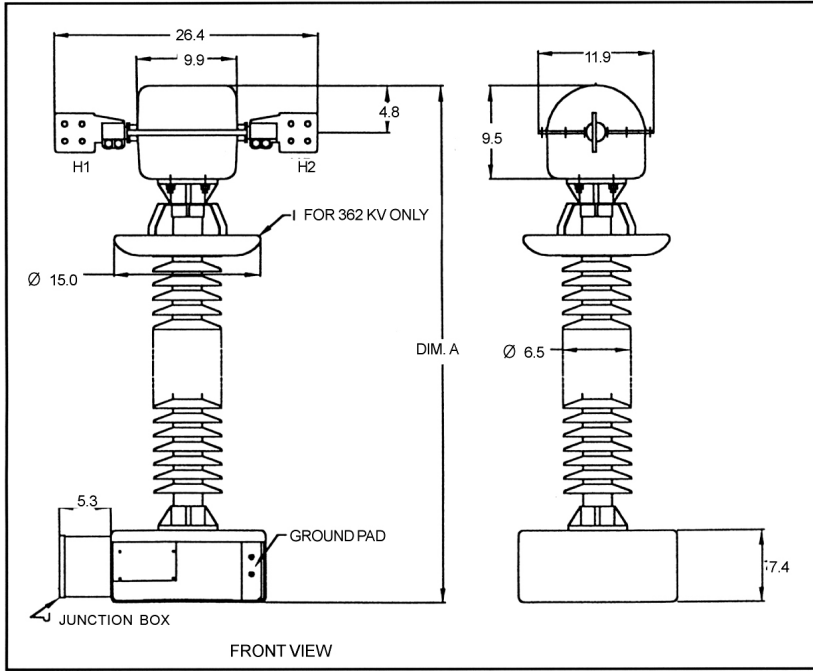

Maximum System Voltage kV	BIL kV	Dimension A		Minimum Creep Distance		Weight	
		inches	mm	inches	mm	lbs.	kg
72.5	350	48.9	1242	70	1778	110	50
121	550	62.6	1590	113	2870	117	53
145	650	70.2	1783	137	3479	120	54
169	750	79.3	2014	165	4191	123	56
242	900	97.5	2477	222	5638	133	60
245	1050	109.6	2784	260	6604	139	63
362	1300	132.0	3355	272	6900	348	158
525	1800	191.2	4856	433	11000	410	186
800	2050	Contact Factory					

For more information please contact:

ABB Inc.
High Voltage Products - Optical Sensors and Systems
Westmoreland Distribution Park East
100 Distribution Circle
Mount Pleasant, Pennsylvania 15666, USA
Phone: +1 (724) 696-1500
Fax: +1 (724) 696-1502
www.abb.com/highvoltage