



CQ900
Capacitor controller

Installation and Operation Manual

Copyright

All rights reserved. No part of this material may be reproduced or utilised in any form or by any means, electronic or mechanical, including but not limited to, photocopying, recording or by information storage or retrieval system, without prior written permission from ABB Australia Pty Limited.

Caution

The information in this document regarding the installation of the *CQ900 Smart Controller* is for qualified people who are trained to work with this type of equipment and who understand the hazards that may be involved. The information on installation is not a substitute for training. Correct safety procedures must be followed at all times.

Trademarks

Windows™ is a registered trademark of Microsoft Corporation.

All other trademarks are the property of their respective holders.

Table of Contents

Copyright	ii
Caution	ii
Trademarks	ii
About this manual.....	vii
Audience	vii
Conventions used in this manual	viii
SECTION 1:.....	1
CQ900 CONTROLLER OVERVIEW.....	1
Capacitor Bank Overview	1
Features	2
Front Panel View	4
Front Panel Features	5
Configuring the Unit.....	7
SECTION 2:.....	8
HARDWARE / SITE INSTALLATION (INCLUDING WIRING TABLES/DIAGRAMS)	8
Installation Checklist	8
Mounting the Controller (Standard Installation)	9
Mounting the Controller (Meter Socket Installation)	10
Grounding the Unit	10
Typical Polemount Capacitor Bank Installation	11
Configuration of the Voltage Transformer.....	12
Configuration of the Current Sensor	12
Testing the Controller Operation	13
SECTION 3:.....	14
CQ900L UNIT SETUP AND BASIC OPERATION	14
Using the Front Panel (Automatic Mode)	14
Using the Front Panel (Manual Mode).....	15
Opening and Closing the Switches	15
Navigating around the menus.....	15
Status displays.....	17
Using the menus	18
Options available for setting / viewing in the System Config menu	18

Options available for setting / viewing in the Operation Config menu	19
Options available for setting / viewing in the Schedule Config menu	20
General Operation and Function Information	21
Real-Time Clock/Calendar	21
Operational Mode	21
Current Sensor Measurements	21
Neutral Current Sensor Measurements	22
Auto Jump-back Feature	22
Reverse Power Action	22
Data Logging Operation	23
Alarm Status Auxiliary Output Operation	23
Switching Rules & Restrictions	24
Switch Synchronisation	24
Auto-Switching Control Functions	24
Switching Actions	25
Schedule Switching Control	26
Week Structure	26
Seasonal Structure	26
Work day / Non-work day Switch Schedules	26
Daylight Savings Operation	26
Holiday Schedule	26
Voltage Switching Control	27
Voltage Thresholds	27
Operational Example (Voltage Only)	29
“Voltage Only” Important Notes	30
Temperature Switching Control	30
Temperature Thresholds	30
Operational Example (Temp Only)	31
“Temperature Only” Important Notes	31
Var Switching Control	32
Var Thresholds	32
Application notes for var control switching:	33
Current Switching Control	33

Current Thresholds.....	34
Application notes for Current control switching:.....	34
Combination Auto Switch Settings.....	34
Controller Alarms	35
Active Alarm Descriptions	35
History Alarm Descriptions	36
CQ900 Controller Alarm Listing.....	36
Checklist for configuring a new unit	37
<i>Optional settings</i>	37
SECTION 4:.....	38
PC UTILITY SOFTWARE OPERATION	38
Minimum hardware and software requirements	38
Installing the Software	39
Software compatibility.....	39
Software Start-up and Levels of Access	39
PC Utility Software Control Tabs.....	41
Connect Tab	41
Monitor Tab	44
System Tab.....	46
Operation Tab	47
Schedule Tab	48
DNP3 Tab.....	51
Service Tab	51
SECTION 5:.....	55
DNP3 Communication Configuration and Operation	55
DNP3.0 PC Utility Software Configuration Tab	55
DNP3 RS232 plug and cable configuration.....	58
Radio / Modem devices	59
DNP3.0 Points list.....	60
Binary inputs	60
Analogue inputs	62
Binary Counters.....	63
Binary outputs.....	63

SECTION 6:	65
CQ900 SMART CONTROLLER SPECIFICATIONS	65
SECTION 7:	68
PART NUMBER AND ORDERING INFORMATION - HARDWARE WIRING CONFIGURATION	68
7 – Pin Panel Plug Configuration	69
Controller Cable Socket Configuration.....	70
Meter Base Socket signal outputs.....	71
Appendix A: Front Panel menu structure flowcharts	72
Display menu structure.....	72
System Config Menu Structure.....	73
Operation Config Menu Structure.....	74
Schedule Config Menu Structure.....	76

About this manual

Manual Revision:	1.4
Manual Revision Date:	16/09/11
Revised by:	Timothy Heemskerk

This manual describes the set-up and operation of the ABB *CQ900* range of *Smart Controllers*. Given the basic operation similarities between the CQ900L and CQ900R models, this manual can be applied to both with differentiation between the two noted as required.

Contents include:

- Overview and description of the *CQ900 Smart Controller* (Chapter 1)
- Site installation and hardware configuration instructions (Chapter 2)
- Detailed Set-up and user guide of the CQ900 (Chapter 3)
- Operation instructions for the supplied PC Utility Software (Chapter 4)
- Connection and set-up instructions for DNP3 remote communications (CQ900R models only) (Chapter 5)
- Quick reference to the CQ900 specifications (Chapter 6)
- Part number and ordering information – Including wiring configuration and pin assignments (Chapter 7)
- Flowchart of items available within each menu when operating the CQ900 through the unit faceplate



Audience

The intention of this manual is for use by installation technicians and who undertake the field installation of the *CQ900 Smart Controller* and/or suitably qualified persons who perform the initial factory set-up of the controller unit.



Warning: The installation descriptions contained within this manual should only be undertaken by qualified people who are trained to work with this type of equipment and who understand the hazards that may be involved. The information on installation is not a substitute for training. Correct safety procedures must be followed at all times.

Conventions used in this manual

Terminology	Description
Bold Arial Font	<ul style="list-style-type: none">• A keyboard stroke.• A field on the PC software screen• A push button on the controller
<i>Italics</i>	Product, software and manual names.
 Note:	Indicates a note, containing more detailed description of an Event/Action. E.g. A short cut method to perform a procedure.
 Warning:	Indicates an important point that should be read carefully and taken note of before proceeding further.
<input checked="" type="checkbox"/> Checklist	Indicates a checklist of important operation or configuration sequences.
	Indicates that the instruction is only valid when a current transducer is connected to the controller.

SECTION 1:

CQ900 CONTROLLER OVERVIEW

Capacitor Bank Overview

The efficiency of transmission and distribution systems can be significantly improved by operating the system near unity power factor. This increases real power availability, reduces the overall load on the network and reduces system losses. As well as creating a better quality power supply, this reduces the overall costs related to transmitting power.

Installation of capacitors is the simplest and cheapest way of improving power factor. Capacitor banks supply kvar to the network at the point of connection reducing the burden on the rest of the electrical system. The advantage of using pole mount capacitor banks (as opposed to bulk substation compensation) is that they can be distributed throughout the network and mounted close to loads where they are needed most.

As the need for reactive power can fluctuate greatly depending on the load requirements at any point in time, modern utilities need the flexibility to switch their capacitor banks on or off-line. ABB's range of *CQ900 Capacitor Controllers* provide a low cost and reliable method of switching pole-mounted capacitors in and out of the network circuit to maintain the power factor as close to unity as possible.

The *CQ900* can be easily set-up, configured and monitored either through the large front panel LCD and keypad or by using the supplied PC software. The PC software allows the user to connect to the controller unit via USB cable to download data logs, make configuration changes, create and save configuration files as well as many other features.

CQ900R models have all the functionality of the CQ900L controllers as well as the ability to communicate and be controlled remotely over either a wireless or wired SCADA network using the DNP3.0 protocol.

Features

The *CQ900 Smart Controller* is a next generation automatic capacitor bank controller equipped with (but not confined to) the following features:

- **Advanced Control System** – Fast onboard micro-processor for accurate sampling, measurement and decision making. Flash upgradeable software allows new software features to be deployed in the field.
- **Easy To Use** - the *CQ900* includes a logical structured menu system and user-friendly navigation interface including 4-line LCD screen.
- **Universal Power Supply** – 90VAC to 264VAC without the need for different hardware.
- **Frequency Auto-Detection** – 47Hz to 63Hz real-time frequency measurement.
- **Fully User Programmable** – Either via unit faceplate or PC software for maximum flexibility in operation.
- **Electrical Protection** – 450V varistors and transient voltage suppressors provide fast spike and ESD protection (1500V 8/20 μ s impulse protection).
- **Wide Environmental Operating Conditions** - -40°C to +70°C (-40°F to +158°F)
- **IP65 Rated Enclosure** - lockable, weatherproof, robust, stainless steel casing with MIL-Spec screw connectors.
- **Flexible Mounting Options** - using a range of meter socket wirings, pole mounting with screws or metal strapping.
- **Real-Time Monitoring of Network Parameters** – including voltage, frequency, current, temperature and power levels. Voltage and current are measured using accurate “True RMS” calculations.
- **Advanced automatic switching** – Automatic switching decisions based on schedule, voltage, kvar, current or temperature, or a prioritised combination of any 3 of the above parameters.
- **Advanced Schedule Support** – Includes separate summer and winter schedules, individual schedules for work and non-work days, daylight-savings time support, holidays and a fully programmable working week.
- **Wide range of switch types supported** – Can operate motor driven, solenoid driven or electrically held switch types.
- **External temperature sensor** – measuring ambient air temperature.
- **CQ900 utility software supplied** – an MS Windows™ compatible software package for external configuration and data retrieval purposes.
- **Data logging** – automatic event driven logs (ie open and close signals, alarms) and user programmable time based logs recorded into non-volatile memory, allowing over 10,000 data logs.
- **CSV (Comma Separated Value) Data Log** – allows for data transportability into most spreadsheet programs (i.e. MS Excel, etc.)
- **Flash stored programmed settings** – maintains user settings regardless of power state.
- **Real time battery backed clock** – approx 10 year life (unpowered state)

- **USB2.0 communications interface** - via a standard USB PC interface and ABB CQ900 faceplate. Used for all software settings and data log downloading.
- **ISO-9001 manufacturing environment** - ensures a high quality product
- **Optional Available Features**
 - ABB CapLink short range wi-fi communications.
 - Neutral current measurement via sensor input.
 - Capacitor bank switch feedback monitoring

The **CQ900R** remote control enabled controller features all of the features of the CQ900L automatic capacitor controller as well as:

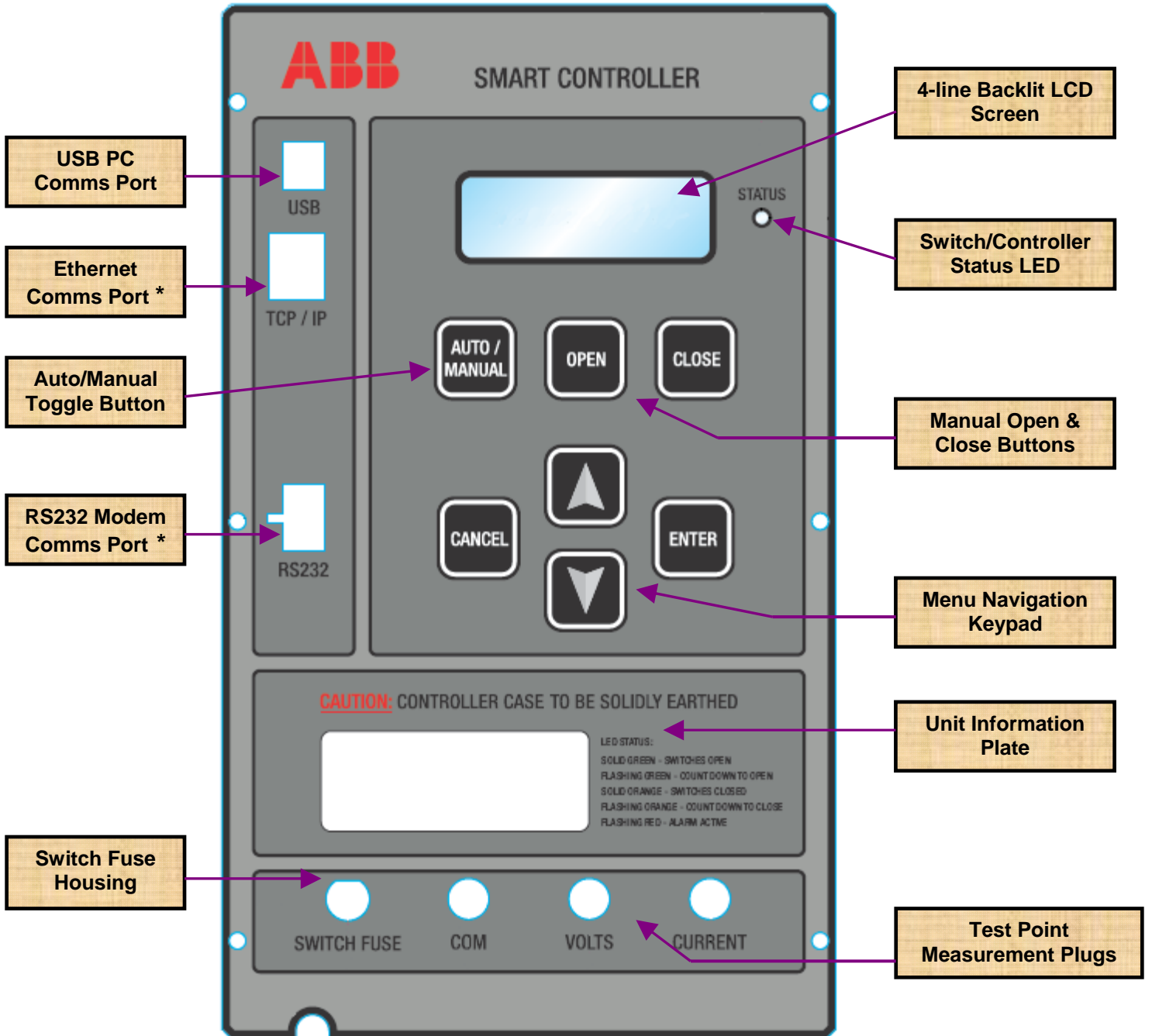

- **DNP3 remote comms** – Unit remotely controllable using a wide range of radio modem devices using DNP3 over serial connection.
- **12VDC power supply** – Auxiliary equipment (ie radio modem) powered from integrated power supply
- **Large mounting space for radio** – Extra deep door cavity and blanking plate supplied for mounting a wide range of radio devices inside the unit.

Front Panel View



Front Panel Features

Feature	Description
LCD screen	The 4-line backlit alphanumeric LCD screen displays real-time measurements, control information, and menu options. Status and alarm messages are also displayed depending on controller status
Switch / Controller Status LED	When power is applied to the controller (after power-up procedure), the tri-colour LED will illuminate and report the status of the switches: Solid Green – Last signal sent to switches was OPEN # Flashing Green – Unit is counting down to send open switches command Solid Orange – Last signal sent to switches was CLOSE # Flashing Orange – Unit is counting down to send close switches command Flashing Red – Hardware error alarm or problem with the controller (contact ABB representative)
AUTO/ MANUAL	Use this button to toggle the controller between automatic and manual mode. If the controller is in automatic mode, none of the other keys on the front panel are active.
OPEN	Manually open the switches.
CLOSE	Manually close the switches.
CANCEL	Use the CANCEL key to: <ul style="list-style-type: none"> • Escape from a screen without saving any changes • Exit from a menu • Cancel any pending switch operation.
	Use the arrow keys to scroll up and down: <ul style="list-style-type: none"> • Through menus • Through available options when a setting is required to be changed. • Increment & decrement setting values.
ENTER	Use the ENTER key to: <ul style="list-style-type: none"> • Enter into a menu or select an option. • To accept a value after selection.

Feature	Description
USB PC Communications Port	<p>USB2.0 communications port used to connect the unit to a PC. Supplied PC utility software allows monitoring, configuration of the CQ900 and data log retrieval.</p> <hr/> <p> Note: The controller must not be connected to the PC during the PC power-up or shutdown process. This may cause the unit's communication to be disabled. Power resetting on both the PC and the controller may be required to reset the fault.</p>
Unit Information Plate	<p>Contains information on the model number, serial number, fitted options and any other information relating to the particular unit.</p>
Switch Fuse	<p>Protects the output relays in case of a switch fault.</p> <ul style="list-style-type: none"> • 10A slow blow 3AWG (M205) fuse type.
Test Point Measurement Plugs	<p>The measured readings displayed on the CQ900 can be verified by a calibrated meter.</p> <ul style="list-style-type: none"> • To measure incoming VT secondary voltage, place insulated test probes into the COM (common) and VOLTS plugs • To measure the current (if a suitable current sensor is being used), place insulated test probes into the COM (common) and CURRENT plugs. The reading will be a voltage signal 0-10VAC to correspond with the output of the current sensor. <hr/> <p> Warning: Although safety banana plug type sockets are used, there is still the risk of shock if improper test probes are used. Depending on the VT used, voltages of approx 120VAC or 240VAC will be present at these measurement points</p>

- If no switch feedback is used, the controller assumes that the switches are not faulty (ie the switches are in the same state as the last controller instruction)

* - Only applicable in remote control CQ900R versions of the controller.

Configuring the Unit

Although the *CQ900 Smart Controller* can be configured either through the front panel keypad or by using the supplied *CQ900 Utility PC* software, it is recommended that the controller be configured via the *CQ900 Utility PC* software before being taken to the site of installation. There are additional functions available in the software such as alarm resetting and data log downloading that are not available via the faceplate.

Although both methods have a user-friendly interface that allows configuration of the *CQ900* with a minimum of effort, the PC option is useful for setting up multiple units, particularly with the same or similar configurations. The settings for one unit can be saved and then downloaded to as many other units as desired. Refer to *Chapter 3 – PC Utility Software Operation* for details of how to configure the unit using the utility software.

Configuring the unit via the faceplate is described in Chapter 3.

SECTION 2:

HARDWARE / SITE INSTALLATION (INCLUDING WIRING TABLES/DIAGRAMS)

 **Warning:** Personal injury or death may result unless correct safety procedures are followed at all times. When installing and commissioning the capacitor bank ensure that all the relevant electrical isolation and grounding practices are followed. In the event that any information presented in this manual contravenes standard safety procedures, the matter should be brought to the notice of the appropriate authority before proceeding.

Installation Checklist

The following checklist briefly describes the steps involved in installing the *CQ900L Smart Controller*. See below for detailed information about any of these steps.

1. Isolate power supply. It is assumed that no HV is connected at this point.
2. Ensure the **voltage transformer** (Refer to page 12) and **current sensor** (if used, Refer to page 12) are orientated and installed correctly
3. Remove the “Switch Fuse” located at the bottom left on the controller front panel.
4. Attach the controller to the pole (figures 2.1 and 2.2”)
5. Ensure that the controller earth lug located on the bottom surface of the enclosure, has been properly and solidly earthed.
6. Plug the pre-wired connector plug into the controller.
7. Energise power supply.
8. Observe controller for correct start-up sequence and ensure the LCD screen and switch state LED are illuminated.
9. Put the controller into **Manual Operation** and program the unit - if required. (Refer to “*Chapter 3, Unit Set-up and Operation*”).
10. Replace the “Switch Fuse” located at the bottom left on the controller front panel.
11. Ensure the switch type setting is correct (motor, solenoid or electrically held). Test the controller for correct operation.
12. Check all readings for expected levels (i.e. voltage, current, VAR, temp, etc.).
13. Return controller to “automatic mode” and close / lock the enclosure properly.

 **Warning:** It is critical that the unit is properly grounded.

Mounting the Controller (Standard Installation)

To mount the controller to a wooden pole, use suitable wood screws and the slots provided in the mounting bracket. Insert a minimum of 4 screws (one per slot) to ensure solid mounting. Refer to *Figure 2-1* for screw slot locations. It is advisable to use washers on each screw if the screw heads are smaller than the slot dimensions.

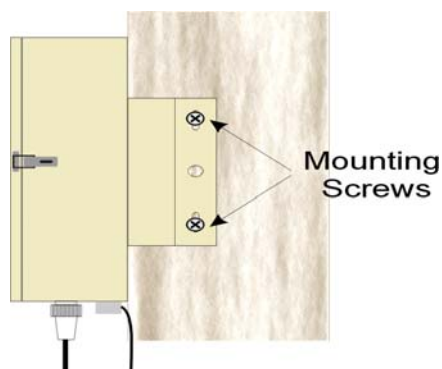

Figure 2.1 - Wooden Pole Mounting

To mount the controller to a concrete or steel pole, use metal strapping. The *CQ900L* bracket contains 2 sets of symmetrical slots. Feed the strapping through the 2 sets of slots (refer to *Figure 2-2*). Use a crimp and tool tension and join the metal straps. Other suitable strapping will also suffice as long as a solid mounting is achieved.

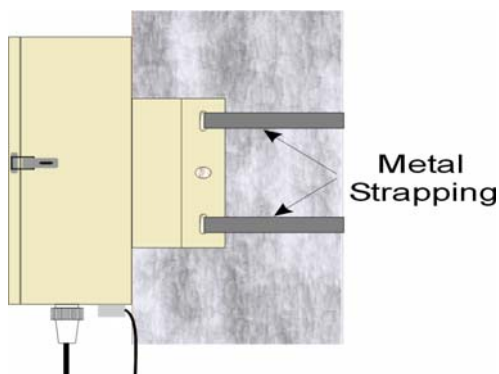

Figure 2.2 - Concrete Pole Mounting

Note: It is advisable to mount the unit a minimum of 3 metres (10 feet) above ground. This will minimise the chance of people tampering with the controller. This is only a recommendation however and is up to the discretion of the customer.

Mounting the Controller (Meter Socket Installation)

The CQ900L supports multiple meter socket wiring configurations. The correct configuration must be quoted at the time of ordering to ensure correct operation. The various wiring configurations can be found later in this manual. Standard meter socket installations use 6 blade meter sockets.

Warning: Ensure controller unit is solidly fixed to the meter socket with the retaining band adequately tightened before energizing the socket base. Do not energize meter base before installing the controller.

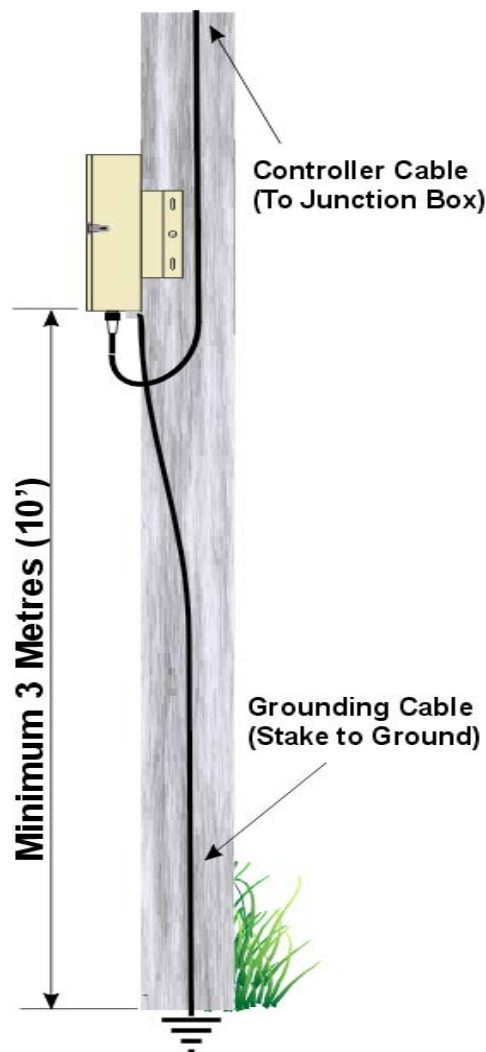

Figure 2.3 - Suggested Controller Pole Mounting

Grounding the Unit

It is important that the unit be adequately grounded to prevent the possibility of voltage being present on the enclosure and associated components. The preferred method for grounding is directly from the controller earth lug down to a ground stake at the base of the pole. If this method is not achievable then connection of the ground at a star point at the top of the pole or junction box will be suitable. Refer to figure 2.3.

Typical Polemount Capacitor Bank Installation

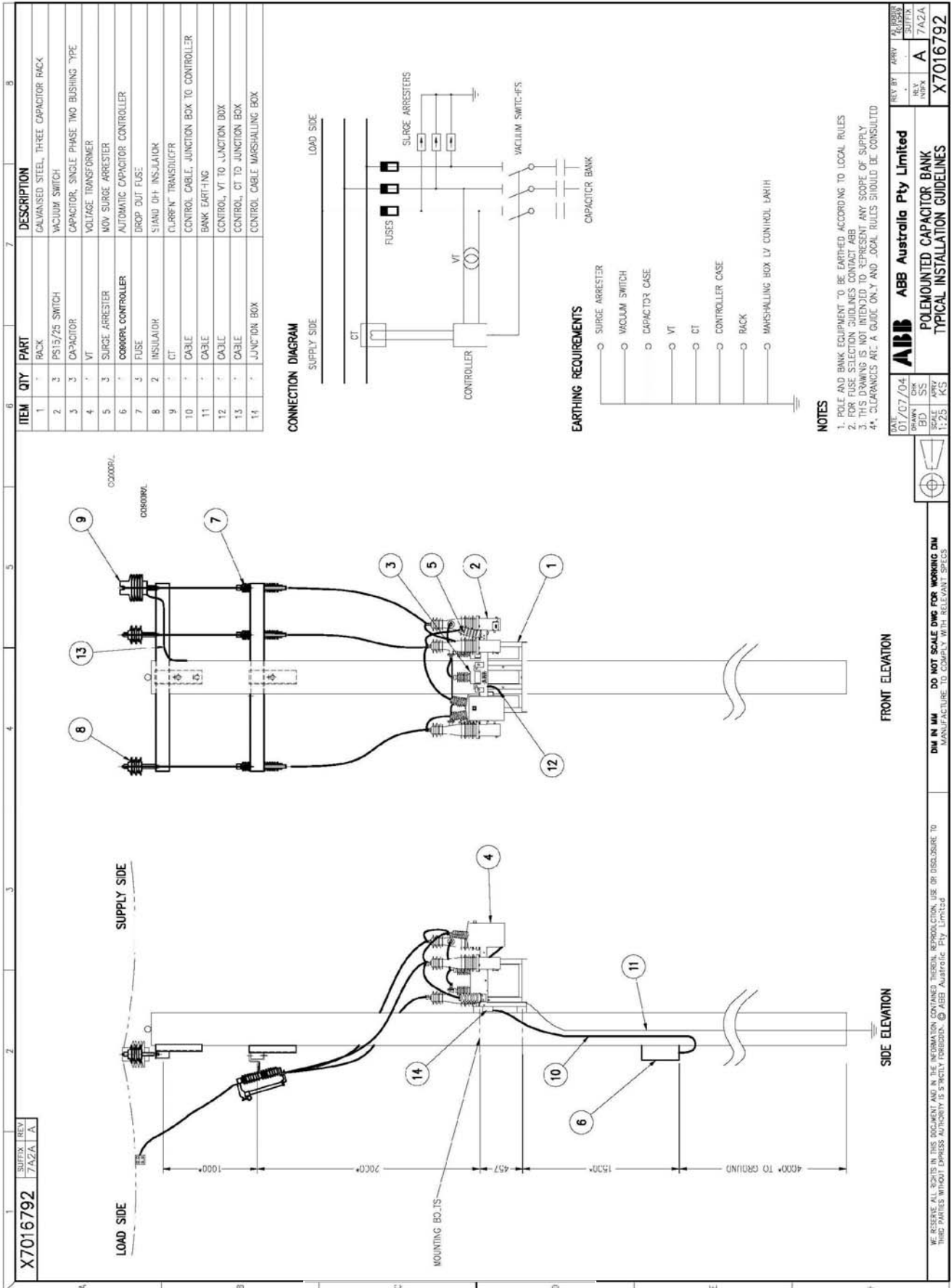

Figure 2.4

Configuration of the Voltage Transformer

The voltage transformer (VT) is used to both power the unit and allow for measurement of high voltage (HV) lines.

Check that the voltage transformer (VT) is sized appropriately and installed correctly. To power the CQ900 and actuate 3 ABB PS vacuum switches adequately, a minimum of 1.5kVA VT is recommended – smaller VT's may result in voltage drops to the controller and damage to the switches. Due to the wide range universal power supply built into the CQ900, a nominal secondary voltage of either 120VAC or 240VAC can be used.

Check to ascertain whether the VT is configured phase-to-phase or phase-to-neutral and the phase orientation is correct. The correct VT ratio will need to be programmed into the controller for correct voltage and power measurements to be calculated.

If the VT is connected *phase to neutral*, wire the current sensor on the same phase as the VT. (i.e. VT = Phase A → Neutral and Current Sensor on Phase A)

If the VT is connected *phase to phase*, wire the current sensor on the remaining third phase. (i.e. VT = Phase A → Phase B with Current Sensor on Phase C)

Configuration of the Current Sensor

For all measurements requiring a current input signal (ie Current, KVA, kvars, Power Factor) an appropriate **current sensor** (not current transformer) must be installed. The CQ900 is calibrated to utilise current sensors which convert a **0-600A line current to a 0-10VAC output signal**.

To ensure correct current readings are recorded, the current sensor (if used) should be located **upstream** of the capacitor bank. This will ensure the reduction in load provided by the capacitor bank will be correctly recorded.

It is important that the orientation of the current sensor is aligned with the normal flow of current to prevent reverse polarity current readings.

Careful consideration must be given to whether measurement of the network load or measuring kvar being supplied by the feeder is more important. To accurately measure both; and the effect the capacitor bank will have on each, requires that the current sensor is installed on different sides of the capacitor bank relative to the feeder.

- **Current based measurement / switching** – The current sensor should be connected LOAD side of the capacitor bank.
- **Kvar based measurement / switching** – The current sensor should be connected SOURCE side of the capacitor bank (as shown in figure 2.4)



Warning:

Reverse installation of the current sensor results in negative active power readings, and a reverse power alarm. To rectify this problem, reinstall the current sensor with the correct orientation.

Testing the Controller Operation

The following procedure/steps will quickly verify that the controller has been correctly installed and is ready for operation (Assuming the unit has been configured and set-up before connecting at site – if not refer to chapters 3 and 4 for configuration details)

- Connect the 7-pin Amphenol connector from the junction box into the base of the controller to power-up the unit.
- The backlit Liquid Crystal Display (LCD) will power-up and display the “ABB” graphic (approx 1 Sec), followed by the Controller Version and serial number (approx 1 Sec), and finally display the AUTO mode status screen.
- When the AUTO mode screen appears the unit will send a switch open command (to place the bank switches in a known state) and the status LED (seen to the right of the screen) will illuminate **green**.
- If an alarm is present and displayed on the screen, this could indicate that something has been installed incorrectly (most likely incorrect installation of current sensor or incorrect VT ratio / configuration selected)
- Press the **AUTO / MANUAL** button. This will change the mode from Automatic to Manual Mode. The LCD will briefly display “Controller Mode: Manual Operation” and then will display the current controller time and date. The controller menu is now accessible.

 **Note:** Menu controls are only available if the controller is in Manual Mode.

- Use the ▲ or ▼ buttons to navigate through the display options until the **System Configuration Menu** is reached. (As Displayed). Use both the ENTER and CANCEL buttons to verify that all buttons on the faceplate work as expected.

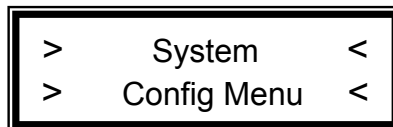

- For further information on navigating menus, refer to chapter 3

SECTION 3:

CQ900L UNIT SETUP AND BASIC OPERATION

Using the Front Panel (Automatic Mode)

Upon power up of the *CQ900L Controller*, it completes an initialisation process and then proceeds directly into **Automatic** mode. Whilst in **Automatic** mode the controller operates as has been previously defined in the user configuration settings.

Except for the **AUTO / MANUAL** button, all other front panel buttons (including **OPEN** and **CLOSE**) are disabled when in Auto mode. The **AUTO / MANUAL** control button allows the user to change the unit to **Manual** mode, where the controller settings may be altered.



Note: The controller must be in **Manual** mode before any change of settings can be made from the front panel.

While the unit is in Automatic mode, The LCD screen displays the following information (Figure 3.1):

Line 1 – Current controller mode

Line 2 – Switch State. Either open, closed or re-close block active. If re-close block is active the time remaining before the next close is also displayed

Line 3 – Status of any alarms present. If alarms are present the message will inform the operator how many alarms are present and then auto-scroll through the active alarms.

Line 4 – Display of core measured values. Measured figures for voltage, current, frequency and power factor will be displayed at 1 second intervals.

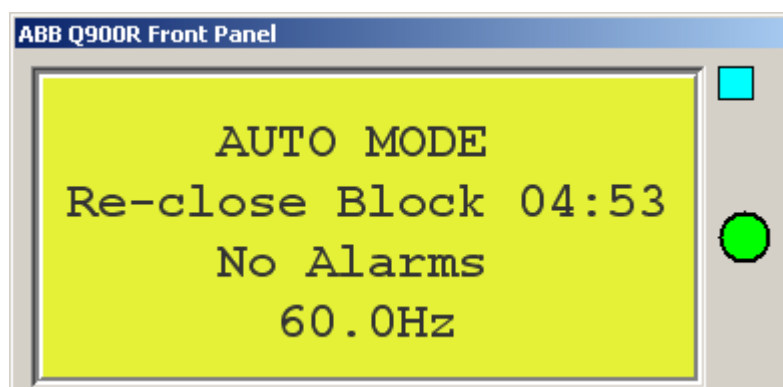

Figure 3.1 – Screen display in Auto mode

Using the Front Panel (Manual Mode)

Opening and Closing the Switches

Pressing **OPEN** when at any top level menu or display screen will send an open command to the switches, regardless of the actual status of the switch.

If the **CLOSE** button is pressed within the re-close block-out period, the **Re-Close Blocked** message and the re-close time remaining will display on the LCD, and the controller will not send the CLOSE command.

The *Re-close blocking function* is a safety feature that allows the capacitors to discharge before re-energization. The re-close blocking time delay is programmable to either 5 or 10 mins to allow for different capacitor standards in use. Once the delay period has expired, the **CLOSE** button must be pressed again to initiate the CLOSE operation.

- The following outlines the sequence of events that occurs when an OPEN command is sent:
 - ⇒ The status LED flashes green whilst the open operation is pending (regardless of what state the switches were previously in).
 - ⇒ The switches will open after the preset time delay set in the **Switch Open Delay** setting within the **Operation Config** menu. The switch delay countdown is displayed on the LCD screen.
 - ⇒ While switching is taking place a **Warning... Now Switching** message is displayed on the LCD screen.
 - ⇒ Upon completion of the open operation, the status LED will be lit steady **green**.
- The following outlines the sequence of events that occurs when a CLOSE command is sent.
 - ⇒ The status LED flashes orange whilst the close operation is pending (assuming re-close block is not active)
 - ⇒ The switches will close after the preset time delay set in the **Switch Close Delay** setting within the **Operation Config** menu. The switch delay countdown is displayed on the LCD screen.
 - ⇒ While switching is taking place a **Warning... Now Switching** message is displayed on the LCD screen.
 - ⇒ Upon completion of the close operation, the status LED will be lit steady **orange**.



Note:

A switching operation (CLOSE or OPEN) may be cancelled during the delay countdown period by pressing the **Cancel** key on the front panel keypad. This feature is only available when the controller is in **Manual Mode**

Navigating around the menus

Once in **Manual** mode, all the front panel keys become available. Use the navigation keypad to move through the menus, view settings and to change the value of settings.

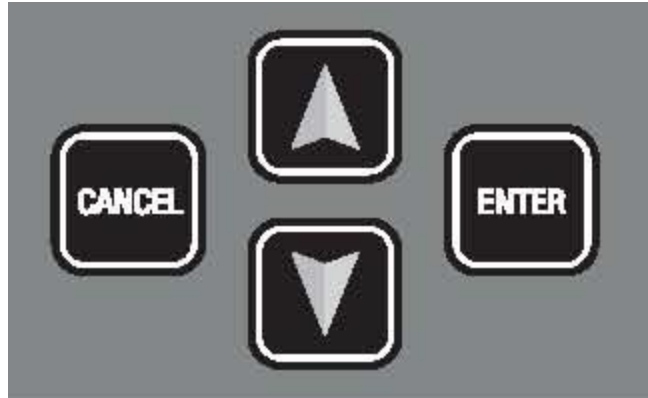

Press the ▲ key to navigate directly to the sub menu.

Press the ▼ key to cycle through all the status screens and view the current readings.



Note: Keys cannot be held to cycle through settings. Each press of a key, cycles to the next setting in the sequence.

Appendix A contains a diagram of the whole menu structure. This diagram will assist with viewing and locating the navigation paths available. Factory defaults are also defined.

There are three different types of LCD screen displays:

- Status and information displays.
- Menu screens.
- Configuration setting screens.

Status displays

A status display screen shows real-time network values, for example the external temperature, VT secondary voltage and power factor. These are for information purposes only and they are all displayed from the parent level of the **Manual** mode menu.

Menu screens

Menu (or Title) screens have arrows in each corner so that they can be quickly distinguished from other types of displays.



Press **ENTER** to enter into that menu.

- Within the menu, Press ▲ or ▼ to cycle through the options.
- Press **CANCEL** to exit from the menu.

Configuration setting screens

The configuration setting screens (found once entered into a menu area) allows changing of settings on the CQ900L.

On a configuration screen, the local settings are displayed. To change the setting:

1. Press **ENTER**.
2. Wait until the current setting flashes.
3. Press the ▲ or ▼ key to cycle through the list of possible options, or to increase / decrease the numerical value.
4. When the value required for selection is displayed, press **ENTER**.
5. The setting will be stored.
6. If there are no more settings to change it will return to the previous screen, otherwise the next setting flashes.
7. To discard the changed value and revert to the currently saved value, press **CANCEL** instead of **ENTER**.

Status displays

There are a number of real-time network and controller conditions that can be viewed on the LCD screen. These can be accessed by switching the controller to **Manual Mode** then using the up and down arrow buttons. The status displays include:

- **Time and date**
- **VT secondary voltage**
- **Line kVolts**
- **Line frequency**
- **Line current**
- **Line kWatts** (*Active Power*) **CURRENT SENSOR ENABLED**
- **Line kVA** (*Apparent Power*) **OPTIONS ONLY**
- **Line kVAr** (*Reactive Power*)
- **Power factor**
- **Neutral current** (if neutral current option enabled)
- **External temperature**
- **24 Hr operation count**
- **Total operation count**

A flow chart of the sequence of the display screens can be found in APPENDIX A: CQ900 controller menu flowcharts, diagram 1



Note: If the current sensor and/or the neutral current sensor are disabled, the items that require their input for display will not appear when scrolling through the status display screens. This prevents unnecessary information being displayed and prevents extraneous button strokes.

Using the menus

There are three menus available via the faceplate:

- **System Config** Menu.
- **Operation Config** Menu.
- **Schedule Config** Menu.

Options available for setting / viewing in the System Config menu

- **System Date and Time:** Date, day, month and year. Hours and minutes (24 hour clock format).
- **Temperature units type:** either Celsius or Fahrenheit
- **Switch Type:** motor, solenoid or electrically held operation (with varied switch times).
- **Limit Switch Feedback:** Enables or disables the use of switch status monitoring.
- **Limit Switch Polarity:** Normally open or normally closed auxiliaries are being used.
- **Feedback Checked Type:** Specifies whether the feedback utilises three separate switch inputs for individual switch monitoring, or a single input from commonly connected limit switch outputs (serialised or “daisy chain” arrangement).
- **VT Phase Configuration:** phase-to-neutral or phase-to-phase.
- **Voltage Transformer Primary Ratio:** values range between 3.3kV and 36kV
- **Voltage Transformer Secondary Ratio:** values range between 110V and 240V



Note Although the CQ900L controller has a universal power supply which allows operation at any voltage between 90VAC and 264VAC, the correct VT ratio and phase configuration must be selected to ensure proper measurement and calculations. Failure to do so will result in incorrect bank switching and alarm conditions.



Note: If a **Custom Transformer Ratio** has been selected within the *CQ900L Utility Software*, the above transformer ratios will not be available from the menu. The controller will display the custom ratio and disallow any modification.

- **Current Sensor Fitted:** Enables or disables current based measurements depending on whether a current sensor is installed
- **Neutral Current Sensor Fitted:** Enables or disables neutral current based measurements depending on whether a neutral current sensor is installed
- **Synchronise Switches:** synchronise open and closed switches.
- **Adjust LCD contrast:** increase / decrease screen contrast.
- **Adjust LCD brightness:** increase / decrease screen backlight brightness
- **Display Active Alarms:** displays the number of active alarms present and allows viewing of the alarms by using the arrow keys
- **Display History Alarms:** displays the number of alarms types experienced by the controller since the last reset and allows viewing of the alarms by using the arrow keys.

A flow chart of the sequence of the display screens within the System Config Menu can be found in APPENDIX A: *CQ900 controller menu flowcharts*, diagram 2

Options available for setting / viewing in the Operation Config menu

- **Data logging period:** Select either off (event logging only) or select the desired logging period – range from 30sec to 60mins
- **Switch close delay:** Sets switch close delay period (ie the time taken between the controllers decision to close the switches and the actual output signal) – range from 30sec to 10mins
- **Switch open delay:** Sets switch open delay period (ie the time taken between the controllers decision to open the switches and the actual output signal) – range from 5sec to 10mins.
- **Reclose blocking time:** Reclose block value can be set at either 5 minutes or 10 minutes depending on which standard the capacitors were built to.
- **Maximum operations (close operations) per day:** between 0 and 30. Operation counter resets at midnight each day
- **Operational mode:** auto / manual or fixed manual.
- **Auto Jump-Back Feature:** Enabled or Disabled. Sets whether the controller will revert back to auto mode at midnight if left in manual mode.
- **Reverse power action:** Determines what the controller does when the direction of the current on the feeder is reversed. Select between – Off (no action), close switches, open switches, or hold switch state
- **Auto-Switch priority one:** Selects the highest priority method of auto-switching the capacitor bank.
- **Auto-Switch priority two:** Selects the second priority method of auto-switching the capacitor bank.
- **Auto-Switch priority three:** Selects the lowest priority method of auto-switching

the capacitor bank.

- **Set Threshold Levels Menu:** Sets the threshold levels for the different auto switch settings. Threshold to set are:
 - **Voltage, temperature, kvar and current threshold periods.** This defines the time the threshold needs to be exceeded for before a switching signal is sent. Times range from 1sec to 15mins
 - **High and low voltage override set points.** Values depend on whether a 120V or 240V VT secondary is selected
 - **Extreme high, extreme low voltages set points.** Unit will ignore threshold periods and initiate a switching operation immediately if these values are exceeded.
 - **High and low winter and summer temperature override set points.** Allows different values for opening / closing temperatures depending on the season
 - **High and low kvar threshold values**
 - **Neutral current alarm and trip threshold values**
 - **High and low current threshold values**

A flow chart of the sequence of the display screens within the Operation Config Menu can be found in APPENDIX A: *CQ900 controller menu flowcharts*, diagram 3. See diagram 3a for a separate flowchart of the *Set Threshold Levels* Menu.

Options available for setting / viewing in the Schedule Config menu

- **Summer Start date:** Displays the programmed summer season start date (1st December as default). Pressing ENTER will activate the screen to either enable or disable the summer schedule.
- **Summer Open / Close times:** Sets the values for the 4 open and 4 close times per work and non-work day for the summer schedule. If the “Summer Start Date” is set to disabled, these screens will not be displayed.
- **Winter Start date:** Displays the programmed winter season start date (1st June as default). Pressing ENTER will activate the screen to either enable or disable the winter schedule.
- **Winter Open / Close times:** Sets the values for the 4 open and 4 close times per work and non-work day for the winter schedule. If the “Winter Start Date” is set to disabled, these screens will not be displayed



Note:

If a single schedule is required for the entire year, select either the winter or the summer schedule only to be activated. The controller will only follow the times programmed into the activated season regardless of the time of year.

- **Daylight Savings Start date:** Displays whether the daylight savings feature is enabled. Pressing ENTER will activate the screen to enable / disable the daylight savings start date

- **Daylight Savings End date:** Displays whether the daylight savings feature is enabled. Pressing ENTER will activate the screen to enable / disable the daylight savings end date
- **Week Structure:** Allows individual setting of each day of the week as either a work day or non-work day.
- **Count of Annual Holidays:** displays the number of *annual* holidays stored. Annual holidays do not have a year attached to them and assume the same date is a holiday every year.

Extra holidays can be added, modified or deleted by pressing enter on the “Count of Annual Holidays” screen and scrolling up or down to the required operation.

- **Count of Specific Holidays:** displays the number of *specific* holidays stored. Specific holidays have a year attached to them and assume the holiday will change every year. Dates for holidays in different years will need to be added explicitly.

Extra holidays can be added, modified or deleted by pressing enter on the “Count of Specific Holidays” screen and scrolling up or down to the required operation.



Note: A holiday is considered a scheduled non-work day regardless of which day it falls on, and will follow the pre-defined non-work day schedule.

General Operation and Function Information

Real-Time Clock/Calendar

Controller scheduling is undertaken via the use of an accurate real-time clock, which is continually synchronised to an accurate line frequency signal.

The clock and date is controlled via a clock/calendar device supporting proper calendar operation (including leap years). During active controller operation the clock/calendar is synchronised to a timing frequency taken from the mains line frequency. During a power-down situation the real-time clock maintains high accuracy using crystal locked timing and reliable battery backup circuitry.

Operational Mode

Available controller operational modes include **Auto/Manual Mode** and **Fixed Manual Mode**. **Auto/Manual Mode** is the default setting for the controller and allows full operation of all the controller features. Selecting the **Fixed Manual Mode** will disable the automatic operation of the controller.

Current Sensor Measurements

To prevent erroneous measurements and potential switching problems, the controller needs to know whether a current sensor has been fitted to the overhead conductors or not. With the current sensor installed and enabled, measurements for line current, kVA, kW, kvars and power factor can all be displayed. Default status is disabled, but can be enabled via the faceplate (System Config menu) or by the PC utility software.



Note: Each controller supplied by ABB has the current sensor disabled by default from the factory

Neutral Current Sensor Measurements

If the capacitor bank installed is connected in Wye (star) configuration, any failure of switches, capacitors or blown fuses will cause unbalance current to flow in the neutral conductor. The CQ900 can measure the amount of neutral current present by utilising a neutral current sensor or potential sensing device, depending on whether the bank is grounded or ungrounded.

There are two programmable values for Neutral Current Sensing: Alarm and Trip. The controller can be programmed to either monitor one or the other, or both.

Neutral Current Alarm: Enabled in the *System Config Menu*, if the neutral current alarm value is exceeded, the controller will log the value of the neutral current, activate the neutral current alarm and illuminate the Neutral current warning LED.

Neutral Current Trip: Enabled in the *System Config Menu*, if the neutral current trip value is exceeded, the controller will log the value of the neutral current, activate the neutral current trip alarm and illuminate the Neutral current warning LED. The controller will also initiate an open signal to trip the bank offline.

Once the capacitor bank has been tripped due to neutral current, the bank will remain locked out until reset. The controller can be reset through the unit faceplate, through the PC Utility Software or via the remote DNP3 access.

Auto Jump-back Feature

In the event a CQ900 is mistakenly left in manual mode, this feature will automatically reset the controller to automatic mode at midnight. This feature protects against the accidental leaving of the controller in manual mode after service or inspection.



Note: The Auto jump-back feature ceases to operate when the operational mode is set to "Fixed Manual Mode".

Reverse Power Action

Reverse power occurs when the direction of current flow is opposite to the normal operation case. This can occur when a circuit switch allows a power line to be fed from another feeder. When reverse power is present the value of kvar and current measured by the CQ900 will be incorrect and can cause incorrect switching operations.

In the presence of reverse power the controller can decide to do the following:

- Ignore the presence of reverse power and continue switching decisions based on the programmed auto-switch settings
- Hold the bank in the state it is currently in and allow no switching operations until reverse power is no longer present

- Open the switches to take the bank off-line
- Close the switches to bring the bank on-line

If the CQ900 senses Reverse Power upon power-up after a new installation, it would most likely indicate that the current sensor has been installed incorrectly (refer chapter 2 for correct installation instructions).

Data Logging Operation

A data log entry can occur due to one of two reasons i) an event occurs (e.g. switching, power up, alarm activates) **OR** ii) a user defined time log occurs.

In either of these cases a single line of data is captured and stored in the controller's non-volatile memory. Data contained in each of these logs is formatted as follows:

- Time/Date (Time & Date Stamp of log operation)
- ID number corresponding to the event type which caused the log (outlined in the header of the log file) Eg. Switch open / close, high voltage, reverse power
- VT primary voltage
- VT secondary voltage
- Current sensor values (as default only CS1 will return a value)
- Neutral current sensor value (CS3 by default)
- Power Factor
- System frequency
- Ambient temperature (absolute figure)
- Bit set indicating temperature is Fahrenheit (set) or Celsius (cleared)
- Bit set indicating the power factor is leading (set) or lagging (cleared)
- Whether the reverse power flag was set.
- The position of the switch output
- Whether a history alarm event was set.

Time logging can be disabled or enabled by the user with logs entries able to be taken at intervals ranging from every 30 seconds through to every hour. Event logging is not a user-controlled feature; all events will be logged regardless of whether time logging is specified. This ensures that the important operations of the controller can be viewed regardless of whether the user has enabled data logging.

Data logs are downloaded in the form of an Excel .csv file. This can be exported and the data manipulated as required. Data logs can only be downloaded using the PC utility software.

Alarm Status Auxiliary Output Operation

A potential free relay contact is provided which activates in the event of an alarm action occurring including:

- Power Up – During unit initialisation on power up, the alarm indicator is active. This may indicate unit failure via continual resetting and initialisation.
- Active Alarms – All and any of these alarms will cause the relay to activate.

- History Alarms – All and any of these alarms will cause the relay to activate.

Switching Rules & Restrictions

To prevent over switching and prolong the life of the capacitors, the controller employs a number of switching restrictions. These limitations include:

- **Maximum Daily Operations** – Limits the number of switch operations available in each 24-Hour period (00:00 to 23:59). This counter resets at the beginning of each day and ensures that excessive threshold switching will not occur. The number of Maximum Daily Operations can range from 1-30 Operations.
- **Re-Close Blocking Delay** – After every switch **OPEN** operation the controller blocks all **CLOSE** switch operations for a user selectable period of either 5 or 10 minutes to allow capacitors to discharge. During this period a countdown timer will appear on the LCD (in auto mode). If in manual mode, and a **CLOSE** signal is sent during the block-out period, the amount of time left until switching can resume will display on the screen
- The controller will allow multiple sequential **OPEN** operations to occur. This will allow for the possibility that if a switch does not open due to a fault, the user can try again to open the switch.
- To cancel a pending switch operation pressing **CANCEL** during the switch delay period will cause the operation to cease. To cancel a switch operation initiated whilst in automatic mode, press **CANCEL** followed by **AUTO/MANUAL** key within 5 seconds to prevent the switch operation recurring.

Switch Synchronisation

This feature is useful for the initialising of all switches after a new controller installation has been completed, or in a situation where a switch falls out of synchronisation due to a switching malfunction. Activating this function will close all switches and then immediately open all switches. This bi-directional switching ensures that all switches are aligned.

The controller will not perform this function until the re-close blocking delay has expired.

Auto-Switching Control Functions

There are 5 auto-switching parameters available on the CQ900L controller:

1. **Voltage.**
2. **VAR**
3. **Current**
4. **Temperature**
5. **Schedule**

Any combination of up to three of the above parameters can be used together at any one time. The CQ900 uses a fully programmable priority system whereby the highest priority switching method takes precedence over the others when it comes to an operating conflict.

Default mode for each auto switching option is *off*. At least one of the available modes will need to be selected before the controller will perform any automatic switching. If **schedule** is going to be used, it must be selected as the lowest priority.

Operation example:

Auto-switching Priority 1: Voltage

Auto-switching priority 2: Temperature

Auto-switching priority 3: Schedule

In the above example, thresholds need to be programmed for Voltage and Temperature, with at least one scheduled operation time.

As long as the measured voltage and temperature is between the upper and lower thresholds the controller will switch based on the programmed schedule. As soon as the temperature moves out of the neutral zone, the controller will either send an open or close signal to the switches regardless of the time of day. If the voltage then moves above or below one of the voltage threshold levels a switching operation will be initiated regardless of what the temperature is and what the schedule would dictate.

Further examples of switching operations can be found later in this chapter.

Switching Actions

Each auto-switch parameter initiates a different switching action. The following table depicts the switching action incurred when a threshold level is exceeded.

Override	Threshold Status	Switch Action	Reason.
Voltage	Within Tolerance	No Action	-
	Upper Limit Exceeded	Trip	Bring Capacitors offline to lower line voltage.
	Lower Limit Exceeded	Close	Bring Capacitors online to increase line voltage.
VAR	Within Tolerance	No Action	-
	Upper Limit Exceeded	Close	Bring Capacitors online to maintain close to unity power factor
	Lower Limit Exceeded	Trip	Bring Capacitors offline to maintain close to unity power factor.
Temperature	Within Tolerance	No Action	-
	Upper Limit Exceeded	Close	Bring Capacitors online to compensate for inductive loads created by air conditioners.
	Lower Limit Exceeded	Trip	Reactive compensation not required due to resistive nature of heaters.
Current	Within Tolerance	No Action	-
	Upper Limit Exceeded	Close	Bring Capacitors online to reduce load on the network lines
	Lower Limit Exceeded	Trip	Take Capacitors offline as network load is back within limits.
Schedule	-	Switching dependent on user defined Schedule configurations.	



Note: Not all Auto-Switch priorities need to be filled for correct operation. If only one type of switch control is required, simply select this option at auto-switch priority 1. Similarly utilising only 2 of the switch control methods (priority 1 and priority 2) is perfectly acceptable.

Schedule Switching Control

Schedule based switching is most common when the demands on the network follow regular time intervals or there are clearly established daily load profiles. A combination of schedule switching with voltage, VAR, current or temperature control to cover unexpected variations allow for very good network control.

Separate daily schedules can be programmed for both work and non-work days, as well as for summer and winter seasons.

Week Structure

A fully programmable working week structure can be set to cater for regions around the world. Each day can either be classified a **work day** or **non-work day** with each day type allowing different switching schedules to suit the different loading.

Seasonal Structure

The CQ900 allows two seasonal schedule variations; **Winter** and **Summer**. Each season can have a completely different switching schedule to the other.

Although these schedules are primarily configured for seasonal scheduling, they can be of different lengths in months (i.e. Winter Schedule = 10 months; Summer Schedule = 2 months). The length of the “season” is controlled by setting the start date of each (no end date)

Work day / Non-work day Switch Schedules

Use of all available time slots is not required and any times left blank (or disabled via the faceplate) will not result in an operation. Schedule times are required to be entered in **24-Hour Time Format** (i.e. 00:00 → 23:59).

Close and Open times may be entered in any order as the controller will automatically re-order the times for correct schedule operation.

Daylight Savings Operation

If enabled, *Daylight Savings* start and finish dates can be programmed in the CQ900. At midnight of the start of the first day of daylight savings the CQ900 clock will move the time forward by one hour, with the time moving back by one hour at midnight of the finish date. Scheduled open / close times are automatically compensated to maintain correct switch operation.

Built-in software flags prevent an error loop occurring when time is shifted back of forward due to daylight saving operation.

Holiday Schedule

Up to 30 user-programmed holidays are available and can be entered in terms of an

annual repeating holiday (i.e. New Years Day - 1st Jan) or in term of a specific day which changes date every year (i.e. First Tuesday in November).

When the holiday schedule has been enabled and the present day/date has been specified as a holiday, the controller will automatically operate according to the non-work day schedule.



Note: If Schedule switching is selected along with other auto switching control methods, **it must be selected as priority 3**. Given the schedule dictates a time of day for the switches to be in a certain state, any lower level priorities will always be ignored for a given time.

Voltage Switching Control

High & Low Voltage Thresholds and **Extreme High & Low Voltage Thresholds** provide the user with the ability to perform accurate voltage switching. Voltage control is a popular control method when voltage regulation is a primary consideration in particular when Conservation Voltage Reduction (CVR) is being practiced.

Assuming var and current measurement are not required, using voltage based switching also removes the need to install a current sensor on the bank.

Voltage Thresholds:

- The “**Extreme Low Voltage Threshold**” may not be set higher than the “**Low Voltage Threshold**”. Similarly, the “**Extreme High Voltage Threshold**” may not be set lower than the “**High Voltage Threshold**”.
- There must be a minimum bandwidth separation between an **Extreme Threshold** and an **Override threshold** of 5 Volts.
- There must be a minimum bandwidth separation between the **Low Threshold** and the **High Threshold** of 5 Volts.

The below table shows the setting limits for thresholds and band width separation.

Voltage Threshold Boundary Limits	120V Nominal	240V Nominal
High Voltage Override Threshold Maximum Limit	155v	265v
Low Voltage Override Threshold Minimum Limit	85v	195v
Extreme High Voltage Threshold Maximum Limit	160v	270v
Extreme Low Voltage Threshold Minimum Limit	80v	190v
Minimum High & Low Voltage Override Threshold Separation	5v	5v
Minimum Extreme & Voltage Override Threshold Separation	5v	5v

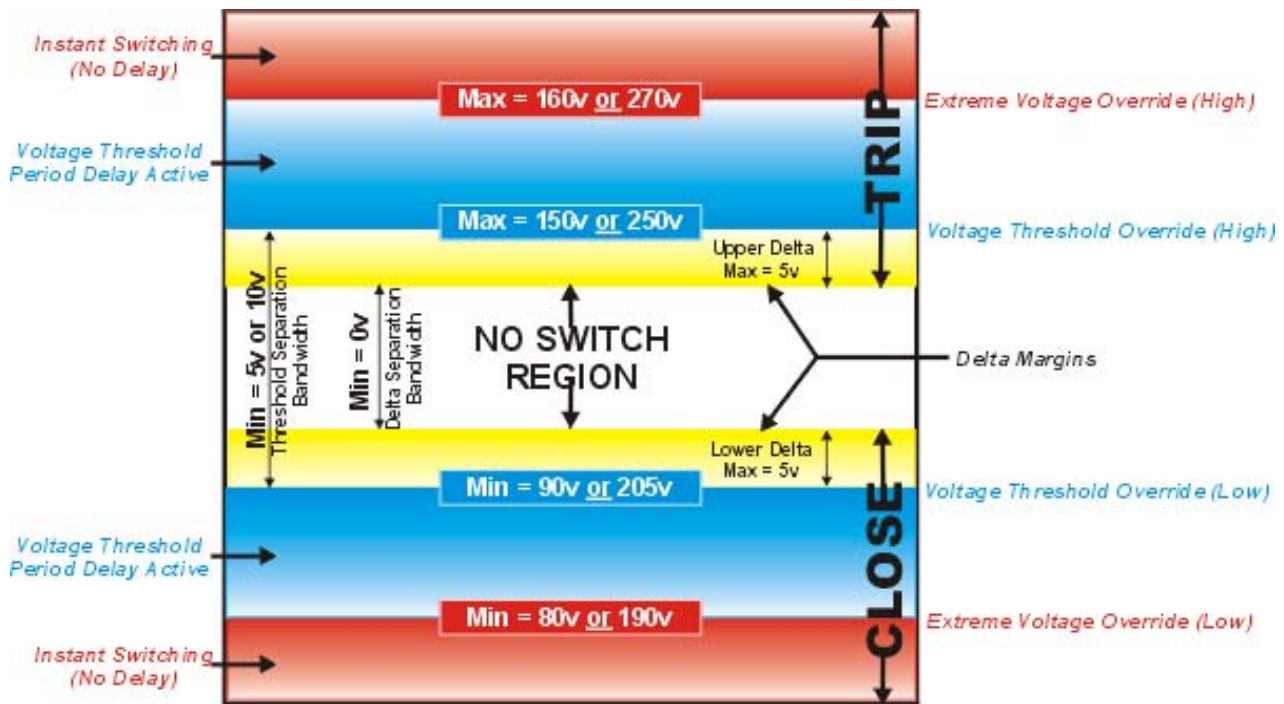

Figure 3.2 – Voltage Only Threshold Map

Operation of the “Voltage Only” switching mode consists of four main regions:

Non-Switching Region (Figure 3.2 - White Region) is the area bounded by the high and low voltage override thresholds. Whilst the voltage remains within this region no switching occurs, whether the switch is currently closed or open it will continue to remain in that state. Generally the nominal controller voltage (i.e. 120v or 240v) is located within this region.

Delta Margins (Figure 3.2 – Yellow Regions). Each time a switching operation occurs, the voltage is measured just before switching and then again 3 seconds after switching, the difference between the two is known as the *Delta* value. Delta margins are automatically calculated and adjusted after each switching operation to ensure that the voltage change due to the capacitor bank going on / off line does not cause switch hunting or bank cycling.

This feature is not required to be set-up or controlled by the user, it will always operate when *voltage switching control* is used. Delta is added to the Low Threshold and subtracted from the Upper Threshold.

High and Low Voltage Regions (Figure 3.2 - Blue Regions). As voltage levels infringe into either of these regions a period timer begins a countdown from the specified “Voltage Override Period” to zero. During this count down if the voltage alters back to an acceptable level (within thresholds) the timer resets. However, if the voltage level remains over threshold an appropriate switching operation occurs (note: switching operation delay may include the safety delay time of 5 or 10 minutes).

Extreme High and Low Voltage Regions (Figure 3.2 - Red Regions). If the voltage moves into the “Extreme Threshold” region, switching operation begins immediately and ignores the standard switch open / close threshold period – however switch open and close delay times still apply. If the voltage crosses back into the acceptable region during the open / close delay periods, the operation will not be reset.

Operational Example (Voltage Only)

For familiarisation with operation of the “Voltage Only” mode, a switching model example has been supplied below in figure 3.3.

Initially the voltage level exceeds the “Voltage Override High Threshold” (Blue Line). The threshold timer counts down the user chosen period of 2 minutes before activating the switching operation, and then waits a further 30 seconds for the switching delay to expire before the switch operation occurs. Notice the effect of the drop in voltage after the switch occurs on the delta level and how it adjusts its level to account for this change (Yellow Line).

The second event demonstrates the voltage level first exceeding the “Voltage Override Low Threshold” (Blue Line) and then continuing to drop below the “Extreme Low Voltage Threshold” (Red Line). On crossing the Blue Line the threshold period timer starts timing the period for which the voltage exceeds the threshold. On crossing the Red Line the timer is reset and the switching operation activates immediately. After the safety switching delay (30 Secs) the operation occurs. Once again the voltage change between before and after switching adjusts the delta level.

The third and final event demonstrates an initiated, but cancelled switching operation. As with the first event the voltage exceeds the “Voltage Override High Threshold” and the threshold period timer begins. This time however the voltage drops back below the threshold during the timer period cancelling the switching operation and resetting the threshold timer. If the voltage level were to jump back and forth across the threshold level, then the timer would reset continually (with no switch operation) until the measured voltage exceeded the threshold level for the entire duration of the timer.

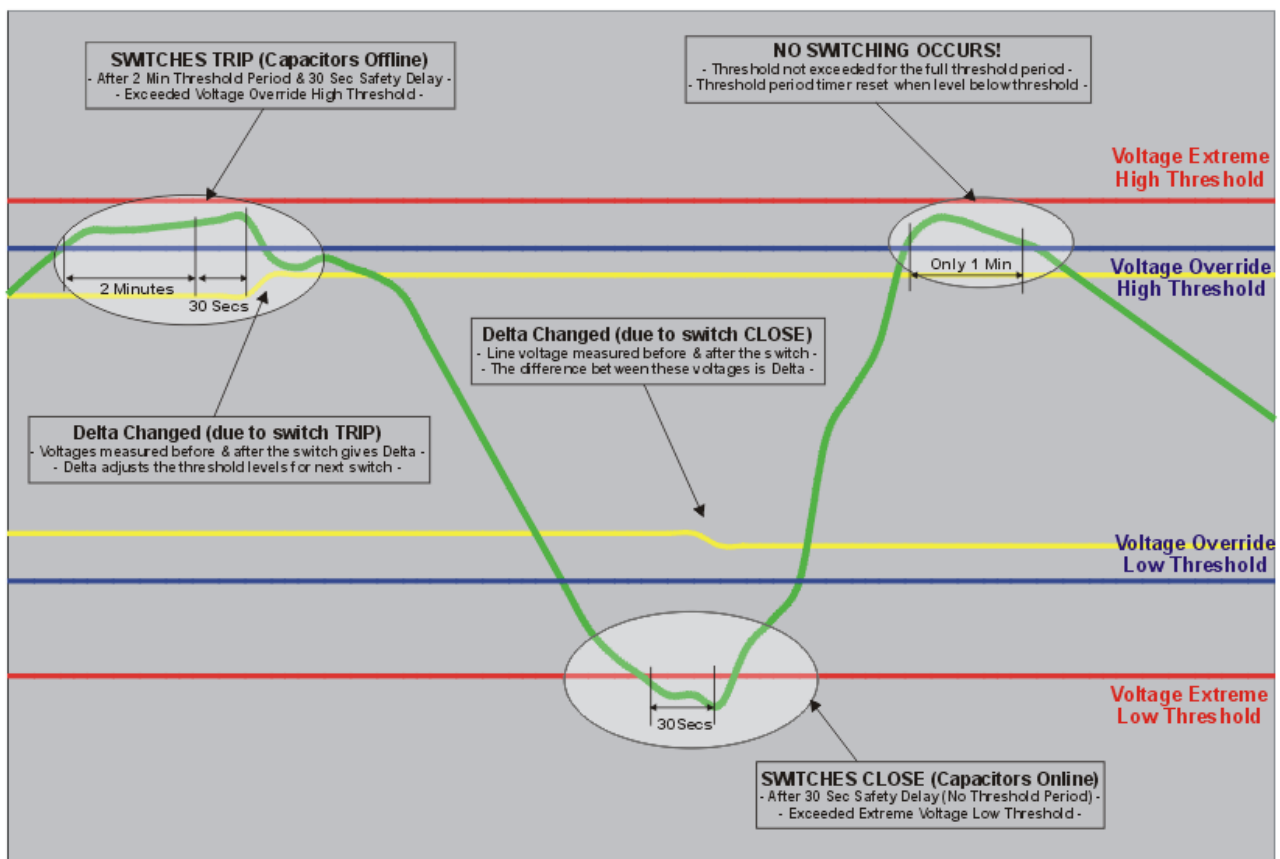

Figure 3.3 – Voltage Switching Example Model

“Voltage Only” Important Notes

1. Once the unit begins counting down the switching delay, the switching operation will occur unless a user manually overrides it by pressing the ESC button on the front panel keypad.

Temperature Switching Control

Temperature based switching is a viable option when the user knows the relationship between ambient temperature and network demand. Air-conditioning units in particular are large consumers of reactive power, making the correlation between temperature and reactive power demand clear. The CQ900 supports separate summer and winter temperature switching ranges to allow for seasonal temperature variations.

Assuming var and current measurement are not required, using voltage based switching also removes the need to install a current sensor on the bank.

Temperature Thresholds

- Minimum temperature separation levels between the High and Low Override Thresholds are **6°F** and **3°C** respectively. This separation allows for fluctuations in temperature measurement thereby reducing the chance of switch hunting (Figure 3.4).
- Temperature Threshold High maximum value = **122°F / 50°C**. Temperature Threshold Low minimum value = **- 40 °F / - 40°C**.



Note: Threshold limits and minimum separation values apply to both summer and winter temperature settings

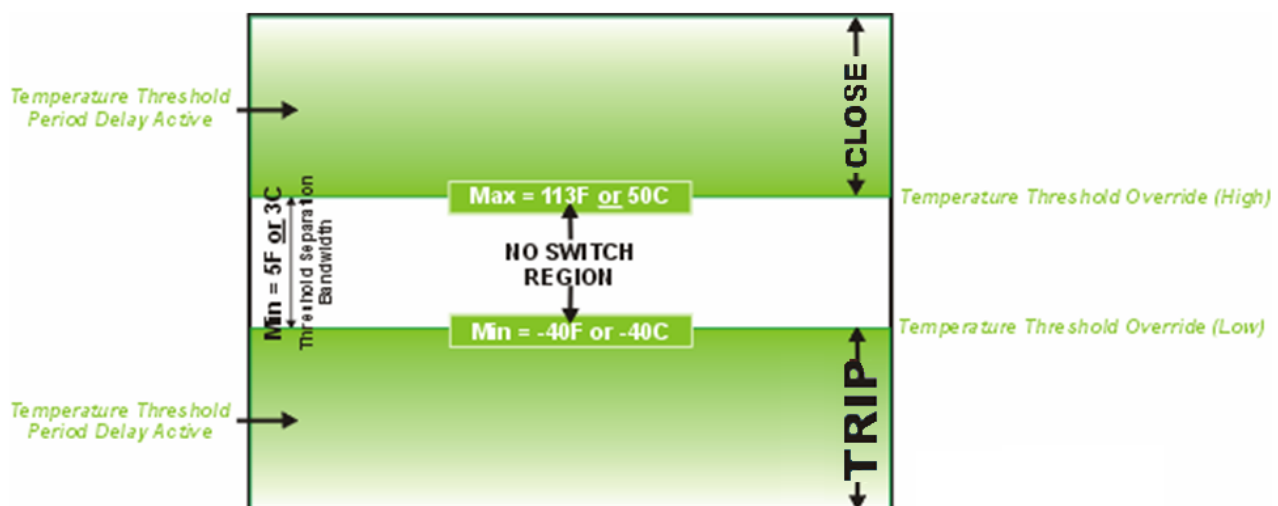

Figure 3.4 – Temperature Only Threshold Map

Operational Example (Temp Only)

Figure 3.5 below demonstrates two common events that may occur when “Temperature Only” mode is utilised. Firstly, on the left hand side of the diagram, the switch performs a close operation after a period exceeding the threshold. To the right of the diagram are three shorter breaches of the threshold, which do not result in a switching operation.

The first of the events demonstrates the temperature gradually creeping up until it crosses through the “Override High Threshold” value and into the threshold exceeded region. Upon crossing the threshold, the threshold period timer begins counting down from the user set “Temperature Threshold Period” value (10 minutes in this case) to zero. As the temperature remains above the threshold for the entire threshold period, the switch operation begins. After a 30 seconds safety delay the switches close.

As the temperature gradually reduces it crosses back into the neutral region where no switch operations will occur until another threshold is crossed.

Second of the events is a number of small threshold breaches, none of which result in a switch operation. These three events all cross over the threshold and back into the Non-Switch region before the temperature threshold period expires (ie 10 minutes). In this example the counter is reset each time without triggering a switch operation.

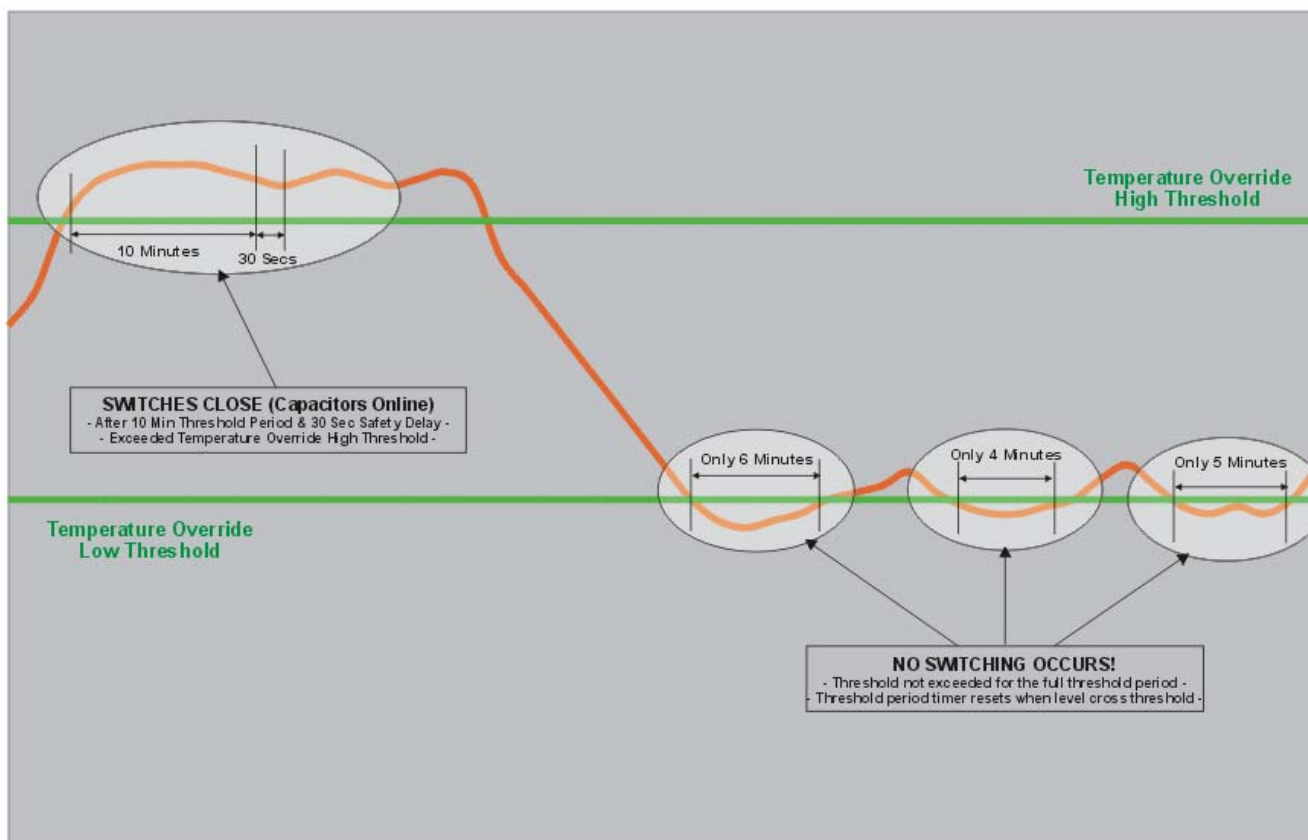

Figure 3.5 – Temperature Switching Example Model

“Temperature Only” Important Notes

1. The Temperature Threshold Period should be large in value (10 → 15 minutes). This allows the temperature to stabilise in the “Threshold Exceeded” region before switching commences, reducing unwanted switch hunting.

Var Switching Control

Var based switching combines the goals of loss reduction, power factor correction and reactive power compensation in the one control mode. Utilising the real-time input from the installed VT and current sensor, the CQ900 calculates the reactive power of the feeder line, bringing the capacitor bank on or off line as demand requires.

Var Thresholds

- The **kvar Low Threshold** cannot be set higher than the **kvar High Threshold**
- Minimum bandwidth separations between the **High and Low VAR Threshold limits** must be maintained.

kVAR Threshold Boundary Limits	120V Nominal (kVAR)	240V Nominal (kVAR)
High kVAR Threshold Maximum Limit	10000	10000
Low kVAR Threshold Maximum Limit	0	0
High kVAR Threshold Minimum Limit	0	0
Low kVAR Threshold Minimum Limit	-10000	-10000
Minimum High & Low Threshold Separation	50	100

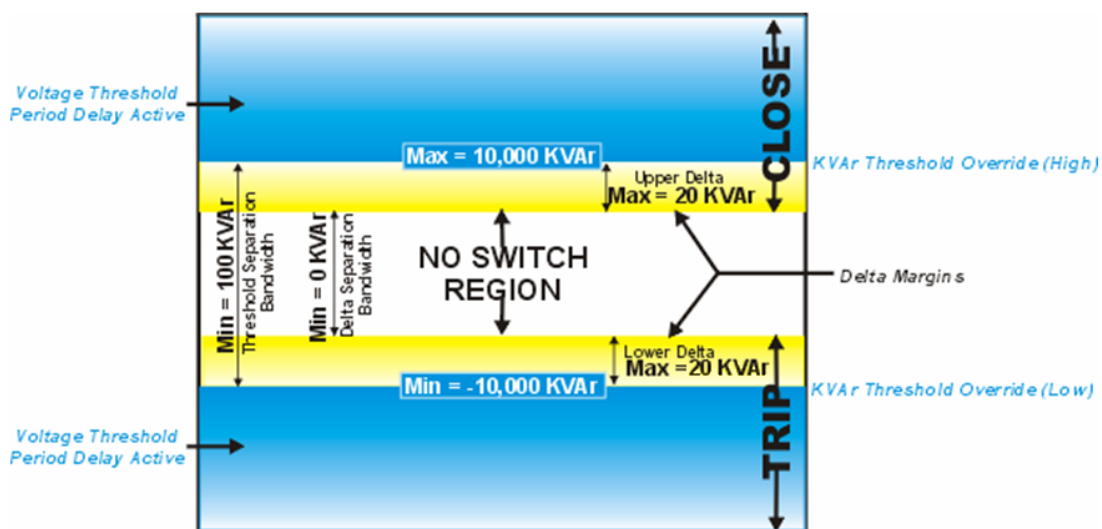

Figure 3.6 – VAR Only Threshold Map

Operation of the “VAR Only” switching mode consists of three main regions:

Non-Switching Region (Figure 3.6 - White Region) is the area bounded by the high and low kvar override thresholds. Whilst the kvar's remain within this region no switching occurs, whether the switch is currently closed or open.

Delta Margins (Figure 3.6 – Yellow Regions)

Each time a switching operation occurs, the kvar's are measured just before switching and then again 3 seconds after switching, the difference between the two is known as the *Delta* value. Delta margins are automatically calculated and adjusted after each switching operation to ensure that the kvar change due to the capacitor bank going on / off line does not cause switch hunting or bank cycling.

This feature is not required to be set-up or controlled by the user, it will always operate when *kvar switching control* is used. Delta is added to the Low Threshold and subtracted from the Upper Threshold

VAR Switching Threshold Regions (Figure 3.6 - Blue Regions) are bounded by the “High & Low kvar Switching Thresholds” As the kvar level infringes into either of these regions a period timer begins a countdown from the specified “var Override Period” to zero. During this count down if the voltage reverts back to an acceptable level (within thresholds) the timer resets. However, if the kvar remains over the threshold an appropriate switching operation occurs (note: switching operation delay may include the safety delay time of 5 minutes).

Application notes for var control switching:

- The size of the capacitor bank that is being controlled by the CQ900 will determine what appropriate open / close set points are. A general rule of thumb is:
 - Close set point: $2/3 \times$ capacitor bank size (kvar)
 - Open set point: Close set point – $(1.25 \times$ bank size)
- As outlined in the *hardware installation* instructions, when using kvar based switching the current sensor must be installed upstream (source side) of the capacitor bank.
- Using kvar based switching and current based switching requires the current sensor to be mounted on different sides of the capacitor bank. As a result only one of two options should be chosen when using multiple auto-switching control functions.

Current Switching Control

Current based switching looks more at the actual load on the network rather than kvar. This may be particularly useful when the majority of the network has resistive rather than inductive loads (ie cold climate areas). Secondary benefits of increased power factor and loss reduction will also be seen. Current based switching utilises the real-time input from the installed current sensor to bring the capacitor bank on or off line as demand requires

Current Thresholds

- The **Current Min Threshold** cannot be set higher than the **Current Max Threshold**
- Minimum bandwidth separation of 10A between the **High and Low Current Threshold limits** must be maintained

From an operational point of view please refer to the figure 3.6 – Var switching, as the basis for how current switching operates.

Application notes for Current control switching:

- As outlined in the *hardware installation* instructions, when using current based switching the current sensor must be installed downstream (load side) of the capacitor bank.
- Using current based switching and kvar based switching requires the current sensor to be mounted on different sides of the capacitor bank. As a result only one of two options should be chosen when using multiple auto-switching control functions.

Combination Auto Switch Settings

Given any three of the previously mentioned auto-switching modes may be activated at any one time, there are many possible auto switching mode combinations. Examples of this are “Schedule with Voltage Override” and “Temperature with var and voltage override”. The priority of the switching decisions is fully user programmable (ignoring conflicting combinations)

The operation of two such control modes is shown in the following examples:

Example 1: Schedule with voltage override

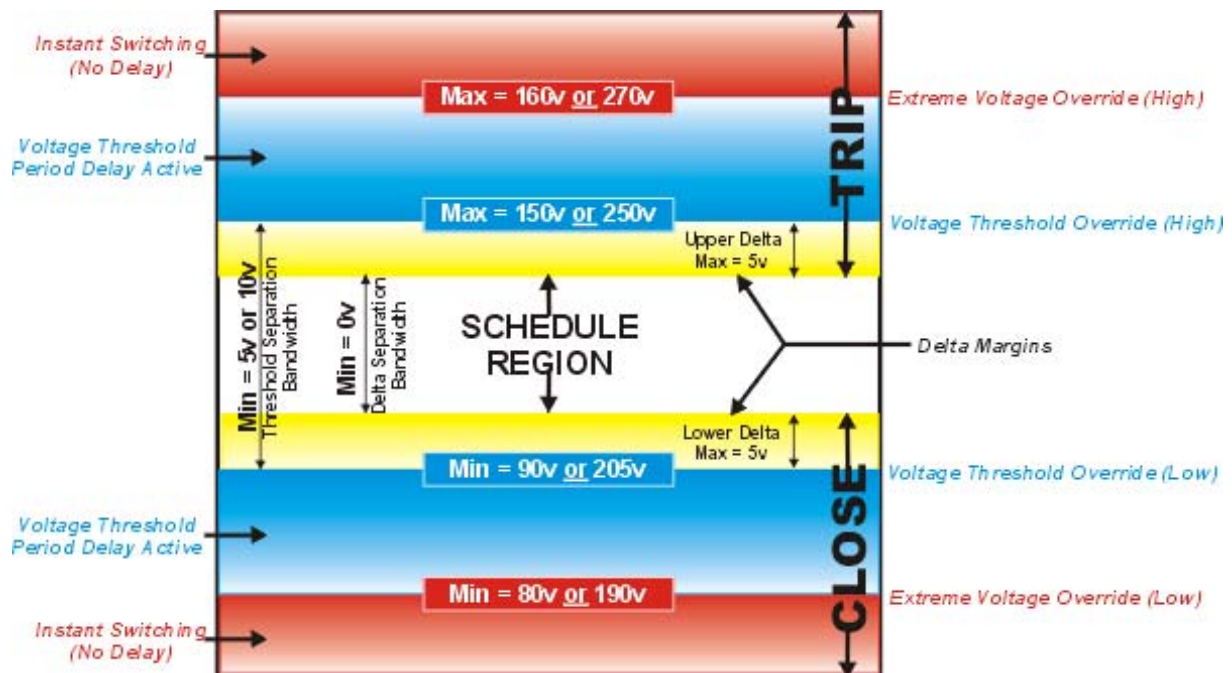

Figure 3.7 – Schedule with Voltage Override Threshold Map

In this example only two auto-switch priorities are being used: Priority 1 = voltage, priority 2 = schedule. The schedule with voltage override mode consists of four main components, two of which differ in operation from the “Voltage Only” mode. The controller will follow the times programmed into the schedule parameters, unless they conflict with the voltage override values.

Schedule Region (Figure 3.7 - White Region) is the area bounded by the high and low voltage override thresholds. When the voltage is in this region the switching follows the user-defined schedule.

Delta Margins (Figure 3.7 – Yellow Region) affect the area over which the schedule operates. Delta margins adjust the schedule region by moving the low and high threshold by the value measured on the previous switch.

Example 2: Schedule with temperature and voltage override.

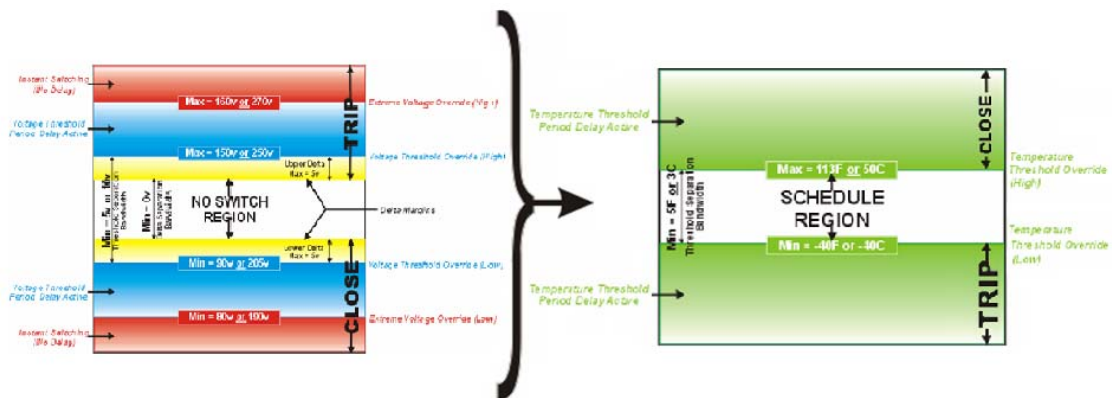

Figure 3.8 – Schedule with Temperature and Voltage Override Threshold Map

In the above example all 3 auto-switch priorities are being used: priority 1 = Voltage, priority 2 = temperature, priority 3 = schedule. According to the order of priority, the Voltage Override takes precedence over the Temperature Override and then finally the scheduled operation. The switches will only OPEN and CLOSE according to the schedule when the Voltage and Temperature are within the thresholds.

The other auto switching combinations follow the same logic as displayed above.

Controller Alarms

Active Alarm Descriptions

Active Alarms indicate alarm situations that are **currently** present within the controller. If an “Active Alarm” is triggered due to some condition, once the condition is no longer present, the controller will give no indication that an alarm has occurred. Active alarms record no alarm history, as only the immediate status is important to the user.

If there is a current alarm present, the LED light on the front face plate will flash red to alert the user.

History Alarm Descriptions

History Alarms indicate that an alarm situation has occurred at some stage during normal operation yet is not necessarily still active. It is possible for an alarm to trigger both an active or history alarm event.

When in **Auto mode**, the 3rd line of the LCD display shows the status of any controller alarms. If no alarms (current or history) are present, the screen will display “**No Alarms**”. If there are alarms present the screen will display which alarm is present, and if more than one alarm is active, the display will rotate through the alarms showing each for 1 second before showing the next.

When in **Manual mode**, the alarms are only visible when in the *alarms* menu screen (found under the **System Config Menu**). Here you will be able to scroll through the various active and history alarms present.



Note: The History Alarms register can only be cleared using the PC service software. Current alarms are cleared as soon as the alarm condition is no longer present.

CQ900 Controller Alarm Listing

The following alarms describe undesirable operating conditions or situations within the network. They are predominantly for information purposes and do not normally represent issues with the unit or bank installation.

- Extreme Voltage High / Extreme Voltage Low exceeded
- Max daily operations reached
- Reverse power present
- Switch fuse blown
- Switch Feedback Error

The following alarms describe system alarms indicating a potential problem with the CQ900 or capacitor bank hardware. If these alarms persist after system check and power cycle, please contact ABB.

- Voltage sensor fail
- Current sensor fail
- Temperature sensor out of range
- Frequency out of range
- RTC fail
- Dataflash fail
- Configuration item corrupt

☑ Checklist for configuring a new unit

Before installation of the CQ900L onto the pole, the following options should be set up or reviewed:

1. Time and date.
2. Temperature measurement type
3. VT wiring configuration.
4. Transformer ratio.
5. Switch type.
6. Switch close delay.
7. Switch open delay.
8. Maximum operations per day.
9. Enable or Disable the current sensor
10. Set the reverse power action (if current sensor is used).
11. Operational mode.(ie auto/manual or fixed manual mode)
12. If any auto-switching is required (ie kvar, voltage or schedule based switching)

Optional settings

Also consider whether to change any of the following settings:

1. Time based data logging period.
2. Schedule for the switching operation.
3. Relevant threshold levels for the switching operation.
4. Whether the faceplate keypad should be locked out or not.
5. The various thresholds for the auto-switching modes.
6. Whether switch feedback will be utilised.

SECTION 4:

PC UTILITY SOFTWARE OPERATION

The ABB CQ900 PC Utility Software is provided free of charge to customers when they purchase a CQ900 controller unit. It is a simple to use tab based application that users can operate with minimal instruction.

Although the CQ900 can have most of its functions programmed through the unit's touchpad interface, using the PC Utility Software to program units has several advantages:

- Additional features such as downloading data log files can be completed.
- Time taken to set-up units is drastically reduced.
- Configuration files can be saved and then used to set-up large quantities of units without the need to re-populate the software fields
- Menu items are separated into logical tabs allowing the user to view many parameters at once
- The CQ900 can be monitored and programmed while it is installed on the pole and the user is on the ground.

The PC Utility software can be run without the CQ900 being connected to the PC / laptop. This allows the user to become familiar with the various software tabs, as well as allowing configuration files to be set up and saved without having a controller present.



Note: It is recommended that the USB connector cable be connected from the CQ900 controller to the PC before the PC Utility Software is run.

Minimum hardware and software requirements

Requirement	Minimum
Computer type	IBM compatible type.
Operating system	Windows XP or later
Disk space required	5MB
Comm ports	Minimum of 1 USB2.0 serial port required
Cables required	1 x USB type A – USB type B cable (see figure 4.1)



Figure 4.1 – USB plug type A (left), USB plug type B (right)

Installing the Software

The PC Utility Software consists of a single executable (.exe) file that can be started from any location without the need to be installed on the host computer. This allows the software to be saved on a portable device and taken from computer to computer as required. This also removes any requirement for user administrator privileges on the PC/laptop being operated.

Once the PC Utility software file has been stored in a location of choice, double-click or press enter with the file selected to run the program.

Software compatibility

While every effort is made to make all newer versions of the PC Utility Software compatible with all versions of CQ900 unit embedded control software, it is recommended that the version of PC Utility software supplied with the unit be used for all programming and communications.

Software Start-up and Levels of Access

Upon opening the software, an introduction password control window will pop up (figure 4.2). There are two different levels of user access built into the PC Utility Software: **Monitor** and **Control**.

Monitor level access:

- Real-time measured values can be viewed
- Program settings can be viewed and compared
- Data log can be downloaded

Control Level access:

- Real-time measured values can be viewed
- Operational parameters and settings can be programmed / changed
- Controller can be manually switched without touching the unit keypad
- Alarms, data log and operation information can be cleared / reset.
- Voltage calibration and auxiliary relay operation can be verified.

To access either **Monitor** or **Control** mode within the software requires a different password to be input at the program start-up. To access monitor mode requires the password “**monitor**” to be entered into the text box, or simply pressing the **DONE** button will have the same effect. To enter into the control mode access level, the password required is “**control**”. If the incorrect password is entered, the software will need to be exited and restarted. The password control window also gives the opportunity to clear the characters input if a typing mistake is made.



Note: Some options will be greyed out or will be hidden when using **monitor** mode. If the full suite of options expected is not available after entering the password for **control** mode, it is likely the password was entered incorrectly.



Note: Passwords must be entered using lower case letters only.



Figure 4.2 – Software start-up screen

After clicking the **Done** button on the above dialogue box, the Software interface screen will open. There are six standard tabs displayed across the top of the screen. These contain all the various functions for programming and monitoring the unit.

PC Utility Software Control Tabs

The PC Utility Software allows programming of the unit through various tabs. In the case of the **System**, **Operation** and **Schedule** tabs, the programming options mirror those available through the *System Config*, *Operation Config* and *Schedule Config* menus accessible through the CQ900 faceplate.

Each tab of the PC Utility Software has a message pane (or dialogue box) in the lower portion of the screen. This is used for displaying confirmation messages, errors, or other general information relating to the operations being carried out by the software.

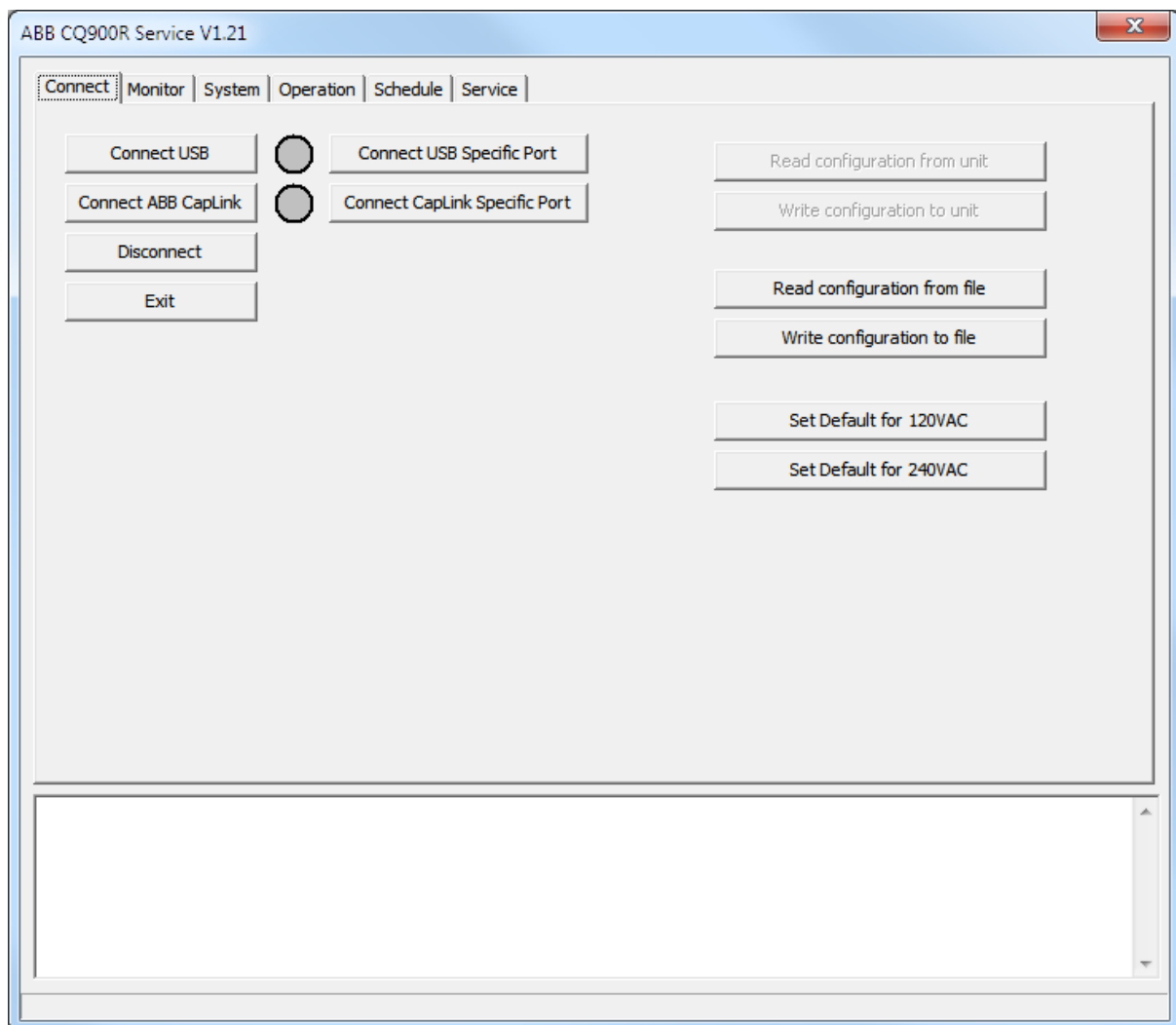

Figure 4.3 – PC Utility Software - Connect Tab

Connect Tab

The **Connect** tab contains the required buttons to connect and communicate with the CQ900 controller unit (figure 4.3).

The top left corner contains buttons used to connect to the CQ900 controller unit. If connecting via USB cable, click on the button “**Connect USB**”. The software will automatically search all available USB ports on the computer and make a connection if available. The message pane (lower part of screen) will notify you once a connection has been made.

If your PC has Bluetooth activated or is connected to peripherals which utilise virtual ports, the PC Utility Software may not be able to find the connected CQ900 automatically. If this occurs click the “**Connect USB Specific Port**”. This gives you the option of selecting the port which your controller is connected to via the connection options box.

Under the **Port** drop down box, the available ports will be listed. Depending on your PC this can vary, and may require some trial and error to select the correct one.

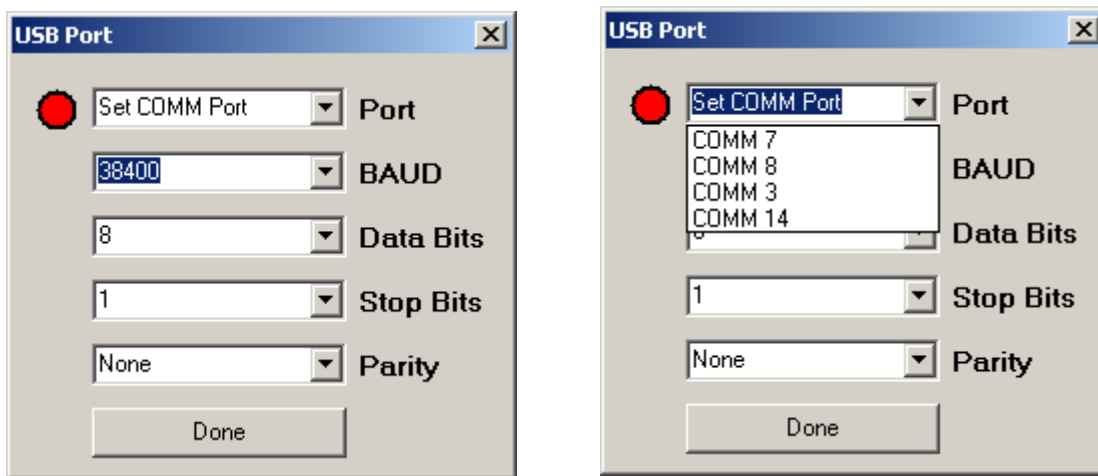

After selecting the correct port and clicking the *Done* button, you will be returned to the **Connect** tab. If the unit has connected correctly, the greyed out light between the *Connect* and *Connect Specific port* buttons will illuminate green and a message will appear in the message pane in the lower half of the screen (Figure 4.4). You can disconnect and reconnect (with different controllers as required) by the same method. Press *Disconnect* to release the controller and close the port each time a controller is disconnected / reconnected to the PC.



SPECIAL NOTE: If you have tried both of the above methods and still cannot connect to the controller, you may need to update the USB driver on your PC. The file **CDM 2.04.16.exe** can be provided by ABB Australia and is supplied on the installation CD provided with each unit. Simply execute the file to update your driver then retry the above steps.

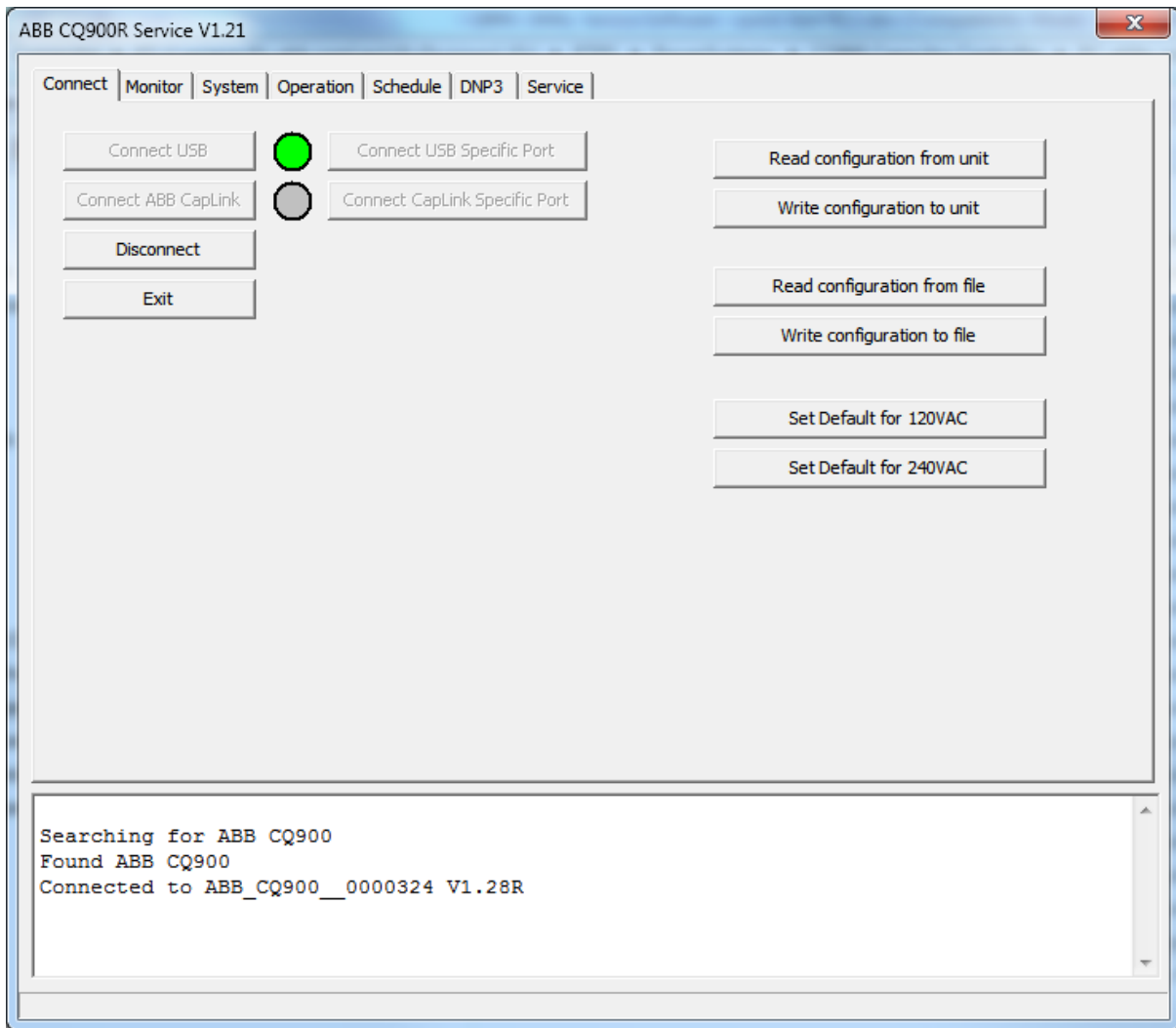



Figure 4.4 – PC Utility Software – Unit successfully connected

On the right hand side of the **Connect** tab are buttons which allow reading / writing of information to and from the unit and to file. The following is a brief outline of the function of each button:

<p>Read configuration from unit</p>	<p>Once connected to the controller, this reads all the current settings programmed into the unit and populates the various fields in the software tabs with the programmed values.</p> <ul style="list-style-type: none"> • If a CQ900 has been installed in the field, it is often useful to look at what is currently programmed in the unit before making changes to the settings.
<p>Write configuration to unit</p> 	<p>After making the required changes to the settings in the software tabs, click this button to send the changes to the controller.</p> <ul style="list-style-type: none"> • Changes to settings made within the software will not be sent to the controller

	unless this button is pressed.
Read configuration from file	<p>Populates the <i>utility software</i> fields with values previously set up and saved in a configuration file.</p> <ul style="list-style-type: none"> • If these settings are then to be programmed / saved to the CQ900 unit, the <i>Write configuration to unit</i> button must also be pressed.
Write configuration to file	<p>Once the software fields are populated with the desired settings, click to create a file which can be retrieved (<i>Read configuration from file</i>) at a later date.</p> <ul style="list-style-type: none"> • It is a good idea to save a config file of each unit (or similarly programmed units) that are deployed. This can allow troubleshooting without having to remove the unit from service. • Be sure to give each config file a meaningful name for future reference.
Set Default for 120VAC	Populates the various programmable options with default values for a unit to be run on a 120V system.
Set Default for 240VAC	Populates the various programmable options with default values for a unit to be run on a 240V system.

Monitor Tab

To the right of the Connect tab is the **Monitor** tab. This contains a panel which displays the current real time values being sensed by the controller. The values shown will depend in part on the hardware being used. If current sensing is disabled, there will be no values that require the current sensor displayed (Figure 4.5). If current sensing is enabled (Figure 4.6) current and power factor will also be displayed.

The values shown are automatically updated every 1 second as long as a connection is present.

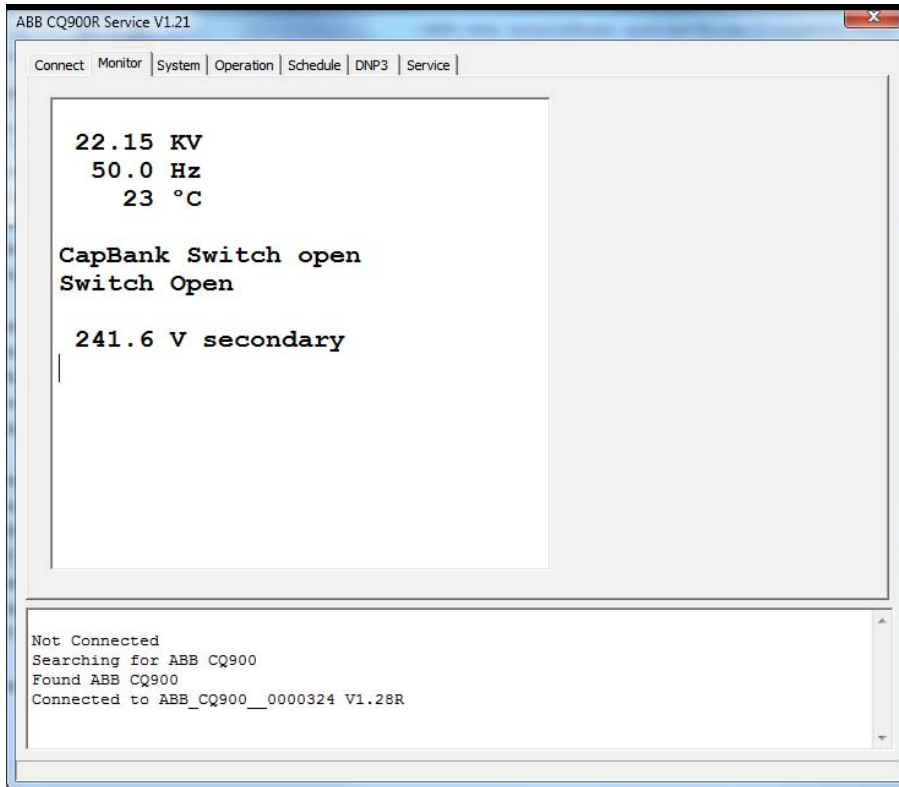

Figure 4.5 – monitor display with current sensor disabled

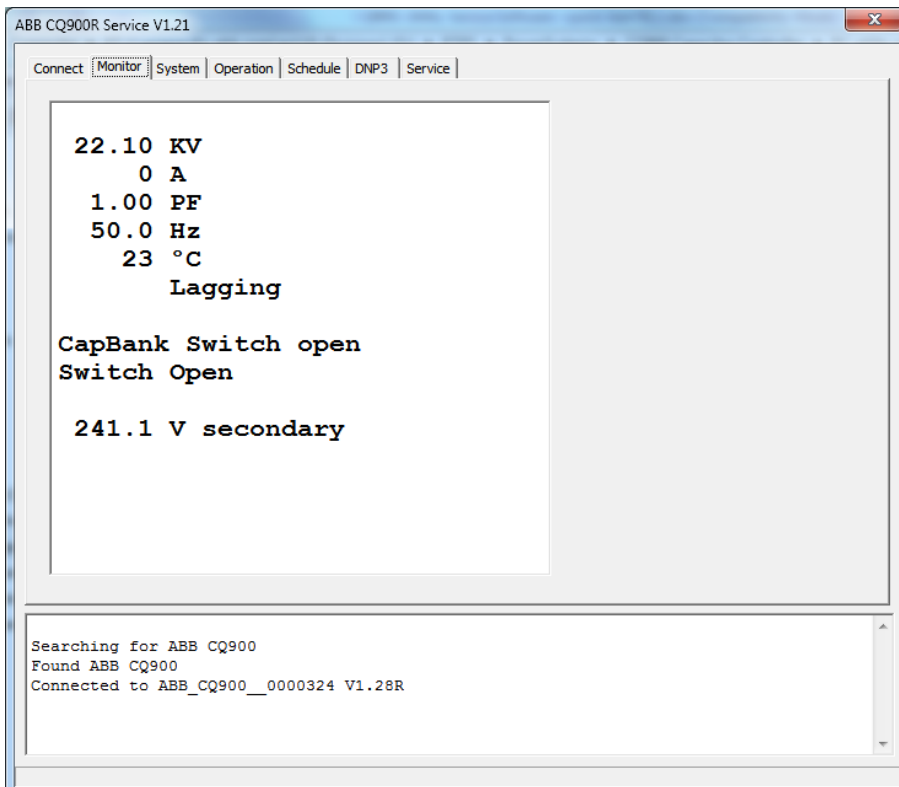

Figure 4.6– monitor display with current sensor enabled

System Tab

The **System** tab (figure 4.7) contains settings which typically specify the “fixed” aspects of the CQ900 operation. Once these items have been programmed it is likely that they will not be altered for the remaining life of the unit.

The purpose and operation of the available options are described in chapter 3 of this manual with the exception of the following:

- **Set Time:** The controller has its onboard clock re-programmed to match the system time of the PC that the unit is connected to.
- **Check Time:** Displays the CQ900’s current time in the message pane allowing verification with other time based devices.
- **Custom Primary Voltage Ratio:** If the primary side voltage of the installed VT / PT is not available from the drop down list, the *Custom ratio* check box can be ticked allowing the user to input their own value (in volts).
- **Custom Secondary Voltage Ratio:** If the secondary side voltage of the installed VT / PT is not available from the drop down list, the *Custom ratio* check box can be ticked allowing the user to input their own value (in volts)



Note:

It is important that whether or not a current sensor is fitted that the “**Current Sense Fitted**” reflects this. Incorrectly selecting the wrong values can cause controller errors to trigger.



Note:

If any settings are changed in the **System Tab**, they will not take effect in the unit (if connected) until the “*Write Configuration to Unit*” button is pressed on the Connect Tab

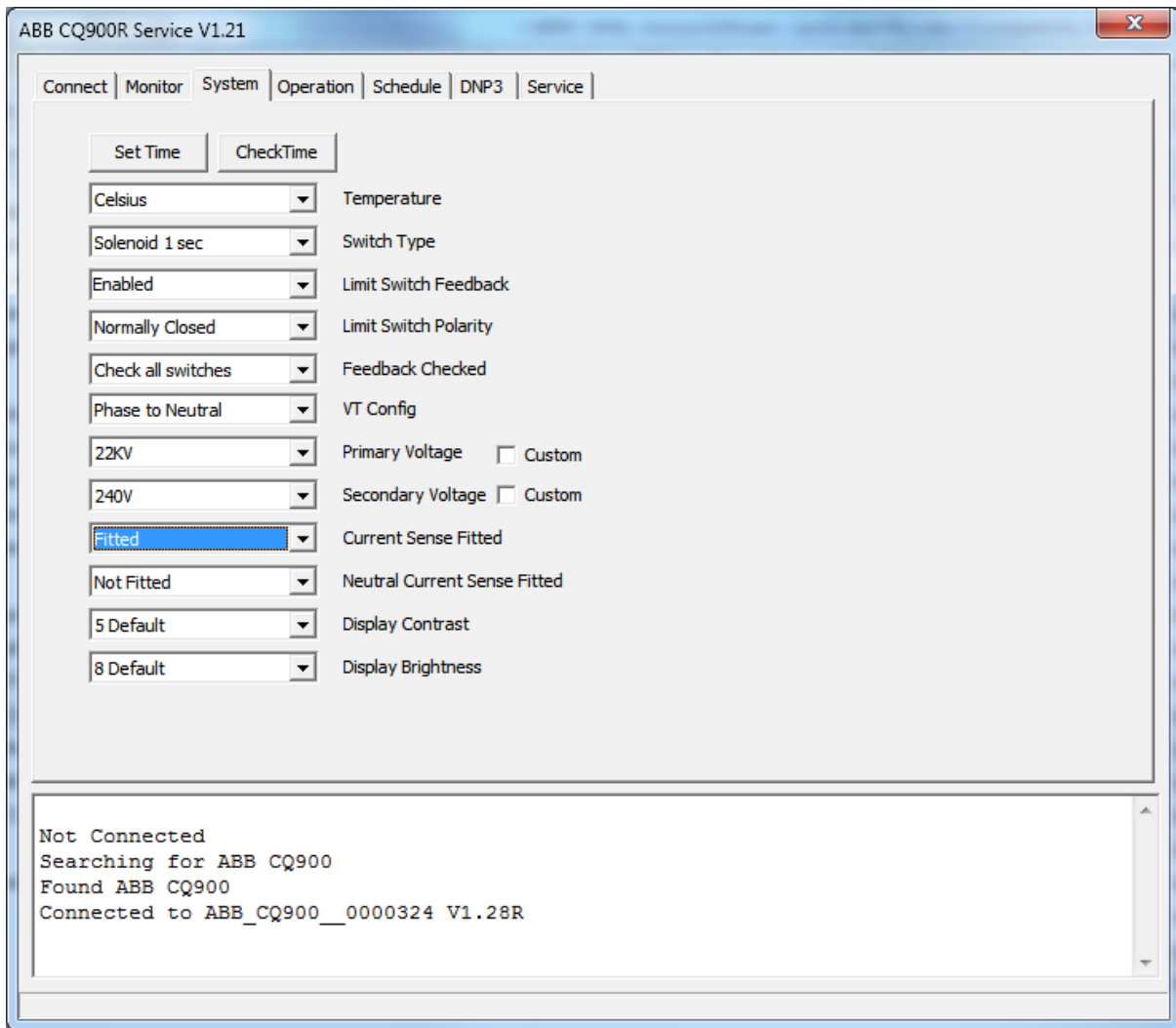

Figure 4.7 – PC Utility Software – System Tab

Operation Tab

The **Operation** tab (figure 4.8) contains most of the settings which control the operational parameters of the unit.

The left hand side of the tab contains settings which specify how the unit will behave under different condition, while the right hand side contains the various thresholds and time delays which the CQ900 will use when determining what actions to take.

The purpose and operation of the available options are described in chapter 3 of this manual.



Note: The values shown in the **Thresholds** section are populated by default when the *Set default* for 120V or 240V buttons are selected on the **Connect** tab.

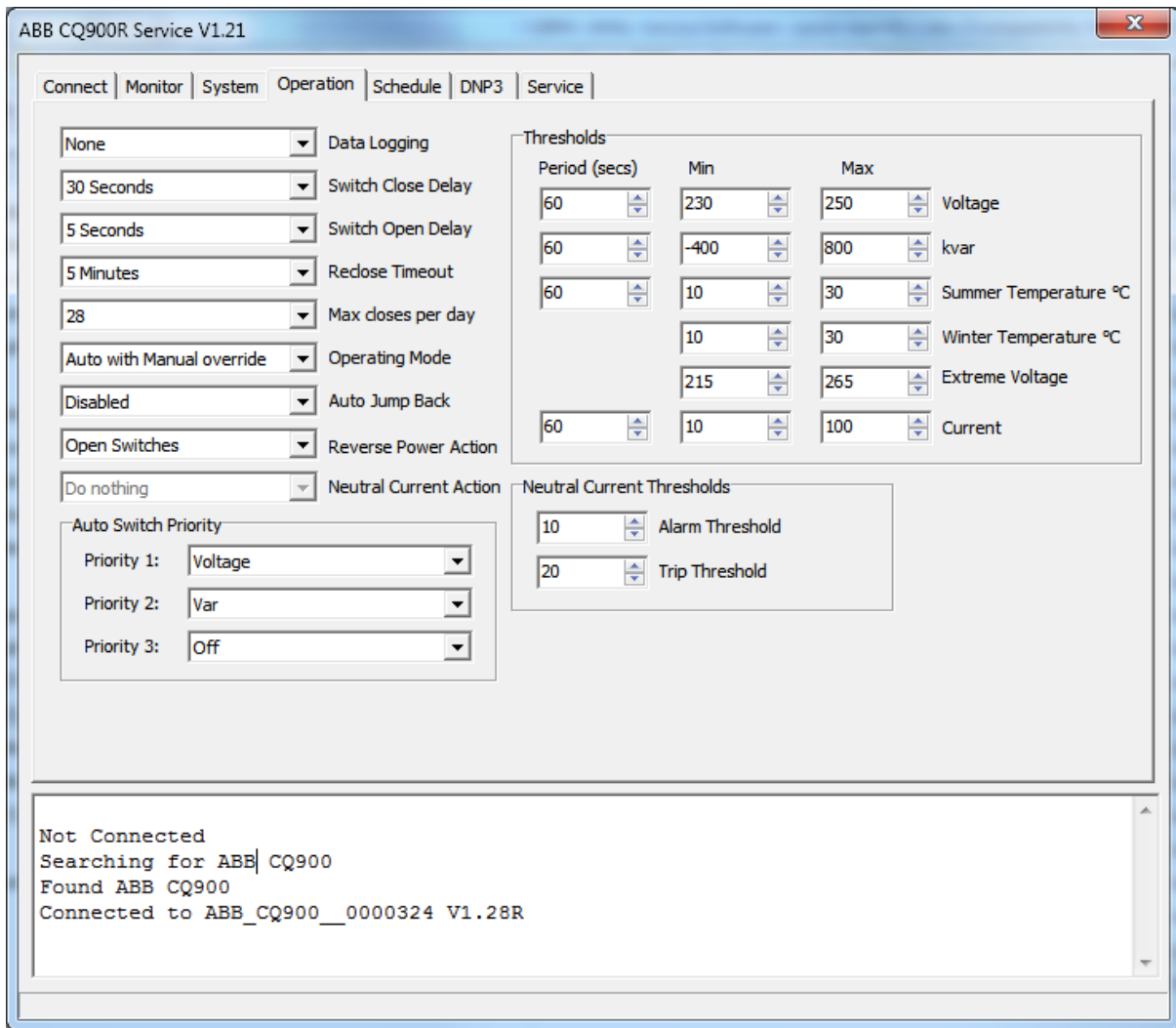

Figure 4.8 – PC Utility Software – Operation Tab

Depending on whether primary current or neutral current sensing has been enabled in the System Tab, some options will appear greyed out and not editable on the Operation Tab. This also applies to the Auto Switch Priorities, whereby current or var will not be able to be selected unless current sensing has been enabled.

Current and var also cannot both be selected in the same auto-switching scheme. This is due to the requirement for the current sensor to be located either side of the capacitor bank in each case. Please contact ABB if unsure.



Note: If any settings are changed in the **Operation Tab**, they will not take effect in the unit (if connected) until the “*Write Configuration to Unit*” button is pressed on the Connect Tab

Schedule Tab

The **Schedule** tab (figure 4.9) contains all the programmable parameters which control the auto switching schedule of the unit.

The schedule menu will only be referred to by the CQ900 if *schedule* is selected as one of auto switch operating modes (or part of a combination of operating modes) in the **Operation** tab.

The purpose and operation of the available parameters are described in chapter 3 of this manual.

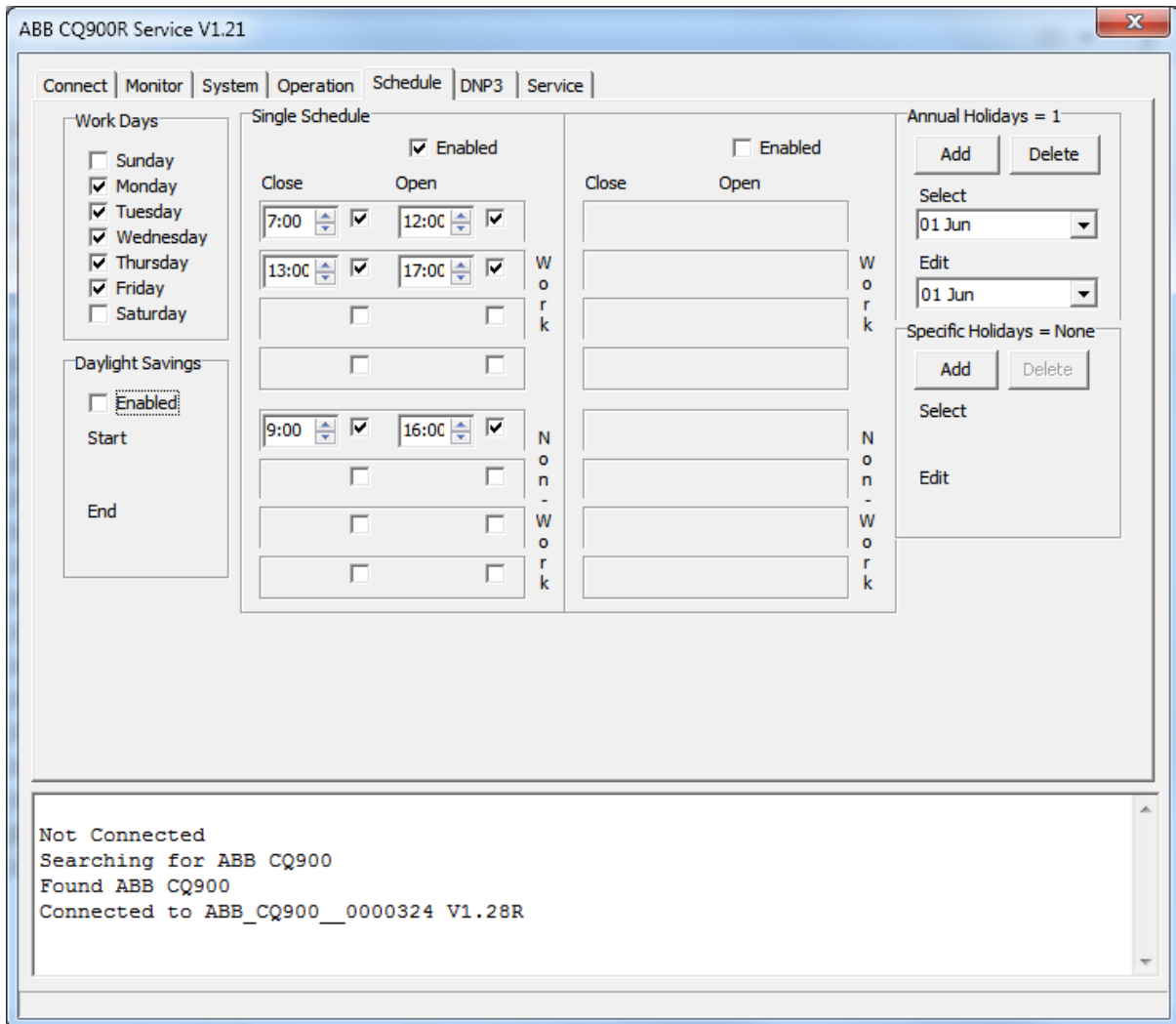

Figure 4.9 – PC Utility Software – Schedule Tab

The CQ900 allows the user to utilise a single switching schedule or independent seasonal schedules. Figure 4.9 shows that ticking only one (either one) of the “enabled” checkboxes activates the single schedule editing, whereas Figure 4.10 shows that ticking both “enabled” checkboxes activates the independent winter and summer schedule.

If single schedule is selected, the schedule will be adhered to for each day of the calendar year, whereas if seasonal schedule is enabled the user must define the start day for each season by selecting the correct day from the drop down calendar – shown in figure 4.10. No end date is required.

Once at least one schedule is activated the user then has the option of selecting how many open / close operations per day they require (up to a maximum of 4 of each). Ticking the checkbox associated with each line will open up the time editing facility for

that operation pair.

Open / Close times can be entered directly into the time box (ensuring HH:MM format is followed), or by utilising the up/down arrows immediately to the right of the time box. If the cursor focus is on the hour digits (left of the colon), clicking the up/down arrows will increase/decrease the hours, if the cursor focus is on the minute digits (right of the colon) clicking the up/down arrows will increase/decrease the minutes.

Enabling *Daylight Savings (or Summer time)* automatically adjusts the time of the unit clock to properly reflect the actual time. Once the enabled checkbox has been ticked, drop down calendar boxes (similar to the one shown in figure 4.10) allow the user to specify the start and finish time of daylight savings.

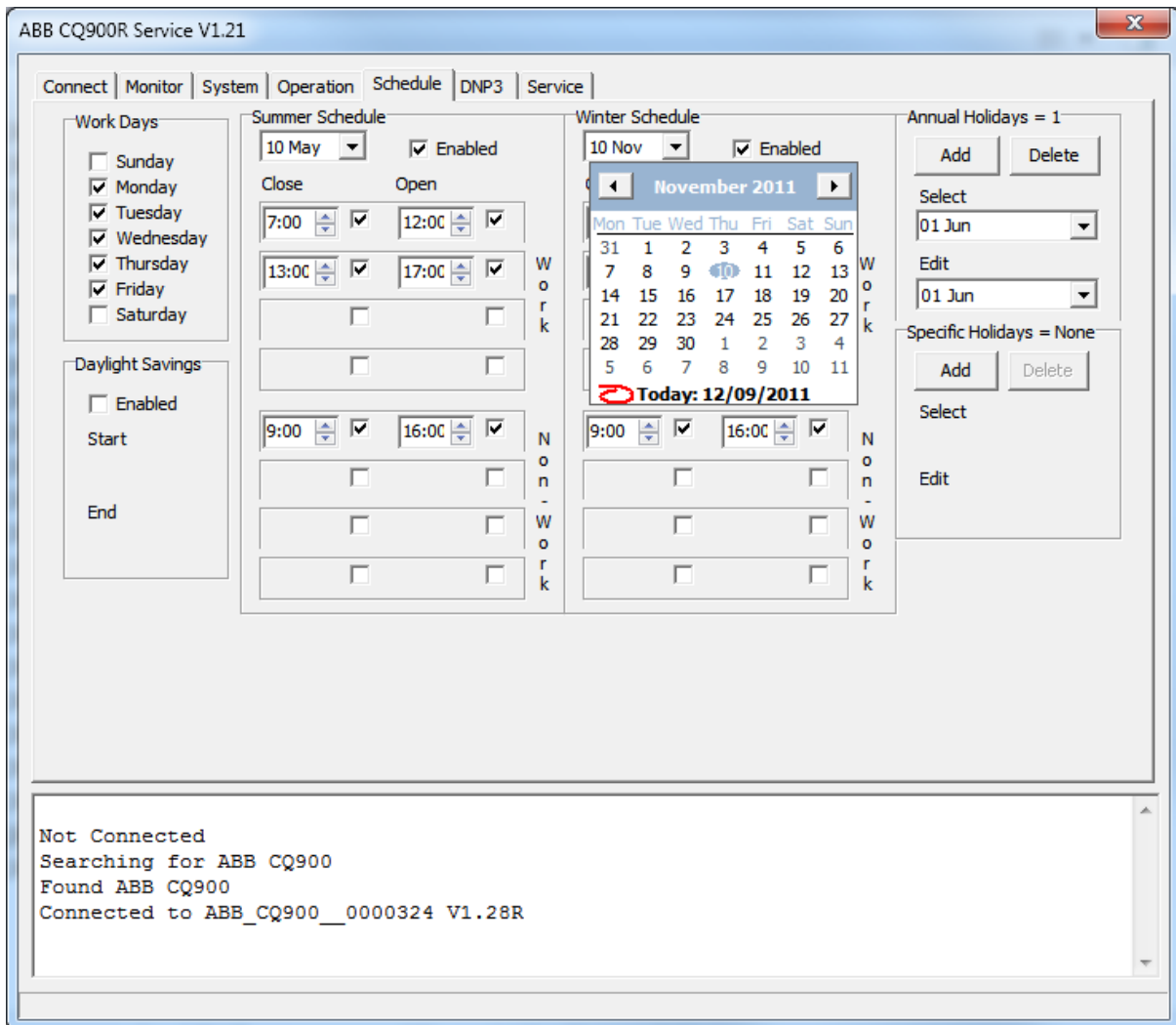



Figure 4.10 – PC Utility Software – Schedule Tab

 Note: Times must be entered in 24 hour format.

 Note: If any settings are changed in the **Schedule Tab**, they will not take effect in the unit (if connected) until the “*Write Configuration to Unit*” button is pressed on the Connect Tab

DNP3 Tab

The DNP3 tab contains configurable items that control how the controller communicates remotely. When the PC Utility Software connects to a CQ900 unit it automatically detects whether the controller is a CQ900R (remote enabled unit) or a CQ900L (Local automatic control only). The DNP3 tab will only appear in the software if the connected unit is a CQ900R.

Settings and options within the DNP3 tab is covered in Chapter 5.

Service Tab

The *Service tab* (figure 4.11) contains administrative control and test functions, many of which are not accessible through the CQ900 unit menus and keypad. With the exception of saving the data log file and monitoring the alarms, utilising the functions contained in the Service tab requires **control** level access.

The *Service tab* is broken up into 6 sections. The following table outlines the various sections with the functions available in each.

Service Control	<ul style="list-style-type: none">• Go To Auto – Puts the unit into Auto mode• Go to Manual – Puts the unit into Manual mode• Open – If the unit is in manual mode, triggers a controller OPEN command (Switch open delay still obeyed)• Close - If the unit is in manual mode, triggers a controller CLOSE command (Switch close delay still obeyed)
Data Log	<ul style="list-style-type: none">• Alarm Statistics – Displays a pop-up dialogue box showing a list of the units active alarms, history alarms and the data log event count (figure 4.12)• Reset Alarms – After confirmation, resets any history and active alarms in the unit. If any alarms are still active, these will reappear as active alarms after a few seconds.• Save Data Log – Downloads the data log from the unit and prompts the user to save the file to a location on their PC.• Clear Data Log – After confirmation, Clears all entries stored in the unit data log
Operations	<ul style="list-style-type: none">• Get Daily Operations – Displays the number of close operations performed since midnight of the current day. Count is displayed in the PC Utility Software message pane (figure 4.11)• Clear Daily Operations – After confirmation, resets the daily operations counter.• Get Total Operations - Displays the number of close operations performed since the unit was installed (or was last reset). Count is displayed in the PC Utility Software message pane (figure 4.11)

	<ul style="list-style-type: none"> • Clear Total Operations – After confirmation, resets the units total operations counter.
Lockout	<ul style="list-style-type: none"> • Set Keypad Lockout – Disables the front panel keypad buttons to prevent tampering. • Release Keypad Lockout – Activates the front panel keypad buttons allowing the user to navigate the CQ900 menus and displays via the keypad.
Calibration	<ul style="list-style-type: none"> • Trim Voltage Calibration – Opens the trim voltage calibration dialogue box (figure 4.13). If there is a discrepancy between the secondary voltage being displayed by the CQ900 and what is measured by a more recently calibrated device, the voltage calibration (and associated measurements) can be trimmed back to match.
Auxiliary Test	<ul style="list-style-type: none"> • Test – Must be pressed before auxiliary testing can begin • LED On / Off – Turns the Auxiliary LED (if fitted) on and off to determine if there is a fault. • Relay On / Off – Turns the internal auxiliary relay on and off to determine if there is a fault.

⚠ **Warning:** The *Trim Voltage Calibration* tab should only be utilised if absolutely required. It permanently alters the internal values the controller uses for calculating parameters such as volts, power factor and reactive power.

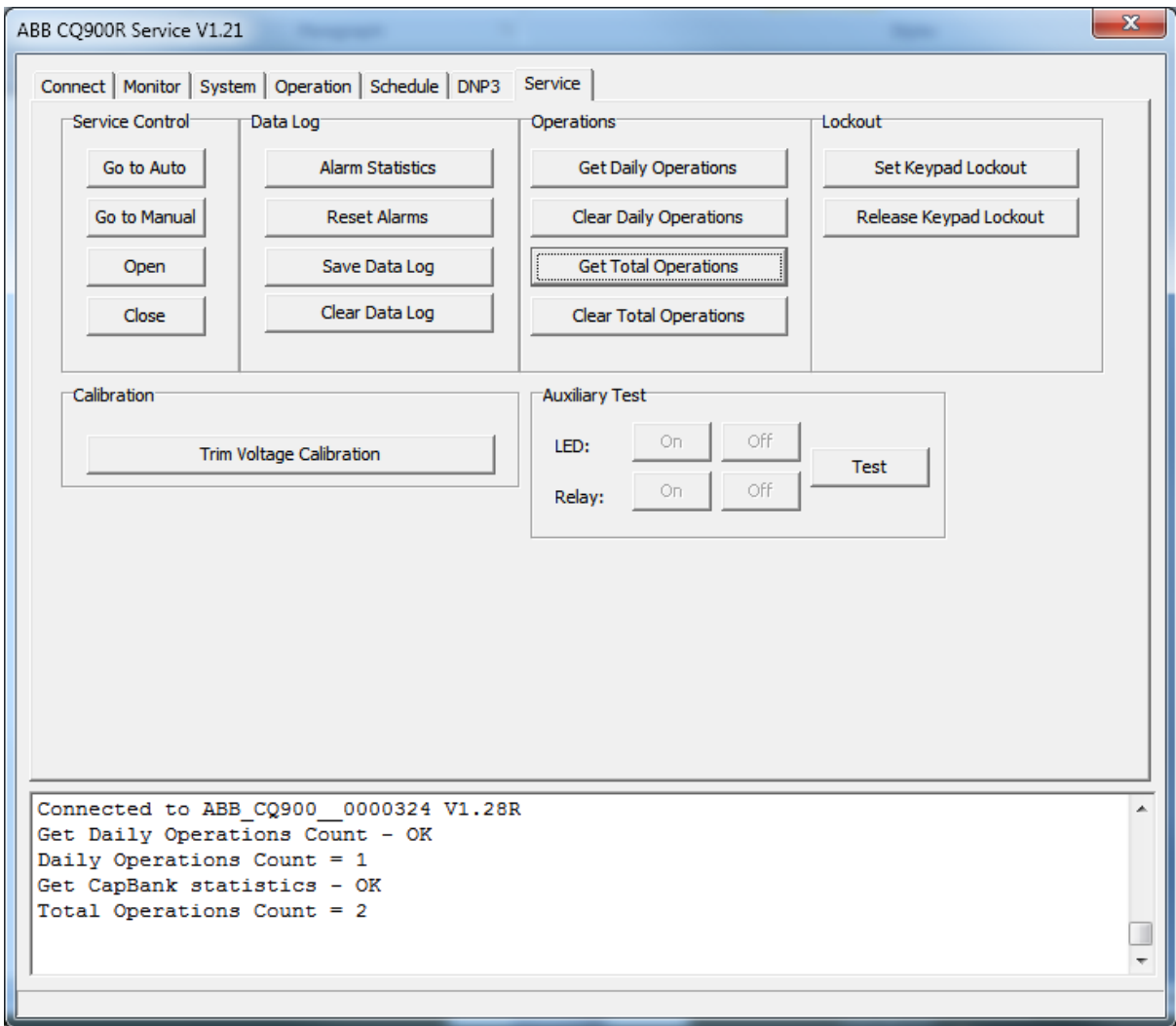

Figure 4.11 – PC Utility Software – Service Tab

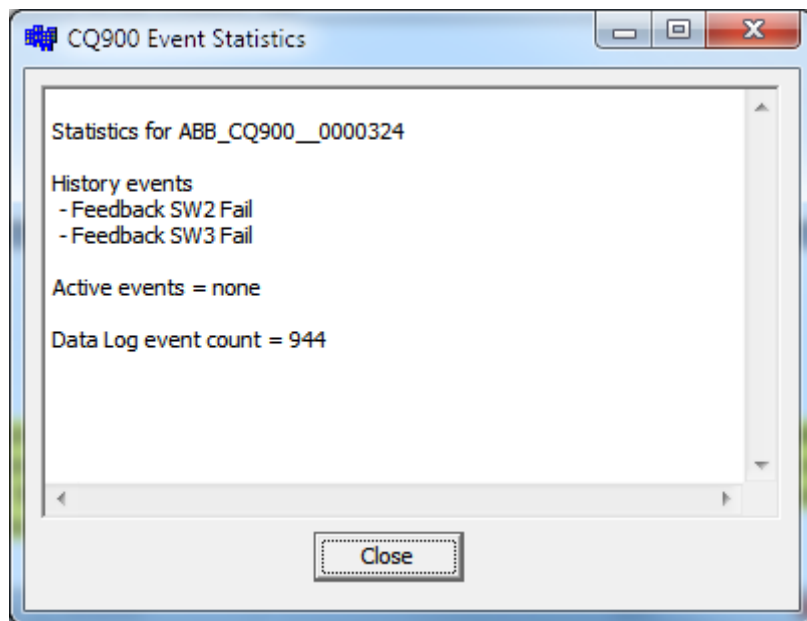

Figure 4.12 – Service Tab – Event / Alarm statistics pop-up dialog box

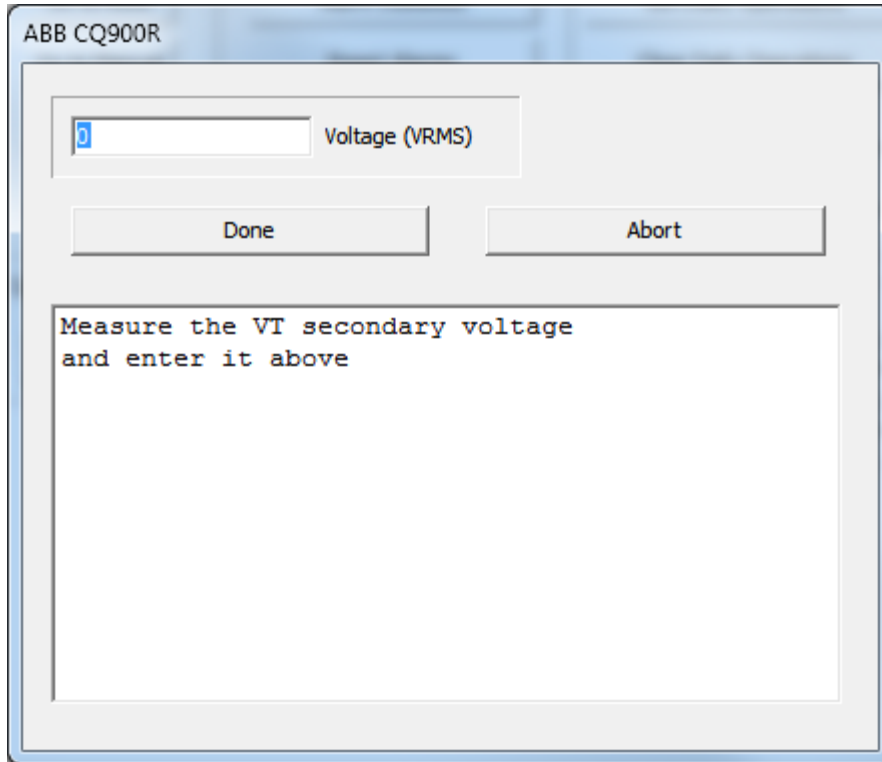

Figure 4.13 – Trim Voltage Calibration dialog box

SECTION 5:

DNP3 Communication Configuration and Operation

The CQ900R series of controllers comes with the ability to monitor network and unit status and report this remotely. It also allows the user to remotely control the capacitor bank according to their specific requirements.

Using DNP3 as the communication protocol allows integration with most utility SCADA network control systems.

DNP3.0 PC Utility Software Configuration Tab

The DNP3 tab (figure 5.1) contains configurable items that control how the CQ900R communicates remotely. When the PC Utility Software connects to a CQ900 unit it automatically detects whether the controller is a CQ900R (remote enabled unit) or a CQ900L (Local automatic control only). The DNP3 tab will only appear in the software if the connected unit is a CQ900R.



Note: The DNP3.0 settings can only be configured using the PC Utility Software.
No remote settings can be configured through the unit face plate

Configuration settings must be completed prior to unit deployment in the field.

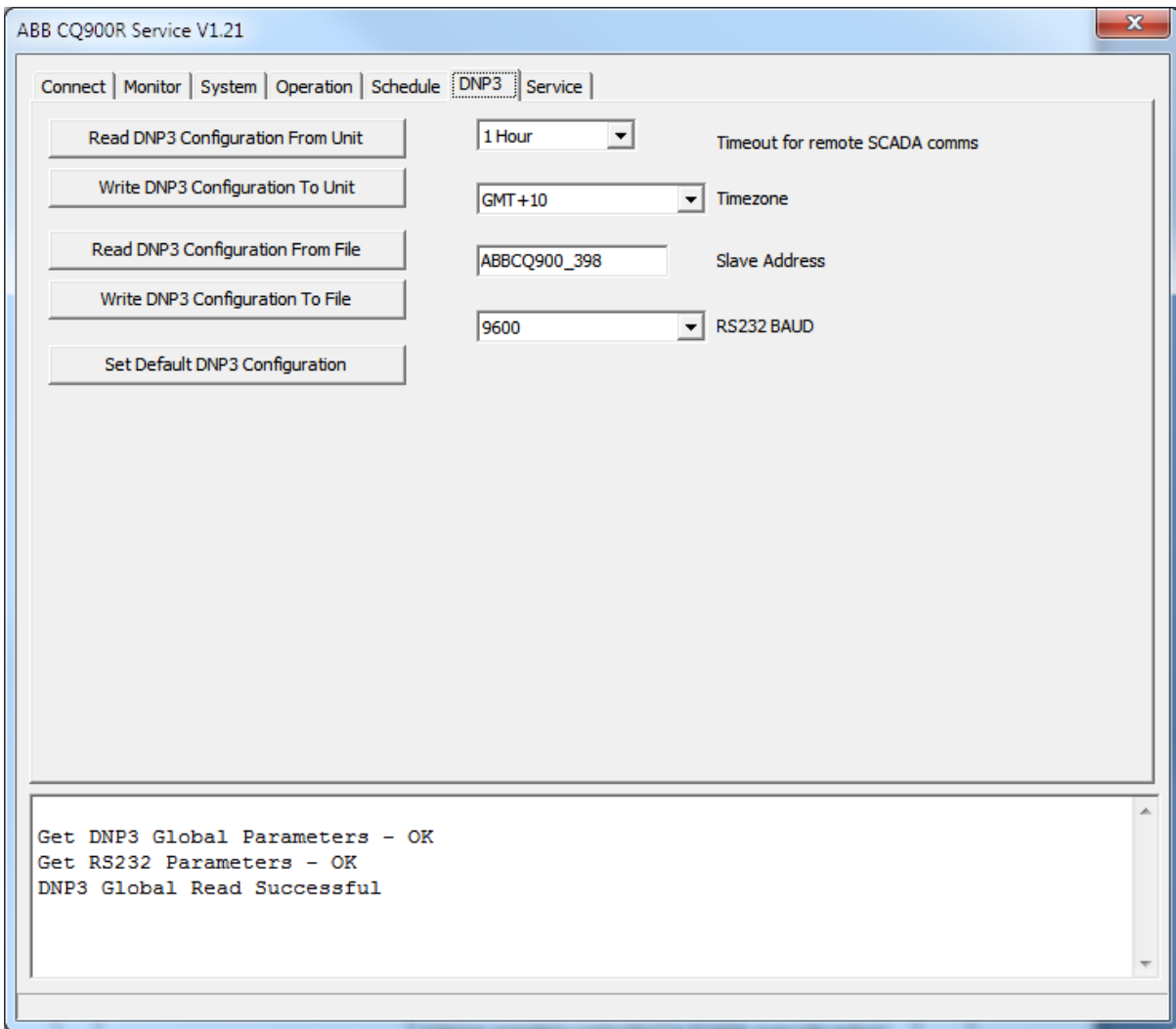

Figure 5.1 – PC utility Software – DNP3 configuration tab

The left hand side of the DNP3 configuration tab contains buttons used to communicate the DNP3 settings to and from the CQ900R controller unit as follows:

<p>Read DNP3 Configuration From Unit</p>	<p>Once connected to the controller, this reads the current DNP3 settings programmed into the unit and populates the fields in the software tabs with the programmed values.</p> <ul style="list-style-type: none"> • If a CQ900R has been installed in the field, it is often useful to look at what is currently programmed in the unit before making changes to the settings.
<p>Write DNP3 Configuration To Unit</p>	<p>After making the required changes to the settings in the tab fields, click this button to send the changes to the controller.</p> <ul style="list-style-type: none"> • Changes to settings made within the software will not be sent to the controller unless this button is pressed.

Read DNP3 Configuration From File	<p>Populates the tab fields with values previously set up and saved in a configuration file.</p> <ul style="list-style-type: none"> • If these settings are then to be programmed / sent to the CQ900R unit, the <i>Write DNP3 Configuration to Unit</i> button must also be pressed.
Read DNP3 Configuration To File	<p>Once the software fields are populated with the desired settings, click to create a file which can be retrieved (<i>Read configuration from file</i>) at a later date.</p> <ul style="list-style-type: none"> • It is a good idea to save a config file of each unit (or similarly programmed units) that are deployed. This can allow troubleshooting without having to remove the unit from service. • Be sure to give each config file a meaningful name for future reference.
Set Default DNP3 Configuration	<p>Populates the programmable fields with default values.</p> <ul style="list-style-type: none"> • Default slave address is the serial number of the CQ900R unit

The right hand side of the DNP3 configuration tab contains the programmable parameters relating to the DNP3 remote comms:

Timeout for remote SCADA comms	<p>To ensure that the unit does not sit idle in the event that remote comms are lost, the CQ900R will revert back to local automatic mode after a set period of communication inactivity.</p> <ul style="list-style-type: none"> • Select the desired timeout from the provided options • The timeout count is reset automatically each time a communication request / action takes place.
Timezone	<p>To ensure correct synchronisation with the master station, the correct universal time zone is required.</p> <ul style="list-style-type: none"> • Select the timezone from the provided options.
Slave Address	<p>Enter the slave address that the master station will use to communicate with the CQ900R.</p> <ul style="list-style-type: none"> • The default slave address is the unique serial number of the unit programmed in the factory. Any unique alphanumeric name can be chosen.
RS232 Baud Rate	<p>Select the desired baud rate that your peripheral system requires from values provided in the drop down box.</p> <ul style="list-style-type: none"> • Unit will need to be restarted after changing the baud rate to take effect.

DNP3 RS232 plug and cable configuration

The RS232 socket receptacle installed on the face plate of the CQ900R is an 8-way, 94V-2 type receptacle. The socket provides both the 12V DC power supply for the modem device as well as the communication signals.

Typical socket plug suitable for connection is Molex part number 39-01-2080 (Allied Electronics (RS-components) Part # 863-0272, element14 Part # 151869) and can be purchased readily from most electronic component suppliers.

Figures 5.2, 5.3 and 5.4 show the unit faceplate RS232 plug receptacle; the cable side plug; and a typical cable with DB9 serial connector and 12VDC fly leads at the other end of the unit plug. Figure 5.5 shows the RS232 pin-out configuration.



Figure 5.2



Figure 5.3



Figure 5.4

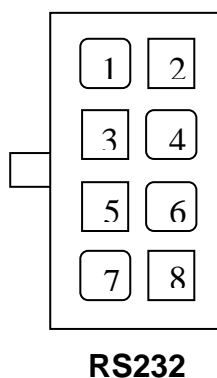

RS232

CQ900R DNP3 RS232 socket pin-out configuration:

1. Receive Data (RXD)
2. 12 VDC +
3. Not Used
4. Not Used
5. Signal Ground (GND)
6. Transmit Data (TXD)
7. 12 VDC -
8. Not Used

Figure 5.5 – CQ900R RS232

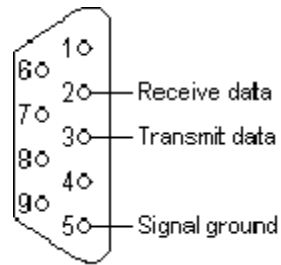

Figure 5.6 – RS232 DB9 pin-out

Figure 5.6 shows a typical DB9 RS232 male pin-out used to connect to the modem / radio device being used. This is the standard pin-out provided on ABB supplied CQ900R-modem connector cables. Custom pre-wired CQ900R-to-modem cables can also be supplied if required. Please contact ABB for information.

Radio / Modem devices

The CQ900R is designed to be compatible with the vast array of radio modem devices on the market.

There are two main criteria that must be adhered to when selecting a modem for use with the CQ900:

- Power required by the radio device is 12VDC
- That the device can accept serial DNP3 input

Radio devices compatible with the CQ900 include (but are not limited to):

- Licensed and unlicensed 900Hz and 2.4GHz spread spectrum frequency hopping (or non-hopping) devices.
- 3.65Ghz licensed spectrum devices
- 3G cellular network modems
- Cable in / fibre out modems

While every effort is made to be interoperable with each third party communication device, it is best to contact ABB with the specifications of the desired communication device before installation.

The modem / radio device is intended to be mounted inside the CQ900R on the supplied aluminium modem mounting plate.



Note: The CQ900R controller should always be treated as a slave unit.

DNP3.0 Points list

The following tables outline the parameters that the CQ900R controller can communicate over DNP3. By default all items are classified as class 0 with unsolicited messaging not supported.

Each master poll will return all *input* and *counter* data pieces.

Binary inputs = 37
 Analog Inputs = 18
 Binary Counters = 5
 Binary Outputs = 8

TABLE KEY:

Column 1: Point number
 Column 2: Point description
 Column 3: Point details
 Column 4: Whether controller requires latched (L) or pulsed (P) signal from master. Applies to outputs only

Binary inputs – Bits are set if condition is true

0	Capacitor bank closed	Last operation sent from controller was a close	
1	Capacitor bank open	Last operation sent from controller was an open	
2	CS Primary current fitted.	Controller has current based measurements enabled	
3	CS Neutral current fitted.	Controller has neutral current sensing enabled	
4	Auto/Manual control mode	Bit set if controller is in Automatic mode. Bit cleared if unit in Manual mode. Bit will remain set if the controller is being remotely controlled (ie SCADA override active)	
5	Remote control mode enabled	Bit set if the unit operating mode is set to Auto with remote fallback.	
6	SCADA override active (unit is in remote mode)	Bit set if unit is in Remote control mode. Bit cleared if unit is local automatic mode. Unit can still be polled if in local automatic mode. Bit will be cleared if remote timeout (binary counter 4) is reached	
7	Any Alarm status set	Any alarm is currently active within the unit. To be used in conjunction with binary inputs 19-30.	
8	BLANK	Not implemented	
9	Neutral current alarm threshold exceeded	Bit set if measured neutral current exceeds the programmed neutral current alarm threshold. Will always return 0 if no neutral current sensor fitted (ie binary input 3 = 0).	
10	Neutral current trip threshold exceeded	Bit set if measured neutral current exceeds the programmed neutral current trip threshold. Will always return 0 if no neutral current sensor fitted (ie binary input 3 = 0).	
11	High V threshold exceeded	Bit set if measured voltage exceeds the programmed high voltage threshold.	
12	Low V threshold exceeded	Bit set if measured voltage drops below the programmed low voltage threshold.	

13	High VAR threshold exceeded	Bit set if measured VAR exceeds the programmed high VAR threshold. Will always return a value of 0 if no current sensor fitted (ie binary input 2 = 0).	
14	Low VAR threshold exceeded	Bit set if measured VAR drops below the programmed low VAR threshold. Will always return a value of 0 if no current sensor fitted (ie binary input 2 = 0).	
15	High Temperature threshold exceeded	Bit set if measured temperature exceeds the programmed high temperature threshold.	
16	Low Temperature threshold exceeded	Bit set if measured temperature drops below the programmed low temperature threshold.	
17	High current threshold exceeded	Bit set if measured current exceeds the programmed high current threshold. Will always return a value of 0 if no current sensor fitted (ie binary input 2 = 0).	
18	Low current threshold exceeded	Bit set if measured current drops below the programmed low current threshold. Will always return a value of 0 if no current sensor fitted (ie binary input 2 = 0).	
19	VT sensor fail	Alarm condition. Measured voltage outside of allowable range.	
20	CS sensor fail	Alarm condition. Measured current outside of allowable range.	
21	Extreme high voltage threshold exceeded	Alarm condition. Measured voltage exceeds the programmed extreme high voltage threshold.	
22	Extreme low voltage threshold exceeded	Alarm condition. Measured voltage has dropped below the programmed extreme low voltage threshold	
23	Max daily operations reached	Alarm condition. If bit is set no open /close instructions will be acted on by the unit. Flag will automatically be reset at midnight, or cleared using binary output 3.	
24	Reverse power present	Alarm condition.	
25	Temperature sensor out of range	Alarm condition. Measured temperature outside of allowable range.	
26	Frequency out of range	Alarm condition. Measured frequency outside of allowable range.	
27	RTC fail	Alarm condition. Error with real time clock settings	
28	Dataflash fail	Alarm condition	
29	Configuration Item corrupt	Alarm condition	
30	Switch fuse blown	Alarm condition. 10A Switch fuse needs replacing.	
31	Temperature is in Fahrenheit	Bit set if temperature reported is in Fahrenheit. Cleared if in Celsius	
32	Reclose block in effect	Bit set for a period of either five or ten minutes (as programmed in the operation config settings) after an open switches operation.	
33	Any switch feedback error	Alarm condition. Bit set if controller detects feedback from any switch different to last operation instruction. Valid regardless of switch feedback type selected.	
34	Switch 1 feedback error	Alarm condition. Bit set if feedback from switch one is different to last operation instruction. Only valid if switch feedback type is set to "check all switches".	

35	Switch 2 feedback error	Alarm condition. Bit set if feedback from switch two is different to last operation instruction. Only valid if switch feedback type is set to “check all switches”.	
36	Switch 3 feedback error	Alarm condition. Bit set if feedback from switch three is different to last operation instruction. Only valid if switch feedback type is set to “check all switches”.	

Analogue inputs – Values measured/calculated by the controller. Values updated every second.

0	V Primary	Each count is equal to 1VAC RMS.	
1	V Secondary	Each count is equal to 0.1VAC RMS.	
2	I Primary	Each count is equal to 0.1A RMS. Will return a value of 0 if no current sensor fitted.	
3	I Neutral	Each count is equal to 0.1A RMS. Will return a value of 0 if no neutral current sensor fitted.	
4	I Spare	Not used. Returns value of 0	
5	kvar	Each count is equal to 1kvar. Will return a value of 0 if no current sensor fitted.	
6	kW	Each count is equal to 1kW. Will return a value of 0 if no current sensor fitted.	
7	kVA	Each count is equal to 1kVA. Will return a value of 0 if no current sensor fitted.	
8	Temperature	Each count is equal to 0.1 deg (Celsius or Fahrenheit as pre-defined)	
9	Power factor	Each count is equal to 0.01. Will return a value of 0 if no current sensor fitted.	
10	lag/lead	Possible values as per below: 0 No current sensor fitted 1 Power factor lagging 2 Power factor leading	
11	Frequency	Each count equals 0.1Hz	
12	Auto Switch Priority 1:	Possible values as per below: 0 Not used 1 Voltage 2 Var 3 Temperature 4 Schedule 5 Current	
13	Auto Switch Priority 2:	Possible values as per below: 0 Not used 1 Voltage 2 Var 3 Temperature 4 Schedule 5 Current	
14	Auto Switch Priority 3:	Possible values as per below: 0 Not used	

		1 Voltage 2 Var 3 Temperature 4 Schedule 5 Current	
15	BLANK	Not implemented	
16	Last operation V delta value	Each count is equal to 0.1VAC. Signed value showing whether voltage is less or more than voltage before switching.	
17	Last operation kvar delta value	Each count equals 1kvar. Will return a value of 0 if no current sensor fitted.	

Binary Counters – 16-bit counters, ie 0 to 65,535. Counters reset to zero on overflow.

0	Daily closures	Number of switch operations recorded for the current day. Resets to 0 automatically at midnight. Counter increments by 1 with each close operation.	
1	Total closures	Number of switch operations since the last counter reset (in PC utility software). Counter increments by 1 with each close operation.	
2	Operation counter 2	Not implemented. Returns value of 0	
3	Reclose block timer countdown	Seconds remaining until switches can be re-closed	
4	SCADA operation timeout countdown	Time remaining (in minutes) until remote SCADA operation times out. Maximum value of 1440. Resets to max value each time a new poll or instruction is received from the master.	

Binary outputs - (write to using Select Before Operate)

0	CapBank close	Write a 1 to the unit to close the cap bank. Clear the bit to open the bank. Only valid when the unit is in remote control mode	L
1	SCADA override activate	write a 1 to this to enforce remote control – must have remote with auto fallback mode set in the controller	L
2	Neutral current trip reset	Write anything to this to remotely release the trip when in remote control	P
3	Reset daily closures counter	Resets the count present in Binary Counter 0 back to a value of 0.	P
4	Reset total closures counter	Resets the count present in Binary Counter 1 back to a value of 0.	P
5	Reset alarms	Write a 1 to reset active and history alarms in the unit	P
6	Clear unit data log	Write a 1 to clear the unit data log.	P
7	Reset Unit	Resets and reboots the CQ900R.	

SECTION 6:

CQ900 SMART CONTROLLER SPECIFICATIONS

Operating electrical characteristics

- Supply Power Requirements: 90 - 264VAC universal power supply
- Line frequency: 47 to 63Hz real time monitoring
- Power consumption: 10VA max

Electrical isolation/protection

- 450V varistor protection (MOV)
- Transient voltage suppressors for fast spike and ESD protection (1500V 8/20us)
- Electrically protected auxiliary digital inputs.

Fuse protection

- Unit protection: 2 Amp slow blow (M205)
- Switch protection: 10 Amp slow blow (M205)

Operating Environment Characteristics

- Operating temperature: - 40°C to + 70°C (- 40°F to + 158°F)
- Unit display operating temperature: -20°C to +70°C (-4°F to + 158°F)
- Humidity range: 5% to 95% (non-condensing)

Measurement Sensor Performance

- Voltage Measurement: ± 375.8Vpeak (± 264Vrms) range
0.2 VAC resolution
± 1% accuracy
- Current 0 to 600 Amp range
0.5 Amp resolution
± 1% accuracy (+ sensor accuracy)
- Phase Angle -179 deg to +180 deg range
1 deg resolution
± 0.1% accuracy
- Temperature measurement: - 40°C to + 70°C
(- 40°F to + 158°F) range
1°C (1°F) resolution

Output contacts (relays)

- 2 x 20 Amp potential free contacts (1 open, 1 close)
- Contact maximum continuous load: 20 A
- Contact maximum in-rush: 100 A
- Contact closure period: user selectable range between 100 ms to 10 seconds (as well as fixed closed for electrically held switch operation)

Switching Settings

- Manual OPEN and CLOSE
- Auto Control Switching Modes:
 - Auto off (Default)
 - Voltage
 - kvar
 - Current
 - Temperature
 - Schedule
- Switch on schedule:
 - Single or seasonal
 - User defined work and non-workdays.
 - Up to 4 open / close times per work and non-workdays.
- Switch on Temperature range: -40°C to +50°C (-40°F to +122°F)
- Switch on VAR range: -10 MVAR to +10 MVAR
- Switch on Current range: 10A to 600A
- Independent Open/Close time delay: 5s (30s for close) to 10mins
- Maximum daily operations: 1 to 30 per day
- User defined logging periods: 30secs to 60 mins

Enclosure/mounting

- Lockable, IP54, powder coated, 304 grade stainless steel casing.
- Pole mounting brackets provided as standard. Optional wall and meter socket mounts are also available.

Memory/calendar

- Real time clock synchronised with line frequency
- Replaceable battery (for unpowered clock maintenance) : 3.6V lithium cell – 10 year life (unpowered state)
- Calendar:
 - 20 years preset
 - 30 user definable holidays
 - Daylight savings time recognition
 - Fully selectable work days vs. non-work days
 - Automatic season adjust (if seasonal schedule defined)

- Non-volatile flash data logging memory – 10,000+ logs record
- Non-volatile storage of operating parameters in data flash

Display

- 4 line x 20 character backlit liquid crystal display with contrast and brightness control

Communications

- Unit configuration and data log transferable via USB2.0 port on controller to PC
- Optional **ABB CapLink** short range wireless communications (2.4GHz) allows similar functionality to the USB-PC link without the need to directly connect to the unit. Communication range up to 50 metres.
- DNP3 over RS232 (CQ900R only)
 - Radio modem power supply: 12VDC, 2.0A continuous

Quality

- All CQ900 controllers are fully factory tested (including circuit board burn-in testing), calibrated and ready for installation
- All printed circuit boards conform to IPC-D-2221
- All components RoHS compliant
- Unit conforms to CE mark (C-Tick) and all applicable electrical standards
- Manufactured in ISO-9001 and ISO14001 certified facility.

Standards / Testing compliance

- CFR 47, FCC Part 15 Class B
- Industry Canada ICES-003 Class B
- ACMA C-Tick compliance
- EU RTTE directive 1999/5/EC - CE compliance

SECTION 7:

PART NUMBER AND ORDERING INFORMATION - HARDWARE WIRING CONFIGURATION

The following table outlines the part number notation for the CQ900 controller range

Controller Selection Table	CQ900	R	P	07	C	N
Control Type: R - Remote control enabled L - Local control only						
Mounting Configuration: P - Standard pole mount bracket A - Meter base socket mount configuration "A" B - Meter base socket mount configuration "B" C - Meter base socket mount configuration "C" D - Meter base socket mount configuration "D"						
Plug configuration: 00 - No cable plug fitted (Meter base mount only) 02 - 2-pin neutral current plug (Meter base mount only) 07 - Standard 7-pin plug (Pole mount bracket) 09 - Standard 7-pin plug + 2-pin neutral current plug (Pole mount bracket)						
ABB CapLink: C - Fitted (includes removable antenna) X - Not fitted						
Neutral Current Sensing Option N - Neutral current sensing option enabled X - Neutral current sensing not fitted. * If neutral current sensing option selected, plug type 02 or 09 must be selected.						
Optional Extras: CQ900-CLD - ABB CapLink PC USB dongle						

7 - Pin Panel Plug Configuration

The below diagram illustrates the pin connection and wiring table applicable to the standard 7-pin plug located at the bottom of the controller.

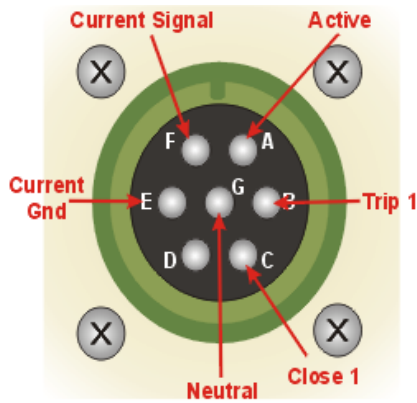

Controller Panel Mount Plug
(External View)

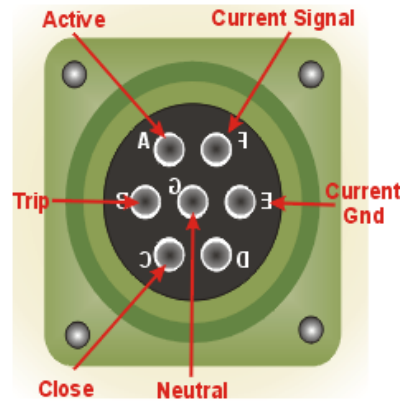

Controller Panel Mount Plug
(Internal View)

Pin Label	Wire Colour (Internal)	Signal
A	Red	Active (Hot)
B	White	Switch Trip
C	Dark Blue	Switch Close
D	---	Not Used
E	Grey	Current Ground
F	Brown	Current Signal
G	Black	Neutral

Controller Cable Socket Configuration

The following diagram illustrates the required 7-pin arrangement and pin designation when using a 7-pin connection cable.

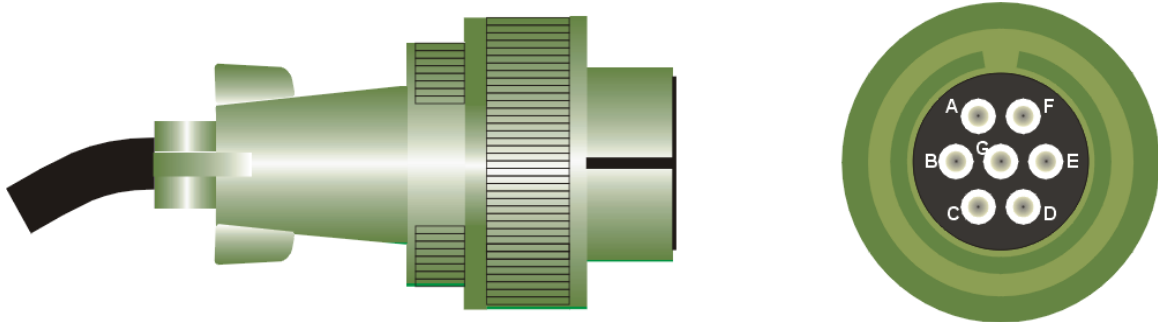

Pin Label	Signal
A	Active (Hot)
B	Switch Trip
C	Switch Close
D	Not Used
E	Current Ground
F	Current Signal
G	Neutral

Meter Base Socket signal outputs

The CQ900 can be supplied accommodating a range of meter base wiring configurations. Correct meter base jaw options must be specified at time of ordering.

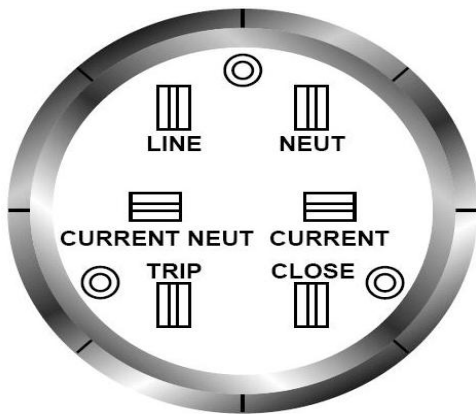

6 JAW OPTION A

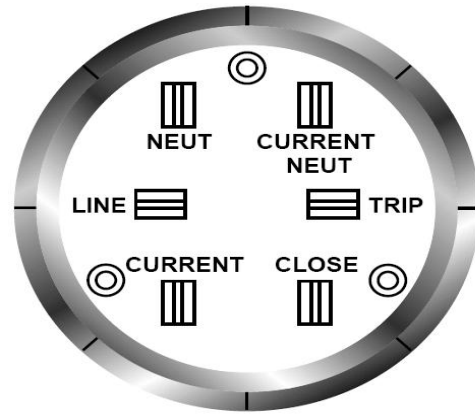

6 JAW OPTION C

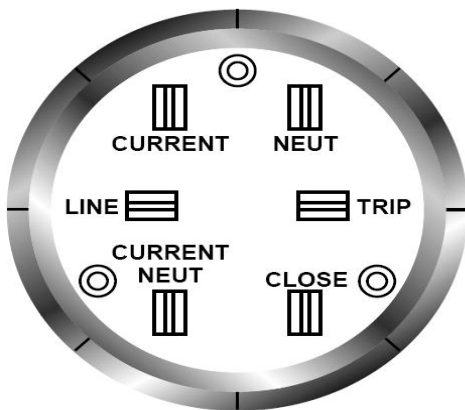

6 JAW OPTION B

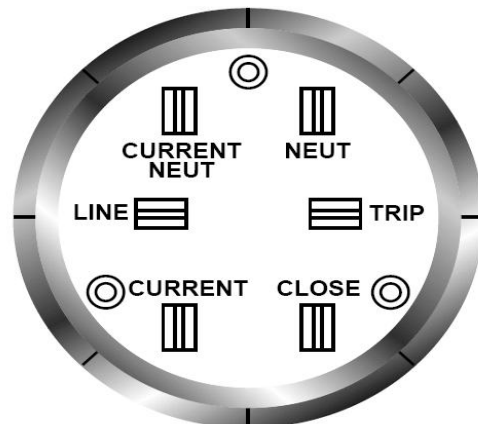

6 JAW OPTION D

CQ900 SMART CONTROLLER DISPLAY MENU STRUCTURE

DIAGRAM 1 OF 4

Navigation Keys:

CANCEL

- Escape from a screen without saving changes
- Exit from a menu

ENTER

- Enter into a menu
- Activate a menu item for change
- Save the value of setting you have changed

UP and DOWN arrows

- Scroll through the display screen options
- Scroll through available preset options when changing menu items / settings

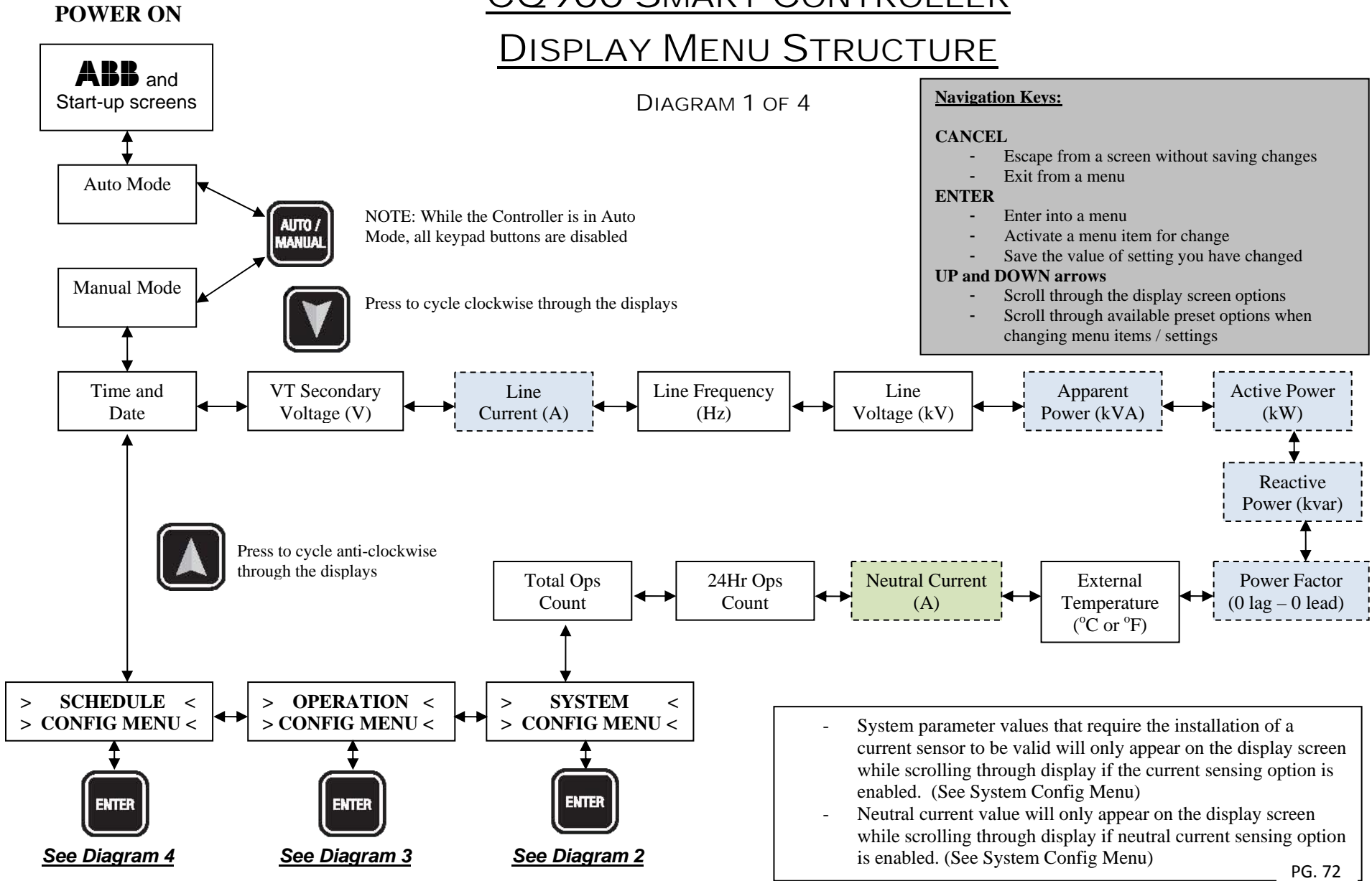

CQ900 SMART CONTROLLER

SYSTEM CONFIG MENU STRUCTURE

FROM DIAGRAM 1

DIAGRAM 2 OF 4

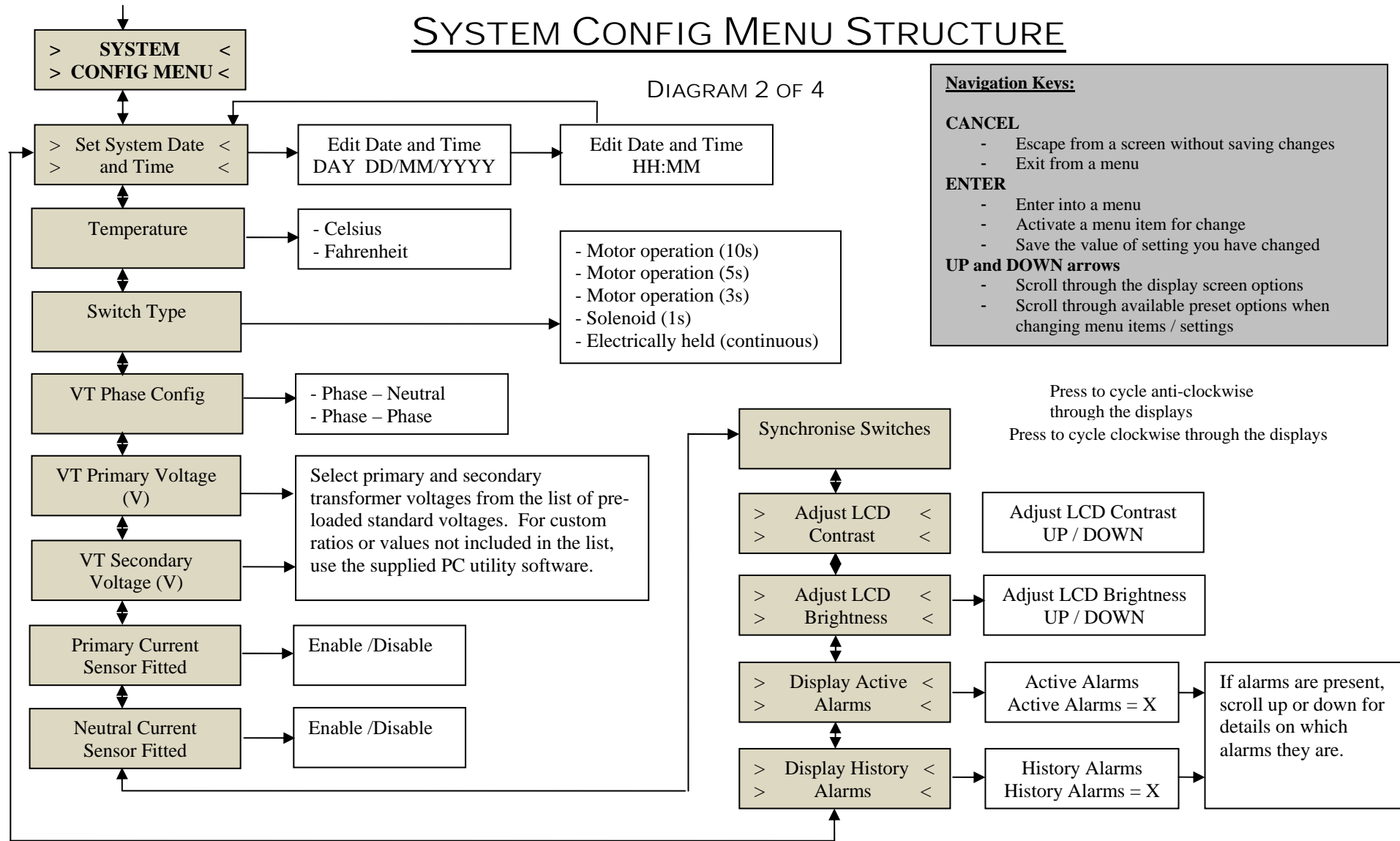

CQ900 SMART CONTROLLER

OPERATION CONFIG MENU STRUCTURE

FROM DIAGRAM 1

DIAGRAM 3 OF 4

Navigation Keys:

CANCEL

- Escape from a screen without saving changes
- Exit from a menu

ENTER

- Enter into a menu
- Activate a menu item for change
- Save the value of setting you have changed

UP and DOWN arrows

- Scroll through the display screen options
- Scroll through available preset options when changing menu items / settings

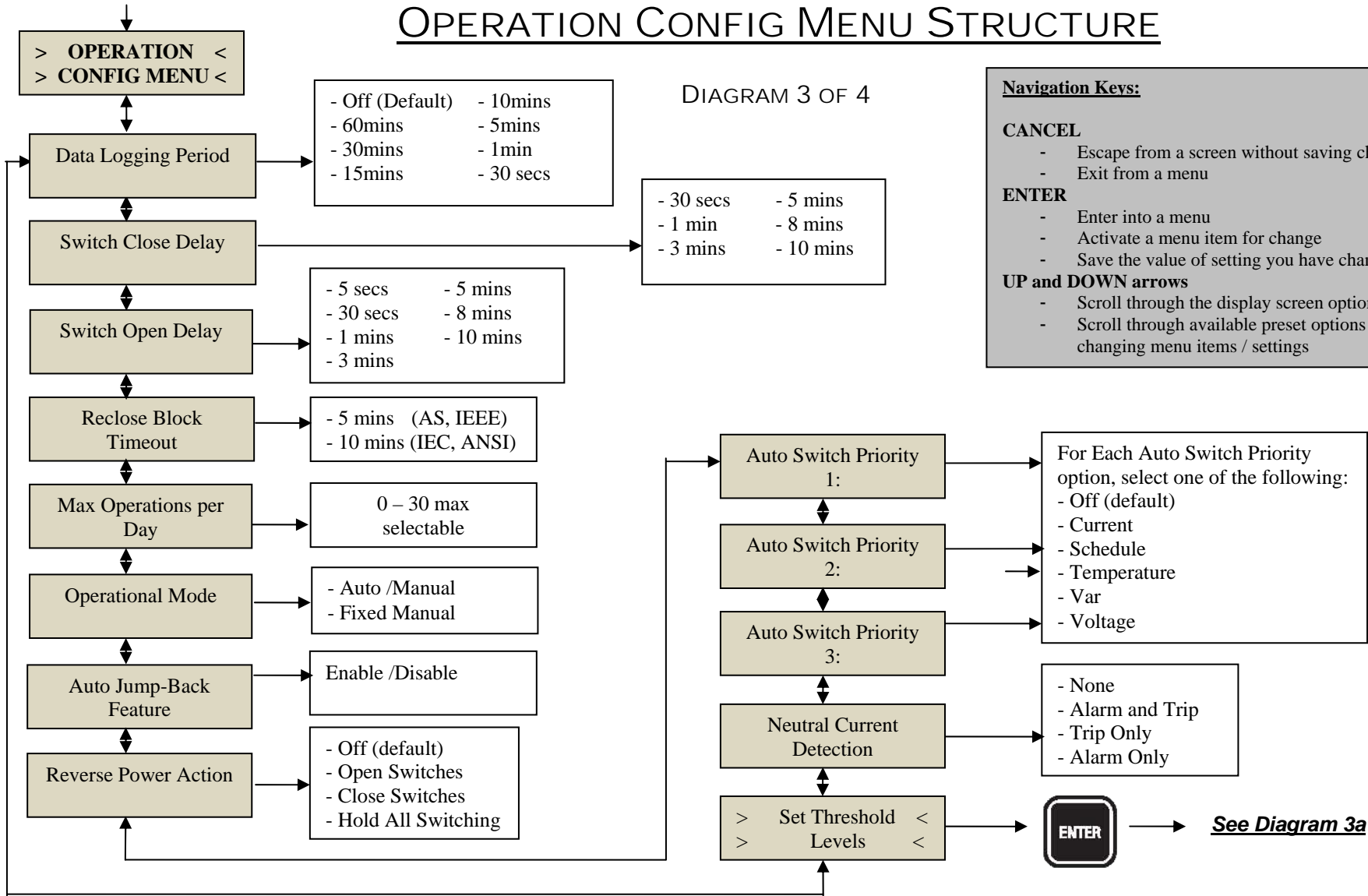

CQ900 SMART CONTROLLER

OPERATION CONFIG MENU STRUCTURE

FROM DIAGRAM 3

DIAGRAM 3A OF 4

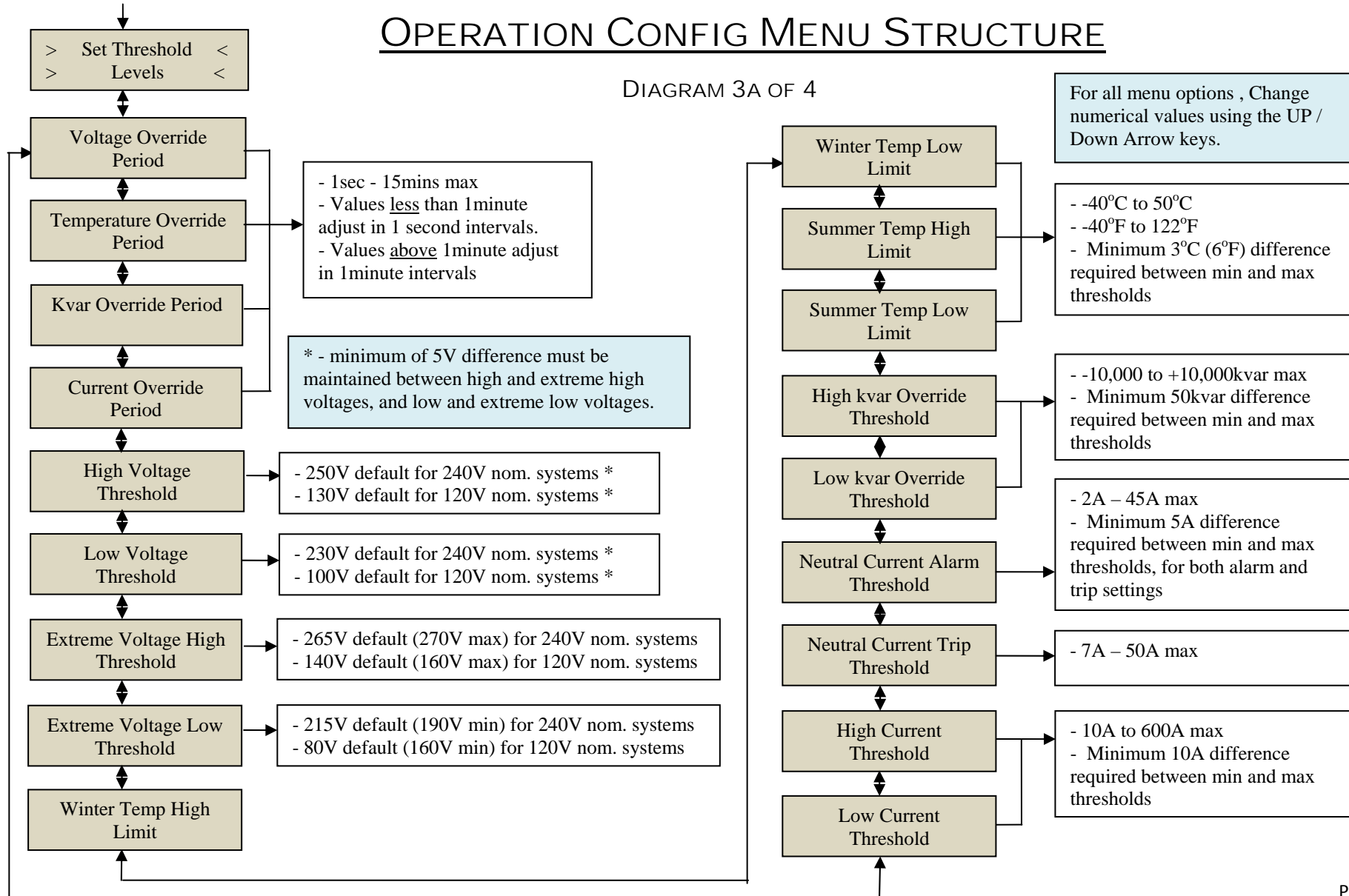

CQ900 SMART CONTROLLER

SCHEDULE CONFIG MENU STRUCTURE

FROM DIAGRAM 1

DIAGRAM 4 OF 4

