

# High Voltage Surge Arresters Buyer's Guide — Section EXLIM P

# Zinc Oxide Surge Arrester EXLIM P

Protection of switchgear, transformers and other equipment in high voltage systems against atmospheric and switching overvoltages.

- in areas with very high lightning intensity.
- where grounding or shielding conditions are poor or incomplete.
- for important installations.
- where energy requirements are very high (e.g. very long lines, capacitor protection).

**i** Other data can be ordered on request. Please contact your local sales representative.



## Brief performance data

System voltages ( $U_m$ ) 52 - 550 kV

Rated voltages ( $U_r$ ) 42 - 444 kV

Nominal discharge current (IEC) 20 kA<sub>peak</sub>

Classifying current (ANSI/IEEE) 10/15 kA<sub>peak</sub>

### Discharge current withstand strength:

High current 4/10  $\mu$ s 100 kA<sub>peak</sub>

Low current 2000  $\mu$ s 1500 A<sub>peak</sub>

### Energy capability:

Line discharge class (IEC) Class 4

[2 impulses, (IEC Cl. 8.5.5) 10.8 kJ/kV ( $U_r$ )]

Fulfills/exceeds requirements of ANSI transmission-line discharge test for 550 kV systems.

Short-circuit/Pressure relief capability 65 kA<sub>sym</sub>

External insulation Fulfills/exceeds standards

### Mechanical strength:

Specified long-term load (SLL) 7200 Nm

Specified short-term load (SSL) 18000 Nm

### Service conditions:

Ambient temperature -50 °C to +45 °C

Design altitude max. 1000 m

Frequency 15 - 62 Hz

# EXLIM P

## Guaranteed protective data 36 - 170 kV

Max. system voltage	Rated voltage	Max. continuous operating voltage <sup>1)</sup>		TOV capability <sup>2)</sup>		Max. residual voltage with current wave						
		as per IEC	as per ANSI/IEEE	1 s	10 s	30/60 μs			8/20 μs			
						U <sub>c</sub>	MCOV	1 kA	2 kA	3 kA	5 kA	10 kA
U <sub>m</sub>	U <sub>r</sub>	U <sub>c</sub>	MCOV	1 s	10 s	1 kA	2 kA	3 kA	5 kA	10 kA	20 kA	40 kA
kV <sub>rms</sub>	kV <sub>rms</sub>	kV <sub>rms</sub>	kV <sub>rms</sub>	kV <sub>rms</sub>	kV <sub>rms</sub>	kV <sub>peak</sub>	kV <sub>peak</sub>	kV <sub>peak</sub>	kV <sub>peak</sub>	kV <sub>peak</sub>	kV <sub>peak</sub>	kV <sub>peak</sub>
<b>36<sup>3)</sup></b>	30	24.0	24.4	34.8	33.0	58.5	60.7	62.2	64.9	68.3	74.8	81.9
	33	26.4	26.7	38.2	36.3	64.4	66.7	68.4	71.4	75.1	82.3	90.1
	36	28.8	29.0	41.7	39.6	70.2	72.8	74.6	77.9	81.9	89.7	98.3
	39	31.2	31.5	45.2	42.9	76.1	78.8	80.8	84.3	88.8	97.2	107
<b>52</b>	42	34	34.0	48.7	46.2	81.9	84.9	87.0	90.8	95.6	105	115
	48	38	39.0	55.6	52.8	93.6	97.0	99.4	104	110	120	132
	54	43	43.0	62.6	59.4	106	110	112	117	123	135	148
	60	48	48.0	69.6	66.0	117	122	125	130	137	150	164
<b>72</b>	54	43	43.0	62.6	59.4	106	110	112	117	123	135	148
	60	48	48.0	69.6	66.0	117	122	125	130	137	150	164
	66	53	53.4	76.5	72.6	129	134	137	143	151	165	181
	72	58	58.0	83.5	79.2	141	146	150	156	164	180	197
	75	60	60.7	87.0	82.5	147	152	156	163	171	187	205
	78	62	63.1	90.4	85.8	153	158	162	169	178	195	213
<b>100</b>	84	67	68.0	97.4	92.4	164	170	174	182	192	210	230
	90	72	72.0	104	99.0	176	182	187	195	205	225	246
	96	77	77.0	111	105	188	194	199	208	219	240	263
<b>123</b>	90	72	72.0	104	99.0	176	182	187	195	205	225	246
	96	77	77.0	111	105	188	194	199	208	219	240	263
	108	78	84.0	125	118	211	219	224	234	246	270	295
	120	78	98.0	139	132	234	243	249	260	273	299	328
	132	78	106	153	145	258	267	274	286	301	329	361
	138	78	111	160	151	270	279	286	299	314	344	377
<b>145</b>	108	86	86.0	125	118	211	219	224	234	246	270	295
	120	92	98.0	139	132	234	243	249	260	273	299	328
	132	92	106	153	145	258	267	274	286	301	329	361
	138	92	111	160	151	270	279	286	299	314	344	377
	144	92	115	167	158	281	291	299	312	328	359	394
<b>170</b>	132	106	106	153	145	258	267	274	286	301	329	361
	144	108	115	167	158	281	291	299	312	328	359	394
	150	108	121	174	165	293	304	311	325	342	374	410
	162	108	131	187	178	316	328	336	351	369	404	443
	168	108	131	194	184	328	340	348	364	383	419	459

More detailed information on the TOV capability and the protective characteristics are given in Publ. 1HSM 9543 13-01en.

1) The continuous operating voltages U<sub>c</sub> (as per IEC) and MCOV (as per ANSI) differ only due to deviations in type test procedures.

U<sub>c</sub> has to be considered only when the actual system voltage is higher than the tabulated.

Any arrester with U<sub>c</sub> higher than or equal to the actual system voltage divided by  $\sqrt{3}$  can be selected.

2) With prior duty equal to the maximum single-impulse energy stress (7.0 kJ/kV (U<sub>r</sub>)).

3) Arresters for system voltages 36 kV or below can be supplied, on request, when the order also includes arresters for higher system voltages.

Arresters with lower or higher rated voltages may be available on request for special applications.

# EXLIM P

## Guaranteed protective data 170 - 550 kV

Max. system voltage	Rated voltage	Max. continuous operating voltage <sup>1)</sup>		TOV capability <sup>2)</sup>		Max. residual voltage with current wave						
		as per IEC	as per ANSI/IEEE	1 s	10 s	30/60 µs			8/20 µs			
						U <sub>c</sub>	MCOV	1 kA	2 kA	3 kA	5 kA	10 kA
U <sub>m</sub>	U <sub>r</sub>	U <sub>c</sub>	MCOV	1 s	10 s	1 kA	2 kA	3 kA	5 kA	10 kA	20 kA	40 kA
kV <sub>rms</sub>	kV <sub>rms</sub>	kV <sub>rms</sub>	kV <sub>rms</sub>	kV <sub>rms</sub>	kV <sub>rms</sub>	kV <sub>peak</sub>	kV <sub>peak</sub>	kV <sub>peak</sub>	kV <sub>peak</sub>	kV <sub>peak</sub>	kV <sub>peak</sub>	kV <sub>peak</sub>
<b>245</b>	180	144	144	208	198	351	364	373	390	410	449	492
	192	154	154	222	211	375	388	398	415	437	479	525
	198	156	160	229	217	387	400	410	428	451	494	541
	210	156	170	243	231	410	425	435	454	478	524	574
	216	156	174	250	237	422	437	448	467	492	539	590
	219	156	177	254	240	427	443	454	474	499	546	598
	228	156	180	264	250	445	461	473	493	519	568	623
<b>300</b>	216	173	174	250	237	422	437	448	467	492	539	590
	228	182	182	264	250	445	461	473	493	519	568	623
	240	191	191	278	264	468	485	497	519	546	598	656
	258	191	209	299	283	504	522	535	558	587	643	705
	264	191	212	306	290	515	534	547	571	601	658	721
<b>362</b>	258	206	209	299	283	504	522	535	558	587	643	705
	264	211	212	306	290	515	534	547	571	601	658	721
	276	221	221	320	303	539	558	572	597	628	688	754
	288	230	230	334	316	562	582	597	623	656	718	787
<b>420</b>	330	264	267	382	363	644	667	684	714	751	823	901
	336	267	272	389	369	656	679	696	727	765	838	918
	360	267	291	417	396	702	728	746	779	819	897	983
	372	267	301	431	409	726	752	771	804	847	927	1021
	378	267	306	438	415	737	764	783	817	860	942	1037
	381	267	308	441	419	743	770	789	824	867	950	1045
	390	267	315	452	429	761	788	808	843	888	972	1070
	396	267	318	459	435	773	800	820	856	901	987	1086
	420	267	336	487	462	819	849	870	908	956	1051	1152
<b>550</b>	396	317	318	459	435	773	800	820	856	901	987	1086
	420	336	336	487	462	819	849	870	908	956	1051	1152
	444	349	353	515	488	866	897	920	960	1015	1111	1217

More detailed information on the TOV capability and the protective characteristics are given in Publ. 1HSM 9543 13-01en.

1) The continuous operating voltages U<sub>c</sub> (as per IEC) and MCOV (as per ANSI) differ only due to deviations in type test procedures.

U<sub>c</sub> has to be considered only when the actual system voltage is higher than the tabulated.

Any arrester with U<sub>c</sub> higher than or equal to the actual system voltage divided by  $\sqrt{3}$  can be selected.

2) With prior duty equal to the maximum single-impulse energy stress (7.0 kJ/kV (U<sub>T</sub>)).

Arresters with lower or higher rated voltages may be available on request for special applications.

# EXLIM P

## Technical data for housings 36 - 362 kV

Max. system voltage $U_m$	Rated voltage $U_r$	Housing	Creepage distance	External insulation				Dimensions					
				1.2/50 $\mu$ s dry $kV_{peak}$	50 Hz wet (60s) $kV_{rms}$	60 Hz wet (10s) $kV_{rms}$	250/2500 $\mu$ s wet $kV_{peak}$	Mass kg	$A_{max}$ mm	B mm	C mm	D mm	Fig.
$kV_{rms}$	$kV_{rms}$		mm	$kV_{peak}$	$kV_{rms}$	$kV_{rms}$	$kV_{peak}$	kg	mm	mm	mm	mm	
<b>36</b>	30-39	GV036	1444	318	151	135	228	85	785	-	-	-	1
<b>52</b>	42-60	GH052	1444	318	151	135	228	90	785	-	-	-	1
	42-60	GV052	3285	586	278	273	462	115	1315	-	-	-	1
<b>72</b>	54-84	GV072	3285	586	278	273	462	115	1315	-	-	-	1
<b>100</b>	84-96	GV100	3285	586	278	273	462	120	1315	-	-	-	1
<b>123</b>	90-138	GH123	3285	586	278	273	462	120	1315	-	-	-	1
	90-138	GV123	4432	774	378	359	616	150	1645	-	-	-	1
<b>145</b>	108-138	GM145	3285	586	278	273	462	120	1315	-	-	-	1
	108-120	GH145	4432	774	378	359	616	150	1645	-	-	-	1
	132-144	GH145	4432	774	378	359	616	155	1645	-	-	-	1
	108-144	GV145	4729	904	429	408	690	200	2060	-	-	-	2
<b>170</b>	132-168	GH170	4432	774	378	359	616	155	1645	-	-	-	1
	132	GV170	6570	1172	556	546	924	230	2585	800	600	400	4
	144-150	GV170	6570	1172	556	546	924	230	2585	600	-	300	3
	162-168	GV170	6570	1172	556	546	924	230	2585	-	-	-	2
<b>245</b>	180	GH245	6570	1172	556	546	924	240	2585	900	600	500	4
	192-198	GH245	6570	1172	556	546	924	240	2585	800	600	400	4
	210-228	GH245	6570	1172	556	546	924	240	2585	600	-	300	3
	180	GV245	7717	1360	656	632	1078	275	2915	1200	800	600	4
	192-198	GV245	7717	1360	656	632	1078	270	2915	900	600	500	4
	210	GV245	7717	1360	656	632	1078	270	2915	800	600	400	4
	216-228	GV245	7717	1360	656	632	1078	270	2915	600	-	300	3
	228	GM300	6570	1172	556	546	924	245	2585	900	600	500	4
<b>300</b>	240-264	GM300	6570	1172	556	546	924	245	2585	900	600	400	4
	216	GH300	7717	1360	656	632	1078	280	2915	1400	800	700	4
	228-264	GH300	7717	1360	656	632	1078	275	2915	900	600	500	4
	216	GV300	9855	1758	834	819	1386	355	3860	1600	800	1000	5
	228	GV300	9855	1758	834	819	1386	355	3860	1400	800	700	5
	240	GV300	9855	1758	834	819	1386	355	3860	1200	800	600	5
	258-264	GV300	9855	1758	834	819	1386	355	3860	1200	800	600	5
	258	GM362	7717	1360	656	632	1078	285	2915	1400	800	700	4
<b>362</b>	264-288	GM362	7717	1360	656	632	1078	285	2915	1200	800	600	4
	258-264	GH362	9855	1758	834	819	1386	360	3860	1600	800	1000	5
	276-288	GH362	9855	1758	834	819	1386	360	3860	1400	800	700	5
	258-288	GV362	12149	2134	1034	991	1694	420	4850	1600	800	1200	5

\*1 Sum of withstand voltages for empty units of arrester.

# EXLIM P

## Technical data for housings 36 - 362 kV

Max. system voltage  $U_m$  $kV_{rms}$	Rated voltage  $U_r$  $kV_{rms}$	Housing	Creepage distance  mm	External insulation *)				Dimensions					
				1.2/50 $\mu s$ dry  $kV_{peak}$	50 Hz wet (60s)  $kV_{rms}$	60 Hz wet (10s)  $kV_{rms}$	250/2500 $\mu s$ wet  $kV_{peak}$	Mass  kg	$A_{max}$  mm	B  mm	C  mm	D  mm	Fig.
<b>420</b>	330-360	GM420	8864	1548	756	718	1232	325	3245	1200	800	600	4
	330-336	GH420	11002	1946	934	905	1540	405	4190	1800	1000	1000	5
	360-372	GH420	11002	1946	934	905	1540	405	4190	1400	800	700	5
	378-420	GH420	11002	1946	934	905	1540	405	4190	1200	800	600	5
	330	GV420	13296	2322	1134	1077	1848	460	4850	1600	800	1000	5
	336-396	GV420	13296	2322	1134	1077	1848	460	4850	1600	800	1000	5
	420	GV420	13296	2322	1134	1077	1848	460	4850	1400	800	700	5
<b>550</b>	396	GM550	11002	1946	934	905	1540	425	4500	2000	1000	1200	6
	420	GM550	11002	1946	934	905	1540	420	4500	1800	1000	1000	6
	444	GM550	11002	1946	934	905	1540	420	4500	1800	1000	800	6
	396-444	GH550	14287	2352	1212	1178	2002	530	5763	2000	1000	1200	7

### Neutral-ground arresters

<b>123</b>	72-84	GN123	3285	586	278	273	462	115	1315	-	-	-	1
	90-120	GN123	3285	586	278	273	462	120	1315	-	-	-	1
<b>145</b>	84	GN145	3285	586	278	273	462	115	1315	-	-	-	1
	90-120	GN145	3285	586	278	273	462	120	1315	-	-	-	1
<b>170</b>	96-120	GN170	3285	586	278	273	462	120	1315	-	-	-	1
<b>245</b>	108-120	GN245	3285	586	278	273	462	120	1315	-	-	-	1
	132	GN245	3285	586	278	273	462	125	1315	-	-	-	1
	144	GN245	4432	774	378	359	616	155	1645	-	-	-	1

\*) Sum of withstand voltages for empty units of arrester.

# EXLIM P

Technical data for housings

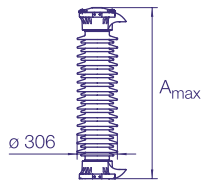

Figure 1

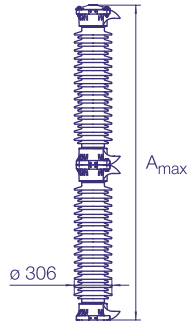

Figure 2

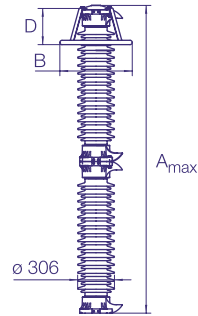

Figure 3

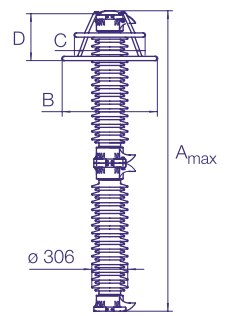

Figure 4

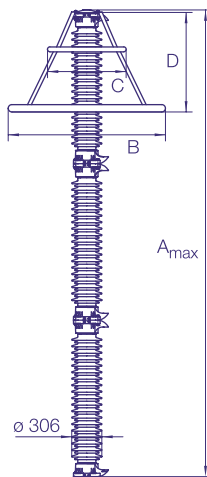

Figure 5

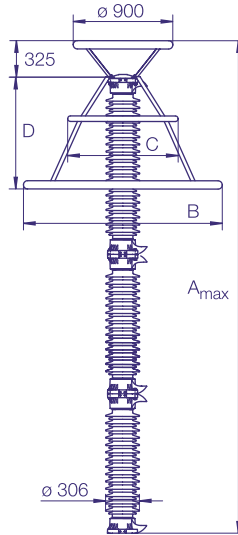

Figure 6

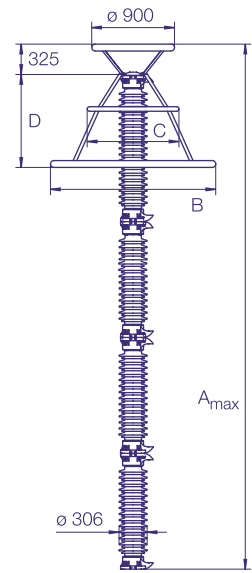
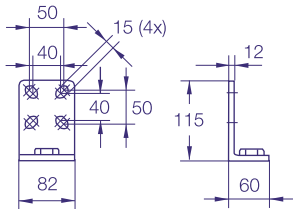

Figure 7

# EXLIM P

## Accessories

### Line terminals



**1HSA410 000-A**  
Aluminium

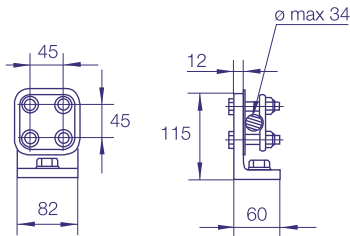

**1HSA410 000-B**  
Aluminium flag with other  
items in stainless steel

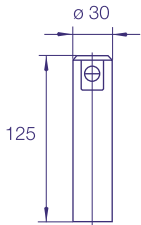

**1HSA410 000-C**  
Aluminium

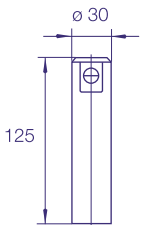

**1HSA410 000-D**  
Stainless steel

### Earth terminals

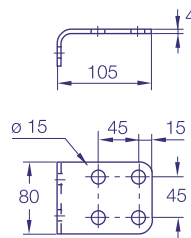

**1HSA420 000-C**  
Stainless steel

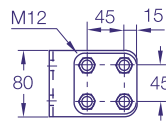
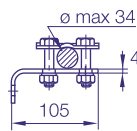

**1HSA420 000-D**  
Stainless steel

### Drilling plans

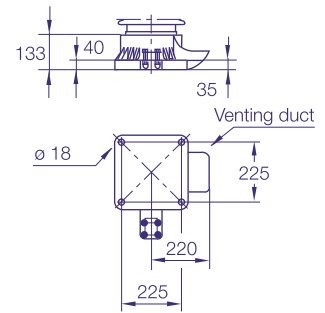

Without insulating base  
Aluminium

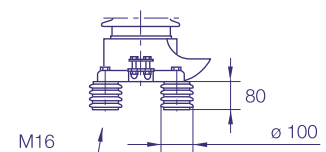
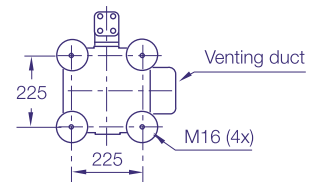

Insulating base  
**1HSA430 000-C**  
Epoxy resin

M16 bolts for connection to structure are not supplied by ABB. Required threaded grip length is 15-20 mm.

# EXLIM P

## Shipping data

Rated voltage  $U_r$  kV <sub>rms</sub>	Housing	Number of arresters per crate					
		One		Two		Three	
		Volume	Gross	Volume	Gross	Volume	Gross
		m <sup>3</sup>	kg	m <sup>3</sup>	kg	m <sup>3</sup>	kg
30-39	GV036	0.4	115	0.9	225	0.90	320
42-60	GH052	0.4	120	0.9	235	0.9	335
42-60	GV052	0.5	150	1.4	285	1.4	410
54-84	GV072	0.5	150	1.4	285	1.4	410
84-96	GV100	0.5	155	1.4	295	1.4	425
90-138	GH123	0.5	155	1.4	295	1.4	425
90-138	GV123	0.5	190	1.7	355	1.7	515
108-138	GM145	0.5	155	1.4	295	1.4	425
108-144	GH145	0.5	190	1.7	355	1.7	515
108-144	GV145	1.4	245	2.3	470	2.3	690
132-168	GH170	0.5	195	1.7	365	1.7	530
132-168	GV170	1.4	275	2.8	545	2.8	780
180-228	GH245	1.4	285	2.8	565	2.8	810
180	GV245	2.2	365	3.8	665	3.9	945
192-228	GV245	1.7	315	3.1	615	3.1	895
228-264	GM300	1.4	290	2.8	575	2.8	825
216	GH300	2.4	385	4.2	690	4.1	975
228-264	GH300	1.7	320	3.1	630	3.1	905
216	GV300	2.5	500	5.2	930	6.1	1315
228	GV300	2.1	460	5.2	890	5.2	1255
240-264	GV300	1.9	445	4.9	875	5.0	1240
258	GM362	2.4	390	4.2	705	4.1	995
264-288	GM362	2.2	375	3.8	690	3.9	985
258-264	GH362	2.5	505	5.2	940	6.1	1330
276-288	GH362	2.1	465	5.2	900	5.2	1270
258-288	GV362	3.2	565	6.3	1050	6.7	1500
330-360	GM420	2.2	410	4.1	770	4.2	1105
330-336	GH420	3.2	545	6.0	1010	6.0	1440
360-372	GH420	2.4	505	5.5	970	5.5	1375
378-420	GH420	2.2	490	3.8	960	5.3	1370
330-420	GV420	3.2	610	6.6	1150	7.0	1645
396	GM550	5.1	615	6.5	1100	6.5	1520
420-444	GM550	3.2	565	6.0	1045	6.0	1485
396-444	GH550	5.1	805	7.9	1330	7.9	1860

### Neutral-ground arresters

72-78	GN123	0.4	150	1.4	285	1.4	410
84	GNxxx	0.4	150	1.4	285	1.4	410
90-132	GNxxx	0.4	155	1.4	295	1.4	425
144	GNxxx	0.5	190	1.7	355	1.7	515

Each crate contains a certain number of arrester units and accessories for assembly and erection. A packing list is attached externally on each crate.

Each separate crate is numbered and the numbers of all crates and their contents are listed in the shipping specifica-

tion. ABB reserves the right to pack arresters in the most effective/economic combination. Alternate or non-standard crates may involve additional charges.



The table above is to be seen as an approximation and specific data for deliveries may differ from the values given.

For more information please contact:

**ABB AB**  
**High Voltage Products**  
**Surge Arresters**

SE-771 80 Ludvika, Sweden

Phone: +46 (0)240 78 20 00

Fax: +46 (0)240 179 83

E-Mail: [arresters.div@se.abb.com](mailto:arresters.div@se.abb.com)

[www.abb.com/arrestersonline](http://www.abb.com/arrestersonline)

©Copyright 2010 ABB

All rights reserved

**NOTE!** ABB AB is working continuously to improve the products. We therefore reserve the right to change designs, dimensions and data without prior notice.