

Type RJ and LCRJ bushings

Instructions for installation, maintenance, and storage

This document contains general procedures to be followed from the time bushings are received until they are put into operation.

General description

Type RJ and LCRJ bushings are applied on transformers with voltage ratings from 5 to 34 kV. The current ratings range from 300 to 23,000 amperes. Both bushings are available for cover or sidewall mounting.

A single piece, wet process porcelain shell is used as the major insulation between the conductor and the grounded mounting flange. A portion of the porcelain is coated with a metallic paint which provides a grounded connection to the mounting flange. The metal mounting flange is rolled in to formed grooves on the porcelain wall. High temperature gaskets are used to seal the mounting flange to the porcelain wall.

The 600 ampere rated bushings use a draw-lead and terminal. All bushings rated above 600 amperes are bottom connected and have a tube type conductor. For high current designs, this conductor is a copper alloy tube with end plates. Spade terminals are brazed to each end for connection to the internal transformer lead and the external line connections. A spring assembly at the lower end of the conductor tube loads the porcelain shell in compression. The spring assembly compresses the gaskets at both ends of the bushing, maintains effective sealing pressure and allows for variation in thermal expansion of the components. Figure 1 is a cutaway drawing which illustrates the bushing construction.

Typical high current RJ and LCRJ bushings feature a metalized porcelain. The partial discharge in air is minimized from the resultant shielding. A conductive coating is fired onto the external surface of the porcelain which acts as an electrostatic

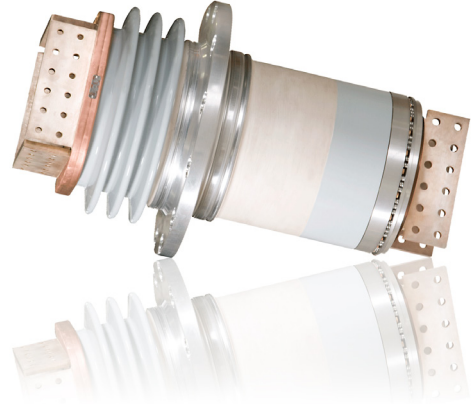

shield and prevents the concentration of electrical stresses on the edge of the bushing flange. Vertically mounted bushings usually have a seal between the central conductor and the porcelain shell at the lower end of the bushing. Small holes are drilled through the conductor tube at the upper end, which allows the processed oil from the transformer to fill the space between the conductor and the porcelain. Horizontally mounted bushings do not have this seal and the oil from the transformer is allowed to flow through the bushing for cooling and insulation.

Safety information

Keep this instruction book available to those responsible for the installation, operation, and maintenance of the bushing. The installation, maintenance, and operation of a bushing present numerous unsafe conditions, including, but not limited to, the following:

- High pressures
- Lethal voltages
- Moving machinery
- Heavy components

Specialized procedures and instructions are required, and must be adhered to, when working on such apparatus. Failure to follow instructions could result in severe personal injury, death, and/or product or property damage. Additionally, all applicable safety procedures such as OSHA requirements, regional and local safety requirements, safe working practices, and good judgment must be used by personnel when installing, operating, and maintaining such equipment.

Safety as defined in this document, involves two conditions:

- Personal injury or death
- Product or property damage (includes damage to the bushing or other property, and reduced bushing life).

Safety notations are intended to alert personnel of possible personal injury, death or property damage. They have been inserted in the instructional text prior to the step in which the condition is cited. The safety notations are headed by one of three hazard intensity levels which are defined as follows:

- Danger - immediate hazard which will result in severe personal injury, death, or property damage.
- Warning - hazard or unsafe practice which could result in severe personal injury, death, or property damage.
- Caution - hazard or unsafe practice which could result in minor personal injury, or property damage.

Receiving and unpacking

As soon as a bushing is received, open the shipping crate or box carefully, and examine the bushing for any damage incurred during shipment. If damage or rough handling is evident, file a claim with the transportation company, and notify ABB immediately.

Exercise care in opening the shipping container to prevent damage to the porcelain insulators. As each bushing is unpacked, wipe clean all dust, grease, oil or packing materials with a dry cloth. Inspect the bushing for damage such as chipped or cracked porcelain and damaged threads.

Storing

Store the bushing in a clean, dry place, preferably in an upright (oriented vertically) position in the shipping crate. Particular care should be taken to keep dust and dirt out of the inside of the bushing by wrapping the lower end spring assembly. For long term storage, suitable protection should be provided for the terminals and mounting hardware. The gasket surface on the underside of the mounting flange should be heavily greased to protect it from rust and corrosion.

Handling

Type RJ and LCRJ bushings can be lifted from the horizontal or vertical positions with a rope sling. One means of lifting is to attach a sling to a rod or bolt of suitable length that has been passed through opposite holes on the top terminal spades. Be certain to lock in or limit the rod or bolt to prevent it from slipping out. A single hitch is suitable for mounting a vertical bushing. Use a double lifting hitch to lift and mount a horizontal bushing. A bushing designed for horizontal mounting generally has a short bottom end and the center of gravity will be outward from the mounting flange. In addition to the lifting point on the terminal spades, a rope can be placed just above the mounting flange for a second lifting point. The rope sling will not damage the porcelain surfaces.

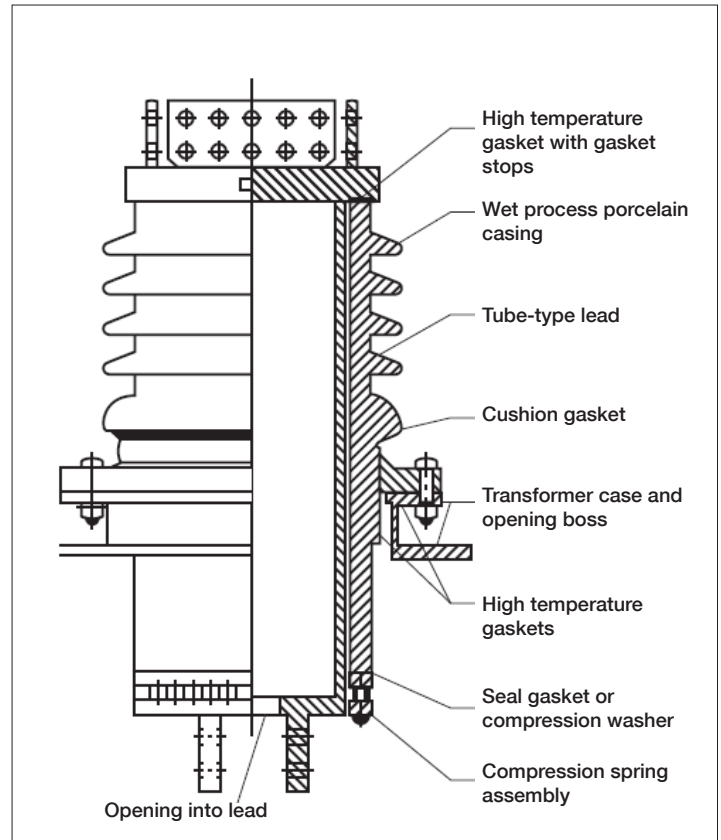

Figure 1 — LCRJ cross-section view

Installation

Type RJ and LCRJ bushings are mounted on a boss, which is welded to the transformer case. A recessed groove in the boss contains a gasket of high temperature material to seal between the bushing flange and the boss. Do not substitute low temperature gasketing material unless otherwise stipulated for a specific installation.

When installing the bushing, tighten the mounting bolts a fraction of a turn at a time, working progressively in a crisscross pattern until all of the bolts are uniformly tight. This must be done to prevent unequal clamping strain and possible damage to the porcelain support or the mounting clamp. Tighten the bolts sufficiently to seal the bushing to the mounting flange, and compress the gasket into the groove in the mounting flange.

Size of bolt (inch-thread)	Torque ft-lb (N-m)
1/2 - 13	25 (34)
5/8 - 11	30 (41)
3/4 - 10	35 (48)

Connections

It is important to fill the bushings under vacuum when the outline drawing specifies it. The low corona levels may not be achieved if this procedure is not followed.

!Caution

Before applying vacuum to a transformer, be certain there is sufficient slack in the external line connections to the bushing to allow for bushing movement caused by flexing of the transformer cover and/or walls. Failure to relieve the stress at the bushing connection may result in damage to the bushing seals and loss of oil. Loss of oil will cause an electrical failures.

The internal connections between the bushings and the apparatus to which it is installed will depend on the type of connection designed to fit the bushing. These connections must not put excessive mechanical strain on the bushing. Also, external terminal connections should be sufficiently flexible to avoid mechanical strain on the bushing. If the bushing is not a thermally upgraded bushing capable of withstanding a maximum hot spot temperature of 125 °C the terminal connectors should be ample size to keep the bushing terminal temperature below 70 °C at rated current. The use of even more generously sized connectors is recommended to minimize bushing overheating during possible overloads.

If the bushing is a thermally upgraded unit, care should be taken to ensure that the bus connecting to the top terminal of the bushing has a hot spot temperature limited to a maximum of 105 °C. This environment is typical of a bushing installed in a metal enclosed bus, e.g., the isophase bus used on the low voltage side of a GSU transformer.

Power factor

The insulation strength of the Type RJ and LCRJ bushing is achieved by the spacing between the conductor and the porcelain shell. The bushing does not have a condenser, therefore, no provision for a power factor test terminal is provided.

The power factor of the center conductor to the flange is affected by the porcelain surface condition, cleanliness, and humidity. The power factor is not necessarily indicative of the electrical strength or deterioration of the insulation properties. Visual inspection of the bushing for the cracked porcelains, cleanliness, mechanical damage, or oil leaks will give a better indication of the condition of the bushing.

Maintenance

Type RJ and LCRJ bushings are virtually maintenance free. Porcelain is the major insulation in Type RJ and LCRJ bushings, thus, requiring little maintenance other than cleaning when it is operating under contaminated conditions. Inspection should be made regularly for cracked porcelains which could contribute to oil leakage, especially on self-filling, side-wall mounted bushings or on bushings used on transformers with an oil expansion tank mounted above the cover level.

Nameplate data

Nameplate data is of special importance in answering questions about bushings. All requests will be expedited if the factory is furnished with the serial number, the functional style number, version number, and the year of manufacture as stamped on the bushing nameplate.

At a minimum, the factory should be provided with the serial number of the bushing in question.

!Caution

Do not attempt to repair a Type RJ or LCRJ bushing without specific recommendation from ABB.

Field repair

Any repair of Type RJ or LCRJ bushings should be done in the factory because of the danger of contamination to the insulation when the seal is broken. In addition, the very high vacuum and clamping pressure require the use of equipment not usually available in the field. Any damage to a bushing, which might make repair either desirable or necessary, should be reported to the factory.

For more information please contact:

ABB Inc.

1128 South Cavalier Drive
Alamo, Tennessee 38001, USA

Phone: +1 731 696 5561

Main: +1 800 955 8399

Fax: +1 731 696 5377

Email: alamo.customer_service@us.abb.com

www.abb.com/electricalcomponents

Note:

We reserve the right to make technical changes or modify the contents of this document without prior notice. The information, recommendations, description and safety notations in this document are based on our experience and judgment. This information should not be considered all inclusive or covering all contingencies. ABB does not accept any responsibility whatsoever for potential errors or possible lack of information in this document. If further information is required, ABB Inc. should be consulted.

We reserve all rights in this document and in the subject matter and illustrations contained therein. Any reproduction in whole or in parts is forbidden without prior written consent from ABB Inc.

With regard to purchase orders, the agreed particulars shall prevail. In no event will ABB Inc. be responsible to the user in contract, in tort (including negligence), strict liability or otherwise for any special, indirect, incidental, or consequential damage or loss whatsoever including but not limited to use of equipment, plant or power system, cost of capital, profits or revenues, cost of replacement power, additional expenses in the use of existing power facilities, or claims against the user by its customers resulting from the use of the information, recommendations, description and safety notations contained herein.

Copyright © 2011 ABB.
All rights reserved.