

# De-energized Tap Changer, Type DTU Application, Installation & Selection Guide

IZUA 4643-210

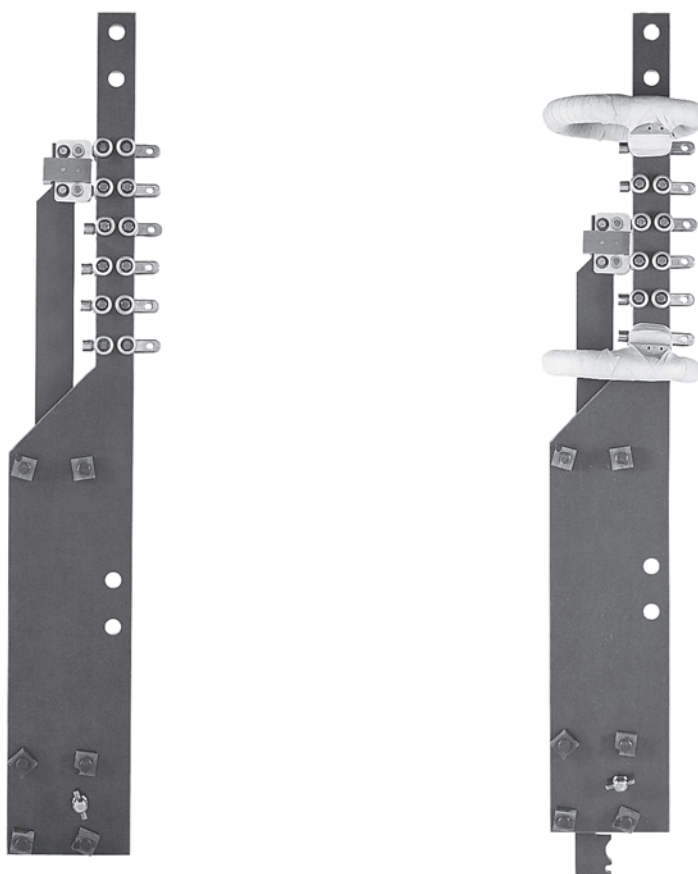

## Scope

This leaflet contains general information about ordering and installing the type DTU de-energized tap changer. These instructions do not describe all possible contingencies that may arise during installation, operation, or maintenance of the tap changer, nor does it describe all details and variations of the equipment. If you require additional information regarding this installation and the operation or maintenance of your equipment, contact the local representative of ABB.

## Safety Definitions

Safety notations are intended to alert personnel of possible personal injury, property damage, or even death. They have been inserted in this instructional text prior to the step in which the condition is cited.

The safety notations are headed by one of two hazard intensity levels, which are defined as follows:

- DANGER-** immediate hazard that will result in severe personal injury, property damage, or death.
- WARNING-** hazard or unsafe practice that could result in personal injury, property damage, or death.
- CAUTION-** hazard or unsafe practice, which could result in minor personal injury, or property damage.

## Introduction

The type DTU de-energized tap changer is one of a family of ABB tap changers for power transformers. A de-energized tap changer is a switch, which is connected to the winding taps of the transformer. When the tap changer is moved from one position to another, the amount of the tap winding connected into the circuit is changed. This permits the adjustment of the voltage ratio of the transformer to best suit the voltage requirements at the transformer's installation site. The de-energized tap changer is usually installed into the high voltage circuit of the transformer and, most of the time, it is used to adjust the primary voltage of the transformer within a 10 percent range in 5 steps.

**DANGER**

**The type DTU tap changer is a de-energized tap changer, and therefore, is designed to be operated only when the transformer is completely de-energized. This type of tap changer must not be operated when the transformer is energized. Operation when the transformer is energized is dangerous and could result in serious injury to personnel and serious damage to the transformer.**

The type DTU tap changer is a modular, bridging-type (zig-zag) tap changer with external operating mechanism. It is

most commonly available as a 5-position device. A special design of the type DTU tap changer is available which allows it to be used as a 7 position tap changer.

The type DTU tap changer is made of individual tap decks (one or two on the same housing). The DTU is designed to be mounted in the space between adjacent transformer coils and to be held in place by an insulating framework, which is attached to the transformer superstructure. Figure 1 shows a typical DTU installation.

The ability to locate the type DTU tap changer in between each phase coil, permits very direct tap lead routing with a minimum of bends.

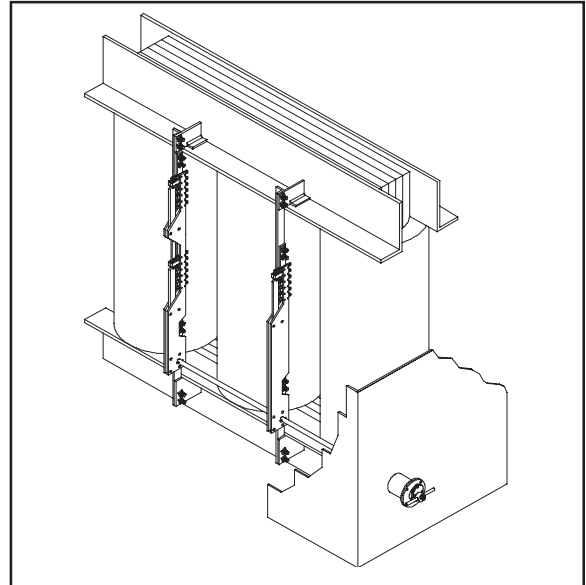

Figure 1.

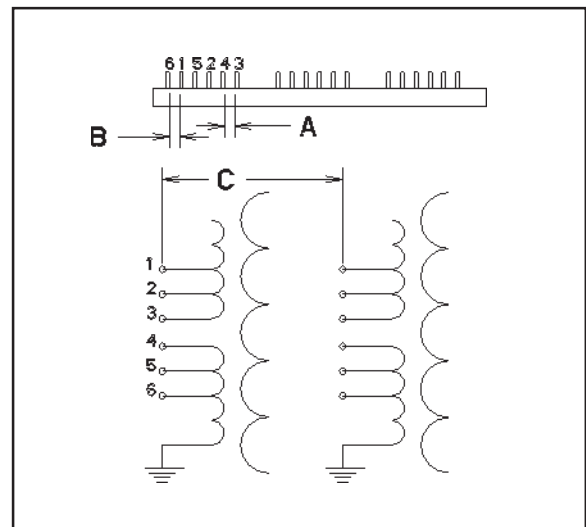

Figure 2.

## Ratings

The type DTU tap changer is available in one basic current rating, and is offered with several different electrostatic shielding and insulation options (see page 5). Table 1 presents the ratings.

Table 1. DTU Ratings		
Test/ Parameter	Rated Value	Ref. Dimension on Tap Changer
<b>Voltage Class</b>	See note <sup>3)</sup>	N/A
<b>Phase to ground and phase to phase:</b> (Values given for within the tap changer only. See note <sup>3)</sup> No shielding Lightning Impulse 60 Hz. Power Frequency Aluminum shield rings Lightning Impulse 60 Hz. Power Frequency Aluminum shield rings & Pressboard box shield Lightning Impulse 60 Hz. Power Frequency	250 kV 95 kV 350 kV 140 kV 650 kV 275 kV	N/A
<b>Between Adjacent contacts:</b> Lightning Impulse 60 Hz. Power Frequency	140 kV 50 kV	(A-B, B-C, C-D, D-E, E-F, F-A) <sup>1</sup>
<b>Short circuit current</b>	10.000A r.m.s.	N/A
<b>Rated Current<sup>2</sup></b>	500 Amps	N/A

<sup>1</sup> See Figure 2

<sup>2</sup> Based on a steady state contact temperature rise of 15°C at a continuous current equal to 120% of rated current

<sup>3</sup> This is dependant also on how the DETC is applied to the transformer, e.g. distance to the tank wall and distance between phases. See also Electrostatic Shielding and Insulation (page 5)

## Construction Details and Features

### Basic Information

The type DTU, de-energized tap changer is constructed from five major components:

1. Main Housing
2. Sliding Rack
3. Moving Contact
4. Stationary Contacts
5. Drive Shaft and External Operating Mechanism

Figure 3 shows the first four major components and some mounting details.

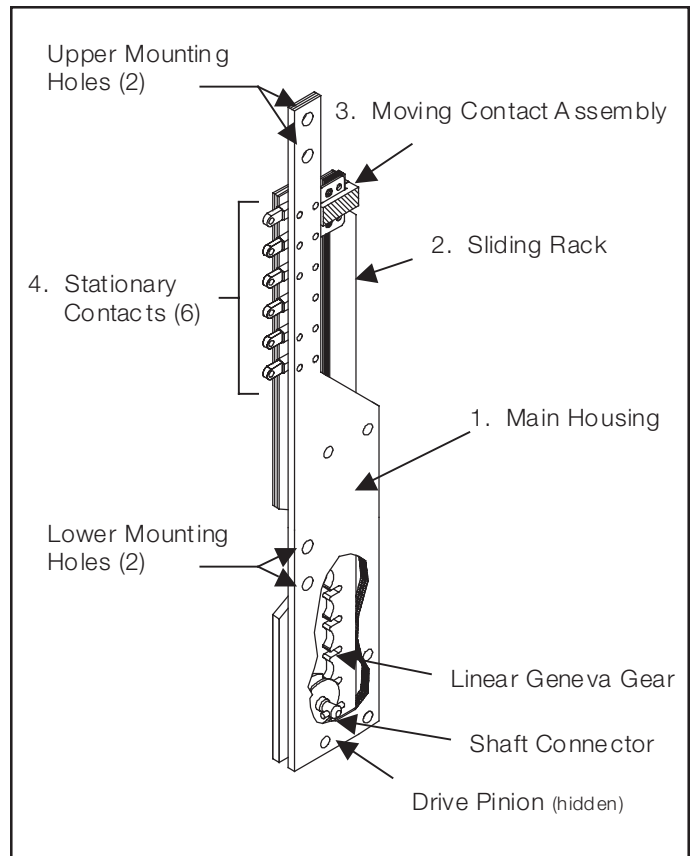

Figure 3. Major components of the DTU tap changer

## Main Housing

The main housing consists of two flat insulating plates fastened together with insulating bolts and spacers to form a sandwich-like structure. The stationary contacts are bolted to the main housing at its upper end and the driving gear pinion and shaft connector are attached at its lower end. The main housing contains two sets of holes which are used to bolt the tap changer to the transformer framework. The flat insulating plates are machined from high strength, electrical grade, low power factor Micarta™. This structure carries all of the mechanical loads created by the weight of the tap leads and the thrust and weight of the drive shafts.

## Sliding Rack

The sliding rack rides in the space between the two main housing plates. The moving contacts are attached to the sliding rack at its top end. The bottom end of the sliding rack is machined into a linear Geneva gear which is moved vertically by the rotary action of the drive pinion. One full turn of the drive pinion moves the sliding rack from one set of stationary contacts to the next. The sliding rack is machined from the same Micarta™ material as the main housing plates.

## Contacts

The stationary contacts are machined from 3/4 of an inch (19 mm) copper bar stock. These contacts are bolted between two Micarta™ plates of the main housing. Two bolts are used for each contact. The bolt heads and nuts are shielded with special toroidially shaped washers to minimize electrical stress concentration. The connection between the stationary contacts and the transformer's tap leads is made using the standard ABB UZ tap changer cable lug (see UZ technical guide 1ZSE 5492-104). This lug accepts the tap cable into a tubular recess; the cable can be held in place by either crimping or brazing to the lug. The other end of the lug contains a captive steel, M10 (0.40 inch) bolt with a hex recess. The cable lug attaches to the stationary contact by means of this bolt, which is threaded into a tapped cross-hole on the end of the stationary contact. The cable lug is available in several sizes to suit the tap cable diameter.

The moving contact assembly is a clam shell type of contact; the spring loaded contact plates slide over the stationary contacts. Each contact plate is made from silver plated copper flat stock. Two pairs of springs precisely control contact pressure. These springs are designed to interact with the contact plates and the support structure to provide uniform and consistent contact pressure. The moving contact assembly also contains an external magnetic yoke. The purpose of this yoke is to generate additional compression forces on the contact structure during high currents created by through faults or surges. The combination of clam shell contact and magnetic yoke creates a contact system which generates large compression forces during faults, yet allows lighter contact forces during normal operation. This feature permits the tap changer to have a relatively low driving torque

and high fault current withstand capability by preventing contact bounce and arcing during faults.

The action of the sliding contact over the moving contact during a tap change creates a good wiping action that cleans contact surfaces. This wiping action insures a solid, low resistance electrical connection. Details of the contact system can be seen in figure 4.

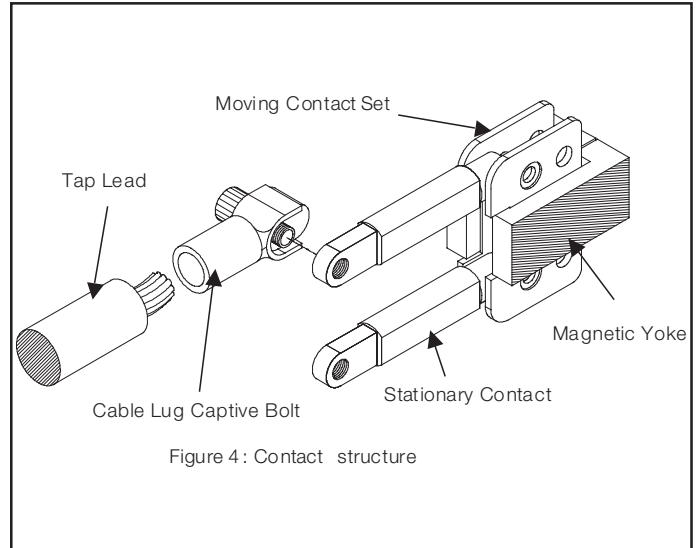

Figure 4. Contact Structure

## Driving System

The drive system consists of four parts:

1. Linear Geneva gear
2. Drive pinion
3. Interphase shafts (insulating material)
4. Main drive shaft and external mechanism

These parts are illustrated in figure 5.

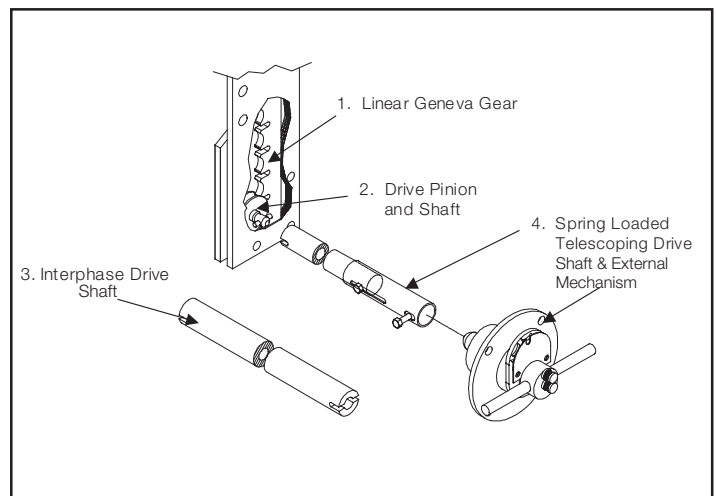

Figure 5. Drive System

The linear Geneva gear is machined into the sliding rack that carries the sliding contacts. The drive gear pinion is installed between the two main plates such that the drive pinion engages the linear Geneva gear.

The interphase shafts are steel tubes that are attached to the drive pinion with a slotted cross pin connection. Both ends of each interphase shaft act as slip joint connections. The main drive shaft is a spring loaded, telescoping tube assembly. This assembly connects the first tap deck drive pinion to the ball joint coupling on the inner end of the operating mechanism.

The combination of slotted interphase shaft connections and spring loaded telescoping drive tube allows for minor misalignments between tap changer components and permits the shafts and operating mechanism to adjust to the dimensional changes that occur as the transformer responds to temperature variations.

The operating mechanism uses a packing gland backed up by a secondary o-ring to form a redundant shaft seal between the transformer and the atmosphere. The flange of the operating mechanism is gasketed and bolted to a mounting boss which is welded to the transformer tank.

The external operating mechanism drives the tap changer's operating shafts so that one complete revolution of the external handle indexes each tap deck one position. This one-turn-per-tap action allows the driving mechanism system to absorb any backlash in the entire tap changer structure and still provide precise positioning of the tap changer contacts.

To make a tap change the operator must perform two separate actions:

1. Pull a fixing pin which frees the mechanism shaft
2. Turn the operating handle 360 degrees

A number on a Geneva wheel that is visible through a view-port indicates the position number. A position number is only fully visible when the tap changer is in position. The fixing pin will not re-seat itself unless the tap changer is fixed on a position. Positive mechanical stops are built into the tap changing mechanism that will prevent turning past the lowest and highest positions. The external mechanism can be padlocked in any position.

### Electrostatic Shielding and Insulation

Electrical spacing requirements between the tap decks and the tank wall and between the tap decks and adjacent phases or other metallic objects is a complex subject. When designing the transformer, required distances should be calculated between phases and between phase and ground for the DTU. Three levels of shielding and insulation are available for the tap decks.

1. Unshielded decks are typically used for applications that have an impulse voltage withstand requirement of 250 kV or less.
2. For applications that require an impulse voltage withstand of 350 kV or less, a cast aluminum electrostatic shield ring is bolted to each end of the tap deck. The ring portion of each shield is insulated with layers of paper tape.
3. For applications requiring an impulse withstand greater than 350 kV and up to 650 kV, a pressboard box shield is added to the tap deck. This box shield extends between the upper and lower aluminum shield ring.

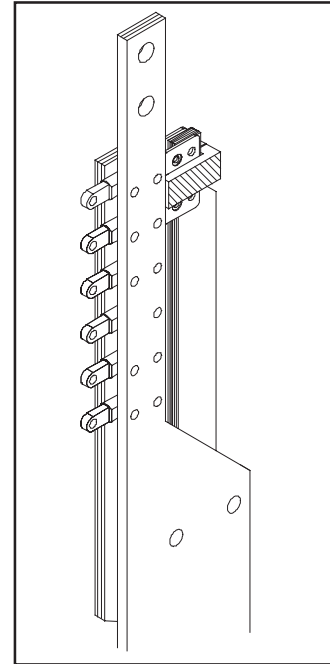

**Figure 6. DTU tap deck with no shielding**

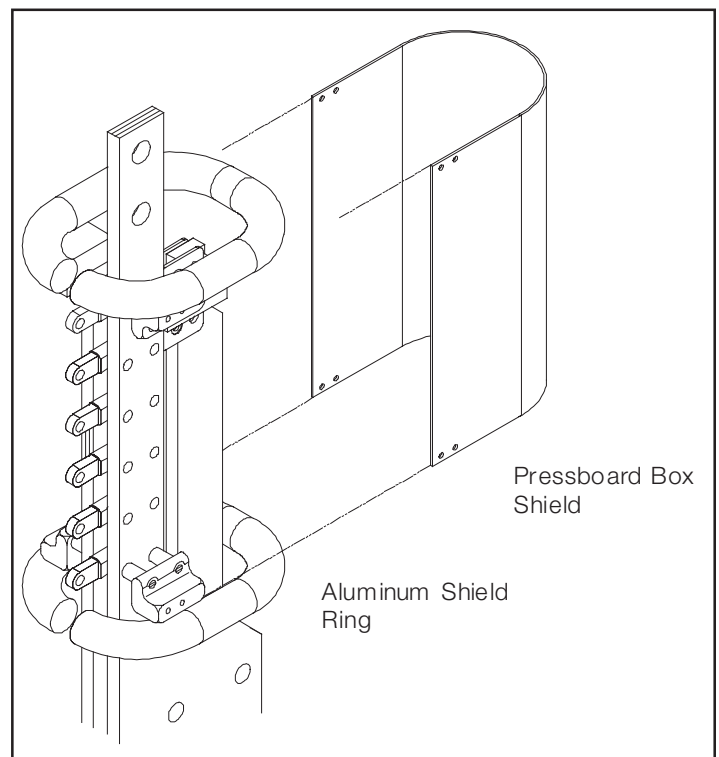

**Figure 7. DTU tap deck with shielding options**

## Standard Configurations

The type DTU tap changer is built in three standard configurations based on vertical tap decks. The operating mechanism may be ordered for mounting on either the left or right hand side of the tap decks. An ordering data sheet is provided to permit the customer to specify configuration, mechanism location, critical spacing dimensions, and crimp lug sizes.

**Configuration A:** One vertically mounted, single tap deck and one vertically mounted double tap deck (three tap decks total). The two vertical units are connected by an interphase drive shaft. One of the vertical decks is also connected to the external operating mechanism.

**Configuration B:** Three vertically mounted single tap decks (three tap decks total). The vertical units are connected together by interphase shafts (two). One of the vertical decks is also connected to the external operating mechanism.

**Configuration C:** Three vertically mounted double tap decks (six tap decks total). The vertical units are connected together by interphase shafts (two). One of the vertical decks is also connected to the external operating mechanism.

These configurations are shown in figure 9.

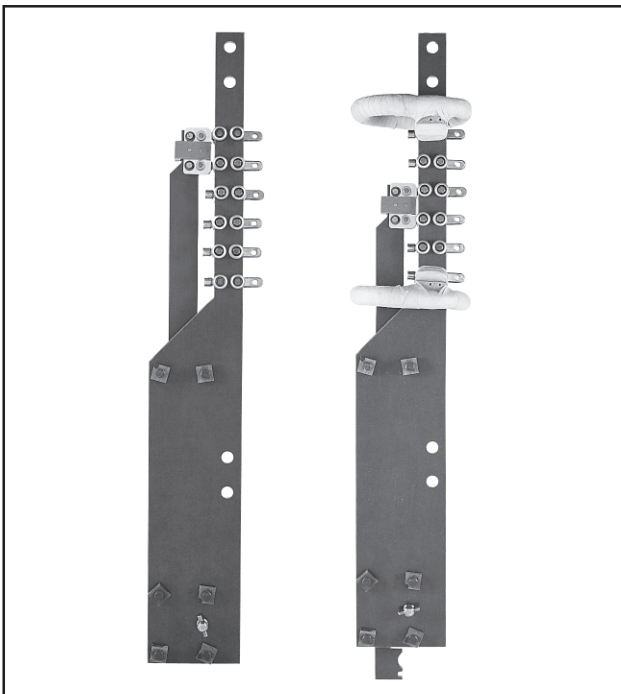
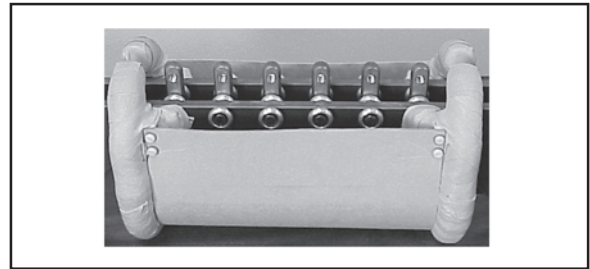

Figure 8. DTU tap deck shielding options

Left: DTU tap changer with no shielding  
Right: DTU tap changer with aluminum ring shields



Above: DTU tap changer with aluminum ring shields and pressboard box

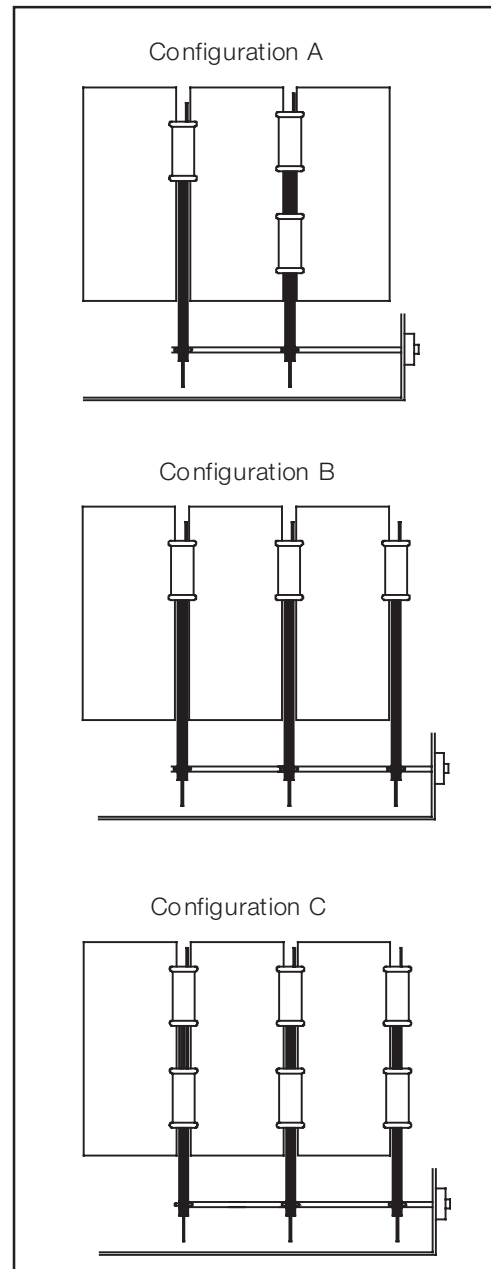
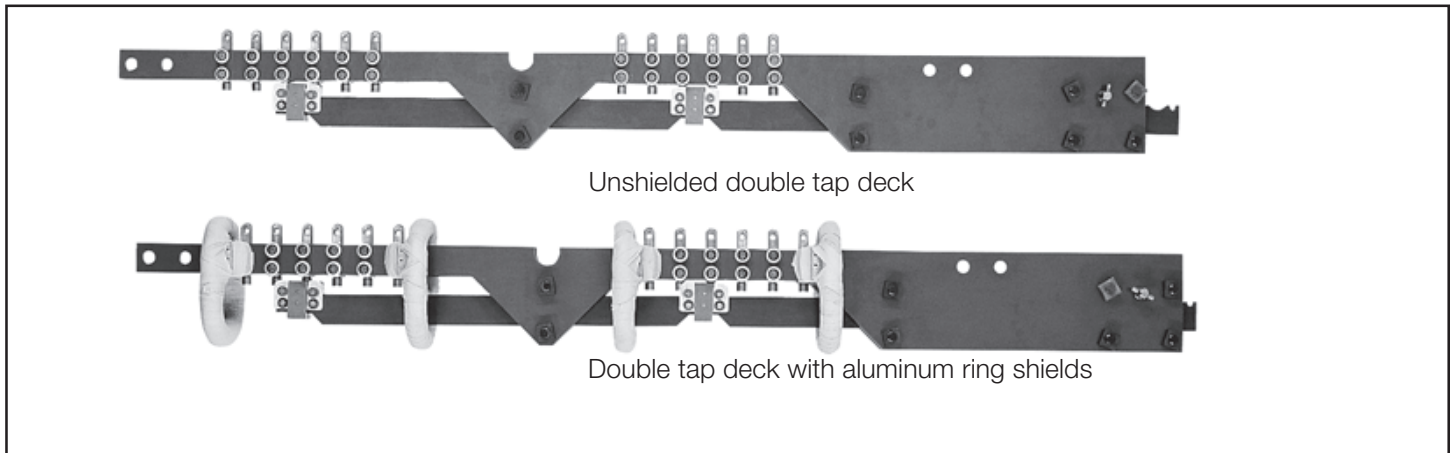

Figure 9. Standard configurations for DTU tap changer



**Figure 10. DTU double tap decks**

## Installation and Mounting

### Inspection Upon Receiving

- Check for visible damage.
- All DTU tap changers are shipped with moving contacts in the same position. Please check to verify that the moving contacts are indeed in the same position before continuing.
- Verify that the shipment is complete and contains all components ordered.
- Check that the type designation and shop order number agree with the delivery documents (i.e. the packing list or ABB's ordering acknowledgement). The shop order number is stamped on the rating plate.

### Required Tools and Materials

Only Standard tools are required.

### Pre-Installation Work Required by Customer

- Make the appropriate size hole in the transformer tank according to the dimensions shown in the tap changer outline drawing.
- Weld mounting boss (not supplied by ABB) to the transformer wall. This weld must be gas tight.
- Prepare the superstructure with holes for the assembly of each DTU deck.

The DTU is usually mounted vertically, parallel to the windings,. The information that follows is intended for this type of installation. If some other orientation is being considered, please consult ABB.

The type DTU tap changer requires a support structure constructed of appropriate insulating materials to secure the tap changer decks vertically. This structure, which is part of the transformer design, usually also supports the HV cleats and leads. Clearance must be provided for the tap changer shaft operating system that is located at the lower end of the deck frames.

Refer to the DTU dimension drawings for complete mounting details.

Installation of tap changer decks:

1. Make sure that all decks are in the same position.

2. Install the first deck with fiber bolts through the two mounting holes at the top and bottom ends.
3. To mount the second deck, insert one fiber bolt at the top to loosely hold it in place.
4. Install the operating shaft between the first and second decks by inserting the slotted ends onto the drive pinions located at the lower end of the two decks. No drilling or pinning is required. Install the remaining fiber bolts and tighten.
5. Repeat this process for the third deck.
6. To confirm that the installation has been done correctly, turn the operating shaft and observe the movement of the bridging contacts. All three phases should move together smoothly from one end to the other.
7. The operating shaft between the outside deck, left or right end depending on what was ordered, and the external operating mechanism is installed after the active part has been installed in the tank. This shaft is spring loaded to provide some flexibility in the length to compensate for the expansion and contraction of the transformer tank during operation.
8. Connecting tap leads:
 

Cut tap leads to the correct length for connection to the appropriate tap changer terminal. Crimp the supplied connectors to the tap leads. Connect the tap leads to the correct tap changer terminal.
9. Installation Tip:
 

To ease the installation of the tap changer, it is recommended to make up a replica of the tap changer and the connection points. This replica can be installed in the place of the tap changer deck plates, allowing the tap leads and insulation to be cut to the proper length and installed without risk of damaging the tap changer. After the tap leads have been fully assembled on the replica, undo the connectors, remove the replica and then install the tap changer in its place.

## External Mounting Boss

An external mounting boss must be fabricated and welded to the transformer tank in order to seat the operating mechanism. This mounting boss may be purchased from ABB if desired.

## Processing Temperatures

The type DTU tap changer is designed to operate properly in the transformer environment. However, the transformer manufacturer must not thermally over-stress the tap changer during transformer manufacturing and processing. The maximum temperature that the DTU tap changer can be exposed to during transformer manufacturing is 125°C. If the tap changer will be exposed to temperatures greater than 125°C during manufacture, ABB should be consulted for technical guidance. Processing within the temperature range of 105°C to 125°C should not exceed 48 hours total exposure time.

## Renewal Parts

If renewal parts are required, order them through the nearest ABB Inc. representative. Please provide the item description and the identification numbers (model, style, catalog) from the unit's nameplate.

## Repairs

In normal use, the DTU tap changer will not require repairs. We recommend that the transformer manufacturer be contacted before any repairs are made.

## Maintenance

ABB de-energized tap changers require little or no maintenance to ensure proper mechanical and electrical operation of the switch. The transformer should be de-energized before operating the tap changer. The external operating mechanism should be inspected for any damage and gears should be lubricated to ensure proper operation. Operate the tap changer across its full range a minimum of twenty times to assure proper mechanical operation and cleaning of the contacts. The above should be performed if the position of the switch is changed for any reason.

# WARNING

**BEFORE ATTEMPTING ANY DISASSEMBLY OR REPAIRS, DE-ENERGIZE THE TRANSFORMER AND THE AUXILIARY POWER SOURCE. FAILURE TO DO SO COULD RESULT IN PERSONAL INJURY, PROPERTY DAMAGE, OR DEATH.**

## Technical Support

If a technical question arises regarding the product detailed in this Technical Product Literature contact customer service at the address below.

## Comments

ABB Inc. continually strives to make its instruction literature current, accurate, and easy to understand. Suggestions to improve this document may be sent to: Literature Coordinator fax (731) 696-5269 or use the mailing address below. For a reply, please include name, company, phone number, and/or fax number.







## DISCLAIMER OF WARRANTIES AND LIMITATION OF LIABILITY

**THERE ARE NO UNDERSTANDINGS, AGREEMENTS, REPRESENTATIONS OR WARRANTIES, EXPRESSED OR IMPLIED, INCLUDING WARRANTIES OF MERCHANTABILITY OR FITNESS FOR A PARTICULAR PURPOSE OTHER THAN THOSE SPECIFICALLY SET OUT BY AN EXISTING CONTRACT BETWEEN THE PARTIES. ANY SUCH CONTRACT STATES THE ENTIRE OBLIGATION OF SELLER. THE CONTENTS OF THIS DOCUMENT SHALL NOT BECOME PART OF OR MODIFY ANY PRIOR OR EXISTING AGREEMENT, COMMITMENT OR RELATIONSHIP.**

THE INFORMATION, RECOMMENDATIONS, DESCRIPTION AND SAFETY NOTATIONS IN THIS DOCUMENT ARE BASED ON OUR EXPERIENCE AND JUDGEMENT. **THIS INFORMATION SHOULD NOT BE CONSIDERED TO BE ALL INCLUSIVE OR COVERING ALL CONTINGENCIES.** IF FURTHER INFORMATION IS REQUIRED, ABB INC. SHOULD BE CONSULTED.

**NO WARRANTIES, EXPRESSED OR IMPLIED, INCLUDING WARRANTIES OF FITNESS FOR A PARTICULAR PURPOSE OR MERCHANTABILITY, OR WARRANTIES ARISING FROM COURSE OF DEALING OR USAGE OF TRADE, ARE MADE REGARDING THE INFORMATION, RECOMMENDATIONS, DESCRIPTIONS, AND SAFETY NOTATIONS CONTAINED HEREIN.** IN NO EVENT WILL ABB INC. BE RESPONSIBLE TO THE USER IN CONTRACT, IN TORT (INCLUDING NEGLIGENCE), STRICT LIABILITY OR OTHERWISE FOR ANY SPECIAL, INDIRECT, INCIDENTAL, OR CONSEQUENTIAL DAMAGE OR LOSS WHATSOEVER INCLUDING BUT NOT LIMITED TO DAMAGE TO OR LOSS OR USE OF EQUIPMENT, PLANT OR POWER SYSTEM, COST OF CAPITAL, LOSS OF PROFITS OR REVENUES, COST OF REPLACEMENT POWER, ADDITIONAL EXPENSES IN THE USE OF EXISTING POWER FACILITIES, OR CLAIMS AGAINST THE USER BY ITS CUSTOMERS RESULTING FROM THE USE OF THE INFORMATION, RECOMMENDATIONS, DESCRIPTION, AND SAFETY NOTATIONS CONTAINED HEREIN.



ABB Inc.  
1128 S. Cavalier Drive  
Alamo, TN 38001, USA  
Telephone: 731-696-5561  
Fax: 731-696-5269  
[www.abb.com/electricalcomponents](http://www.abb.com/electricalcomponents)