

Type T bushing

Instructions for installation, maintenance, and storage

This document describes the application recommendations as well as installation and maintenance guidelines for the Type T bushing.

General information

The Type T condenser bushing is available as both a high temperature design and as a standard design. The high temperature design is thermally enhanced to operate properly when the bushing is applied inside of the high temperature environment of non-ventilated bus duct. The Type T bushing meets the requirements of the appropriate IEEE standards. Type T bushings are available for both cover and side-wall mounting in current ratings from 400 to 21,500 amperes, and voltage ratings from 25 to 46 kV.

The Type T bushing has a condenser consisting of oil-impregnated paper (or Nomex™ when the bushing is a high temperature design) wound on a central conductor. The condenser provides uniform distribution of electrical stresses and prevents damaging stress concentrations. The condenser is immersed in high quality transformer oil contained inside of the center-clamped and gasketed structure, which is the outer shell of the bushing. Sufficient clamping pressure is applied at the factory to maintain a sealed housing for the condenser, its insulating oil, and the gas cushion above the oil.

Safety information

Keep this document available to those responsible for the installation, operation, and maintenance of the bushing. The installation, operation, and maintenance of a bushing presents numerous potential unsafe conditions, including, but not limited to, the following:

- High pressures
- Lethal voltages
- Moving machinery
- Heavy components

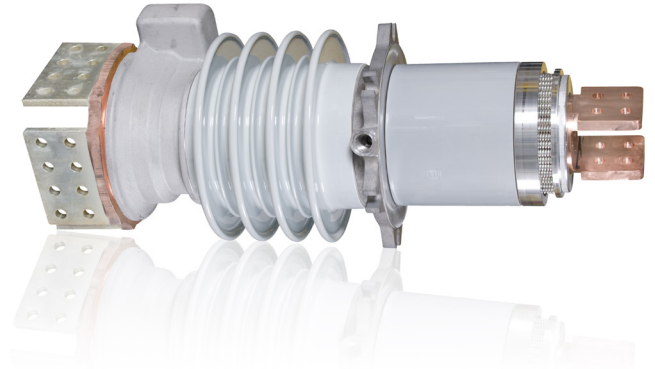

Specialized procedures and instructions are required and must be adhered to when working on such apparatus. Failure to follow instructions could result in severe personal injury, death and/or product or property damage. Additionally, all applicable safety procedures such as OSHA requirements, regional and local safety requirements, safe working practices, and good judgment must be used by personnel when installing, operating and/or maintaining such equipment. Safety, as defined in this document, involves two conditions:

- Personal injury or death.
- Product or property damage (includes damage to the bushing or other property, and reduced bushing life).

Safety notations are intended to alert personnel of possible personal injury, death and/or property damage. They have been inserted in the instructional text prior to the step in which the condition is cited. The safety notations are headed by one of three hazard intensity levels, which are defined as follows:

- Danger - immediate hazard, which will result in serious personal injury, death and/or property damage.
- Warning - hazard or unsafe practice which could result in severe personal injury, death and/or property damage.
- Caution - hazard or unsafe practice, which could result in minor personal injury, or property damage.

Receiving

ABB ships the bushing ready for installation. Open the box or shipping crate carefully to avoid damaging the bushing. Examine the bushing as soon as you receive it for shipping damage. If there is any visible damage, file a claim with the transportation company and notify ABB immediately.

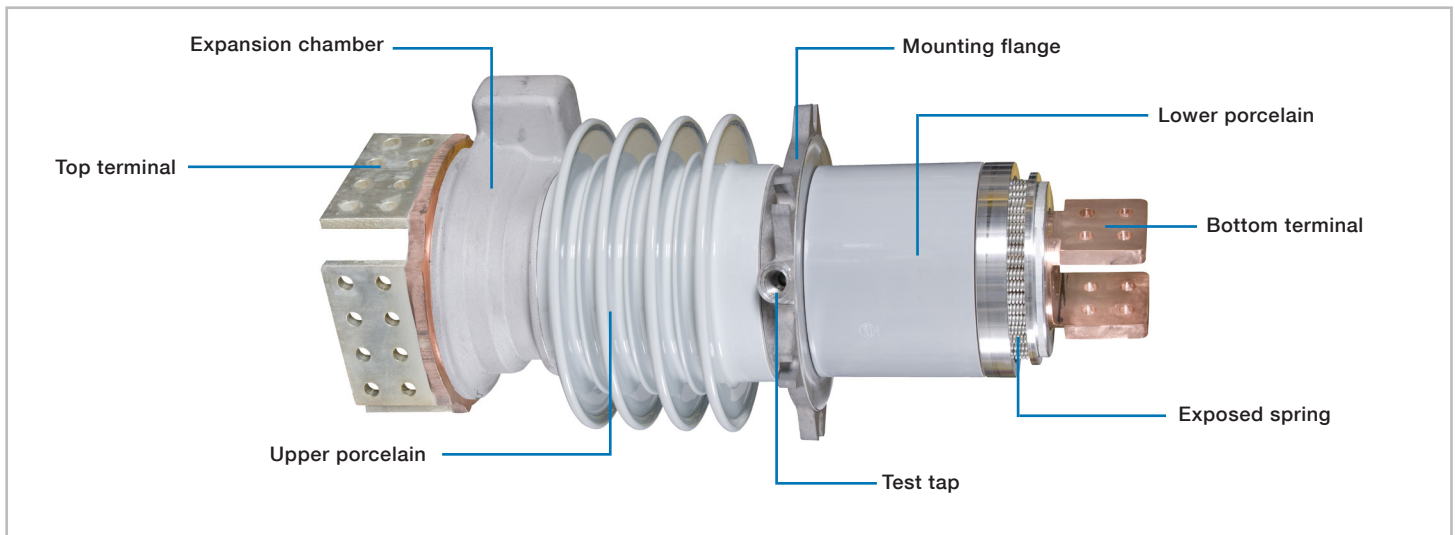

Figure 1 — Type T vertical or horizontal bushing

Wipe the porcelains clean and examine them for small breaks or hairline cracks, which might cause oil leakage later. Examine the bushing for evidence of oil leakage. Surface oil is carefully removed from the bushing after the factory electrical tests. However, a bushing may occasionally show evidence of an oil film when received. While this is cause for concern, the following should be considered:

- The Type T bushing is oil pressure tested at a minimum of 22-psi for 6-hours according to IEEE standard C57.19.00 prior to shipment.
- An oil film on surfaces or joints could be residual from the factory electrical tests, which are performed with part of the bushing under oil.
- Hidden damage can permit oil leakage. Wipe all surfaces and gasketed joints clean and dry, and monitor any oil leakage for 48 hours.

Storage

Store the Type T bushing in a clean and dry place. Provide suitable protection for terminals, mounting hardware, and spring assembly to prevent corrosion. Particular care should be provided to the spring assembly if the bushing will be subject to long term storage. Store a vertically mounted bushing in an upright position. Store a horizontally mounted bushing in a horizontal position with the oil expansion chamber in the 12 o'clock position.

Handling

The Type T bushing can be lifted from the horizontal or vertical position by the use of a rope sling. One means of lifting is to attach a sling to a 0.625-inch diameter rod or bolt of a suitable length to pass through opposite holes of the top terminal blades. Be sure to lock-in, or limit the rod or bolt to prevent it from slipping out. This single hitch is suitable for mounting a vertical bushing. Two hitches or a double lifting hitch must be used to mount a horizontal bushing. A bushing designed for horizontal mounting has a short bottom end; therefore,

the center-of-gravity is outward from the mounting flange. In addition to the lifting point at the blades, a rope can be placed around the porcelain just outward of the flange at the first shed to provide a second lift point. The rope sling will not abrade the porcelain surface. Keep the top end above the horizontal axis of the bushing.

Cleaning

Before installing the bushing, wipe the porcelains with a clean cloth to remove dust and dirt, which may have accumulated during transit and storage. Any contamination on the bushing porcelain or flange can result in erroneous power factor or capacitance readings.

Mounting

When mounting a Type T bushing, follow the handling recommendations previously described for lifting the bushing into position. A sidewall-mounted bushing should be moved slowly from a vertical to a horizontal position, always keeping the top terminal at or above the horizontal axis. Set the bushing into position slowly, being careful to clear the internal apparatus structure. If the bushing has an expansion chamber (see Figure 1), it must be mounted with the expansion chamber located at the 12 o'clock position (top dead center).

Bolting

Tighten the mounting bolts a fraction of a turn at a time, working progressively in a crisscross pattern until all bolts are uniformly tight. Tighten only sufficiently to seal the bushing to the transformer. The torque values listed below will provide adequate gasket compression for sealing.

Size of bolt (inch-thread)	Torque ft-lbf (N-m)
1/2 - 13	25 (34)
5/8 - 11	30 (41)
3/4 - 10	35 (48)

Power factor measurement

The test tap outlet shown in Figure 1 is located above the mounting flange. The outlet provides a convenient means for making power factor measurements by the ungrounded specimen test (UST) method. In order to measure power factor, remove the threaded cap and connect the measuring lead of the testing equipment to the terminal spring. After testing has been completed, reassemble the threaded cap to ground the test tap for proper operation of the bushing.

Many bushing users measure the UST power factor at the time of bushing installation. ABB endorses this practice and it is discussed in more detail in the Maintenance section.

!Caution

Before applying vacuum to a transformer, be certain there is sufficient slack in the external line connections to the bushing to allow for bushing movement caused by flexing of the transformer cover and/or walls. Failure to relieve this stress at the bushing connection may result in damage to the bushing seals and loss of oil. Loss of oil will cause an electrical failure.

Connections

The internal connections between the bushing and the transformer will depend on the type of connection designed to fit the bushing. These connections must not put excessive mechanical strain on the bushing. In addition, external terminal connections should be sufficiently flexible to avoid mechanical strain on the bushing. Terminal connectors should be of ample size to keep the bushing's terminal temperature below 70 °C at rated current. The use of even more generously sized connectors is recommended to minimize bushing overheating during possible overloads.

Oil fill level

The oil level in the Type T bushing is adjusted at the factory to the normal level at approximately 25 °C. Unless there is subsequent mechanical damage to the bushing, which results in the loss of oil, the oil level should be satisfactory for the life of the bushing. Since fluctuations in oil level will occur with changing temperature, the oil in the bushing is topped with a compressible cushion of dry nitrogen gas to fill any space left by a varying volume of oil.

Nameplate data

Nameplate data can be of special importance in answering questions about bushings. Requests will be expedited if the serial number, the style number or the catalog number, and the year of manufacture (as stamped on the nameplate) are furnished at the time of inquiry.

The style number identifies the bushing by type and rating. The style number will include a version designation, i.e. VER 1, VER 2. The version number is significant only to the factory because

it indicates minor design changes. Bushings with the same style number are interchangeable regardless of the version number.

Maintenance

Type T bushings require little or no maintenance other than a periodic cleaning. ABB does recommend the periodic measurement of the UST power factor. Bushings exposed to salt spray, cement dust, and other abnormal deposits are subject to special contamination related hazards and must be cleaned regularly to prevent flashover and corrosion of parts. Since service interruptions can result from bushing outages, many users have programs of planned preventive maintenance. ABB endorses such programs and recommends the following:

- Measurement of UST power factor and capacitance at installation. This gives a good benchmark for comparison with future readings. It also correlates field and factory measurements.
- Continued power factor and capacitance readings at periodic intervals based on the importance of the installation and the trend of the data accumulated on a bushing.
- A steadily increasing trend in UST power factor or capacitance is cause for concern.

Contact your ABB sales representative for corrective action procedures if the power factor doubles from the original installation value or the capacitance increases to 110 percent of the original installation value.

Field repair

Do not attempt to repair a Type T busing without specific recommendations from ABB. Any repair of the Type T bushing should be done at the factory because of the danger of contamination to the insulation. In addition, the very high vacuum and clamping pressure require the use of equipment not usually available in a service shop.

For more information please contact:

ABB Inc.

1128 South Cavalier Drive
Alamo, Tennessee 38001, USA

Phone: +1 731 696 5561

Main: +1 800 955 8399

Fax: +1 731 696 5377

Email: alamo.customer_service@us.abb.com

www.abb.com/electricalcomponents

Note:

We reserve the right to make technical changes or modify the contents of this document without prior notice. The information, recommendations, description and safety notations in this document are based on our experience and judgment. This information should not be considered all inclusive or covering all contingencies. ABB does not accept any responsibility whatsoever for potential errors or possible lack of information in this document. If further information is required, ABB Inc. should be consulted.

We reserve all rights in this document and in the subject matter and illustrations contained therein. Any reproduction in whole or in parts is forbidden without prior written consent from ABB Inc.

With regard to purchase orders, the agreed particulars shall prevail. In no event will ABB Inc. be responsible to the user in contract, in tort (including negligence), strict liability or otherwise for any special, indirect, incidental, or consequential damage or loss whatsoever including but not limited to use of equipment, plant or power system, cost of capital, profits or revenues, cost of replacement power, additional expenses in the use of existing power facilities, or claims against the user by its customers resulting from the use of the information, recommendations, description and safety notations contained herein.

Copyright © 2011 ABB.
All rights reserved.