

Oil Preservation System, Dehydrating Breather

PTAP-ADB934

IZUA 4674-210

Installation Guide

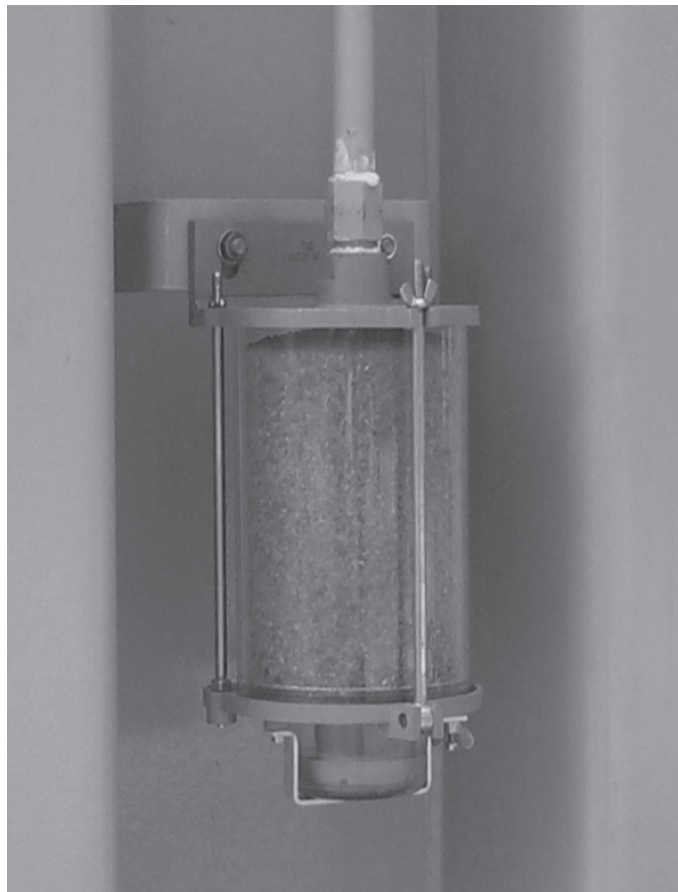

ABB

Unless otherwise specified dimensions given in this document are in millimeters.

Introduction

Dehydrating Breathers are used to prevent the normal moisture in the air from coming in contact with the oil in electrical equipment as the load or temperature changes. This reduces the degeneration of the oil and helps maintain its insulation capability. When used with a conservator system with a rubber air cell it reduces moisture accumulation in the cell.

Dehydrating Breathers come in seven sizes for application on electrical equipments with oil volumes from 235 gallons to 9,600 gallons. They can be applied in parallel to meet larger requirements.

The Dehydrating Breathers are filled with Silicagel which can absorb 20% of its own weight in moisture. The breathers are also provided with an oil trap preventing continuous contact between the moist air and the Silicagel, allowing for longer life of the Silicagel and lower maintenance.

When dry, the Silicagel has a blue color and when it has become saturated with moisture the color changes to a pale pink. This indicates it is time to replace the Silicagel with new or regenerated Silicagel. All breathers are sized to allow changing of the Silicagel approximately once a year based on normal humidity and average load cycling.

MODEL	OIL VOLUME	WEIGHT (LBS)		DIM. A mm
		BREATHER	SILICAGEL	
4101-A	300 gal	1.3	.55	140
4101-B	600 gal	1.5	1.10	205
4101-C	1200 gal	2.0	2.20	325

Dehydrating Breather Model 4101

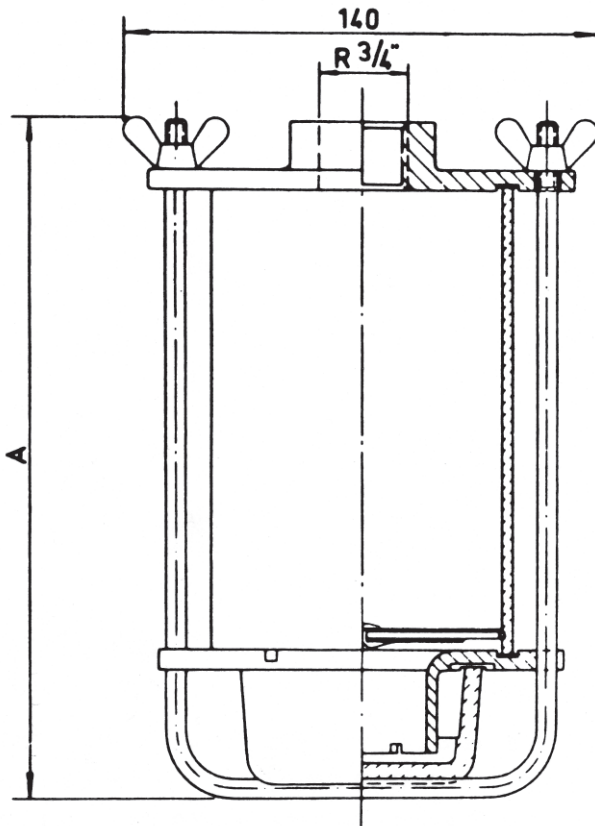

Installation procedure.

Mounting:

1. The breather is mounted by screwing into a breather pipe from the conservator system or other part of the electrical equipment.

Installation:

1. Loosen the wing nuts to enable the plexiglass container to be removed to the side.
2. Fill the plexiglass container with the correct amount of Silicagel.
3. Remove the oil trap and fill with new transformer oil to the level indicated on the trap. New oil should be used each time the Silicagel is replaced.
4. Replace oil trap and plexiglass container.
5. Tighten wing nuts, checking that both seals are in the correct position and that a good seal is achieved.

MODEL	OIL VOLUME	WEIGHT (LBS)	
		BREATHER	SILICAGEL
4170	240 gal	.77	.40

Dehydrating Breather Model 4170 for Vertical Mounting

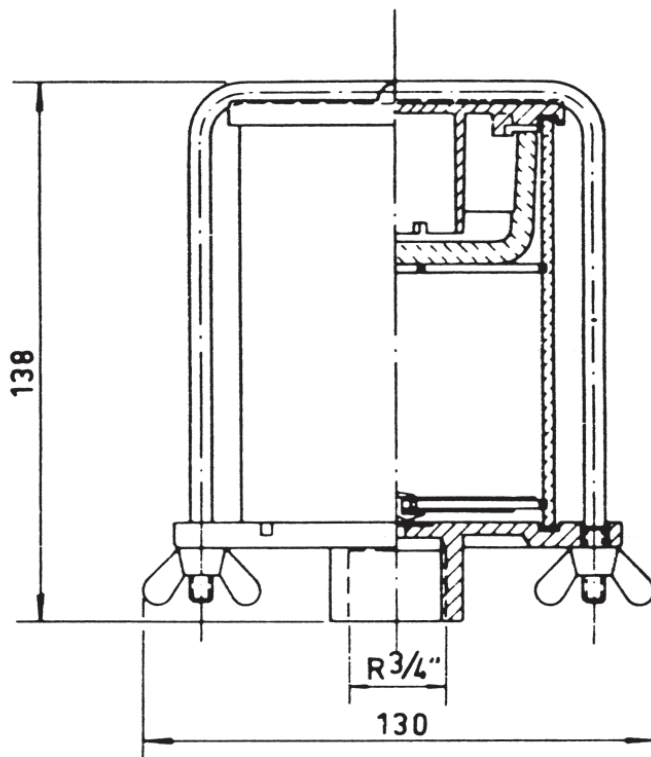

Installation procedure.

Mounting:

1. The breather is mounted by screwing into a breather pipe from the conservator system or other part of the electrical equipment.

Installation:

1. Loosen the wing nuts to enable the plexiglass container to be removed to the side.
2. Fill the plexiglass container with the correct amount of Silicagel.
3. Remove the oil trap and fill with new transformer oil to the level indicated on the trap. New oil should be used each time the Silicagel is replaced.
4. Replace oil trap and plexiglass container.
5. Tighten wing nuts, checking that both seals are in the correct position and that a good seal is achieved.

Dehydrating Breather Model 4130 and 4140

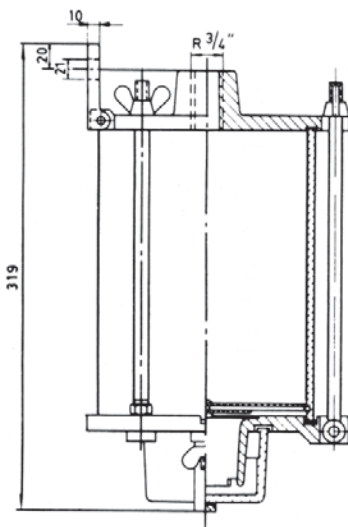

4130-2

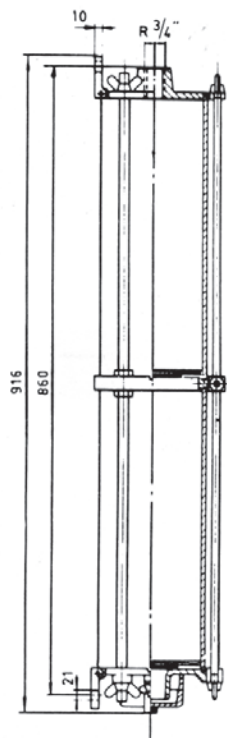

4140

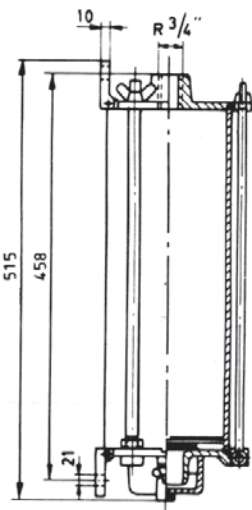

4130-4

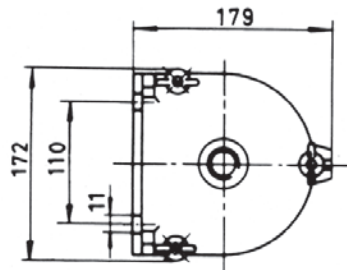

MODEL	OIL VOLUME	WEIGHT (LBS)	
		BREATHER	SILCAGEL
4130-2	2400 gal	5.94	4.4
4130-4	4800 gal	7.70	8.8
4140	9600 gal	12.54	17.6

Installation procedure.

Mounting:

1. The breather is mounted by screwing into a breather pipe from the conservator system or other part of the electrical equipment. The top cover is equipped with a mounting flange. Models 4130-4 and 4140 are also equipped with mounting flange on the bottom cover.

Installation:

1. Loosen the top wing nuts and fold forward the front support bolt. Remove the plexiglass container and fill with the correct amount of Silicagel.
2. Replace the plexiglass container, check that the seals are in the right position insuring a good seal and tighten the top wing nuts.
3. Loosen the bottom wing nuts, remove the oil cup and fill with new transformer oil to level indicated on the trap. New oil should be used each time the Silicagel is replaced.
4. Replace oil trap and plexiglass container.

**DISCLAIMER OF WARRANTIES
AND LIMITATION OF LIABILITY**

THERE ARE NO UNDERSTANDINGS, AGREEMENTS, REPRESENTATIONS OR WARRANTIES, EXPRESSED OR IMPLIED, INCLUDING WARRANTIES OF MERCHANTABILITY OR FITNESS FOR A PARTICULAR PURPOSE OTHER THAN THOSE SPECIFICALLY SET OUT BY AN EXISTING CONTRACT BETWEEN THE PARTIES. ANY SUCH CONTRACT STATES THE ENTIRE OBLIGATION OF SELLER. THE CONTENTS OF THIS DOCUMENT SHALL NOT BECOME PART OF OR MODIFY ANY PRIOR OR EXISTING AGREEMENT, COMMITMENT OR RELATIONSHIP.

THE INFORMATION, RECOMMENDATIONS, DESCRIPTION AND SAFETY NOTATIONS IN THIS DOCUMENT ARE BASED ON OUR EXPERIENCE AND JUDGEMENT. **THIS INFORMATION SHOULD NOT BE CONSIDERED TO BE ALL INCLUSIVE OR COVERING ALL CONTINGENCIES.** IF FURTHER INFORMATION IS REQUIRED, ABB INC. SHOULD BE CONSULTED.

NO WARRANTIES, EXPRESSED OR IMPLIED, INCLUDING WARRANTIES OF FITNESS FOR A PARTICULAR PURPOSE OR MERCHANTABILITY, OR WARRANTIES ARISING FROM COURSE OF DEALING OR USAGE OF TRADE, ARE MADE REGARDING THE INFORMATION, RECOMMENDATIONS, DESCRIPTIONS, AND SAFETY NOTATIONS CONTAINED HEREIN. IN NO EVENT WILL ABB INC. BE RESPONSIBLE TO THE USER IN CONTRACT, IN TORT (INCLUDING NEGLIGENCE), STRICT LIABILITY OR OTHERWISE FOR ANY SPECIAL, INDIRECT, INCIDENTAL, OR CONSEQUENTIAL DAMAGE OR LOSS WHATSOEVER INCLUDING BUT NOT LIMITED TO DAMAGE TO OR LOSS OR USE OF EQUIPMENT, PLANT OR POWER SYSTEM, COST OF CAPITAL, LOSS OF PROFITS OR REVENUES, COST OF REPLACEMENT POWER, ADDITIONAL EXPENSES IN THE USE OF EXISTING POWER FACILITIES, OR CLAIMS AGAINST THE USER BY ITS CUSTOMERS RESULTING FROM THE USE OF THE INFORMATION, RECOMMENDATIONS, DESCRIPTION, AND SAFETY NOTATIONS CONTAINED HEREIN.



ABB Inc.
1128 S. Cavalier Drive
Alamo, TN 38001, USA
Telephone: 731-696-5561
Fax: 731-696-5269
www.abb.com