



1ZSC000857-ABG en

Intelligent monitoring system, type TEC

Technical guide



Declaration of conformity

The manufacturer **ABB AB**
Components
SE-771 80 LUDVIKA
Sweden

Hereby declares that

The product Transformer Electronic Control

by design complies with the following requirements:

- EMC Directive 89/336/EEC (amended by Directive 91/263/EEC, Directive 92/31/EEC and Directive 93/68/EEC) regarding the characteristics intrinsic to emission and immunity levels *and*
- Low Voltage Directive 73/23/EEC (modified by Directive 93/68/EEC).

Date 2008-01-30

Signed by

Carl-Henrik Wigert

Title

General Manager TEC

This User's Manual has been produced to provide transformer manufacturers, and their designers and engineers, access to all the technical information required to assist them in their selection of a monitoring system. It is also intended as a TEC system information source for end-users.

The information provided in this document is intended to be general and does not cover all possible applications. Any specific application not covered should be referred directly to ABB.

ABB makes no warranty or representation and assumes no liability for the accuracy of the information in this document or for the use of such information. All information in this document is subject to change without notice.

We reserve all rights to this document and the information contained herein. Reproduction, use or disclosure to third parties without express permission is strictly forbidden.

Recommended practices

ABB recommends careful consideration of the following factors when maintaining the Transformer Electronic Control:

- Before you begin maintenance work on a unit, make sure that the personnel conducting the work have read and fully understood the *Installation and Commissioning Guide* and the *Technical Guide* provided with the unit.
- To avoid damaging the unit, never exceed the operating limits stated in delivery documents and on rating plates.
- Do not alter or modify a unit without first consulting ABB.
- Follow local and international wiring regulations at all times.
- Use only factory-authorized replacement parts and procedures.

WARNING, CAUTION, and NOTE

WARNING

A **WARNING** provides information which, if disregarded, could result in injury or death.

CAUTION

A **CAUTION** provides information which, if disregarded, could result in damage to the equipment.

NOTE: A **NOTE** provides additional information to assist in carrying out the work described.

Trademarks

Internet Explorer® and Excel® are registered trademarks of Microsoft Corporation in the United States and other countries.

HYDRAN® is a registered trademark of General Electric Company in the United States and other countries.

Table of contents

1. About this manual	7
1.1 General	7
1.2 Terminology	7
1.3 Related documentation	7
2. Introduction	8
3. Hardware	9
3.1 TEC Basic	9
3.1.1 Cabinet	9
3.1.1.1 General information	11
3.1.1.4 Front panel	12
3.1.1.5 Heater	13
3.1.1.6 Lights	13
3.1.1.7 24 V power supply	13
3.1.1.8 Standard terminals	14
3.1.1.9 Cable between TEC and transformer cabinet	14
3.2 TEC Integrated	15
3.2.1 Rack	15
3.2.1.1 General information	17
3.3 General hardware	18
3.3.1 Electronic boards and terminals	18
3.3.2 Power supply	18
3.3.2.1 Power supply board TC 110 and terminals X1, X2, X3	19
3.3.3 Processor	20
3.3.3.1 Processor board TC 122 and terminal X11	20
3.3.4 Analog input 4-20 mA	21
3.3.4.1 Analog Input 4-20 mA board TC 130 and terminal X21	21
3.3.5 Temperature input Pt100	22
3.3.5.1 Temperature input board TC 140 and terminal X31	22
3.3.6 Digital input	23
3.3.6.1 Digital input board TC 150 and terminal X41	23
3.3.7 Control and output	25
3.3.7.1 Control and output board TC 160 and terminal X51	25
3.4 Accessories	27
3.4.1 Fiber-optic converter TC 190	27
3.4.1.1 Time synchronization	27
3.4.2 Motor relay TC 180	27
3.4.3 Alarm box TC 181	28
3.5 Performed tests	29
3.5.1 EMC (Electro Magnetic Compatibility) tests	29
3.5.2 Mechanical tests, vibration and seismic	30
3.5.3 Climate tests	30
3.5.4 Fiber-optic converter TC190 tests	31
3.5.4.1 EMC tests	31
3.5.4.2 Climate tests	31
3.6 Trip, alarm, and warning output from TEC	32
3.6.1 Output signals from TEC cabinet	32
3.6.2 Alarm/Warning output options	32
3.6.3 Trip output options	33
3.6.4 Connection of devices in parallel both traditionally and to TEC	34

4. Software	36
4.1 Transformer status	37
4.1.1 Transformer top and bottom oil temperature	38
4.1.2 Current measurement	38
4.1.3 Tap-changer temperature	38
4.1.4 Tap-changer position	38
4.1.5 Voltage measurement	38
4.2 Hot-spot calculation	38
4.3 Cooling control	39
4.4 Ageing	40
4.5 Overload capacity	41
4.6 Short-time overload capacity	41
4.6.1 Overload signals	41
4.6.2 Top oil trend	41
4.7 Hot-spot forecasts	42
4.8 Tap-changer contact wear	43
4.9 Hydrogen	44
4.10 Moisture content in the transformer and tap-changer oil	45
4.11 Transformer temperature balance	45
4.12 Tap-changer temperature balance	46
4.13 On-site configuration	46
4.14 Event handling	46
4.14.1 Event list	47
4.14.2 Protection	48
4.14.3 Sensor backup	48
4.14.3.1 Effect of sensor failure on functions	49
4.14.4 Message boxes	50
4.15 Cabinet conditions	50
4.16 Communication	50
4.17 Configurable inputs	51
4.18 Ordering data	51
4.18.1 Load test	51
5. Installation	52
5.1 Sensors	52
5.1.1 Air temperature	53
5.1.2 Oil temperature	54
5.1.3 Current transducer	55
5.1.4 Hydrogen gas in oil	55
5.1.5 Moisture in oil sensor	55
5.2 Cables and earthing	56
5.2.1 Pt100	56
5.2.2 Digital in	56
5.2.3 4 – 20 mA	56
5.2.4 RS 485 and data communication	56
5.2.5 CAN communication	56
5.2.6 Cable entry and Roxtec	57
5.3 Time synchronization	57
6. TEC Server	58

1. About this manual

1.1 General

This manual describes the hardware and software functions of the Intelligent Monitoring System, type TEC. The TEC is an electronic control, monitoring, and diagnostic device.

The information in this manual is intended for operators. The reader of this manual should understand the hardware and software functionality of the TEC system.

1.2 Terminology

The following is a list of terms associated with the TEC system with which you should be familiar. The list contains terms and abbreviations that are unique to ABB or that have a usage or definition that is different from standard industry usage.

Term	Description
TEC	Intelligent Monitoring System.
TEC Server	The PC hardware containing the TEC Server web.
TEC Server Web	The web system on the TEC Server.
HEX	File extension for program files on the TEC system. The abbreviation stands for hexadecimal file.
OPC	OLE for Process Control.

1.3 Related documentation

The table below lists all documentation related to the TEC system.

Title	Document ID	Description
Installation and Commissioning Guide	1ZSC000857-ABH	Describes installation and configuration of the TEC system.
Hard Facts	1ZSE 954003-003	Sales document that describes the basics and fundamentals of the TEC system.
User's Manual	1ZSC000857-ABK	This document describes the different functionalities of the TEC and how operators work via the cabinet display or the web interface.
Maintenance Guide	1ZSC000857-ABJ	This document contains descriptions about the TEC embedded web interface and how to load HEX files into the TEC. This document is intended for operators.
TEC Server – User's Manual	1ZSC000857-ABL	This manual describes the user interfaces in the Intelligent Monitoring System TEC Server.
Additional information		www.abb.com/electricalcomponents

2. Introduction

Equipping a transformer with an electronic control device opens the door to any number of new possibilities compared with current relay techniques. Monitoring and diagnostics tools can be included and all transformer-related information can be gathered in one place for evaluation and storage. The electronic control device will not only replace functionality that is currently mostly achieved with relay techniques – it can add several new features to improve transformer performance.

ABB's Intelligent Monitoring System (TEC) is an electronic control, monitoring, and diagnostic device. The system is configured using a "fingerprint" of the transformer. The device provides a single interface to the entire transformer with current and historical status data and the potential to predict loads. A minimum number of extra sensors is needed.

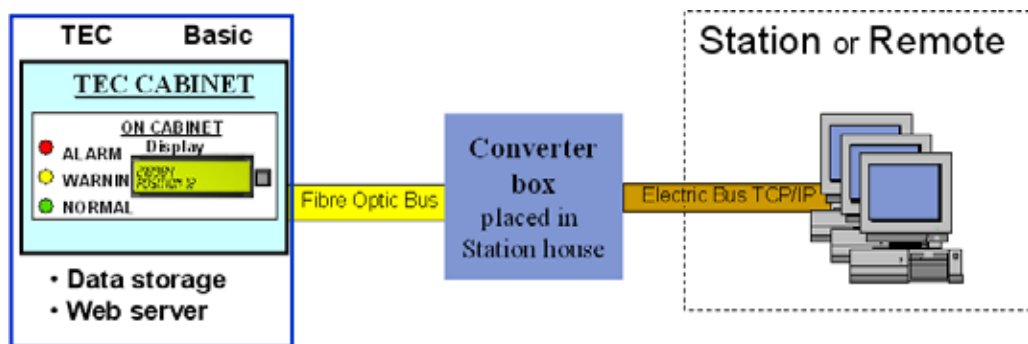

tec_0220

The inputs from the different sensors are connected to the input boards of the TEC unit. The TEC unit collects and processes the data. The unit uses detailed mathematical models of the transformer, including fingerprint data from the heat run test. The results can be transferred to the control system and/or viewed via a graphic web interface on a PC. The TEC has a built-in web server and a flash memory for data storage.

The system is configured when ordering by filling in the order data sheet and is then delivered ready-configured according to said specification.

3. Hardware

There are two versions of the TEC unit:

- TEC Basic
- TEC Integrated.

The basic model is mounted in a TEC cabinet.

The integrated model is based on the same concept as TEC Basic, but without the TEC cabinet. It is located on a rack that can be mounted inside the transformer cabinet.

3.1 TEC Basic

The TEC Basic model is mounted in a TEC cabinet with its own terminal groups.

3.1.1 Cabinet

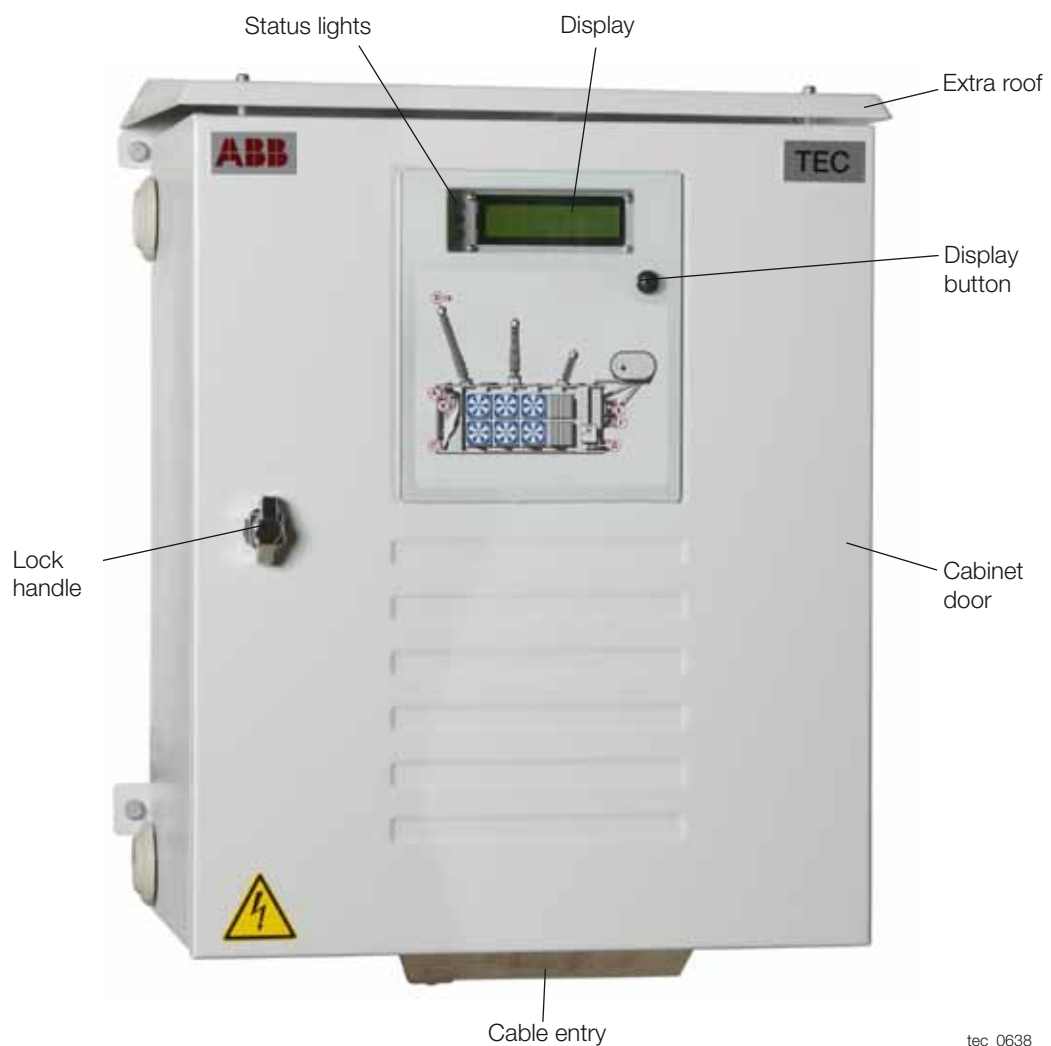

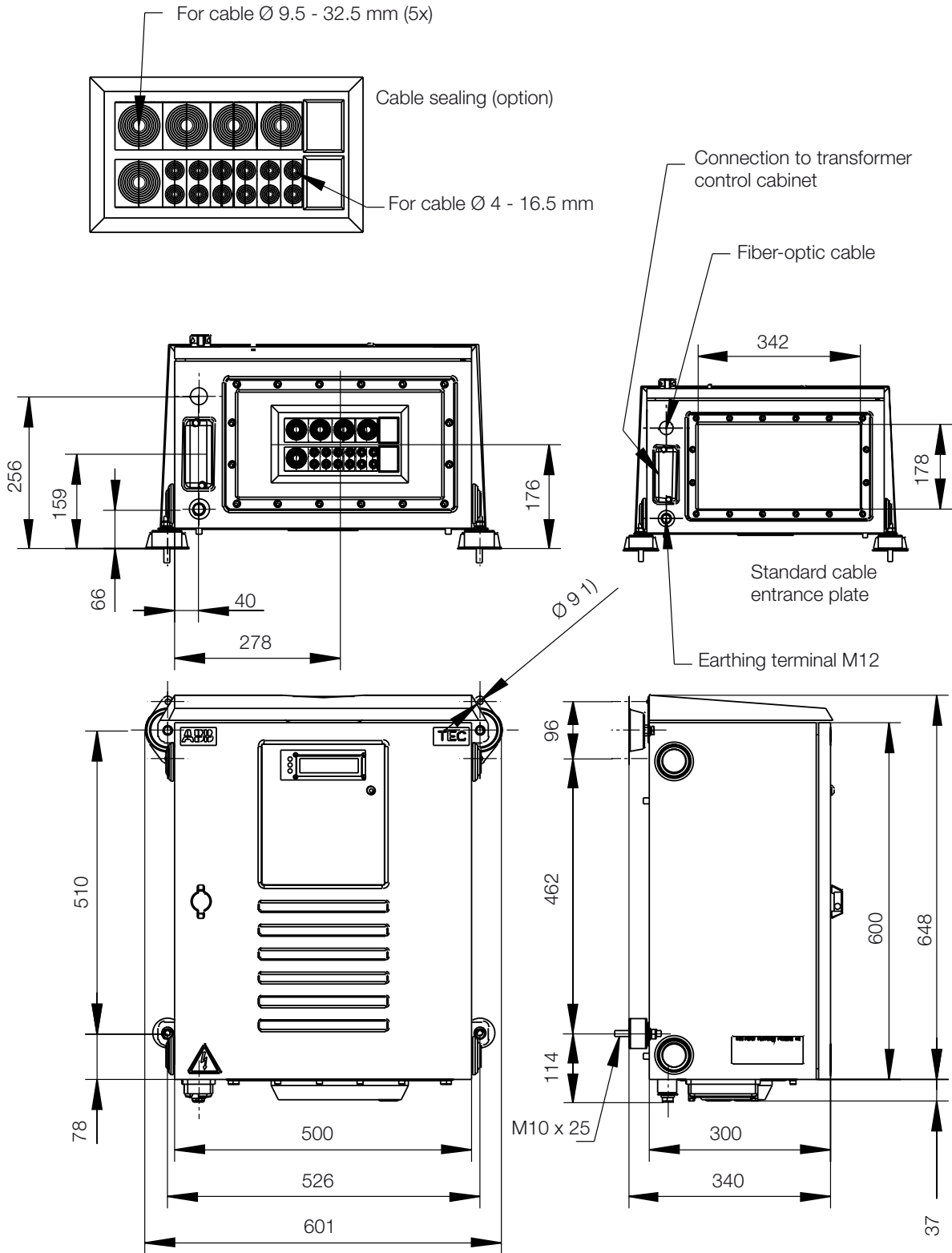

tec_0019

1) Mounting holes on the transformer.

3.1.1.1 General information

Environment

Operating temperature	-40 to +55 °C (-40 to 131 °F)
Degree of protection	IP 54, according to IEC 60529
Temperature cycling tested	-40 to +70 °C, 90 % humidity according to IEC 60068-1, IEC 60068-2, IEC 60068-3, and IEC 60068-5
Dimensions (mm)	Width 600, Height 650, Depth 340
Weight	35 kg
EMC compliance	IEC 61000-4, EN 61000-6-2 and EN 61000-4
Vibration tested	IEC 60255-21-1, IEC 60255-2, IEC 60255-3 and IEC 60068-2-6, IEC 60068-27, IEC 60068-29
Temperature cycling	IEC 60068-2
Max. cable area to terminals	2.5 mm ²
Max. cable area to temperature input Pt100	1.5 mm ²
Color	RAL 7035

Input parameters

The cabinet for the TEC Basic model has the following input parameters:

- 8 insulated analog 4-20 mA inputs via terminals (for current transformers, sensors, etc.)
- 4 insulated Pt100 direct inputs (for temperature sensors)
- 12 insulated digital input via terminals (for fan motor status, alarm/trip signals, etc.)
- 1 input for the tap-changer position, resistor bridge ($R_{tot} \geq 80 \Omega$ or $R_{step} \geq 10 \Omega$).

The number of input signals can be increased.

Output parameters

The cabinet for the TEC Basic model has the following output parameters:

- 3 outputs for alarm, warning, and trip signals
- Permitted load breaking capacity on output terminals are AC 250 V 8 A, DC 250 V 0.1 A L/R=40 ms, DC 30 V 5 A.

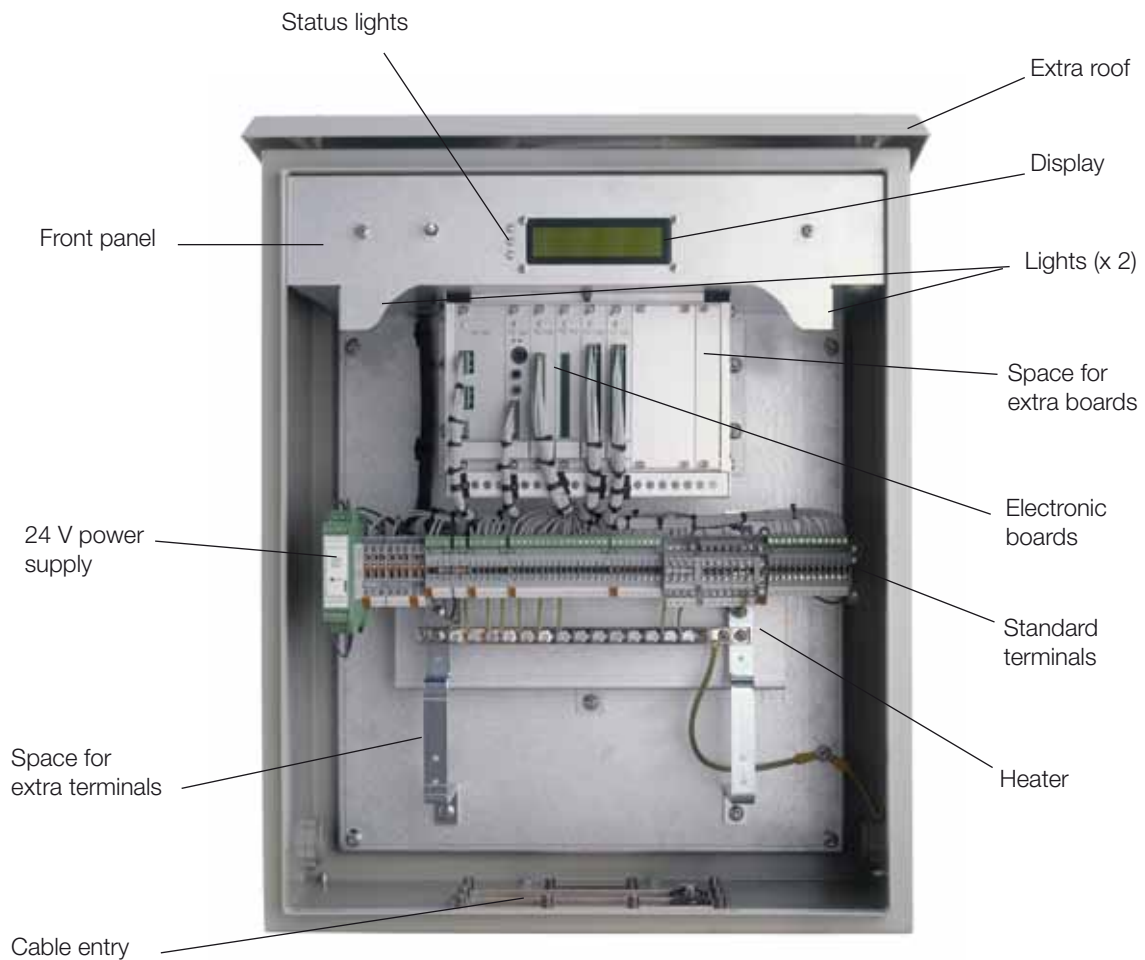

tec_0045

3.1.1.4 Front panel

Status light (inside the cabinet)

- **Red** light indicates Alarm or Trip condition
- **Yellow** light indicates Warning condition
- **Green** light indicates Normal conditions

Display (on cabinet)

The display shows different information values when the button on the front of the cabinet is pressed.

The information on the display is easily configured from a PC to show other available information. It is also possible to present information in the display about the reason behind a Warning or an Alarm. The temperatures are displayed in both degrees Celsius and degrees Fahrenheit.

The TC 170 display board is connected to the processor board on delivery.

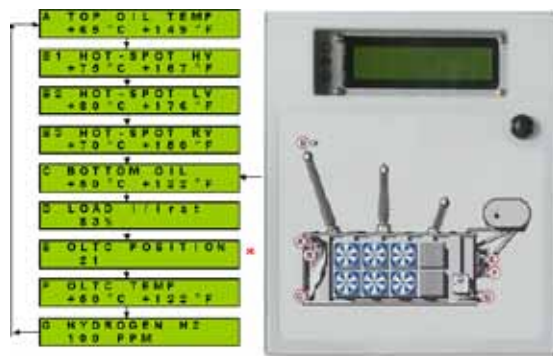

* Position only shown with numbers 1..n

tec_0634



tec_0057

Information that can be shown on the display:

A TOP OIL
 B1 HOT-SPOT HV
 B2 HOT-SPOT LV
 B3 HOT-SPOT TV
 C BOTTOM OIL
 D LOAD I/I_{rated}
 E OLTC POSITION
 F OLTC TEMP1
 F OLTC TEMP2
 F OLTC TEMP3
 F OLTC TEMP4
 G HYDROGEN H2

TFO Moisture

OLTC Moisture

Voltage

E1: Extra 1
 E2: Extra 2
 E3: Extra 3
 E4: Extra 4
 E5: Extra 5
 E6: Extra 6
 E7: Extra 7
 E8: Extra 8
 E9: Extra 9
 E10: Extra 10

IP Address

Information in *italics* relates to optional sensors and is displayed when available.

3.1.1.5 Heater

The cabinet heater is connected to the TEC's AC supply. It is designed for an AC supply of 100-240 V. Depending on the temperature in the cabinet, the heater can provide 100-135 W. (At -30°C the heating power is 135 W.)

3.1.1.6 Lights

The illumination in the cabinet consists of two lights below the front panel. The lights are standard automotive light bulbs of type Ba15s 18 x 35, 24 V, 10 W.

3.1.1.7 24 V power supply

The 24 V power supply is only intended to supply the lights.

3.1.1.8 Standard terminals

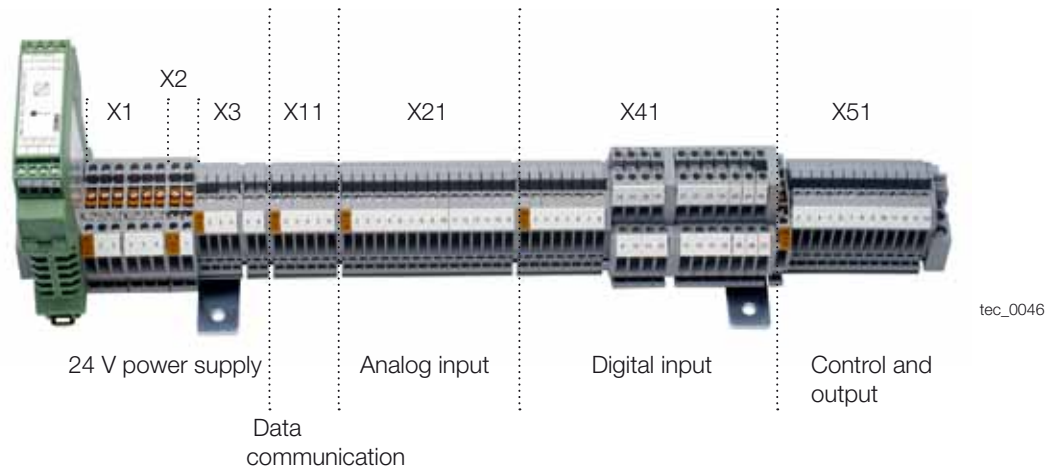

3.1.1.9 Cable between TEC and transformer cabinet

The cable can be used for an easy connection between the transformer cabinet and the TEC unit. The cable consists of:

- One shielded twisted pair cable marked A. The cable is intended for RS 485 communication to the motor and alarm boxes. Note that only two of the wires are connected.
- Two shielded cables with two twisted pairs each.
- 24 single conductors.



3.2 TEC Integrated

The TEC Integrated model is located on a rack and is based on the same concept as TEC Basic, but without the TEC cabinet and the heater.

3.2.1 Rack

The advantage of the Integrated version is that it can be mounted inside the transformer cabinet. The Integrated model has a display with the same functionality as the Basic model display. For more information about the display, see section 3.1.1.4.

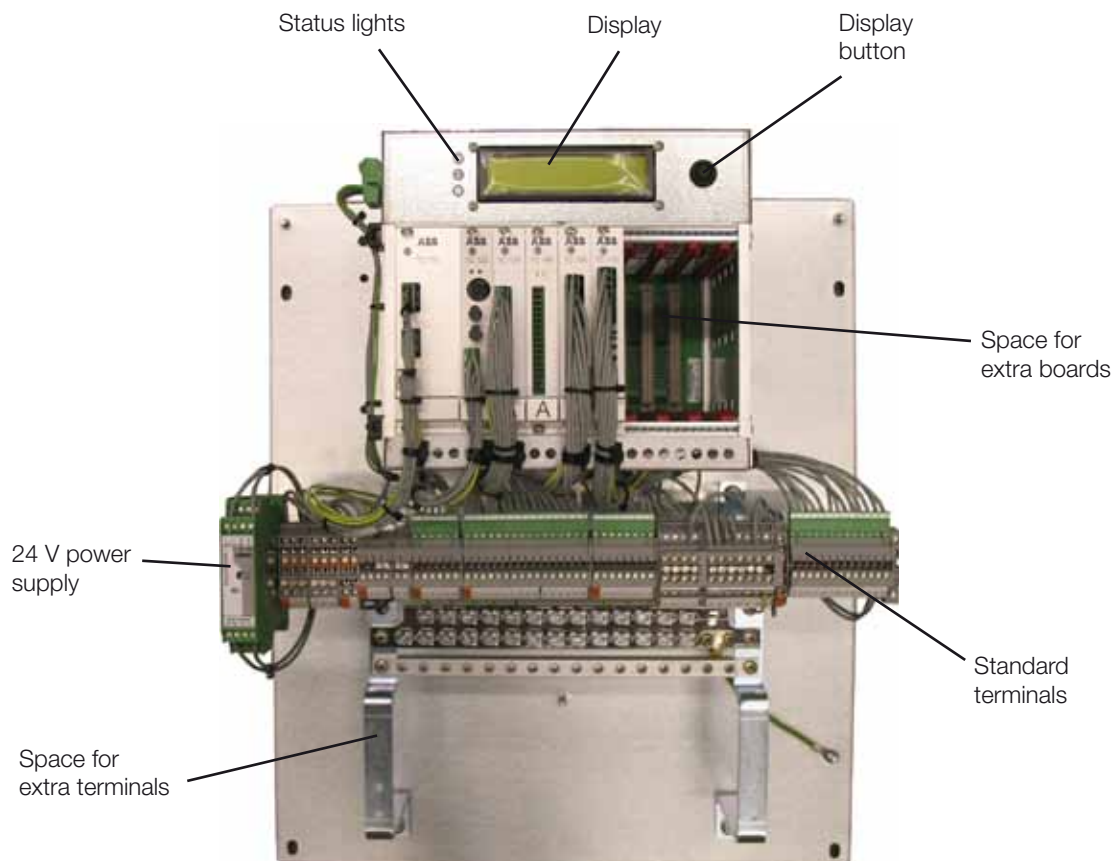

tec_0249

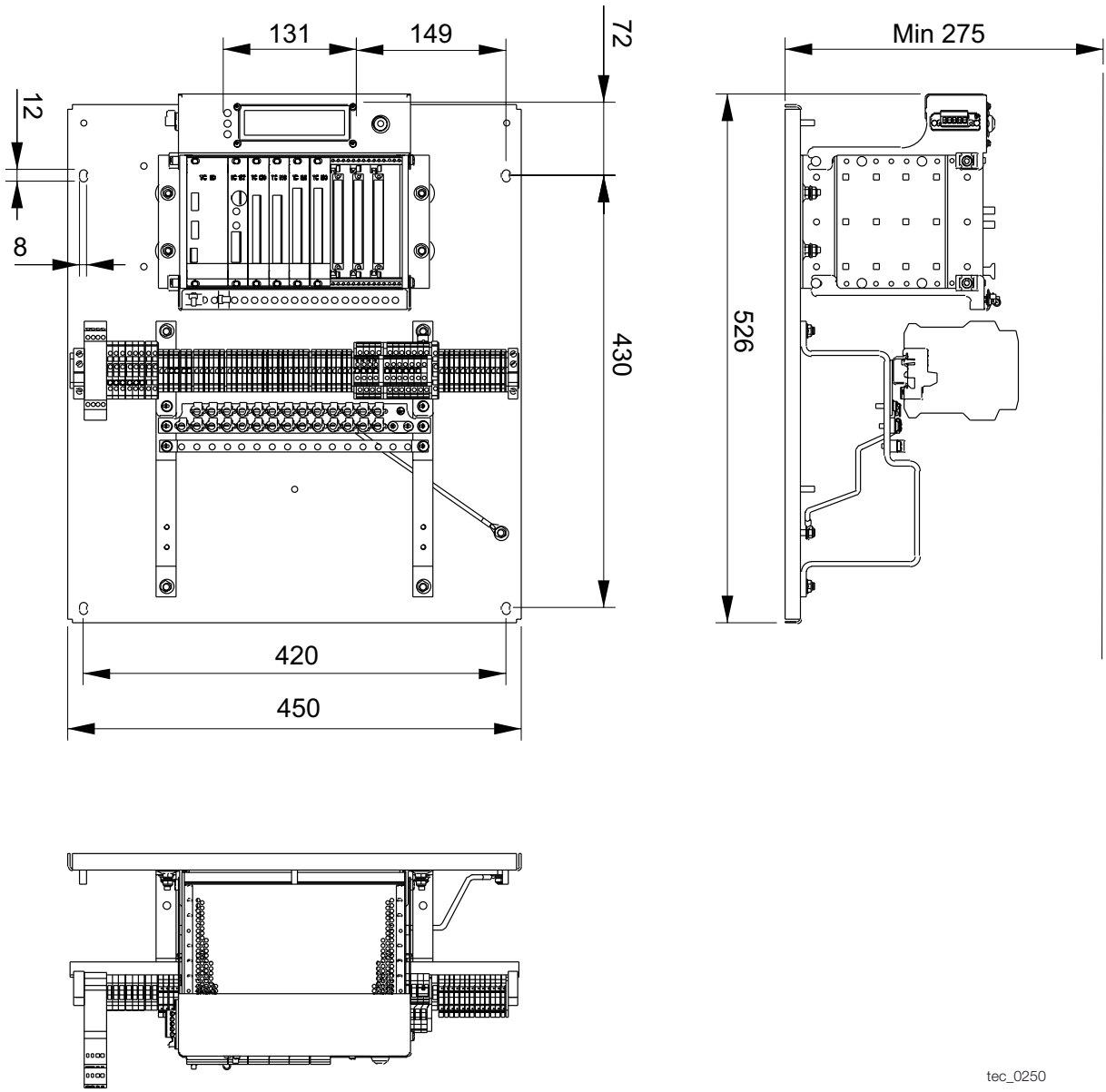

tec_0250

3.2.1.1 General information

Environment

Operating temperature	-40°C to +70°C (32 to 150°F)
Degree of protection	IP 20, according to IEC 60529
Dimensions (mm)	Width 450, Height 526, Depth 275
Weight	5 kg
EMC compliance	IEC 61000-4, EN 61000-6-2 and EN 61000-4
Vibration tested	IEC 60255-21-1, IEC 60255-2, IEC 60255-3 and IEC 60068-2-6, IEC 60068-27, IEC 60068-29
Max. cable area to connection plug	1.5 mm ²

Input parameters

The rack of the TEC Integrated model has the following input parameters:

- 8 insulated analog 4-20 mA inputs (for current transformers, sensors, etc.)
- 4 insulated Pt100 direct inputs (for temperature sensors)
- 12 insulated digital inputs (for fan motor status, alarm/trip signals, etc.)
- Input for the tap-changer position, resistor bridge ($R_{tot} \geq 80 \Omega$ or $R_{step} \geq 10 \Omega$).

The number of input signals can be increased.

Output parameters

The rack of the TEC Integrated model has the following output parameters:

- 3 outputs for alarm, warning, and trip signals
- Permitted load breaking capacity on output terminals AC 250 V 8 A, DC 250 V 0.1 A L/R=40 ms, DC 30 V 5 A

Enclosure requirements

Degree of protection	IP 54 or higher
Damp heat	non-condensing

3.3 General hardware

3.3.1 Electronic boards and terminals

The electronic boards are mounted on a back-plane providing internal communication and power supply between the boards.

The boards are placed in the following order from left to right:

- Power supply board, TC 110
- Processor board, TC 122
- Analog input 4 – 20 mA board, TC 130
- Temperature input Pt100 board, TC 140
- Digital input board, TC 150
- Control and output board, TC 160

To the right of these standard boards there are three extra slots for max. two analog input 4-20 mA boards and/or temperature input Pt100 boards and/or digital input boards.

The standard setup also comprises the following board:

- Display board, TC 170 (at the front of the TEC cabinet)

Extras:

- Motor relay board, TC 180 (in the transformer control cabinet)
- Alarm box, TC 181 (in the transformer control cabinet or in the TEC unit)

3.3.2 Power supply

WARNING

Dangerous voltage!

The TEC unit can work with either AC or DC power (Universal 110-230 V AC, 50/60 Hz and 85-265 V DC). It is recommended to connect both AC as the main supply and DC from the station battery as back-up. It is also possible to connect two different AC supplies. The power supply board will automatically switch between the two supplies without interruption if one fails.

The power consumption of the electronic boards is <20 W plus the consumption of sensors. The cabinet heater element is connected to the input AC supply and can have a peak current up to 8 A. A fuse of at least 10 A is recommended.

Each terminal can be disconnected by moving the orange terminal disconnection bar downwards.

3.3.2.1 Power supply board TC 110 and terminals X1, X2, X3

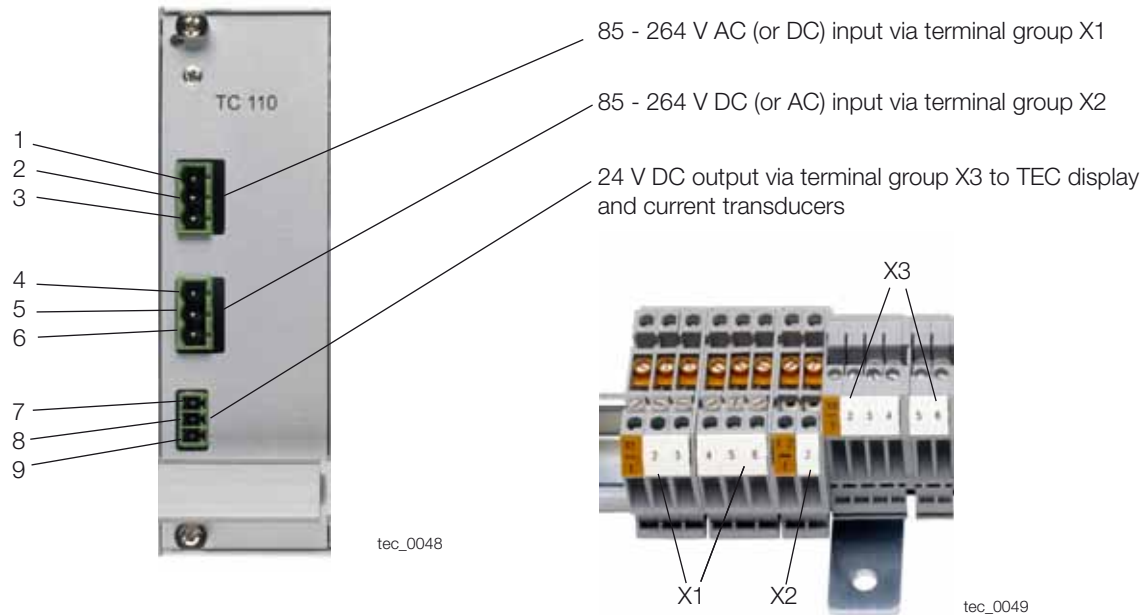

Terminal group X1

- 1 Input 85 - 264 V AC 50/60 Hz line voltage.
- 2,3 Output AC line voltage. Connected to X1:1 and is **always** live, even if the terminal disconnection bar is moved to the disconnected position. This terminal can be used to supply special sensors with power.
- 4 Input AC neutral.
- 5, 6 Output AC neutral.

Terminal group X2

- 1 Input 85-264 V DC positive.
- 2 Input 85-264 V DC negative.

Terminal group X3

- 1 Output 24 V DC positive from the power supply board. The display (1.6 W) is internally wired to this supply. Up to 3 current transducers can also be connected here. Maximum total load on this supply is 5 W.
- 2 Output 24 V DC negative from the power supply board. Up to 3 current transducers can also be connected here.
- 3 Input 24 V DC positive from a separate 24 V supply unit in the TEC cabinet (connected on delivery). This power feeds the cabinet light.
- 4 Output 24 V DC positive from X3:3. This terminal is used to power 4 - 20 mA sensors (except for current transformers, CTs).
- 5 Input 24 V DC negative.
- 6 Output 24 V DC negative from X3:5.

3.3.3 Processor

3.3.3.1 Processor board TC 122 and terminal X11

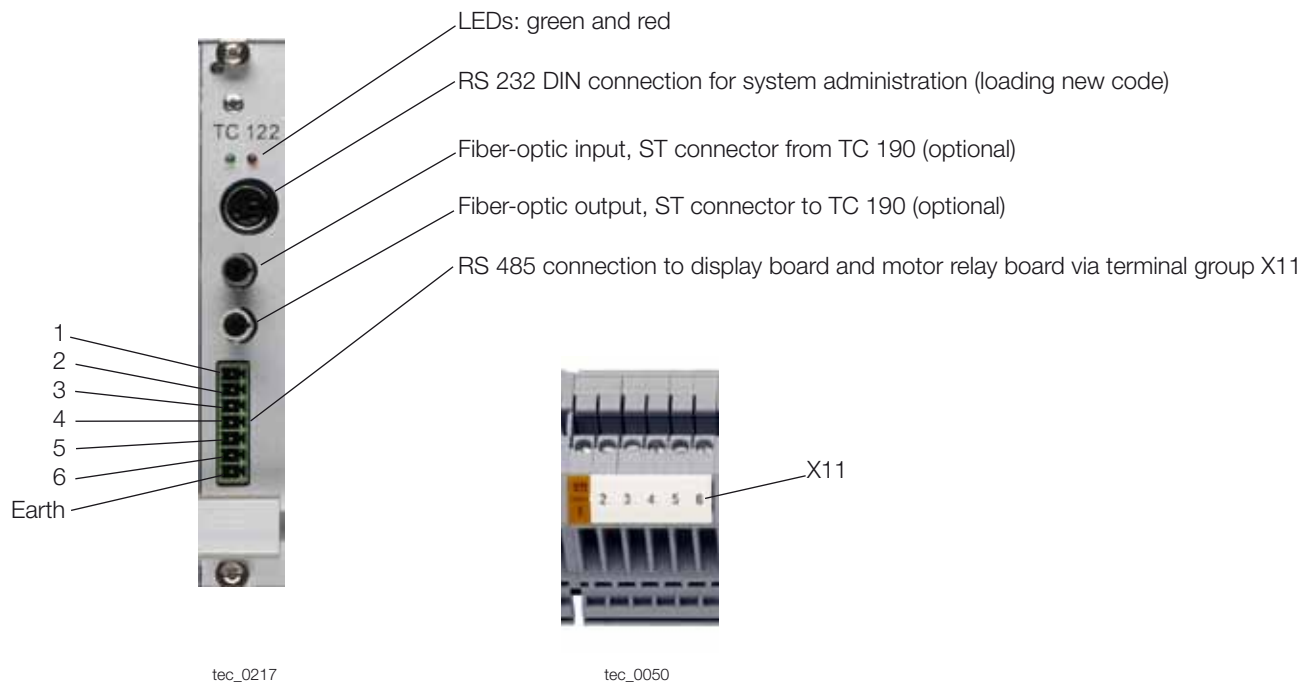

Terminal group X11

- | | |
|---|---|
| 1 | CAN bus, High |
| 2 | CAN bus, Low |
| 3 | CAN bus, CAN signal ground |
| 4 | CAN bus, protective earth |
| 5 | RS485 connection A to motor relay board |
| 6 | RS485 connection B to motor relay board |

3.3.4 Analog input 4-20 mA

3.3.4.1 Analog Input 4-20 mA board TC 130 and terminal X21

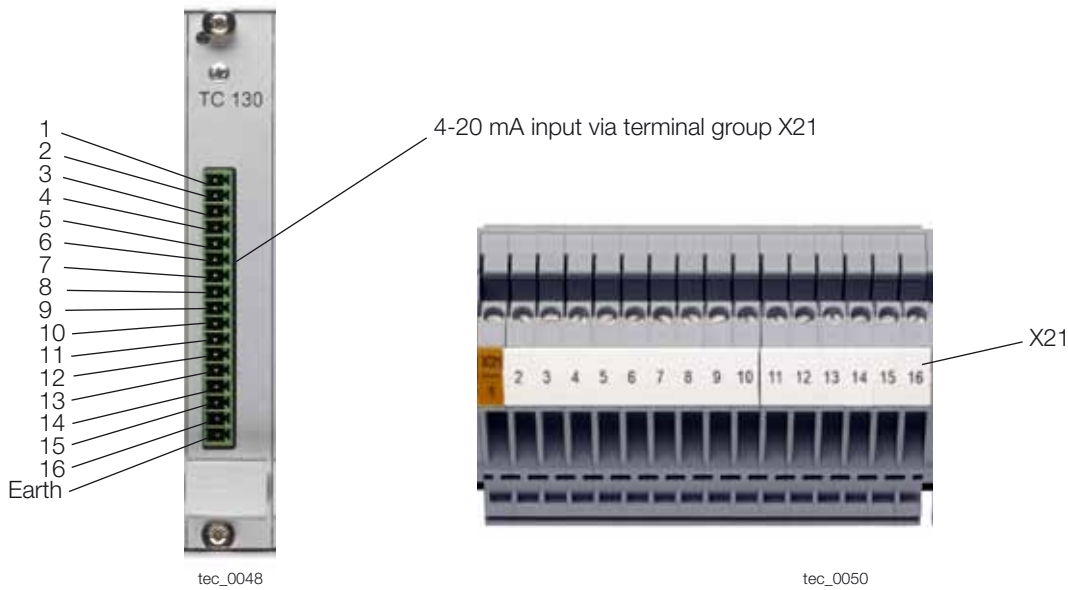

The sensors are calibrated and assigned to their terminals on delivery, see section 4.17 *Ordering data*.

If a new calibration is needed, see the *User's Manual*.

The three current transducers can take the 24 V DC supply from X3:1 and X3:2. The power supply for other sensors that require 24 V DC shall be provided by the transformer manufacturer.

Terminal group X21

This is the default configuration for 4–20 mA sensors. For other configurations, see the *ordering data sheet*.

1	2	Current High Voltage side of transformer
3	4	Current Low Voltage side of transformer
5	6	Current Tertiary Voltage side of transformer
7	8	Tap-changer temperature taken from moisture sensor (can have other power supply than 24 V DC)
9	10	Tap-changer moisture in oil sensor (can have other power supply than 24 V DC)
11	12	Transformer temperature taken from moisture sensor (can have other power supply than 24 V DC)
13	14	Hydrogen (can have other power supply than 24 V DC)
15	16	Transformer moisture in oil sensor (can have other power supply than 24 V DC)

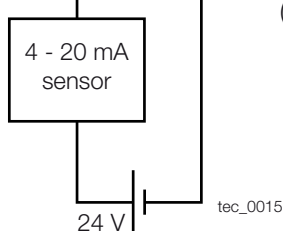

Additional TC 130 boards use the same principle.

Current transducer

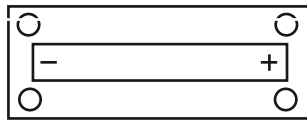

The current transducer is connected to the TEC unit as follows:

1. Connect +24 V from X3:1 to “plus” side of sensor.
2. Connect “minus” side of sensor to TEC terminal (low terminal number 1, 3 and 5).
3. Connect 0 V from X3:2 to TEC terminal (high terminal number 2, 4 and 6).

3.3.5 Temperature input Pt100

In order to improve measuring accuracy, Pt100 temperature sensors are connected directly to the front of the board, not via the terminals at the bottom of the cabinet. This connection is designated Terminal group X31. If one or more extra boards are needed, they must be placed after the standard boards and the terminal groups will be designated X32, X33, etc.

Pt100 sensors are calibrated on delivery and need no recalibration.

3.3.5.1 Temperature input board TC 140 and terminal X31

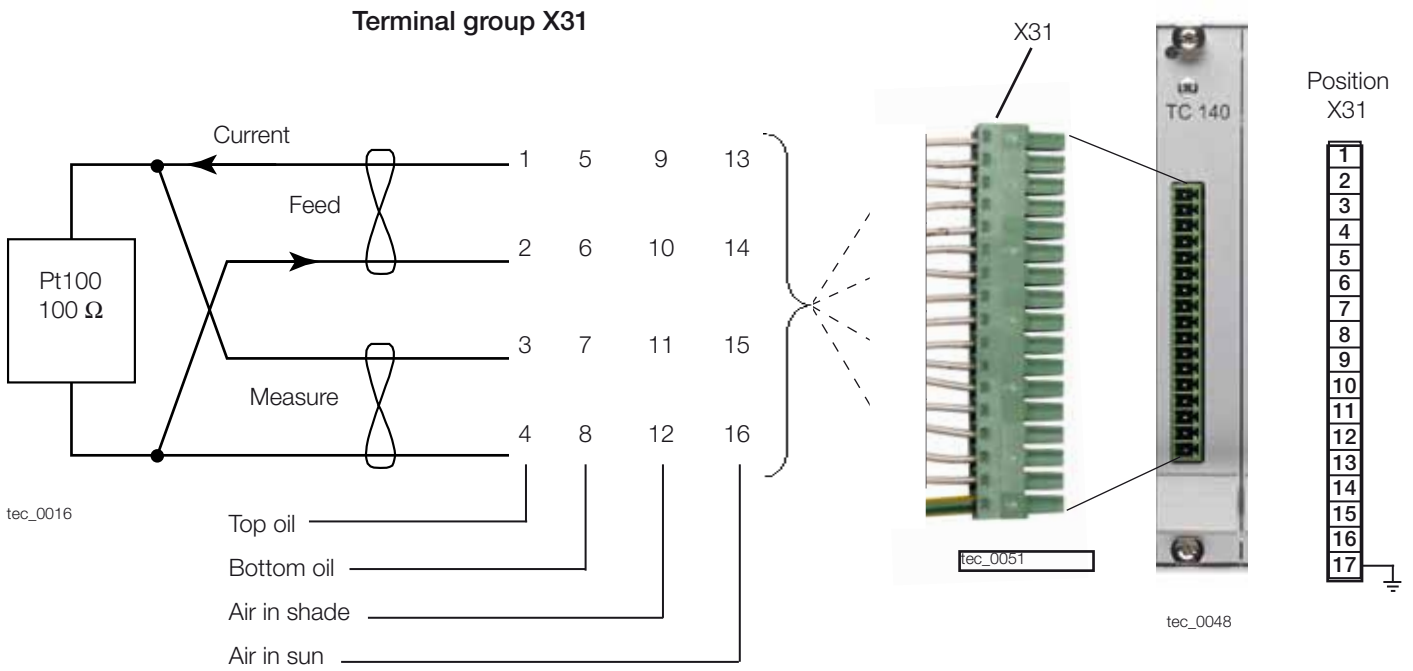

Additional TC 140 boards use the same principle.

3.3.6 Digital input

3.3.6.1 Digital input board TC 150 and terminal X41

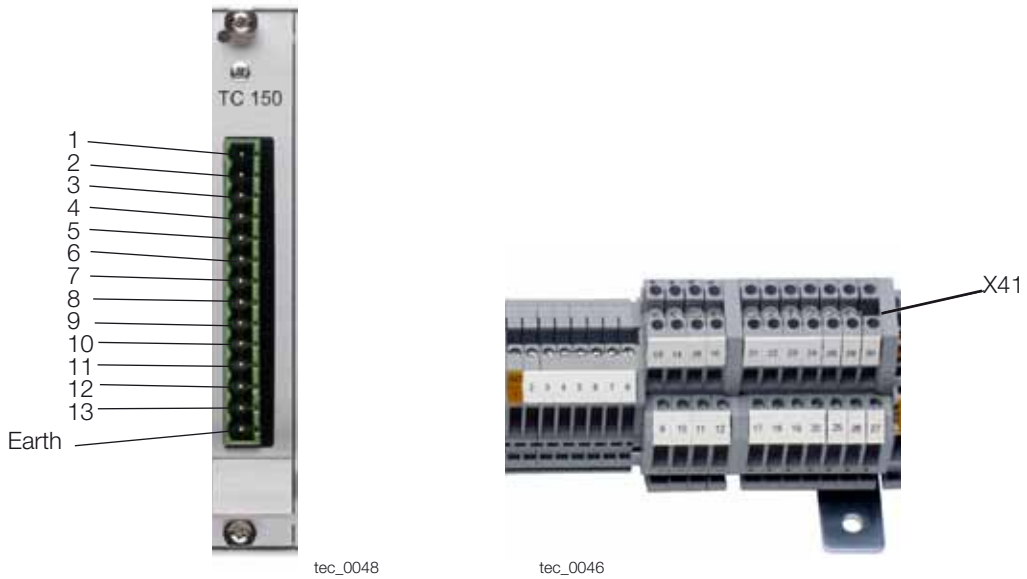

The digital input board interprets relay signals of two different types:

- Function confirmation that a device is running properly, where an open relay contact means that the device is not running and a closed contact indicates that it is running.
Example: Oil flow indicator in a cooler circuit.
- In case of TEC cooling group control, the feedback from each cooler group needs to be connected to the TEC unit. The first input must be connected to input X41:1 and then the following inputs.
- Warning, alarm, and trip devices, where an open relay contact indicates normal function and a closed contact generates a warning, alarm, or trip signal.
Example: Sudden pressure relay.

For each contact connected to the digital input board, the type is defined by the data entered on the ordering data sheet.

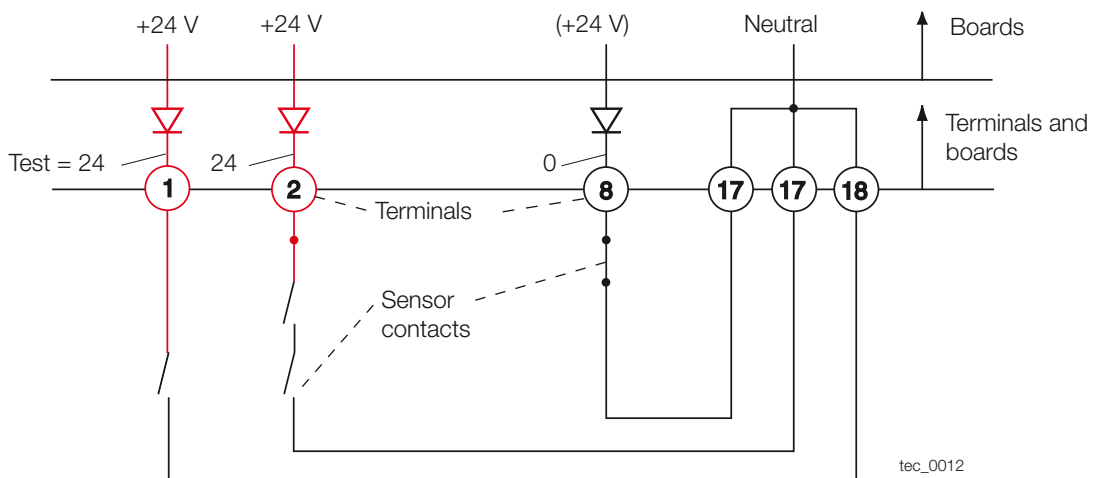

Terminals 1-8 are available for warning and alarm contacts, e.g. the oil level detector and Bucholz relay (warning levels). Any of these eight terminals can also be used for “function confirmation” type contacts. In such cases, the related contacts from each cooler group must be connected in series to the same terminal, e.g. the auxiliary contact on a fan motor contactor and the oil flow indicator of the same cooler group. When the TEC controls the coolers, each cooler group shall provide a function confirmation signal to the digital input board.

The digital input board feeds +24 V DC to the terminal and also measures the voltage at the terminal. As long as the sensor contact is open, the voltage is maintained and the status of warning/alarm signals is OK. The status of function signals is “not running”, which is also OK as long as the cooler group is not switched on. When a sensor contact is closed, the voltage supply from the board cannot maintain 24 V, the measured voltage drops to zero and an error signal is generated for warning/alarm inputs.

Function inputs change status to “running”. The warning/alarm signal is generated (or the function changes to “running”) when the measured voltage is below 8 V.

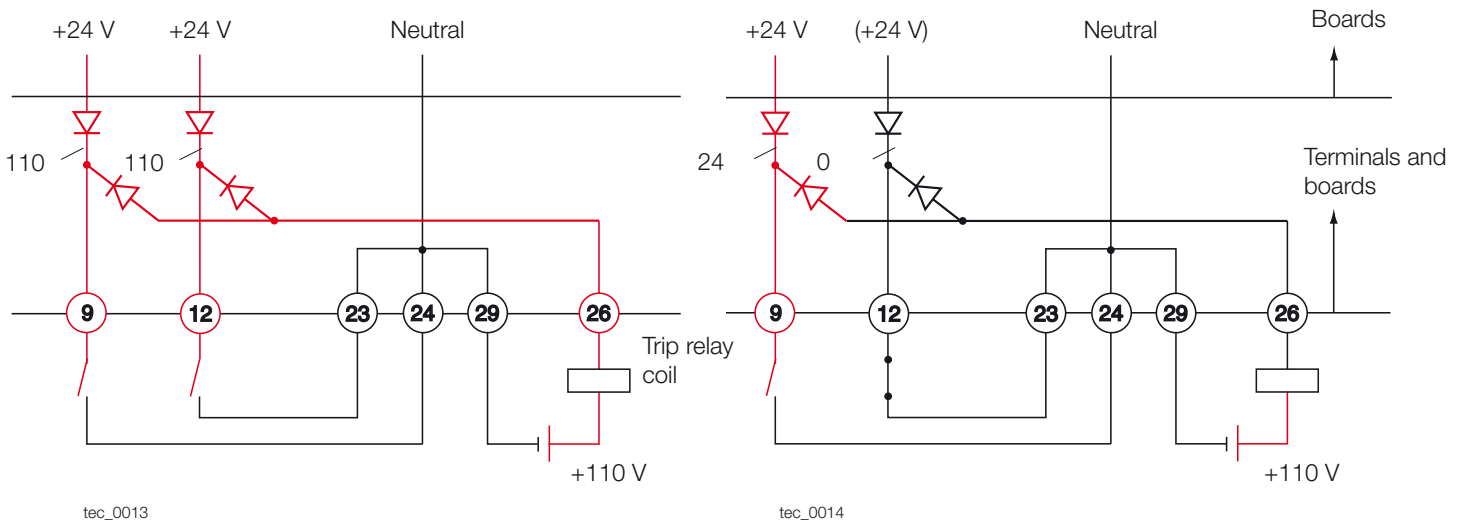

Terminals 9-12 are available for sensor contacts normally used to trip the transformer, e.g. sudden pressure relay and Bucholz trip contacts. This example shows how two sensor contacts, a 110 V battery, and the trip relay coil are connected. As long as all sensor contacts are open, the measured voltage is 110 V and the status is OK. If one contact closes, the 110 V circuit is closed, the current through the trip relay coil trips the transformer, and the measured voltage at the terminal drops to zero. The battery voltage also disappears from the other terminals, but then the 24 V supply from the board maintains the measured voltage above 8 V.

Any of the twelve terminals can activate a warning, an alarm, or a trip signal from the TEC via the output auxiliary relay contacts of the control and output board (see section 3.3.7 Control and output).

If more than 8 warning/alarm/function or 4 trip sensors are used, one or more extra boards are needed. The terminal groups are placed at the lower terminal row and designated X42, X43, etc.

Terminal group X41

Each sensor is connected to one of the terminals 1-12 and one of the neutral terminals 17-24.

- 1 - 8 Input warning/alarm and function sensor contacts.
- 9 - 12 Input trip sensor contacts.
- 13 - 16 Shall not be used.
- 17 - 24 Input neutral. Each terminal number represents two terminals, one on the upper side and one on the lower side.
- 25 Shall not be used.
- 26 Input positive DC from battery and trip relay coil according to diagram above. Voltages above +220 V DC and negative voltages are not permitted.
- 27 - 28 Shall not be used.
- 29 Input neutral from battery and trip relay coil.
- 30 Shall not be used.

See section 3.6 for trip and alarm/warning functionality.

3.3.7 Control and output

3.3.7.1 Control and output board TC 160 and terminal X51

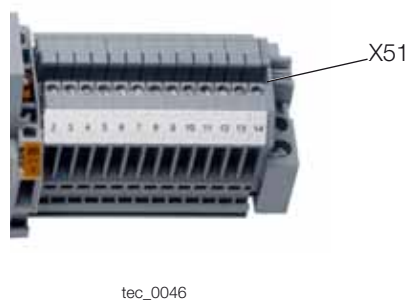
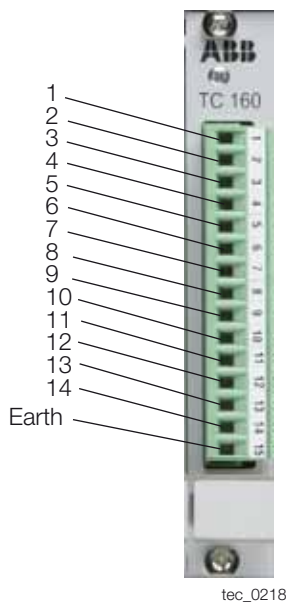

This board is used to create relay signals.

WARNING

Dangerous voltage!

Terminal group X51

- | | | |
|--------|---|--|
| 1 | Output disconnectable terminal in series with terminal 14 (Disconnected in downwards position.) | |
| 2 - 3 | Input voltage measurements. Nominal voltage 85–140 V AC. Neutral on 3. | |
| 4 - 6 | Input tap-changer position transmitter,
4 = max. position, 5 = moving contact,
6 = min. position. $R_{tot} \geq 80 \Omega$ or
$R_{step} \geq 10 \Omega$. 0 Ω in pos 1. | |
| 7 - 9 | Configurable output dry contact. | |
| 10, 12 | Output dry contact for warning. | |
| 11, 12 | Output dry contact for alarm. | |
| 13, 14 | Output dry contact for trip.
This output also has a contact that can be disconnected at terminal 1.
These contacts are wired to the digital board to create a trip output on X41:26 and X41:29. | |

Permitted load

Permitted load (breaking capacity) on output terminals:

AC 250 V 8 A

DC 250 V 0.1 A L/R = 40 ms

DC 30 V 5 A

isc_0017

3.4 Accessories

3.4.1 Fiber-optic converter TC 190

For remote data communication, including within the station building, a fiber-optic connection should be used.

The fiber-optic cable should be connected to the TC 190 converter. The TC 190 converter should be placed indoors and requires a separate 24 V DC power supply.

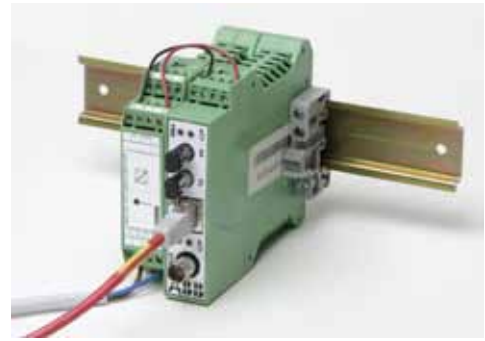

tec_0215

3.4.1.1 Time synchronization

The input signal for the time synchronization should be 5 V with 50 Ω output impedance. The connection is a BNC contact and it is recommended to use a shielded coaxial cable. The pulse should have positive flank for indication.

3.4.2 Motor relay TC 180

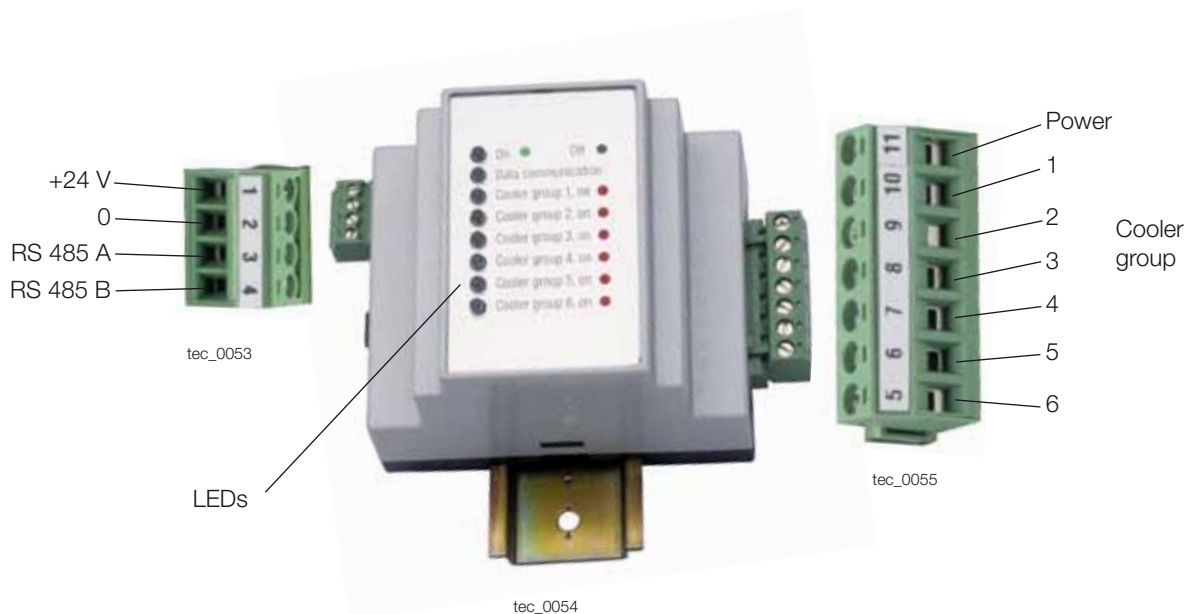

The TC 180 motor relay board is placed in the transformer control cabinet.

All fans and pumps in a single cooler group must be connected so that they are started by one relay output. Up to six separate groups can be controlled. The shielded cable A in the cable between the TEC and the transformer cabinet is intended for the RS 485 communication. If the RS 485 connection to the TEC is lost, all relays will close automatically one by one at 10-second intervals. A closed relay is represented by a lit LED. It is recommended that the motor relay board be supplied with 24 V DC from the transformer cabinet to ensure that all motors start even if the connection to TEC fails totally. If the power supply to the TEC unit is disconnected the motor relay board starts all cooler groups. To avoid this when the transformer is out of service, first disconnect the 24 V supply from the motor board. The TEC power supply should also be connected before the 24 V power supply to the motor board to avoid starting the coolers.

A traditional top oil thermometer is also recommended to be used as a back-up together with this TEC model. It should be set to start all cooler groups 5°C above the highest start temperature in the TEC.

The permitted load on the relays is the same as on the output terminals of the control and output board.

Permitted load (breaking capacity) on output terminals, see section 3.3.7.1 Control and output board (TC 160).

3.4.3 Alarm box TC 181

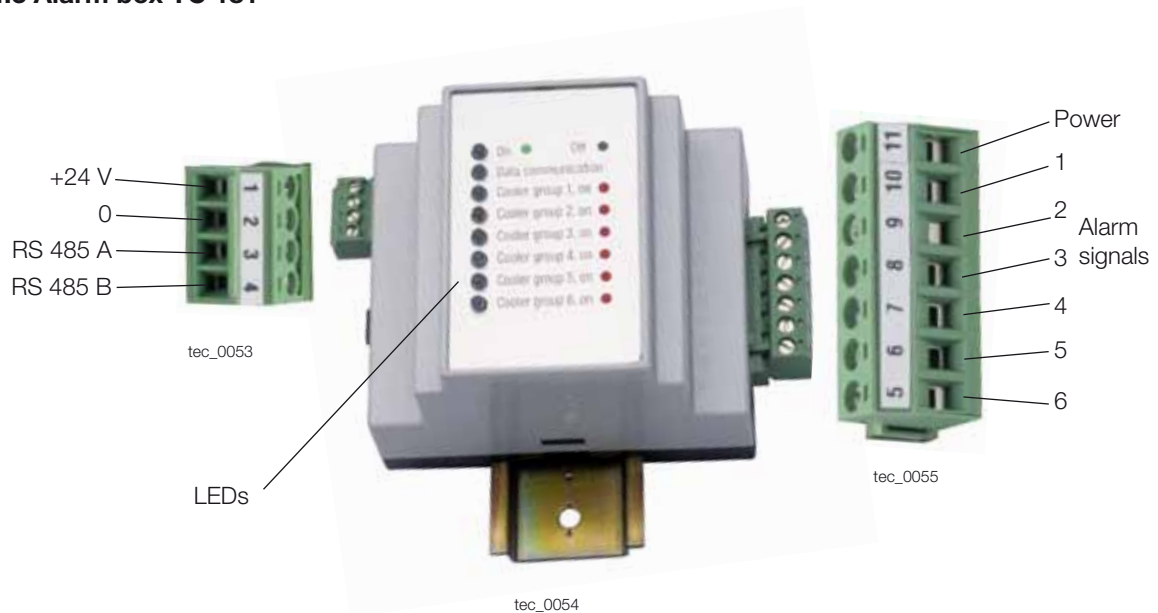

The alarm box can be used to obtain dry contact output from specific alarms in the TEC. A maximum of 2 alarm boxes can be used. No connection should be made to unused signals.

A closed relay is represented by a lit LED.

The alarm boxes can be placed in either the transformer control cabinet or in the TEC unit.

The power supply and RS 485 communication can be wired in parallel with the motor relay box. A separate power supply can be used.

3.5 Performed tests

3.5.1 EMC (Electro Magnetic Compatibility) tests

Immunity according to EN 61000-6-2:1999

Radiated RF field	IEC/EN 61000-4-3 (1995), ENV50204 (1995)
Conducted RF voltage	IEC/EN 61000-4-6 (1996)
Fast transient/burst	IEC/EN 61000-4-4 (1995)
Electrostatic discharge (ESD)	IEC/EN 61000-4-2 (1995/96)
Surge	IEC/EN 61000-4-5 (1995)
LF magnetic field¹	IEC/EN 61000-4-8 (1993)

Additional immunity tests

Damped Oscillatory Wave¹	IEC/EN 61000-4-12 (1995), SS436 15 03
Spark¹	SS436 15 03
Power voltage variations¹	IEC SC77AWG 6 (info. Annex)

Emission according to EN 50081-2:1993

Radiated emission	CISPR 11 (1997), EN 55011 (1998)
Conducted emission	CISPR 11 (1997), EN 55011 (1998)

1) This method is not within the scope of the laboratory accreditation.

Emission	Port	Class	Limits	Result¹
Radiated emission	Enclosure	A	limits of EN 55011 increased by 10 dB for 10 m measured distance in accordance with EN 50081-2	Passed
Conducted emission	AC mains	A	limits of EN 55011	Passed

Immunity	Immunity port	Process I/O ports	Mains port	Earth ports	Result/ Criteria¹
Radiated RF fields	15 V/m	-	-	-	Passed/A
Conducted RF voltage	-	10 V	10 V	10 V	Passed/A
Electrostatic discharge	8 kV contact 15 kV air	4 kV	4 kV	4 kV	Passed/A
Surge pulse	-	4 kV (CM)	4 kV (CM) 2 kV (NN)	-	Passed/A
Power frequency magnetic field	1000 A/m	-	-	-	Passed/A
Power voltage variations	-	-	-/+ 10%, 15 s	-	Passed/A
Damped oscillatory wave	-	2.5 kV	2.5 kV	-	Passed/A
Fast transient/spark	-	4 kV - 8 kV	4 kV - 8 kV	-	Passed/A

1) Passed = Complied with the specification.

Failed = Did not comply with the specification. See relevant chapter for details.

Criteria, see chapter 4.4 Criteria for approval.

3.5.2 Mechanical tests, vibration and seismic

The TEC unit manufactured by ABB in Sweden has been subjected to mechanical testing as specified in chapter 3.

The results of this testing are presented below:

Test	Specifications	Severity	Result
Vibration	IEC 60255-21-1 IEC 60068-2-6	10-150 Hz, 2 g, 20 sweep cycles	OK
Bump	IEC 60255-21-2 IEC 60068-2-29	10g, 16 ms, 6 x 1,000 bumps	OK
Shock	IEC 60255-21-2 IEC 60068-2-27	15 g, 11 ms, 6 x 3 shocks	OK
Seismic	IEC 60255-21-3 IEC 60068-2-6	1-35 Hz, 7.5 mm/2 g, 1 sweep	OK

1) OK: No malfunctions were observed during the test and no damage was observed after the test.

3.5.3 Climate tests

Test		Severity	Duration	Standard
Dry heat	Operational	+85°C	72 hours	IEC 60068-2-2, Test Bd
Cold	Operational	-40°C	72 hours	IEC 60068-2-1, Test Ab
Change of temperature	Operational	-40 to +70°C	3 cycles t = 2 h 3°C/min	IEC 60068-2-14, Test Nb
Damp heat steady state	Operational	+40°C, >93% non-condensing	4 days	IEC 60068-2-3, Test Ca
Damp heat cyclic	Operational	+25 to +55°C, >93% condensing	6 x 24-hour cycles	IEC 60068-2-30, Test Dd

3.5.4 Fiber-optic converter TC190 tests

3.5.4.1 EMC tests

Immunity according to EN 61000-6-2:2001

Radiated RF immunity:	EN 61000-4-3 ed. 2 (2002) ENV50204 (1995)
Conducted RF immunity:	EN 61000-4-6 (1996) + A1 (2001)
Fast transient/burst:	EN 61000-4-4 (1995) + A1 + A2 (2001)
Electrostatic discharge (ESD):	EN 61000-4-2 (1996) + A1 (1998)
Surge pulse:	EN 61000-4-5 (1995) + A1 (2000)

Additional immunity tests

Damped Oscillatory Wave ¹⁾:	IEC/EN 61000-4-12 (1995), SS436 15 03
---	---------------------------------------

1) This test method is not within the scope of the laboratory accreditation.

Emission according to EN 61000-6-4:2001

Radiated RF emission:	CISPR 11 (1997), EN 55011 (1998) + A1 (1999) + A2 (2002)
------------------------------	--

3.5.4.2 Climate tests

Operational tests

Test	Test equipment	Severity	Duration	Standard
Cold	In operation	-10°C	16 hours	IEC 60068-2-1, Test Ad
Dry heat	In operation	+55°C	16 hours	IEC 60068-2-2, Test Bd
Damp heat (steady state)	In operation	+40°C > 93 % non-condensing	4 days	IEC 60068-2-78, Test Cab
Change of temperature	In operation	+5°C to +55°C	3 cycles 3°C/minute t = 1 h	IEC 60068-2-14, Test Nb

Storage tests

Test	Test equipment	Severity	Duration	Standard
Cold	In storage	-40°C	96 hours	IEC 60068-2-1, Test Ab
Dry heat	In storage	+70°C	96 hours	IEC 60068-2-2, Test Bb

3.6 Trip, alarm, and warning output from TEC

3.6.1 Output signals from TEC cabinet

NOTE: Terminal numbers for TEC Basic only.

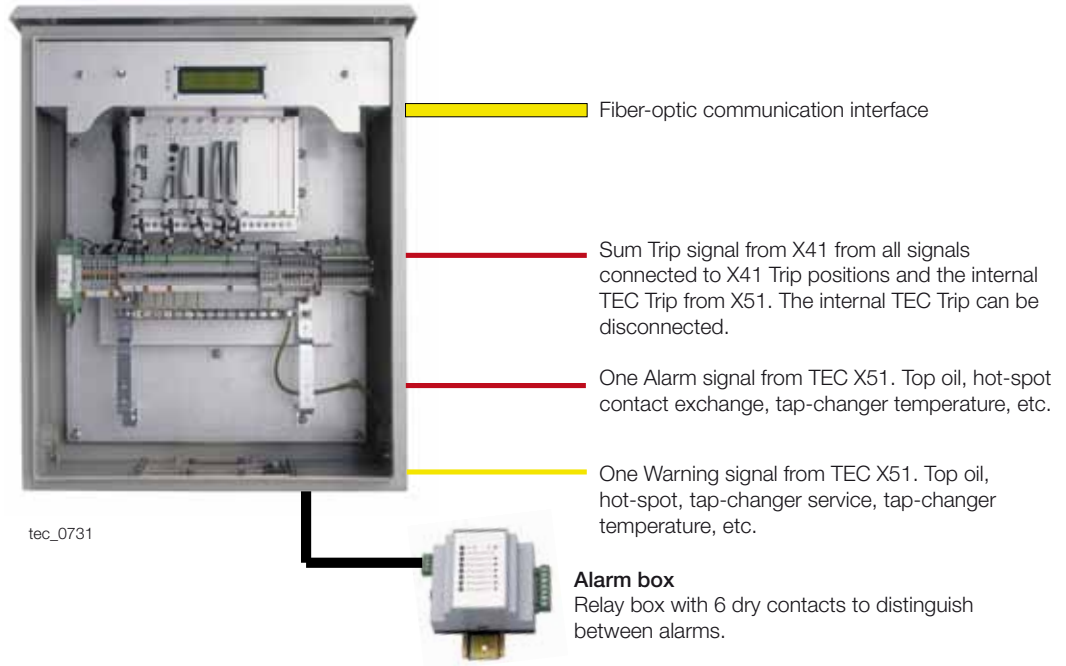

tec_0731

3.6.2 Alarm/Warning output options

Alarm/Warning option 1

The devices connected to the TEC will provide an alarm signal from X51:11 and X51:12 and a warning signal from X51:10 and X51:12. Alarms and warnings from TEC functions will also be connected to these contacts. The optional TC 190 provides the potential to send, via fiber-optic cable, details about the alarm and warning signals from the devices and the TEC event log to a PC.

Option 1, TEC option

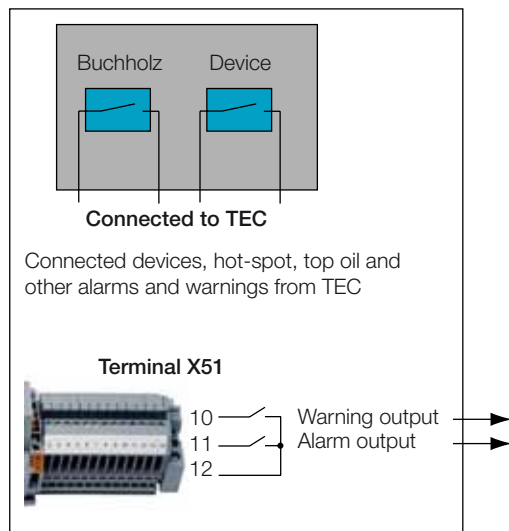

tec_0732

Substation control

- 2 cables for Alarm and Warning from TEC
- Gets an Alarm or Warning from contacts
- Gets an Alarm or Warning from TEC
- Details found in TEC

Alarm/Warning option 2

No devices connected to TEC. Alarms and warnings from TEC functions will have the alarm signal from X51:11 and X51:12 and the warning signal from X51:10 and X51:12. The optional TC 190 provides the potential to send, via fiber-optic cable, details about the alarm and warning signals from the TEC event log to a PC.

Option 2, TEC option with traditional contacts

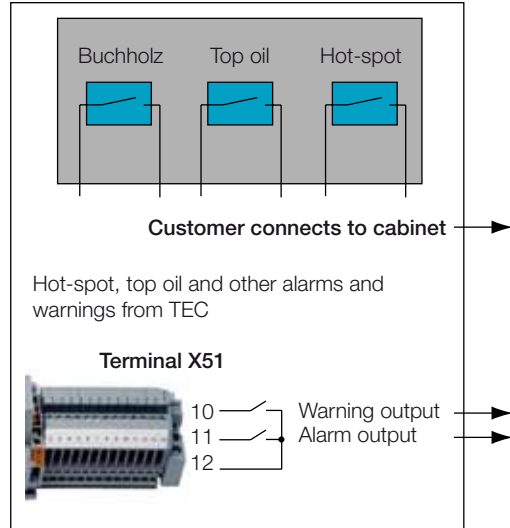

Substation control

- 2 cables for Alarm and Warning from TEC
- Cables from all protection devices
- Gets an Alarm or Warning from TEC
- TEC gives details from TEC Alarm/Warnings

tec_0733

3.6.3 Trip output options

Trip option 1

No trip devices connected to TEC. Trip signals from TEC functions use X41:26 and X41:29. The customer connects this signal the same as any other device. The optional TC 190 provides the potential to send, via fiber-optic cable, details about the trips in the TEC event log to a PC.

Trip option 2

No trip devices connected to TEC. Trip from TEC functions not used. No information about the trips in TEC event log.

Option 1 with TEC trip device from TEC

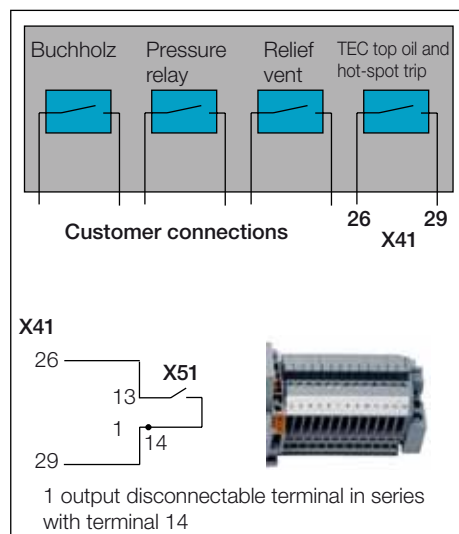

tec_0734

Option 2 as today on transformer

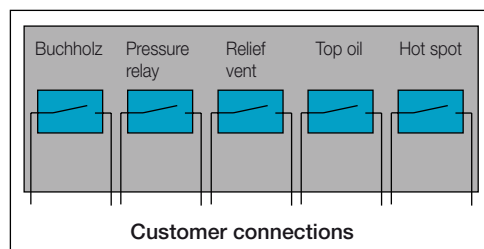

Substation control

- 1 cable for Trip from TEC (option 1)
- Cables from all protection devices
- TEC gives details from TEC Trip (option 1)

Trip option 3

Trip devices connected to the TEC will provide a trip signal on X41:26 and X41:29. If the TEC trip is disconnected from terminal X51:1, this signal will not be integrated in the trip sum signal. The optional TC 190 provides the potential to send, via fiber-optic cable, details about the trip signals from the devices and the TEC event log to a PC.

Trip option 4

Trip devices connected to the TEC and the internal TEC provide one trip signal on X41:26 and 29. The optional TC 190 provides the potential to send, via the fiber-optic cable, details about the trip signals from the devices and the TEC event log to a PC.

Option 3 TEC solution

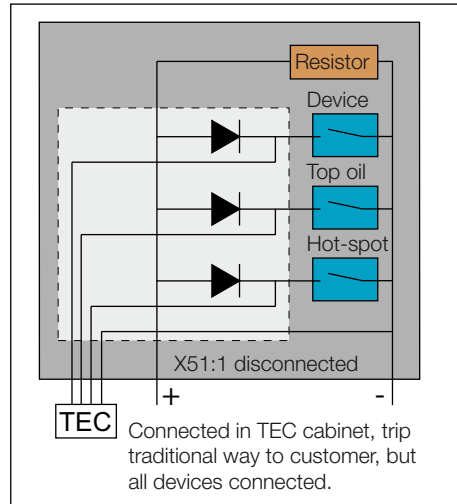

Substation control

- 1 cable for Trip from TEC
- TEC gives details for all Trip

Option 4 TEC solution with TEC trip device

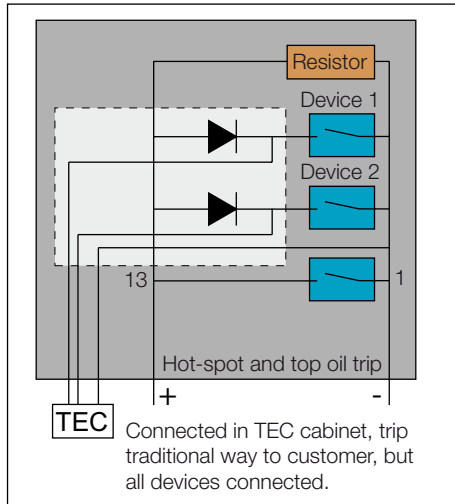

tec_0735

Substation control

- 1 cable for Trip from TEC
- TEC trip included
- TEC gives details for all Trip

3.6.4 Connection of devices in parallel both traditionally and to TEC

Alarm/Warning devices

The figure below shows how alarm/warning devices can be connected the traditional way in parallel with the TEC. If the voltage in the station alarm/warning circuit is >24 V, no diode is needed in the traditional alarm/warning circuit.

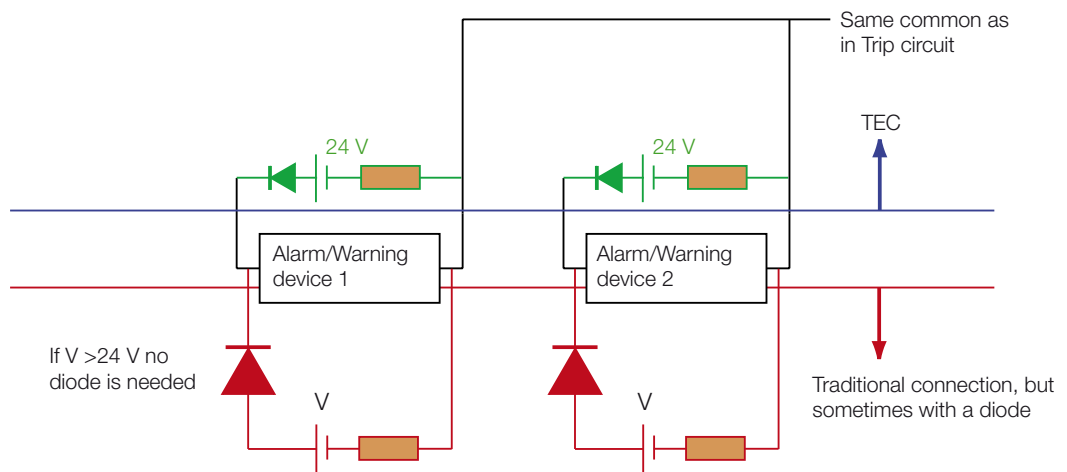

tec_0736

Trip devices

The figure below shows how warning/alarm devices can be connected the traditional way in parallel with the TEC. Note that a diode is needed in the traditional trip circuit.

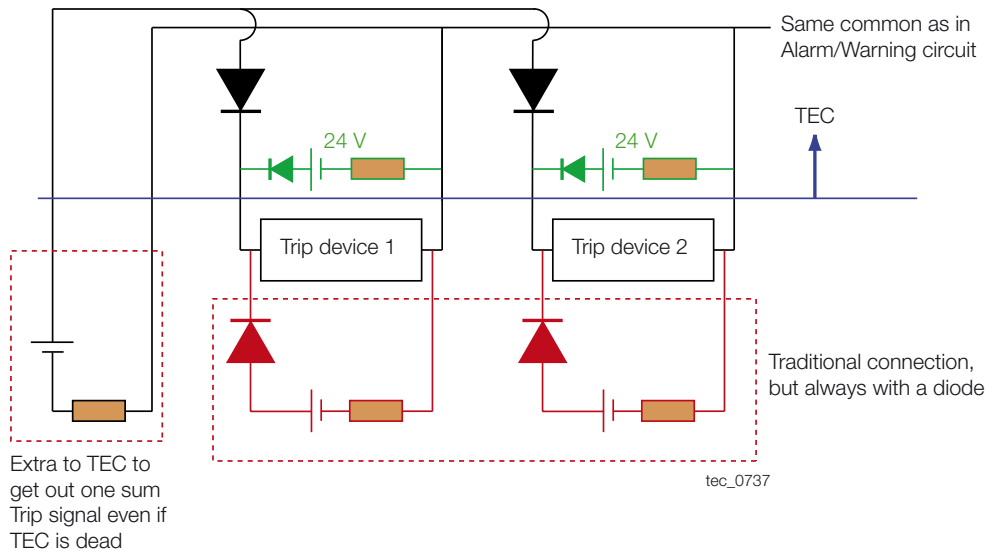

4. Software

The following functionality is available in TEC and is described in this chapter:

- Transformer status
- Winding hot-spot temperature calculation
- Moisture content and bubbling temperature
- Cooling control
- Thermal ageing
- Overload capacity
- Short overload capacity
- Hot-spot forecast
- Tap-changer contact wear
- Hydrogen
- Moisture in transformer and tap-changer
- Transformer temperature balance
- Tap-changer temperature balance
- On-site configuration
- Event handling
- Communication
- Configurable inputs.

4.1 Transformer status

The display and the main page of the web interface show the present status of the transformer. They show both the values of some important parameters and the overall status, symbolized by a small flashing Warning, Alarm, or Trip indicator. The transformer history can also be displayed in the web interface. The history that is shown in the graphs will be stored with 10 minute intervals for 56 weeks.

The basic system values displayed are described below.

The web interface shows the status of the transformer.

- The screen below shows the current status of the transformer.
- Historical data can be displayed in charts.
- Small flashing indicator signs (one for each event) appear to the left/right of the affected value field as well as on the quick tabs.
- The language used on all TEC screens can be switched between the two pre-configured languages (Native and English).
- Connection to the TEC is possible from a PC with Internet Explorer® 6 or later, or Mozilla Firefox 2 or later.
 - The TEC can easily be connected to a LAN.
 - The TEC can be connected to a modem for access over the phone.

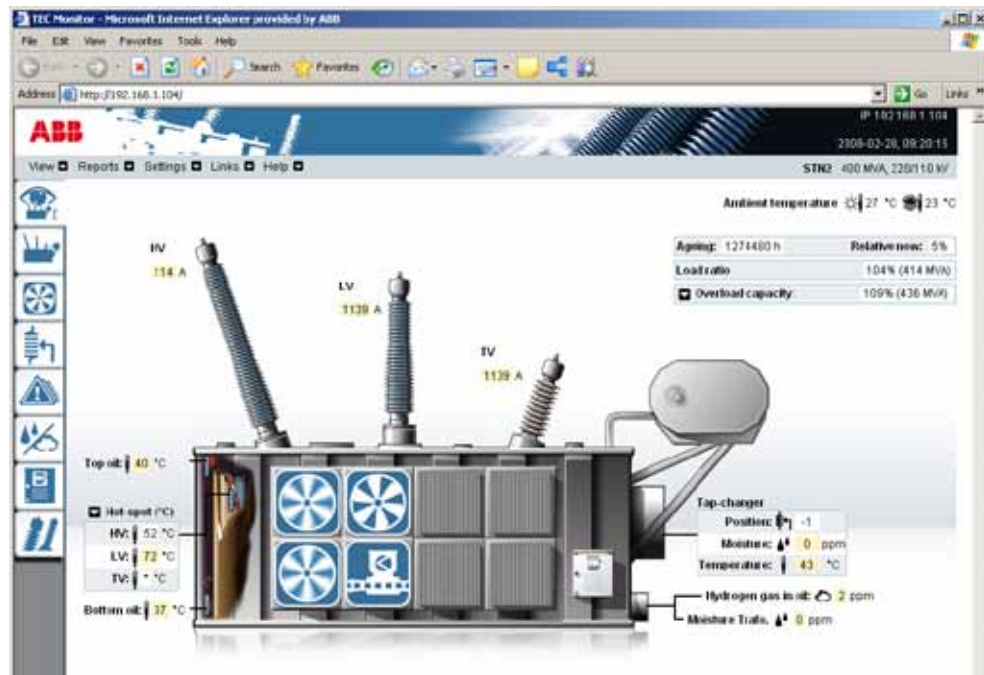

tec_0600

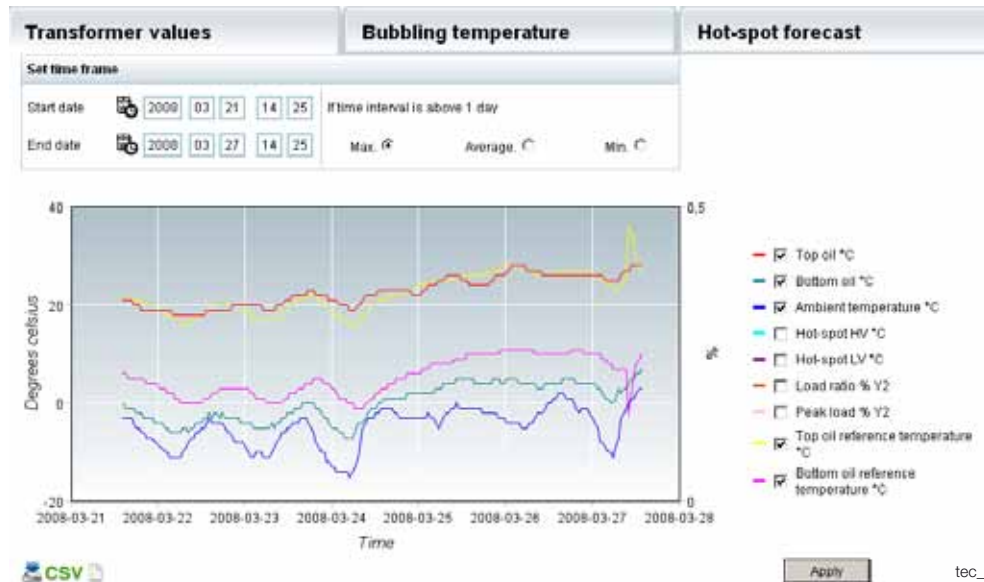

4.1.1 Transformer top and bottom oil temperature

The transformer top and bottom oil temperature is measured and displayed.

4.1.2 Current measurement

The currents from the transformer CTs are used to calculate the current in the windings and bushings. It is the bushing current that is displayed in the interface. The highest load is used to indicate the load of the transformer. The accuracy of the current measurement is approximately 3% of full load.

4.1.3 Tap-changer temperature

The temperature in the tap-changers is measured. The historical measured temperature can easily be compared with the transformer and outdoor temperatures in the web interface to check that the situation is stable. The same chart can also display the load.

4.1.4 Tap-changer position

This function keeps track of the tap-changer position.

4.1.5 Voltage measurement

The voltage in the transformer can be connected to the TEC unit. The 85-145 V signal must come from an external device.

4.2 Hot-spot calculation

The winding hot-spot is calculated to fulfill both IEC and IEEE.

- The hot-spot calculation can be made for up to 3 windings. The hot-spot calculations are made without the normal time delay (≈ 6 min) to enable quicker cooling initiation.
- The values will be shown on the display and in TEC Monitor. Historical values can also be displayed in the TEC Monitor.

4.3 Cooling control

The cooling control can be used for both cooler and radiator cooled transformers. Enhancements over traditional cooling are:

1. TEC can control up to 6 cooler groups.
2. Starts on top oil, hot-spot, and forecast.
3. All cooler groups used through permutation.
4. All cooler groups are started every week.
5. Time in service shown in the station interface.
6. Time delay between motor start.
7. Fail-safe operation.

1. TEC can control up to 6 cooler groups

This makes it possible to run the cooling in up to six steps instead of the normal two steps. This will:

- Reduce the noise level
- Keep the transformer temperature at a more stable level and reduce breathing.

2. Starts on top oil, hot-spot, and forecast

The cooling will be controlled by:

- Top oil temperature
- Hot-spot temperature
- Calculated forecasts for the hot-spot and top oil temperatures based on actual load and ambient temperature. All cooler groups will start if the calculated steady state temperature is warmer than needed to start all cooler groups.
- Manual start of cooler groups from the web interface

It is also possible to configure cooler groups that are started on the basis of top oil and hot-spot temperatures outside of the TEC's normal control system

It is possible to change the cooler control settings from the web interface after delivery of the TEC unit.

3. All cooler groups used through permutation

When a cooler group is to be started, the TEC always starts the one that has been used the least amount of time.

4. All cooler groups are started each week

Each week all cooler groups are run for 10 minutes. After the 10 minutes, the cooler groups with the least service time will continue to run if cooling so requires. This is done to prevent coolers remaining unused for an extended period of time. Motors that are not used can experience problems, for example, with corrosion or damaged ball bearings.

5. Time in service shown in station interface

The time that the cooler groups have been in service is displayed in the station interface. This can be used to plan cooling equipment servicing.

6. Time delay between motor start

There is a 10-second time delay between cooler groups starting. This is to prevent:

- A current peak in case the original power supply has failed and a back-up supply has been started.
- A pressure pulse from the pumps that could affect pressure protection devices in the transformer tank.

7. Fail-safe operation

The TEC will start a new cooler group in cases where the TEC has tried to start one cooler group but not received any feedback that the group is running within 1 minute. The TEC will also generate a warning with the text below.

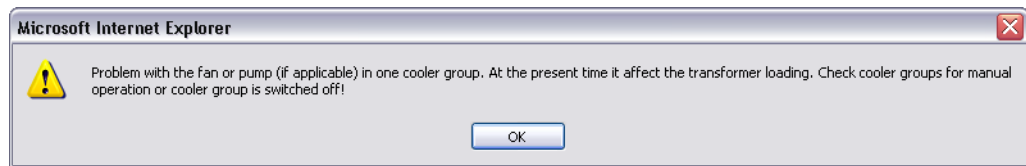

tec_0694

In cases where a cooler group is not working and no extra group is available, an Alarm is generated and the TEC will display the following message.



tec_0695

If the TEC fails or if it is not sending any commands to the cooler control box, then the control box will enter a mode where all cooler groups are started. If the TEC then returns to normal service, it automatically takes over from the cooler control box. The cooler control box should be placed adjacent to the cooler group contactors.

If neither the TEC nor the cooler control box works, then the traditional top oil thermometer should start all coolers at a preset temperature.

4.4 Ageing

The ageing due to heat at the winding hot-spot can be calculated for non-thermally upgraded paper (according to IEC) or thermally upgraded paper (according to IEEE). The accumulated and actual ageing will be shown in the web interface. The accumulated ageing can be used to compare the ageing between different transformers. It can be used in decisions about transformer overloading or replacement.

4.5 Overload capacity

The transformer's overload capacity is shown in the web interface. The overload capacity indicates the load conditions under which the transformer can be operated without exceeding the preset top oil and hot-spot temperatures. It is based on a transformer temperature model with the specific transformer's fingerprint data and real-time measurements as inputs.

4.6 Short-time overload capacity

The basic idea is to know how much the transformer can be loaded for a certain time without exceeding the limit. The time scopes are 15 minutes, 30 minutes, 1 hour and 2 hours. When the limit is exceeded there will be some capacity left, if the load is reduced. In most cases, when the ambient temperature is high, and the different limits are used for hot-spot and top oil, then it is possible the top oil temperature hits the limit first.

The overload capacity is the calculated load, which makes the hot-spot temperature rise to the maximum allowed temperature in a specific time. If the hot-spot temperature exceeds the maximum allowed temperature, the overload capacity is the load which immediately reduces the hot-spot temperature to the maximum allowed temperature. If the top oil temperature exceeds the maximum allowed temperature, the overload capacity is zero, because there is no more capacity left.

Ambient temperature ☀️ 27 °C 🌙 22 °C

Ageing: 1274490 h	Relative now: 5%
Load ratio	104% (41 MVA)
<input checked="" type="checkbox"/> Overload capacity:	109% (44 MVA)
🕒 15min	146% (59 MVA)
🕒 30min	137% (55 MVA)
🕒 60min	126% (50 MVA)
🕒 120min	116% (47 MVA)
<input checked="" type="checkbox"/> Top oil trend	11 K/h

tec_0627

NOTE: No overload capacity load is allowed to exceed 150%, because the capacity limits at other equipment like the tap-changer.

4.6.1 Overload signals

There are two overload signals: overload in 5 minutes and overload in 0 minutes. The first signal is based on a five minute forecast, and it will be activated when it predicts that the hot-spot temperature will exceed the limit within 5 minutes. The second signal will be activated when the hot-spot has exceeded the limit. Both signals will remain until the hot-spot temperature gets three degrees lower than the limit.

4.6.2 Top oil trend

The temperature speed is a calculated average temperature speed (K/h) of the top oil temperature at the current load ratio, based on a 15 minute forecast. If the temperature speed is close to zero, the transformer can be considered to have entered a steady state.

4.7 Hot-spot forecasts

The hot-spot forecast provides a prediction of the transformer temperature under the configured load conditions.

The thermal algorithms for the calculations are based on IEC, although the same method is also used in IEEE. The parameters used in the algorithms are the specific transformer fingerprint values. The actual measured temperature values from the TEC are used as start values. See the *User's Manual* for details, which also contains recommendations on overloading from both IEC and IEEE.

By specifying the two loading ratios for the next ten hours, the predicted hot-spot can be calculated over that period. The thermal ageing during the overloading is also displayed.

The hot-spot temperature is calculated from the load at "First step" until it reaches the "Max hot-spot value".

When the "Max hot-spot value" has been reached, the hot-spot calculation is based on the load at "Second step".

It is also possible to change:

1. Ambient temperature; to see its influence on the hot-spot
2. Cooling capacity; to see the effect of reduced cooling capacity
3. Max hot-spot First step.

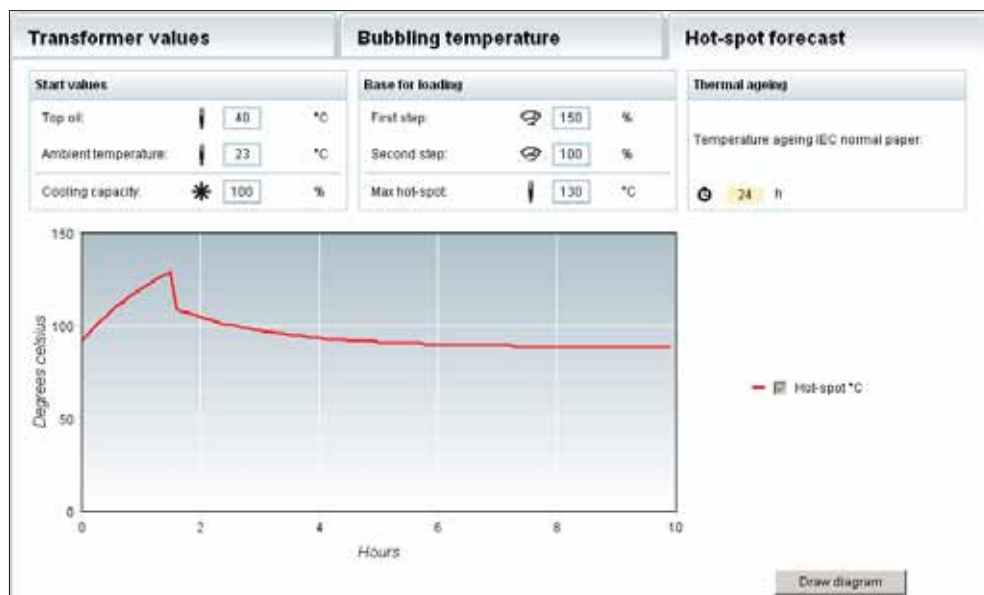

4.8 Tap-changer contact wear

The contact wear function keeps track of the wear on each contact during operation, and calculates how much material has been worn off. From this information it calculates operating time and time to next service/contact replacement. As these events approach, warnings are provided, and if actions are not taken in due time, alarms are generated. This function should be used as a forecaster and reminder for when overhaul and contact replacement is required. This is especially important for transformers with frequent tap-changer use, where more regular service is required. Instead of performing service based on operations (1/5 of the contact life), the TEC estimates when 1/5 of the contacts are worn. This can prolong the time between servicing without jeopardizing tap-changer functionality. It should be noted that there are also time-based service intervals.

Tap-changer type: UZ



tec_0620

4.9 Hydrogen

The TEC unit can register and store data if a hydrogen sensor is placed on the transformer. With the TEC it is possible to see:

- The present value in the transformer overview screen
- How the hydrogen content changes over time in charts.

The transformer load can also be displayed in the charts, making it possible to see whether the changes in hydrogen content are load-dependent. If the hydrogen content is load-dependent, this indicates an overheating problem.

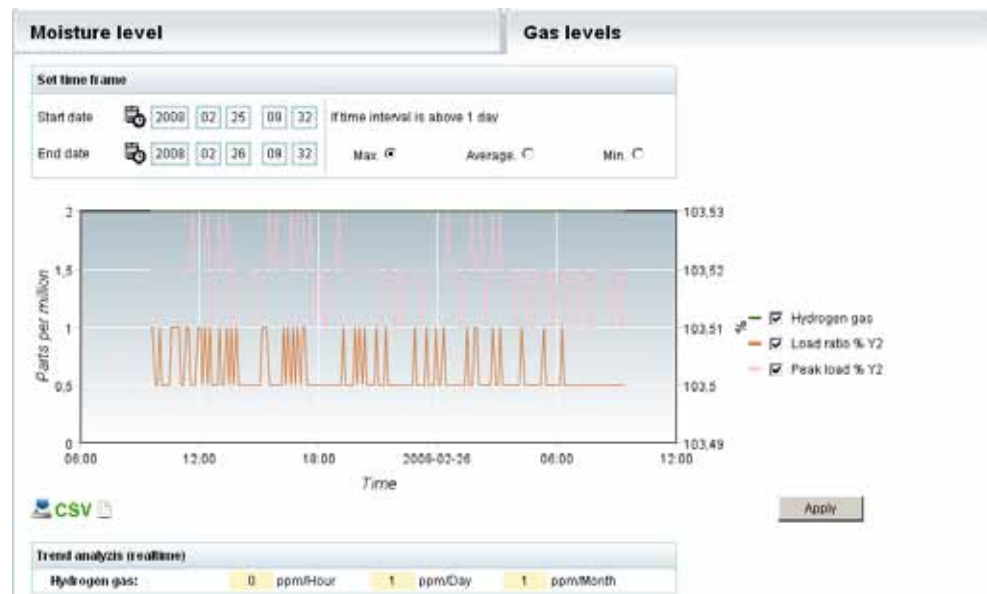

tec_0625

The screen also displays the current trends calculated in:

- ppm/hour (for short-term trend)
- ppm/day (for medium-term trend)
- ppm/4-week (for long-term trend).

In most cases, the important information is the trend of the hydrogen equivalent and not the absolute readout.

In some equipment, such as HYDRAN®, the hydrogen content is specified as a hydrogen equivalent that includes the H₂ (hydrogen) content and fraction of the other hydrocarbons, such as C₂H₂, C₂H₄, etc., and also consists of parts of the CO (carbon monoxide) content in the transformer oil. Other suppliers have equipment that only measures the hydrogen content in the oil. Please check the manual of the hydrogen detector installed on the transformer for more details. If needed, the sensor can be calibrated from the web interface. For more information, see the *Maintenance Guide*.

4.10 Moisture content in the transformer and tap-changer oil

The TEC unit can register and store data if a moisture sensor is placed on the transformer or the tap-changer. It can calculate the moisture content in the transformer oil in ppm if preferred to relative humidity or water activity. No display is needed on the moisture sensor as the values are shown on the TEC display and in the web interface. Historical values are displayed in the web interface. Any increase in moisture content in the transformer can be seen in the charts.

For the tap-changer the moisture content in oil is the most important reason for service at certain time intervals.

4.11 Transformer temperature balance

The transformer temperature balance is a thermal model of the specific transformer that can be compared with the measured values and indicates cooling system performance. It can also indicate whether there is excessive heat in the transformer. The calculated top and bottom oil reference values are compared with the measured value to detect trends.

The transformer top and bottom oil temperature calculations are based on:

- Load conditions
- Ambient temperature
- Cooler groups running
- Transformer fingerprint parameters.



tec_0631

4.12 Tap-changer temperature balance

The tap-changer temperature balance is a thermal model of the specific transformer and tap-changer that can be compared with the measured tap-changer temperature values. In cases of excessive heat generation in the tap-changer over a longer period, this clearly indicates a fault in the tap-changer.

The tap-changer oil temperature calculation is based on:

- Load
- Heat from switching operations
- Ambient temperature
- Transformer temperatures
- Fingerprint parameters.



tec_0632

4.13 On-site configuration

Some configuration can be performed on-site. New sensors can be connected to the TEC after delivery. Warning and alarm levels, as well as some other data, can be changed after delivery. The cooling system parameters are also easily changed.

The information in the display is easily configured from a PC to show other available information.

4.14 Event handling

There are four types of event level in the TEC system.

- **Note** events are used for indication type activities and can, for example, be used to indicate that the TEC or transformer door is open.
- **Warning** events are an indication that something minor has happened that could develop into a more severe problem, such as the top oil starting to heat up. They also indicate sensor malfunctions. A warning results in a small flashing Warning sign to the left/right of the affected value field on the Overview as well as on the affected quick tabs.

- **Alarm** events indicate a serious problem with the transformer or the TEC system. For example, an alarm event is generated when the top oil temperature climbs to a dangerous level. The recommendation is to examine the cause and evaluate the situation. An alarm results in a small flashing Alarm sign to the left/right of the affected value field on the Overview as well as on the affected quick tabs.
- **Trip** events indicate severe problems with the transformer. The recommendation is to power down the transformer and examine the cause. A trip indication results in a small flashing Trip sign to the left/right of the affected value field on the Overview as well as on the affected quick tabs.

4.14.1 Event list

The events are shown in the event list in the graphic interface and on the local display. In the web interface the order of events can be seen with a resolution of 1 ms.

Lista över aktiva händelser (5 totalt)
 Lista över alla händelser (500 totalt)
 1 (1) (senaste)

Välj	Händertid	Händelstyp	Funktion	Beskrivning	Åtgärd väntagen den
<input type="checkbox"/>	2008-02-22, 10:41:40.737	Alarm	Kylning	Oblräcklig kylkapacitet	(Åtgärd väntas)
<input type="checkbox"/>	2008-02-22, 09:58:01.720	Varning	Kylning	Kylargrupp 1 ej aktiv	(Åtgärd väntas)
<input type="checkbox"/>	2008-02-22, 09:50:01.720	Varning	Kylning	Kylargrupp 2 ej aktiv	(Åtgärd väntas)
<input type="checkbox"/>	2008-02-18, 12:02:41.802	Alarm	Kylning	Förlust av kommunikation till kylarkontrollbox	(Åtgärd väntas)
<input type="checkbox"/>	2007-12-12, 08:35:27.501	Sensorfel	Skydd	Ölmsensor högspänningsledning	(Åtgärd väntas)

Åtgärd utförd av:

tec_0608

Once the cause of an event has been remedied, the event signal can be deactivated from the web interface. Deactivated events are stored, with space for more than 3,500 events in the unit.

4.14.2 Protection

The TEC system can generate relay output signals for the protection of the control system. The outputs are dependent on events, either internal or external, and can be individual or grouped.

All external protection devices can be connected to the TEC. All connected devices appear in the TEC event list. They will also be part of the signals for the dry contacts representing Trip, Alarm, and Warning. External Trip signals will be galvanically connected in the TEC terminals so that the sum Trip signal will be sent from the TEC cabinet even if the TEC is switched off.

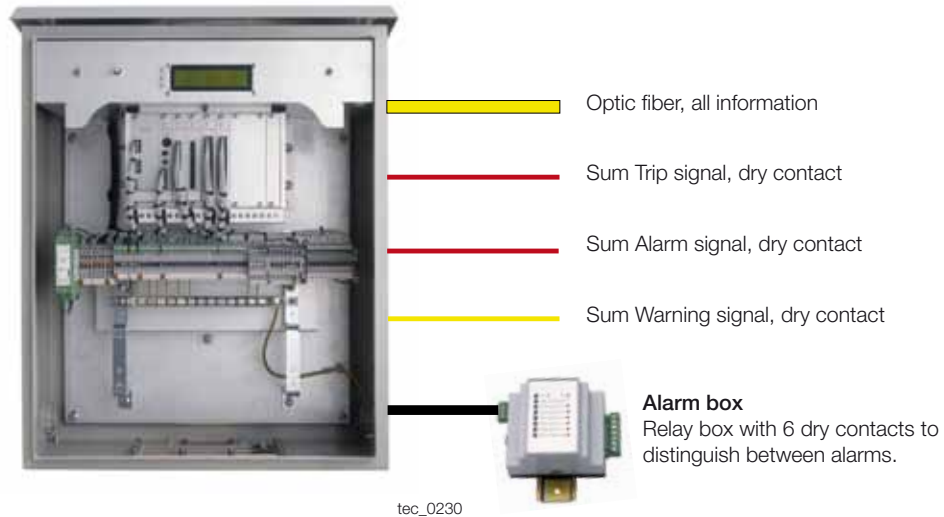

4.14.3 Sensor backup

There is a sensor back-up in the TEC in case of sensor failure. If the reading from a Pt100 sensor is out of range (-50 – 150°C) for 1 minute, a back-up will take place as described below. A Warning will be given and the name of the failed sensor displayed in the event list. If the Pt100 sensor is replaced it will start to work after approximately 30 seconds.

If a 4–20mA sensor is out of range, i.e. the reading is <3.5 mA or >22 mA, a Warning is given and the name of the failed sensor is displayed in the event list. The false sensor reading will not be displayed. If the sensor is replaced it will start to work after 30 seconds. For the current sensors, see also the logic below.

Top oil thermometer failure

If the sensor fails, the top oil temperature is calculated based on the bottom oil temperature. Under stable conditions the calculated temperature will be relatively close to the actual temperature. During rapid load increases, however, the calculated top oil temperature will increase much more quickly than the actual temperature. **To avoid a premature trip in such cases, the top oil trip is disabled, although the alarm and warning signals will still work.** A sensor failure warning will be generated.

$$\Theta_{\text{Top}} = \Theta_{\text{Bot}} + 2[\Delta\Theta_{\text{imr}} - \Delta\Theta_{\text{br}}]K^Y$$

Bottom oil thermometer failure

If the sensor fails, the bottom oil temperature is calculated based on the top oil temperature. A sensor failure warning will be generated.

$$\Theta_{\text{Bot}} = \Theta_{\text{Top}} - 2[\Delta\Theta_{\text{imr}} - \Delta\Theta_{\text{br}}]K^y$$

Both top and bottom oil thermometers fail

If both sensors fail, a sensor failure alarm will be generated in the TEC.

Ambient air thermometer failure

If the shade sensor fails, the value from the sun sensor will be used for the calculations. If the sun sensor fails, the value from the shade sensor will be displayed.

If one sensor fails, a warning is given. If both sensors fail, a warning is still given and the sensor outputs prior to failure are displayed.

Current sensors

There are three different types of behavior in the case of sensor errors.

A two-winding transformer sensor error will be compensated by the calculation of the faulty current, based on the other current sensor. The calculation is based on the remaining current, the transformer ratio, and the tap-changer position.

For all other connection types there will not be any current calculation. The faulty sensor will display “**”.

For autotransformers a current sensor failure on the series winding will result in a current reading of “**” from both current sensors. If the current sensor on the LV side or common winding fails, the output from this sensor will be “**”, but the output from the series current sensor will be correct.

If one current sensor fails, a warning is given. If both sensors fail, an alarm is generated.

4.14.3.1 Effect of sensor failure on functions

Hot-spot temperature calculation

The hot-spot temperatures for the high-voltage and low-voltage windings are always calculated. If a thermometer or current transformer sensor fails, the lost value will be calculated by the formulas in the previous sections and will be used for the hot-spot calculations.

Ageing

If the hot-spot temperature of the hottest winding cannot be calculated due, for example, to a current transformer failure, the second hottest winding will be used for the ageing calculation.

Cooling control

If the hot-spot temperature of the hottest winding cannot be calculated due, for example, to a current transformer failure, the second hottest winding will be used for cooling control.

4.14.4 Message boxes

In the case of Trip, Alarm, or Warning conditions, a message box will also appear in the TEC under the icon button with the problem. The message box provides more information about the reason for the alert and recommendations for action.

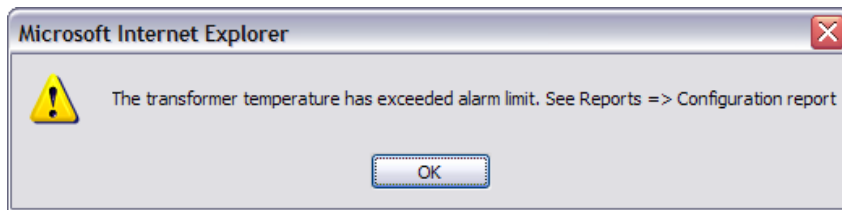

tec_0676

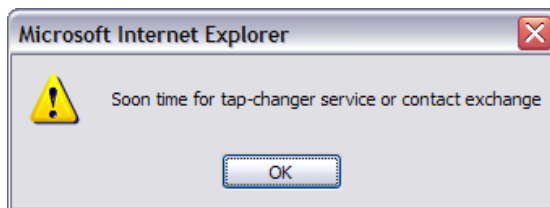

tec_0669

4.15 Cabinet conditions

This function reads the temperature and the relative humidity on the processor board in the cabinet.

The temperature is monitored, as a high temperature is the main cause of ageing electronics. The TEC is designed to provide low temperature electronics. To further prevent ageing some of the components are thermally upgraded.

The moisture content is monitored even though the boards are coated to resist moisture. The readings will be available as both present conditions and a histogram showing the frequency of the different temperatures and humidity levels.

4.16 Communication

The TEC system can simply be connected to a LAN network and viewed from a standard computer with Internet Explorer® 6 or later, or Mozilla Firefox 2 or later. No additional software is required. The system can also be connected to a modem for access over the phone. There are different levels of password protected access in the web interface.

The TEC system can communicate with external systems using three different methods: Dry contacts, OPC, and XML files.

4.17 Configurable inputs

The TEC system is based on a modular structure, which makes it possible to add additional sensors. It is possible to add any 4-20 mA, Pt100, or digital devices.

For other types of sensor, for example CAN bus sensors, contact ABB. The extra sensor values will be stored and the signal event levels can be configured.

4.18 Ordering data

The specification of the TEC system is provided by filling out a Microsoft Excel® order data sheet. The order sheet defines the connections for the TEC system. It also provides a fingerprint setting of the transformer.

For more information, see the *Ordering data guide*.

4.18.1 Load test

In the event data from the transformer's heat-run test deviate from calculated values given in section 2.21 Ordering data, the new values must be added to the transformer model in the TEC.

5. Installation

For more information, see the *Installation and Commissioning Guide*.

Input parameters

- 8 insulated analog 4-20 mA inputs via terminals (expandable up to 24)
- 4 insulated Pt100 direct inputs (expandable up to 16)
- 1 input for the voltage measurement (85-140 V)
- 1 input for tap-changer position, resistor bridge ($R_{\text{tot}} \geq 80 \Omega$ or $R_{\text{step}} \geq 10 \Omega$).
- 12 insulated digital inputs* by terminals (expandable up to 48)
- CAN bus possibility, contact ABB
- PPS/PPM synchronization pulses.

Output parameters

- 5 output relays*, fast (ms) relays, 3 used for warning alarm and trip
- Up to 12 output relays*, slow (s) relays
- Up to 6 outputs relays* for cooler control relays.

* Permitted load breaking capacity on output terminals AC 250 V 8 A, DC 250 V 0,1 A L/R=40 ms, DC 30 V 5 A

5.1 Sensors

Sensors can be included in the delivery. For more information, see the *Ordering data guide*.

Connection of the cable shield is described in section 4.2 *Cables and earthing*.

5.1.1 Air temperature

A Pt100 sensor for air temperature in sun and shade. The sensor in the shade must not be affected by heat radiated from the transformer.

A Pt100 sensor that is replaced automatically starts to work after approximately 30 seconds.

The bushing that is included in the delivery is for a cable diameter of 4–8 mm. If a larger cable diameter is used it should be provided by the customer.

Temperature input Pt100

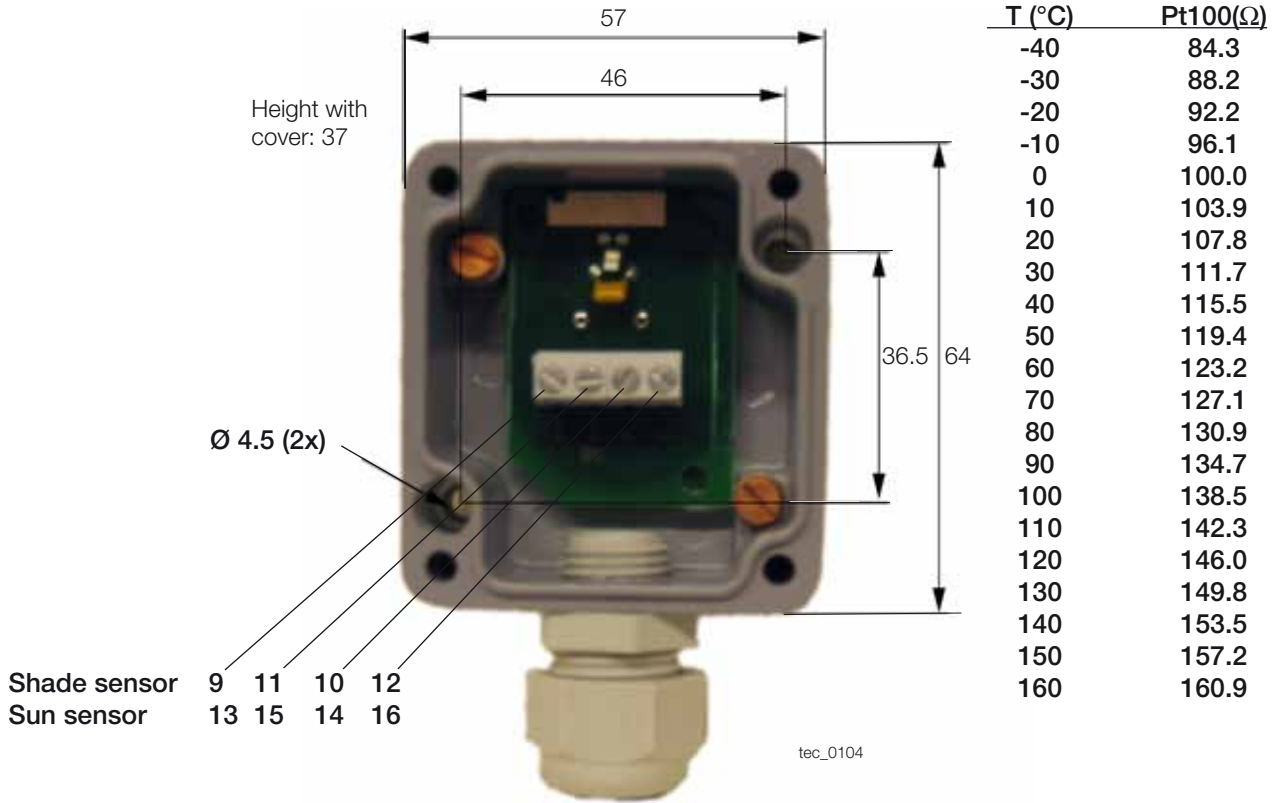

5.1.2 Oil temperature

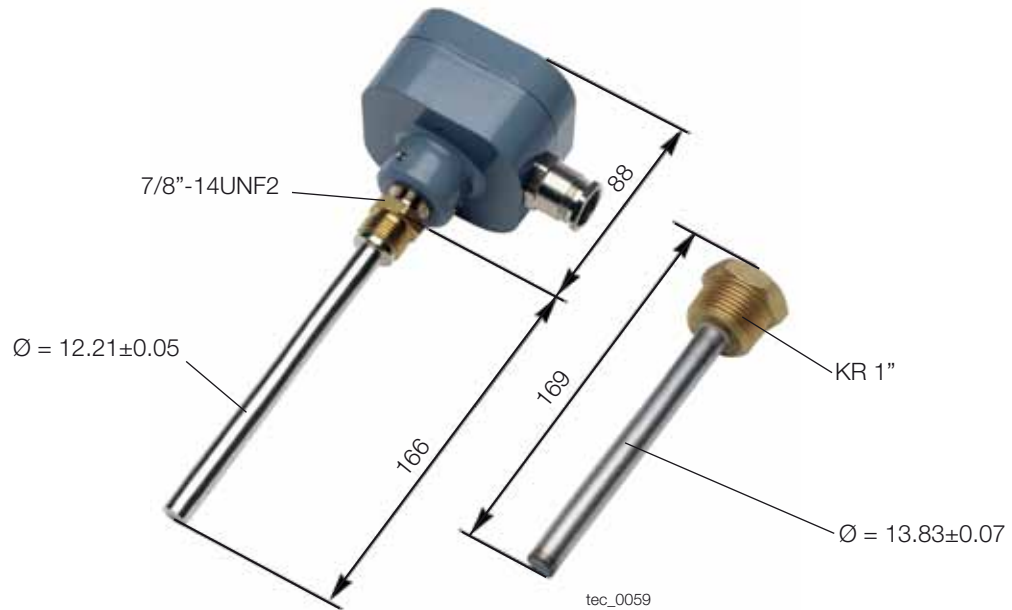

Pt100 sensor for oil temperatures at the top and bottom of the transformer and in the tap-changer. The thermometer pocket is included with the temperature sensor. Order a sensor for the tap-changer together with the tap-changer. Recommendations for bottom oil thermometer placement:

- The bottom oil sensor must be assembled at a position where the reading represents the temperature of the oil entering the windings.
- Should be placed level with the lower spacer ring (to avoid the cooler non-moving bottom oil).
- Should not be placed around 0.5 - 1 m from the cooler/radiator outlet (to measure in moving oil).

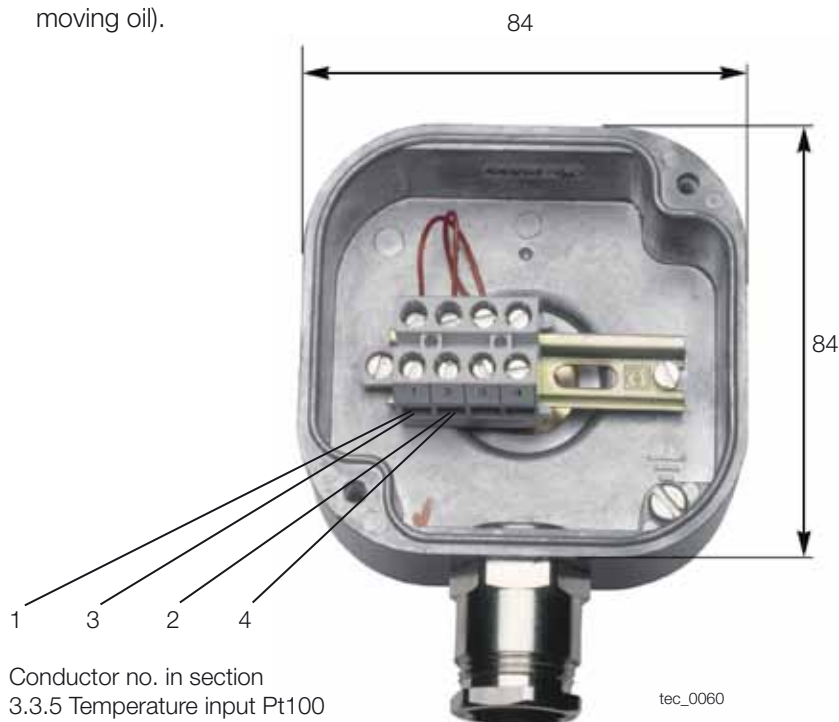

5.1.3 Current transducer

The current transducer is a 4-20 mA sensor connected to the cable from the transformer CT (Current Transformer). The sensor requires a 24 V DC supply to be connected in series with the signal. The 24 V DC power supply from X3:1 and X3:2 should be used. The cable from the CT should occasionally pass through the current transducer more than once. The number of turns can be found on the order data sheet. The current transducer can be calibrated from the interface. For more information, see the *Maintenance Guide*. If only one current transducer is used, the two current transducers should be placed on the same CT for backup purposes.

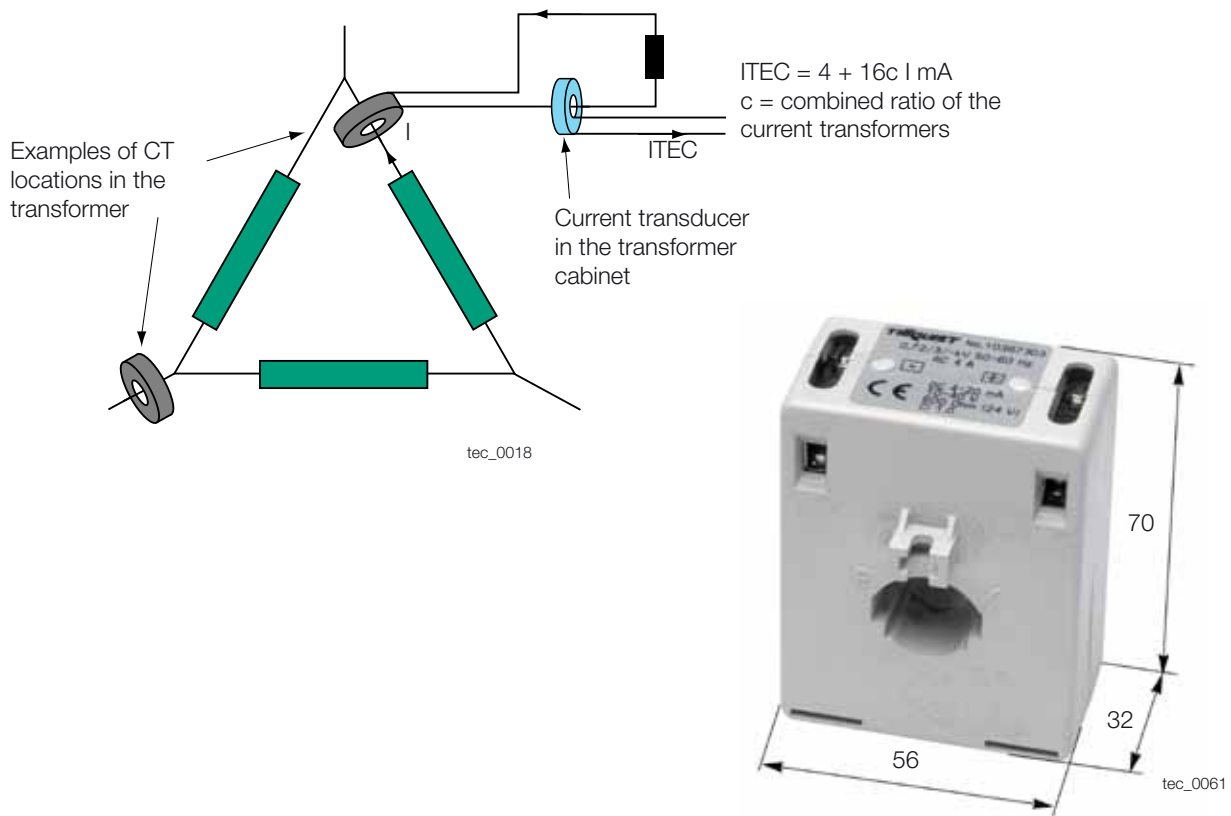

5.1.4 Hydrogen gas in oil

HYDRAN[®] is a suitable sensor for hydrogen gas. Other sensors providing a 4-20 mA signal can also be used. The General Electric HYDRAN[®] S2 can also be connected to the TEC via CAN bus.

For more information, contact your local ABB representative.

4.1.5 Moisture in oil sensor

A moisture in oil sensor providing an output of 4-20 mA can be used. The output can be ppm, water activity, or % RH. If the output is in ppm, the temperature output (4-20 mA) from the sensor does not need to be connected to the TEC.

5.2 Cables and earthing

Fiber-optic cable and cables to the sensors are normally included in the TEC delivery with lengths as specified in the *Ordering data guide*. All cable shields must be connected to the TEC cabinet earth in one of the following ways:

- With a Roxtec sealing system at the entrance of the cabinet
- With an EMC cable gland at the entrance of the cabinet
- At the common earth bar in the cabinet. The length of the strand from the cable/shield to the earth bar must not exceed 50 mm.

The sensor cable shields shall be connected to earth at one point only and therefore not connected to earth at the sensors.

5.2.1 Pt100

A shielded cable with four conductors in twisted pairs. One pair to feed current and one pair to measure resistance/voltage drop. Recommended conductor area 0.5 mm² (max 1.5).

5.2.2 Digital in

A shielded cable. Recommended conductor area 0.75 mm² (max 2.5).

5.2.3 4 – 20 mA

A shielded twisted pair cable. Conductor area between 0.5 and 2.5 mm².

5.2.4 RS 485 and data communication

A shielded cable with two conductors in twisted pair. Recommended conductor area 0.5 mm². Used for motor and alarm box.

5.2.5 CAN communication

For CAN communication, use shielded twisted pair cable, impedance 120 Ω.

To prevent signal disturbances on the CAN bus, one resistor with the same impedance as the cable is needed at the end of the CAN bus. If it is a long CAN bus, one resistor at each end is recommended. This is normally achieved by connecting a 120 Ω resistor between X11:1 and X11:2 in the TEC and one 120 Ω resistor between the same cables on the CAN sensor.

The node number or node ID on the CAN sensor for Hydrogen detection should be 110.

5.2.6 Cable entry and Rextec

Cables enter the cabinet at the bottom via a flange that is drilled and provided with cable glands at the transformer assembly, or via a Rextec sealing system.

Dimensions are given in section 3.1.1 Cabinet. Use the original manual for guidance in installation work.

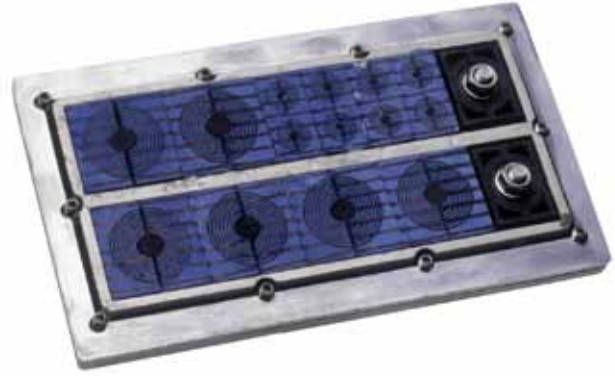

tec_0072

5.3 Time synchronization

The TEC unit has an internal clock for time stamping of events and data. The clock is synchronized during factory testing. The TEC has backup power for the clock for about one month.

The TEC unit can be connected to a synchronizing functionality, NTP server (see the *Maintenance Guide*) and/or second/minute pulse (TC 190).

6. TEC Server

The TEC Server is an extension to the TEC system.

It increases the functionality of the TEC system in three important areas:

- Extended data storage
- Single interface to the transformer together with protocol converter
- Portal for multiple TEC units.

Other functions are:

- Improved user interface
- Improved overload prediction
- Documentation and video capabilities
- Online service log functionality
- Prognosis intelligence.

The TEC Server is the common interface to each transformer connected to the computer, both for the personnel and for the control system. The information from the TEC systems and connected third party specialized sensors are stored in a database on the TEC Server and can easily be viewed and analyzed in the TEC Server web interface. The web interface can be viewed from any PC connected to the same network as the TEC Server.

The extended data storage makes it possible to follow the transformer service conditions during its whole lifetime and with higher sampling frequency compared to the TEC. Dangerous trends and other problematic developments are more easily monitored and prevented.

The information streamed from the TEC units to the TEC Server can be converted and distributed to other systems, for example SCADA, directly in data format. The TEC Server can be used as the single interface to the transformer. All transformer data and important evaluations are presented from a single system.

For more information, see the *TEC Server – User's Manual*.

Contact us

ABB AB

Components

SE-771 80 Ludvika, Sweden

Phone: +46 240 78 20 00

Fax: +46 240 121 57

E-Mail: sales@se.abb.com

www.abb.com/electricalcomponents