

ABB Components' Newsletter

Information to ABB Components' customers

September 1999

New UCG design

As announced earlier in the Newsletter of April '99, we have made some design changes to the UCG tap-changer. For orders with delivery from 1/1 2000, the new version of UCG will be delivered, except where otherwise stated in the order. The old version can still be delivered for a limited time, up to June 2000.

A number of changes have been made to make it possible to shorten the delivery time. The main differences from the old version are:

- The cylinder is fastened with rivets instead of with glue.
- New flange dimensions. New diameter is **740 mm**, was *725 mm*.
- New hole circle **710 mm**, was *690 mm*.
- The number of holes are **24**, was *22*.
- New cylinder diameter **470 mm**, was *420 mm*.
- New hole dimension in transformer. New diameter is **650 mm**, was min. *635 mm*.
- The bevel gear angle can be adjusted between 0° and 180°.
- The top section is painted grey-blue as standard.
- The positioning of the accessories.

The new dimensions are shown below in bold writing, the old dimensions are shown in italic in brackets.

The new drawings and 3D models are available at ABB Components' web site www.abb.se/com in the COM_MUNICATOR database.



ABB Components' Newsletter

Publisher: Peder Barmé
peder.barme@se.abb.com

Editor: Catharina Malmberg
catharina.malmberg@se.abb.com

Address: ABB Components
SE-771 80 Ludvika
Sweden

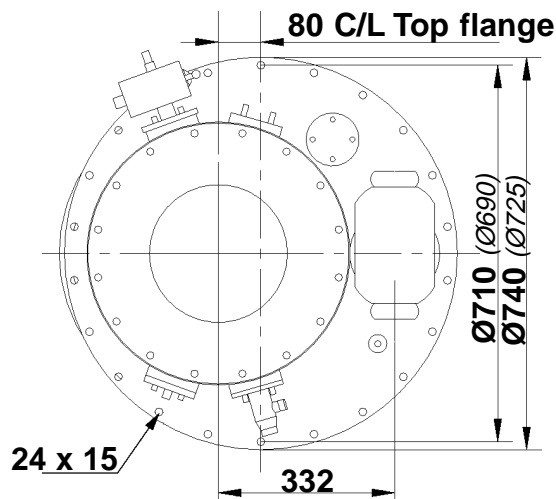
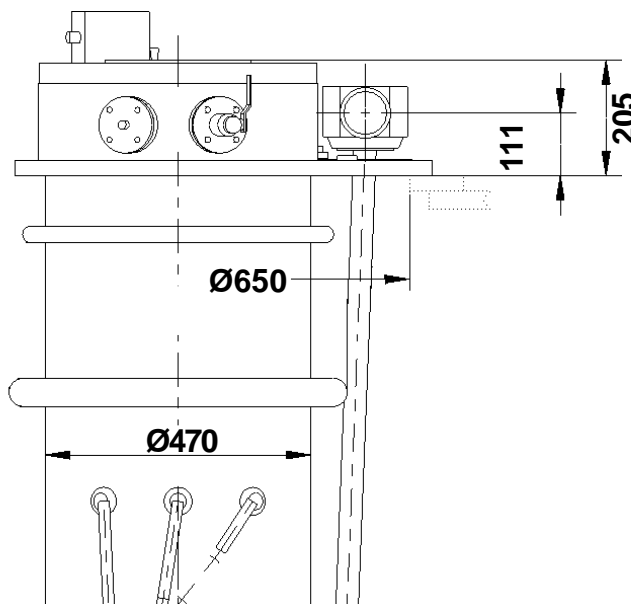
Fax No.: +46 240 121 57

E-mail:
sales@se.abb.com

Web site:
<http://www.abb.se/com/>

