



1ZSE 2750-102 en, Rev. 8

Transformer bushings, type GOB

Technical guide

This Technical Guide has been produced to allow transformer manufacturers, and their designers and engineers, access to all the technical information required to assist them in their selection of the appropriate transformer bushing.

The technical information pertaining to bushings manufactured by ABB has been divided into separate documents, with one document for each type.

The information provided in this document is intended to be general and does not cover all possible applications. Any specific application not covered should be referred directly to ABB, or its authorized representative.

ABB makes no warranty or representation and assumes no liability for the accuracy of the information in this document or for the use of such information. All information in this document is subject to change without notice.

Content

Design	4
Features and benefits.....	4
Shed profile, GOB 52 - 170 kV	5
Shed profile, GOB 300 kV.....	5
Common specifications.....	5
Testing.....	6
Test tap.....	6
Test tap adapter.....	6
Electrical data	7
Conductor loading	8
Overloading of bushings	8
Short-time current.....	8
Dimensions.....	9
Bushings without oil level gauge.....	11
Bushings with oil level gauge.....	13
Ordering particulars	14
Bushings without oil level gauge.....	14
Bushings with oil level gauge.....	16
Connection details	18
Inner terminal	18
Solid rod conductor	18
Outer terminal	19
Separate terminal plate with bolts	19
Arcing horns	19
Type GOB 1050.....	20
Dimensions.....	20
Ordering particulars	21
Recommendations for positioning.....	22

Design

The bushing is built up around a centre tube on which the condenser body is wound. The upper insulator, lower insulator and mounting flange are held between the end plates by the centre tube. Sealing is accomplished by oil-resistant rubber gaskets in grooves.

The annular space between the condenser body and the porcelain is filled with transformer oil. A gas-filled expansion space is left at the top. For GOB bushings without oil level gauge the oil level can be checked by means of a dipstick in the oil filling hole.

The lower end is shielded by an epoxy resin insulated aluminium shield. The shield is integrated for 52–170 kV, and separate for 300 kV bushings.

The inner terminal is attached to the centre tube by means of a through-going resilient pin which becomes locked when the outer terminal is screwed on. This design, patented by ABB, ensures effective electrical contact between the inner and outer terminals. The inner terminal can be chosen for connection to leads either by brazing or crimping.

The outer terminal is available in aluminium or copper alloy and can be supplemented by terminal plates of corresponding material.

The upper insulator is made in one piece of high quality electrical porcelain. The mounting flange is manufactured of corrosion-resistant aluminium alloy.

The mounting flange, the top housing and the top washer are protected by painting with a two-component primer and a grey-blue finishing coat of paint. The standard colour is Munsell 5.5B 55/1.25.

The bushings are delivered oil-filled and ready for use.

If the bushing is mounted with an inclination of more than 45° from the vertical, special measures have to be taken to ensure the condenser body is fully immersed in oil. Further information can be obtained on request.

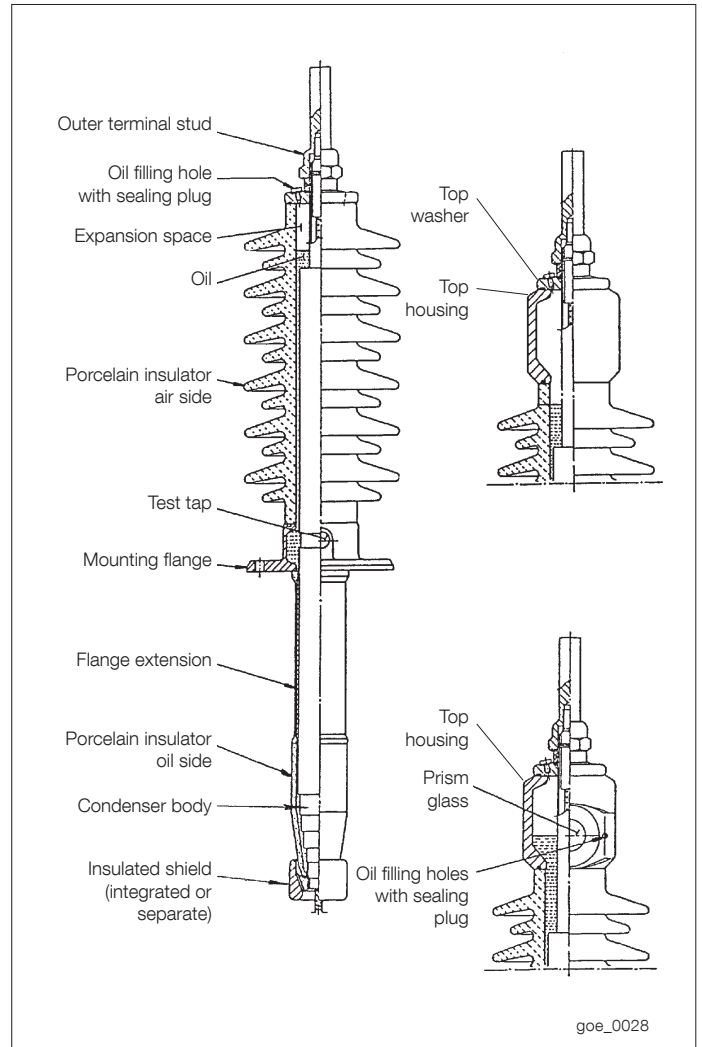

Fig. 1. Transformer bushing type GOB.

Features and benefits

- A complete range and outstanding operational experience from the most demanding applications for more than 30 years.
- 3D models makes it easy to incorporate the bushing in its context.
- We use a sealing system proven since 40 years around the world.
- Our test criteria and margins exceeding international standards.

Shed profile, GOB 52 - 170 kV

The shed profile is of the anti-fog type with alternating long and short sheds. For each pair of sheds the ratio between nominal creepage distance and the axial length is 3.43 and the ratio between protected and nominal creepage distance is 0.40.

According to IEC 60815 the creepage factor C.F. is <3.2 and the profile factor P.F. is >1.1 .

For special customer demands regarding creepage distance, other shed forms may be used.

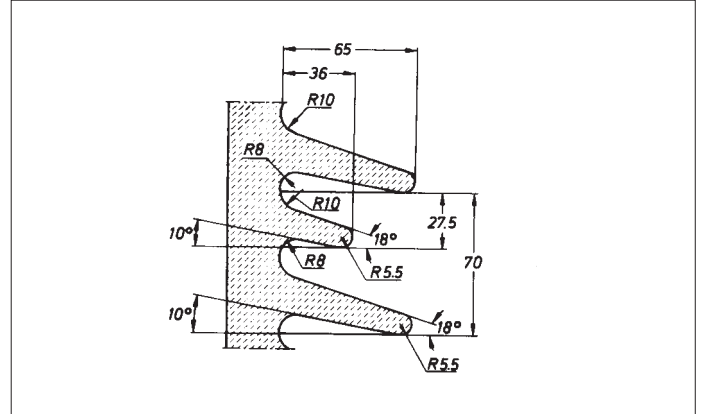

Fig. 2. Shed profile, GOB 52 – 170 kV.

Shed profile, GOB 300 kV

The shed form is of the anti-fog type with alternating long and short sheds. For each pair of sheds the ratio between nominal creepage distance and the axial length is 3.97 and the ratio between protected and nominal creepage distance is 0.4.

According to IEC 60815 the creepage factor C.F. is 3.7 and the profile factor P.F. is >1.1 .

For special customer demands regarding creepage distance, other shed forms may be used.

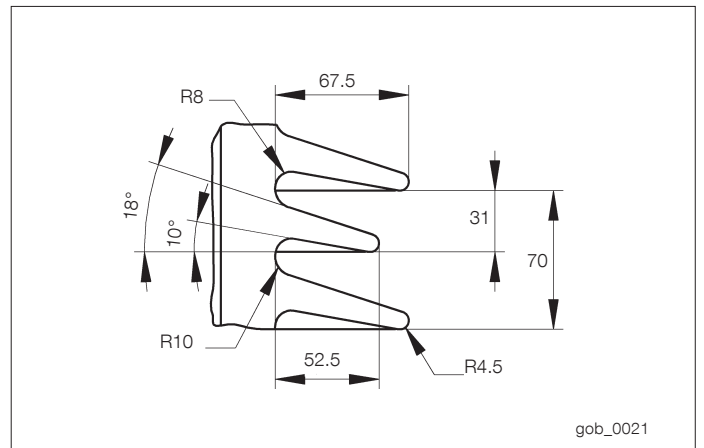

Fig. 3. Shed profile, GOB 300 kV.

Common specifications

Application:	Transformers
Classification:	Oil impregnated paper, capacitance graded, outdoor-immersed bushing
Ambient temperature:	+40 to -40 °C, minimum value as per temperature class 2 of IEC 60137 (-60 °C according to GOST 10693-81 item 2.26; Please contact ABB)
Altitude of site:	< 1 000 m
Level of rain and humidity:	1-2 mm rain/min horizontally and vertically, as per IEC 60060-1
Pollution level:	According to specified creepage distance and IEC 60815 ("Guide for selection of insulators with respect to polluted conditions")
Type of immersion medium:	Transformer oil. Maximum daily mean oil temperature 90 °C. Maximum temporary oil temperature 115 °C
Oil level below bushing flange:	Maximum 30 mm
Max. pressure of medium:	100 kPa overpressure
Markings:	Conforming to IEC/ IEEE

Testing

During the manufacture and on its completion the bushing is subjected to a number of routine tests, in compliance with IEC 60137. A tightness test is carried out on the assembled bushing after the final drying and impregnation. The test is made with an oil overpressure of 180 kPa (1.8 bar) for 12 hours at ambient temperature. No sign of leakage is allowed.

Each bushing is subjected to a final electrical routine test. The test is made at room temperature with the bushing submerged in oil. Capacitance and $\tan \delta$ are measured in steps up to the power frequency withstand voltage, which is maintained for one minute. Capacitance and $\tan \delta$ are also measured at decreasing voltage at the same voltage levels as before the one minute test.

Measurements for detection of internal partial discharge (PD measurements) are also made. These measurements are carried out at the same time as the power frequency withstand test. PD measurements are made in steps up to the full test voltage and down. It is always demonstrated that the PD value is max. 5 pC at test voltage equal to the rated system voltage.

GOB 1050 is also routine tested with a dry lightning impulse voltage withstand test.

Type tests have been carried out according to IEC 60137 and IEEE. Type test reports are available on request.

Test tap

The outer conducting layer of the condenser body is connected to an insulated test tap on the flange. During operation the test tap cover must be screwed on, in order to earth the bushing. The max. test voltage of the tap is 2 kV, 50 Hz for 1 minute. Max. service voltage is 600 V.

Test tap adapter

For permanent connection of the test tap to measuring circuits, a test tap adapter is required. Catalogue number 1ZSC003881-AAC.

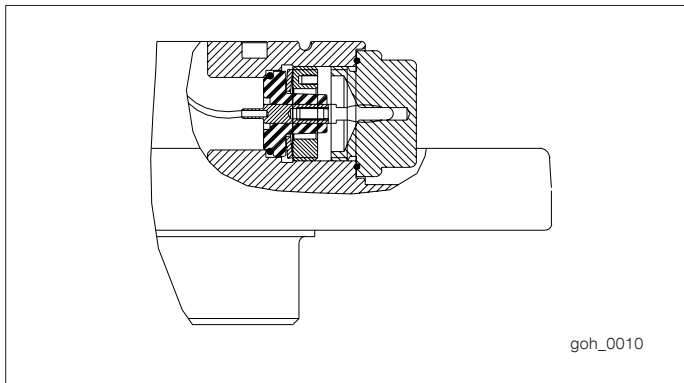

Fig. 4. Test tap

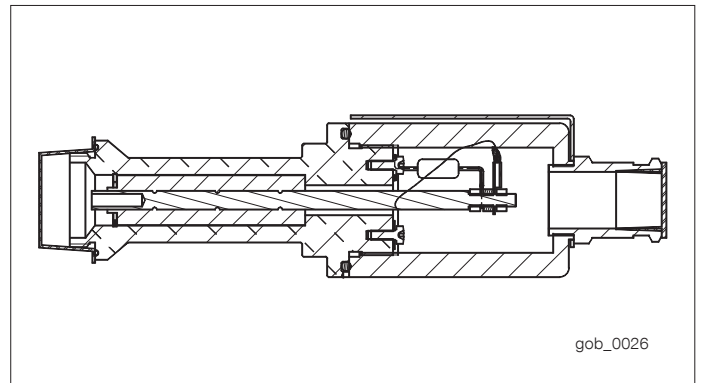

Fig. 5. Test tap adapter.

Electrical data

Type GOB	Rating				Routine test	Design data	
	Highest voltage for equipment U_m kV, RMS	Phase-to-earth voltage U_y kV, RMS	Dry lightning impulse kV, peak	Wet power frequency AC kV, RMS	1 min. dry 50 Hz kV, RMS	Dry switching impulse kV, peak	Wet switching impulse kV, peak
250-800	52	52	250	105	120	230	-
250-1250	52	52	250	105	120	230	-
325-800	72.5	72.5	350	140	160	300	-
380-800	100	72.5	380	150	165	330	-
380-1250	100	72.5	380	150	165	330	-
450-800	123	90	450	185	195	410	-
550-800	170	123	550	230	260	470	-
550-1250	170	123	550	230	260	470	-
650-1250	170	145	650	275	300	580	-
750-1250	170	170	750	325	365	670	-
1050-1100	300	173	1050	510	510	810	750

Conductor loading

The rated currents listed in this catalogue are the standardised values according to IEC 60137 which, with the largest possible conductor, fulfil the temperature rise test.

The GOB bushings fulfil the temperature rise test requirements according to IEC 60137 and IEEE C57.19.00-1991.

Rated current A	Conductor	52 – 170 kV		300 kV	
		Permissible current		Permissible current	
		IEC, A	IEEE, A	IEC, A	IEEE, A
800	Solid rod LF 170 019	800	730		
1100, 1250	Solid rod LF 170 052	1250	1200	1100	1000
800, 1100, 1250	Stranded cable 50 mm ²	165	150	155	130
800, 1100, 1250	Stranded cable 70 mm ²	225	210	190	160
800, 1100, 1250	Stranded cable 95 mm ²	300	285	240	195
800, 1100, 1250	Stranded cable 150 mm ²	475	415	330	275
1100, 1250	Stranded cable 185 mm ²	530	460	380	320
1100, 1250	Stranded cable 285 mm ²	665	570	540	450

Overloading of bushings

If the conductor for the bushing is selected with 120 % of the rated current of the transformer, the bushing is considered to be able to withstand the overload conditions stated in IEC 60354 without further clarifications or tests, according to IEC 60137.

Short-time current

The rated thermal short-time current (I_{th}) is calculated according to IEC 60137.

For draw-lead of stranded copper, values are given for 100 mm². For other areas the short-time current is directly proportional to the area.

Conductor	Rated current A	Area mm ²	Short-time current (I_{th})		Dynamic current (I_d) kA, peak
			1 s kA, RMS	2 s kA, RMS	
Solid rod	800	-	30	21	52
Solid rod	1100/1250	-	70	50	125
Stranded draw-lead	365	100	9.6	6.8	17

Dimensions

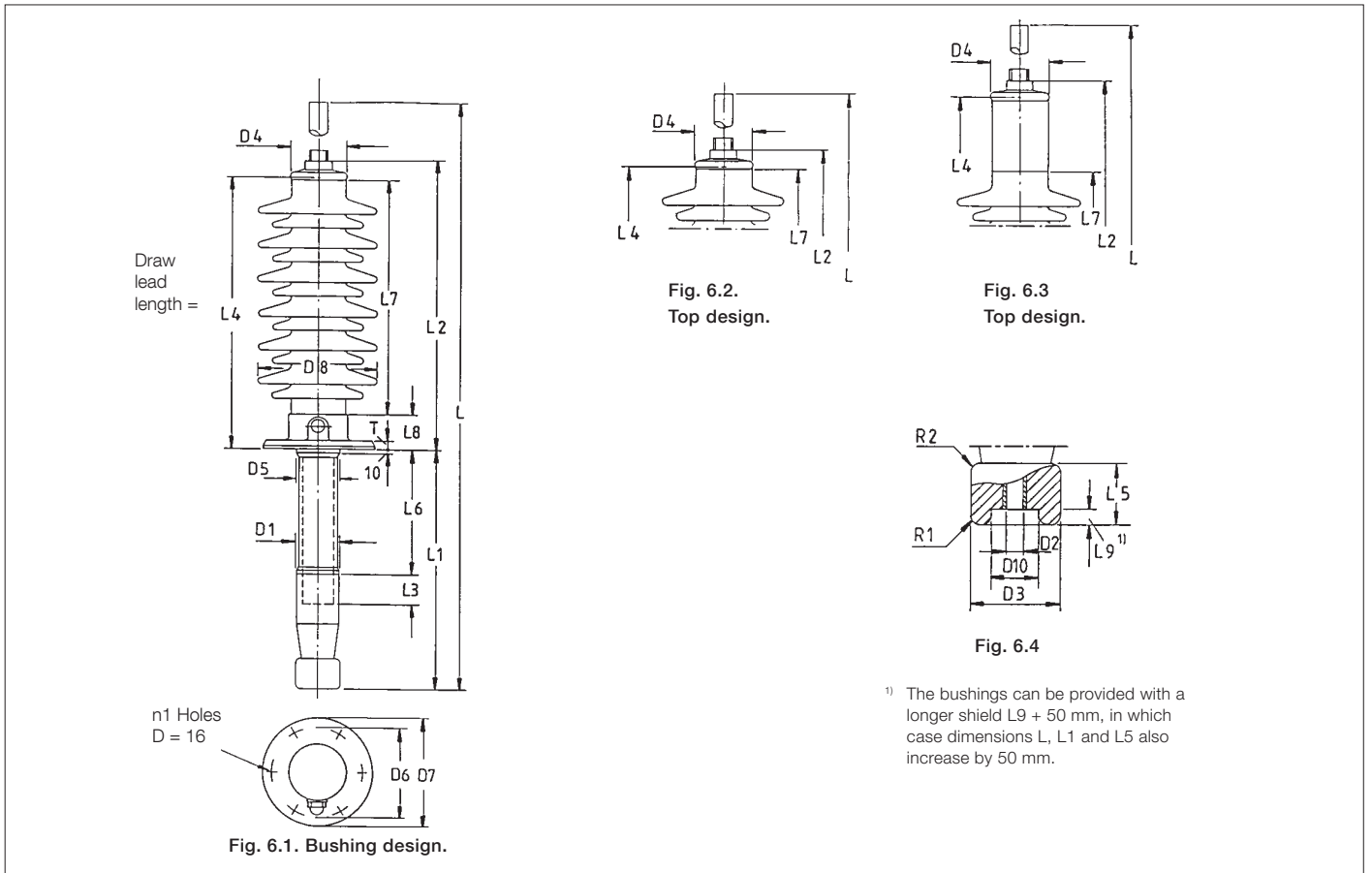

Fig. 6.1 - 6.4. GOB without oil level gauge, dimensions.

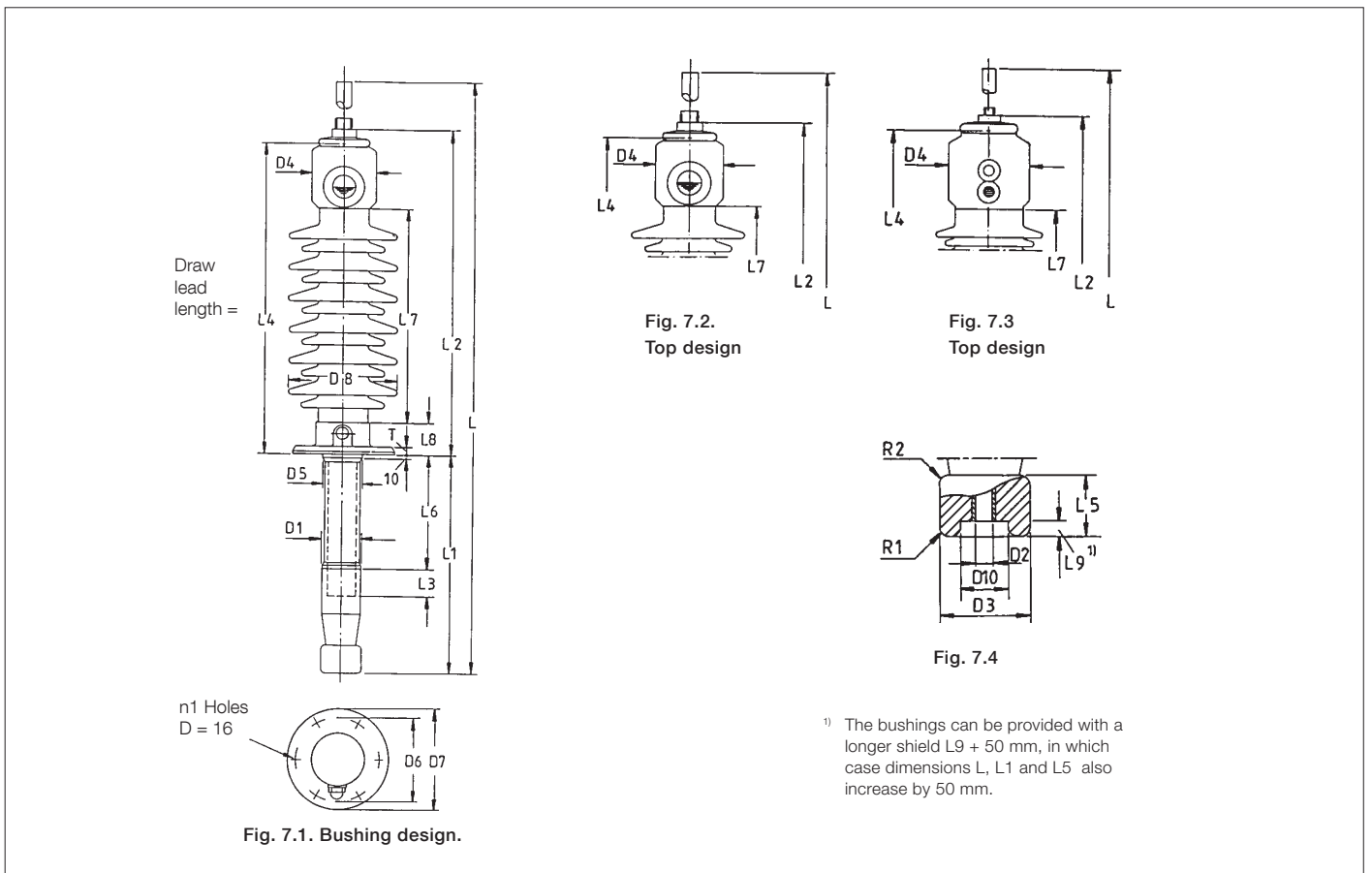

Fig. 7.1 - 7.4. GOB with oil level gauge, dimensions.

Bushings without oil level gauge

Dimensions are subject to modification without notice.

Type GOB	Rated current A	Cat. No.	Space for current transformer mm	Net mass kg	Top design acc. to Fig.	Dimensions in mm											
						L ¹⁾	L1 ¹⁾	L2	L3	L4	L5 ¹⁾	L6	L7	L8	L9 ¹⁾		
250	800	LF 123	013-	-	23	6.2	998	240	590	65	555	60	-	480	70	15	
			015-	300	25	6.2	1258	500	590		555		260				
			083-	500	27	6.3	1558	700	690		655		460				
250	1250	LF 123	017-	-	26	6.2	1063	255	605	65	580	75	-	480	70	25	
			019-	300	29	6.2	1323	515	605		580		260				
			085-	500	31	6.3	1623	715	705		680		460				
325	800	LF 123	025-	-	27	6.2	1198	295	735	93	700	60	-	625	70	15	
			027-	300	31	6.2	1458	555	735		700		260				
			089-	500	35	6.3	1758	755	835		800		460				
380	800	LF 123	037-	-	33	6.2	1303	345	790	98	755	60	-	680	70	15	
			039-	300	37	6.2	1543	585	790		755		240				
			095-	500	39	6.3	1843	785	890		855		440				
380	1250	LF 123	041-	-	37	6.2	1368	360	805	98	780	75	-	680	70	25	
			043-	300	39	6.2	1608	600	805		780		240				
			097-	500	43	6.3	1908	800	905		880		440				
450	800	LF 123	049-	-	42	6.2	1473	345	960	98	925	60	-	850	70	15	
			051-	300	45	6.2	1713	585	960		925		240				
			053-	500	48	6.3	2013	785	1060		1025		440				
550	800	LF 123	061-	100	70	6.2	1823	495	1160	60	1125	90	95	1050	60	25	
			063-	300	73	6.2	2108	680	1260		1225		280				
			107-	500	77	6.3	2308	880	1260		1225		480				
550	1250	LF 123	065-	100	105	6.2	1868	495	1170	68	1145	100	95	1050	60	30	
			067-	300	109	6.2	2153	680	1270		1245		280				
			109-	500	115	6.3	2353	880	1270		1245		480				
650	1250	LF 123	073-	150	116	6.2	2153	580	1370	60	1345	100	120	1250	60	30	
			075-	300	122	6.2	2413	740	1470		1445		280				
			113-	500	126	6.3	2613	940	1470		1445		480				
750	1250	LF 123	077-	200	180	6.2	2468	685	1580	70	1555	100	165	1460	60	30	
			078-	300	190	6.2	2683	800	1680		1655		280				
			079-	500	200	6.3	2883	1000	1680		1655		480				

D1	D2	D3	D4	D5	D6	D7	D8	D10	n1	R1	R2	T	Creepage distance mm	Cantilever load Max. permitted loading perpendicular to the terminal N	60 s Test N
86	22	86	115	88	185	225	230	46	6	8	6	16	1690±50	1800	2340
101	34	112	120	101	250	290	245	70	8	12	10	16	1500±50	3000	4000
95	22	86	115	96	185	225	230	46	6	8	6	16	2240±50	1500	1950
95	22	86	115	96	185	225	240	46	6	8	6	16	2210±70	1400	1800
112	34	112	120	112	250	290	245	70	8	12	10	16	2500±70	2900	3750
95	22	86	115	96	185	225	245	46	6	8	6	16	2720±80	1150	1500
126	22	118	145	150	250	290	280	50	8	12	12	18	3890±100	1300	1700
160	34	140	175	200	290	335	300	70	12	15	15	20	3430±100	2400	3100
160	34	140	175	200	290	335	305	70	12	15	15	20	4600±110	2600	3380
184	34	140	230	184	290	335	350	70	12	15	15	20	5420±150	2600	3350

Bushings with oil level gauge

Dimensions are subject to modification without notice.

Type GOB	Rated current A	Cat. No.		Space for current transformer mm	Net mass kg	Top design acc. to Fig.	Dimensions in mm										
							L ¹⁾	L1 ¹⁾	L2	L3	L4	L5 ¹⁾	L6	L7	L8	L9 ¹⁾	
250	800	LF 123	171-	-	24	7.2	1138	240	730	65	695	60	-	480	70	15	
			173-	300	26		1398	500					260				
			175-	500	28		1598	700					460				
250	1250	LF 123	167-	-	28	7.2	1203	255	745	65	720	75	-	480	70	25	
			168-	300	30		1463	515					260				
			169-	500	33		1663	715					460				
325	800	LF 123	177-	-	28	7.2	1338	295	875	93	840	60	-	625	70	15	
			179-	300	32		1598	555					260				
			181-	500	36		1798	755					460				
380	800	LF 123	183-	-	34	7.2	1443	345	930	98	895	60	-	680	70	15	
			185-	300	38		1683	585					240				
			187-	500	40		1883	785					440				
380	1250	LF 123	101-	-	38	7.2	1508	360	945	98	920	75	-	680	70	25	
			102-	300	41		1748	600					240				
			103-	500	44		1948	800					440				
450	800	LF 123	145-	-	43	7.2	1613	345	1100	98	1065	60	-	850	70	15	
			147-	300	46		1853	585					240				
			149-	500	49		2053	785					440				
550	800	LF 123	189-	100	71	7.2	1963	495	1300	60	1265	90	95	1050	60	25	
			190-	300	74		2148	680					280				
			191-	500	78		2348	880					480				
550	1250	LF 123	142-	100	106	7.2	2008	495	1310	68	1285	100	95	1050	60	30	
			143-	300	110		2193	680					280				
			144-	500	116		2393	880					480				
650	1250	LF 123	192-	150	118	7.2	2293	580	1510	60	1485	100	120	1250	60	30	
			193-	300	124		2453	740					280				
			194-	500	128		2653	940					480				
750	1250	LF 123	104-	200	187	7.3	2718	685	1830	70	1805	100	165	1460	60	30	
			105-	300	197		2833	800					280				
			106-	500	207		3033	1000					480				

D1	D2	D3	D4	D5	D6	D7	D8	D10	n1	R1	R2	T	Creepage distance mm	Cantilever load Max. permitted loading perpendicular to the terminal N	60 s Test N
86	22	86	140	88	185	225	230	46	6	8	6	16	1690±50	1800	2340
101	34	112	140	101	250	290	245	70	8	12	10	16	1500±50	3000	4000
95	22	86	140	96	185	225	230	46	6	8	6	16	2240±50	1500	1950
95	22	86	140	96	185	225	240	46	6	8	6	16	2210±70	1400	1800
112	34	112	140	112	250	290	245	70	8	12	10	16	2500±70	2900	3750
95	22	86	140	96	185	225	245	46	6	8	6	16	2720±80	1150	1500
126	22	118	200	150	250	290	280	50	8	12	12	18	3890±100	1300	1700
160	34	140	265	200	290	335	300	70	12	15	15	20	3430±100	2400	3100
160	34	140	265	200	290	335	305	70	12	15	15	20	4000±110	2600	3380
184	34	140	265	184	290	335	350	70	12	15	15	20	5420±150	2600	3350

Ordering particulars

Bushings without oil level gauge

When ordering, please state:

- Type and catalogue number for bushings.
- Catalogue number for inner and outer terminal assembly.
- Additional accessories or modifications.
- Test required, in addition to the normal routine tests.
- Test tap adapter, if required.

Note:

The catalogue number should have one of the following letters added to it, to indicate the type of insulator and oil end shield:

- K Normal oil end shield, brown porcelain
- L Normal oil end shield, light grey porcelain
- M Longer oil end shield, brown porcelain
- N Longer oil end shield, light grey porcelain

Bushings					Connection details, Cat. No. LF 170						
Type GOB	Rated current A	Cat. No.	Space for current transformer mm	Bushings tube (See Fig. 6.4) D2, mm	Inner terminal stud						Undrilled with pilot hole
					For crimping or brazing			For brazing		Conductor area ≤285 mm ²	
					Conductor area			Conductor area			
50 mm ²	70 mm ²	95 mm ²	≤150 mm ²	≤285 mm ²							
250	800	LF 123	013-	-	22	010-M	010-N	010-L	011-S	-	011-U
			015-	300							
			083-	500							
250	1250	LF 123	017-	-	34	-	-	-	-	011-T	011-V
			019-	300							
			085-	500							
325	800	LF 123	025-	-	22	010-M	010-N	010-L	011-S	-	011-U
			027-	300							
			089-	500							
380	800	LF 123	037-	-	22	010-M	010-N	010-L	011-S	-	011-U
			039-	300							
			095-	500							
380	1250	LF 123	041-	-	34	-	-	-	-	011-T	011-V
			043-	300							
			097-	500							
450	800	LF 123	049-	-	22	010-M	010-N	010-L	011-S	-	011-U
			051-	300							
			053-	500							
550	800	LF 123	061-	100	22	010-M	010-N	010-L	011-S	-	011-U
			063-	300							
			107-	500							
550	1250	LF 123	065-	100	34	-	-	-	-	011-T	011-V
			067-	300							
			109-	500							
650	1250	LF 123	073-	150	34	-	-	-	-	011-T	011-V
			075-	300							
			113-	500							
750	1250	LF 123	077-	200	34	-	-	-	-	011-T	011-V
			078-	300							
			079-	500							

- HK Horizontal mounting, normal oil end shield, brown porcelain
- HL Horizontal mounting, normal oil end shield, light grey porcelain
- HM Horizontal mounting, longer oil end shield, brown porcelain
- HN Horizontal mounting, longer oil end shield, light grey porcelain

Outer terminal assembly				Solid rod conductor				Arcing horns		
Stud with O-ring and locking pin		Separate terminal plate with bolts		Alt. 1		Alt. 2		Mass kg		
Aluminium	Copper alloy	Aluminium	Nickel-plated copper							
001-A	002-A	014-A	021-A	019	-A	019	-	2.6	004	-A
					-D		-B	3.3		-A
					-E		-C	4.2		-B
001-B	002-B	014-A	021-A	052	-A	052	-	6.8	004	-A
					-D		-B	8.4		-A
					-E		-C	10.6		-B
001-A	002-A	014-A	021-A	019	-F	019	-	3.1	004	-A
					-K		-G	3.9		-A
					-L		-H	4.7		-B
001-A	002-A	014-A	021-A	019	-M	019	-	3.5	004	-A
					-R		-N	4.2		-A
					-S		-P	5.0		-B
001-B	002-B	014-A	021-A	052	-V	052	-	8.6	004	-B
					-Z		-X	10.4		-B
					-AA		-Y	12.7		-B
001-A	002-A	014-A	021-A	019	-BL	019	-	4.0	004	-B
					-BM		-BN	4.7		-B
					-BP		-BR	5.5		-C
001-A	002-A	014-A	021-A	019	-T	019	-	4.9	004	-B
					-X		-U	5.7		-C
					-Y		-V	6.3		-C
001-B	002-B	014-A	021-A	052	-AM	052	-	12.0	004	-B
					-AN		-AP	14.1		-C
					-AR		-AS	15.5		-C
001-B	002-B	014-A	021-A	052	-F	052	-	14.0	005	-A
					-K		-G	15.9		-B
					-L		-H	17.5		-B
001-B	002-B	014-A	021-A	052	-M	052	-	16.3	005	-B
					-R		-N	18.0		-E
					-S		-P	19.5		-E

Bushings with oil level gauge

When ordering, please state:

- Type and catalogue number for bushings.
- Catalogue number for inner and outer terminal assembly.
- Additional accessories or modifications.
- Test required, in addition to the normal routine tests.
- Test tap adapter, if required.

Note:

The catalogue number should have one of the following letters added to it, to indicate the type of insulator and oil end shield:

- K Normal oil end shield, brown porcelain
- L Normal oil end shield, light grey porcelain
- M Longer oil end shield, brown porcelain
- N Longer oil end shield, light grey porcelain

Bushings					Connection details, Cat. No. LF 170						
Type GOB	Rated current A	Cat. No.		Space for current transformer mm	Bushings tube (See Fig. 7.4) D2, mm	Inner terminal stud					Undrilled with pilot hole
						For crimping or brazing			For brazing		
						Conductor area			Conductor area		
50 mm ²	70 mm ²	95 mm ²	≤150 mm ²	≤285 mm ²							
250	800	LF 123	171-	-	22	010-M	010-N	010-L	011-S	-	011-U
			173-	300							
			175-	500							
250	1250	LF 123	167-	-	34	-	-	-	-	011-T	011-V
			168-	300							
			169-	500							
325	800	LF 123	177-	-	22	010-M	010-N	010-L	011-S	-	011-U
			179-	300							
			181-	500							
380	800	LF 123	183-	-	22	010-M	010-N	010-L	011-S	-	011-U
			185-	300							
			187-	500							
380	1250	LF 123	101-	-	34	-	-	-	-	011-T	011-V
			102-	300							
			103	500							
450	800	LF 123	145-	-	22	010-M	010-N	010-L	011-S	-	011-U
			147-	300							
			149-	500							
550	800	LF 123	189-	100	22	010-M	010-N	010-L	011-S	-	011-U
			190-	300							
			191-	500							
550	1250	LF 123	142-	100	34	-	-	-	-	011-T	011-V
			143-	300							
			144-	500							
650	1250	LF 123	192-	150	34	-	-	-	-	011-T	011-V
			193-	300							
			194-	500							
750	1250	LF 123	104-	200	34	-	-	-	-	011-T	011-V
			105-	300							
			106-	500							

- HK Horizontal mounting, normal oil end shield, brown porcelain
- HL Horizontal mounting, normal oil end shield, light grey porcelain
- HM Horizontal mounting, longer oil end shield, brown porcelain
- HN Horizontal mounting, longer oil end shield, light grey porcelain

Outer terminal assembly				Solid rod conductor				Arcing horns		
Stud with O-ring and locking pin		Separate terminal plate with bolts		Alt. 1		Alt. 2		Mass kg		
Aluminium	Copper alloy	Aluminium	Tin-plated copper							
001-A	002-A	014-A	021-A	019	-AM	019	-	3.0	004	-B
					-AS		-AT	3.7		-B
					-BB		-BC	4.3		-B
001-B	002-B	014-A	021-A	052	-BC	052	-	7.7	004	-B
					-BF		-BD	9.3		-B
					-BG		-BE	10.8		-B
001-A	002-A	014-A	021-A	019	-AN	019	-	3.5	004	-B
					-AU		-AV	4.3		-B
					-BD		-BE	4.8		-B
001-A	002-A	014-A	021-A	019	-AP	019	-	3.9	004	-B
					-AX		-AY	4.6		-B
					-BF		-BG	5.1		-B
001-B	002-B	014-A	021-A	052	-BK	052	-	9.6	004	-B
					-BN		-BL	11.4		-B
					-BP		-BM	12.6		-B
001-A	002-A	014-A	021-A	019	-BS	019	-	4.4	004	-C
					-BT		-BU	5.1		-C
					-BV		-BX	5.6		-C
001-A	002-A	014-A	021-A	019	-AR	019	-	5.3	004	-C
					-AZ		-BA	5.8		-C
					-BH		-BK	6.4		-C
001-B	002-B	014-A	021-A	052	-AT	052	-	13.0	004	-C
					-AU		-AX	14.4		-C
					-AV		-AY	15.8		-C
001-B	002-B	014-A	021-A	052	-AD	052	-	14.9	005	-B
					-AE		-AF	16.1		-B
					-AG		-AH	17.7		-B
001-B	002-B	014-A	021-A	052	-AZ	052	-	18.0	005	-F
					-BA		-BB	19.0		-F
					-AK		-AL	20.5		-F

Connection details

Inner terminal

Stud made of copper for connection of draw lead. The inner terminal must be provided with an outer terminal.

Material and design	Conductor area mm ²	Cat. No.	Dimensions mm			Mass kg	
			D1	D2	L		
Copper for crimping or brazing	50	LF 170 010	-M	11	14.5	35	0.3
	70		-N	13	17	35	0.3
	95		-L	15	20	35	0.3
Copper for brazing only	≤ 150	LF 170 011	-S	18	20	35	0.3
	undrilled		-U	5	20	35	0.3
	≤ 285		-T	29	32	20	0.6
	undrilled		-V	5	32	20	0.6

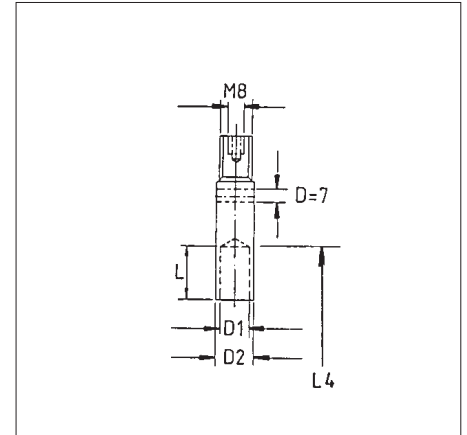

Fig. 8. Inner terminal.

Solid rod conductor

The rod is produced from electrolytic copper and is divided into two parts. For the 800 A conductor the two parts are held together by a centre bolt with a resilient locking pin. For the 1100/1250 A conductor the two parts are connected by counter-sunk screws.

The lower part of the solid rod is designed to enable connection by brazing.

The solid rod conductor can be divided either:

Alt. 1: 20 mm below the bushing flange, or

Alt. 2: 20 mm below the upper end of the bottom porcelain.

The solid rod conductor must be provided with an outer terminal.

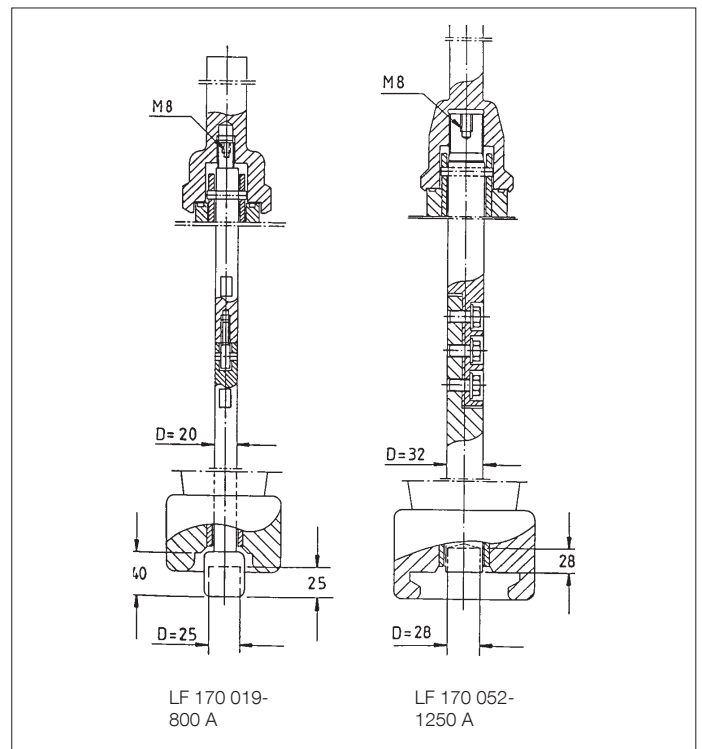

Fig. 9. Solid rod conductor.

Outer terminal

Stud made of copper alloy or aluminium with O-ring and locking pin. Other types can be provided on request.

Material	Cat. No.		Dimensions mm		Mass kg	For bushings with D2 mm
			D	N		
Aluminium	LF 170 001	-A	30	55	0.5	22
		-B	30	66	0.8	34
Copper alloy	LF 170 002	-A	30	55	1.2	22
		-B	30	66	2.3	34

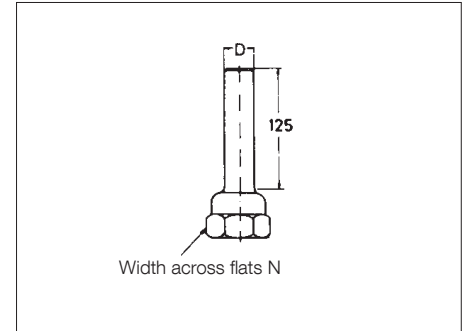

Fig. 10. Outer terminal assembly.

Separate terminal plate with bolts

The separate terminal plate is used for connecting the bushing to the line conductor.

Material	Cat. No.
Aluminium	LF 170 014-A
Nickel-plated copper	LF 170 021-A

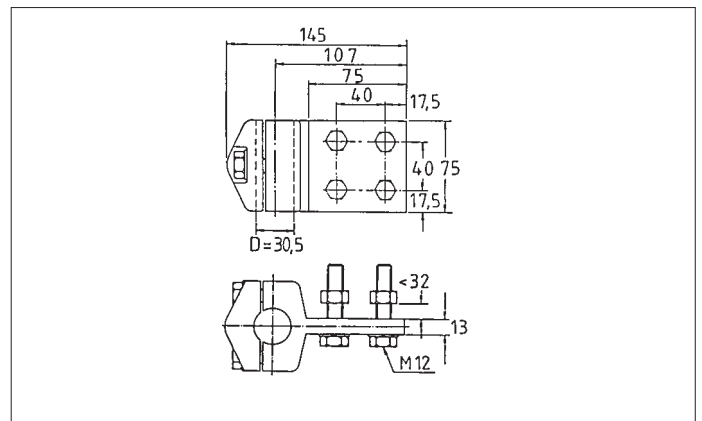

Fig. 11. Separate terminal plate with bolts.

Arcing horns

Arcing horns of galvanised steel can be mounted on the bushing.

The lower rod is fastened onto the flange with one of the fixing screws and the upper rod by means of a bracket on the outer terminal.

The gap distances for standard arcing horns are shown in the table. Other gap distances on request.

Type GOB	K mm	C mm	H mm
250	230–440	315	112
325	320–580	315	112
380	400–620	315	112
450	400–780	315	112
550	620–960	315	114
650	700–1080	380	224
750	820–1290	380	224
1050	950–1840	420	410

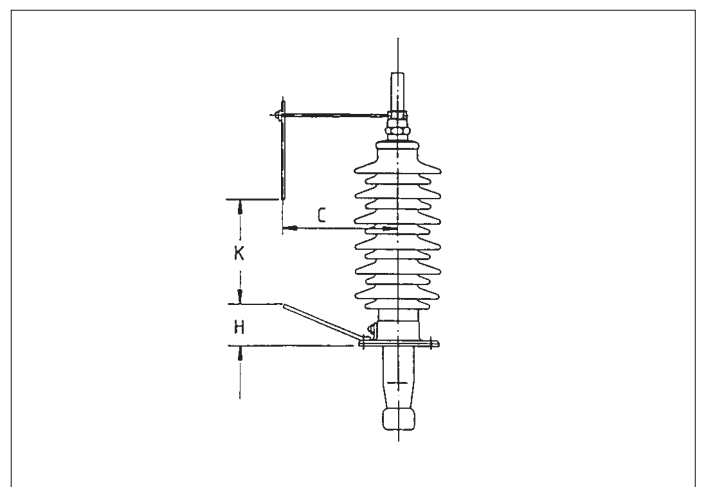

Fig. 12. Gap distances.

Type GOB 1050

Dimensions

When ordering, please state:

- Type and catalogue number for bushings.
- Catalogue number for inner and outer terminal assembly.
- Additional accessories or modifications.
- Test required, in addition to the normal routine tests.
- Test tap adapter, if required.

Note:

The catalogue number should have one of the following letters added to it, to indicate the type of insulator and oil end shield:

- K Brown porcelain
- L Light grey porcelain

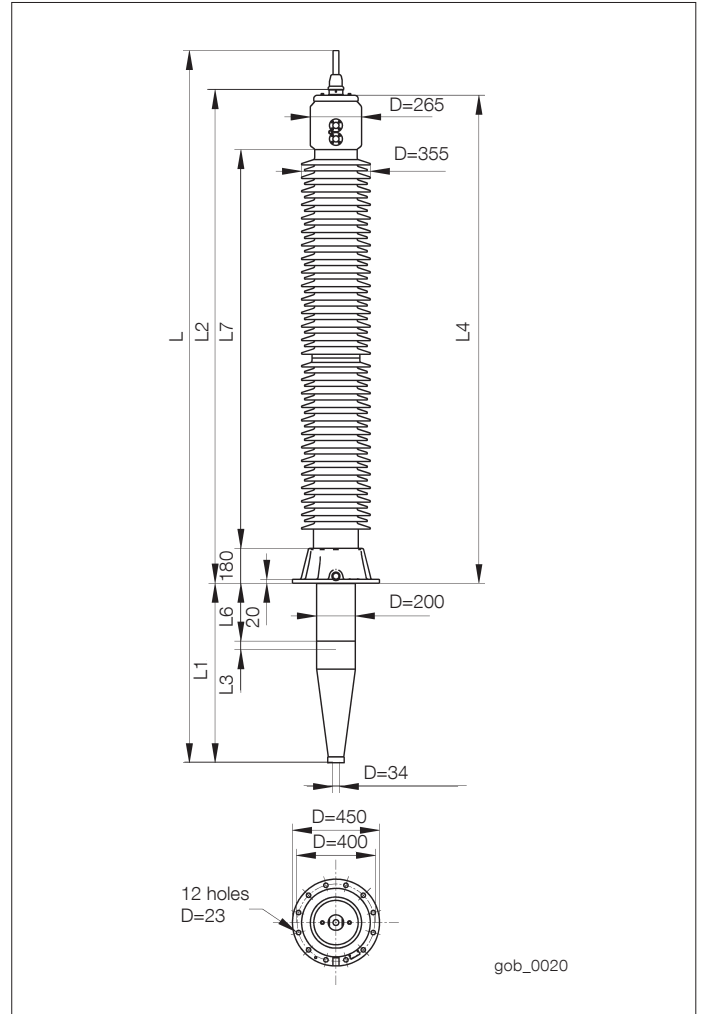

Fig. 13. Dimensions, GOB 1050.

Dimensions are subject to modification without notice.

Rated current A	Cat. No.	Space for current transformer mm	Net mass kg	Dimensions in mm							Creepage distance		Cantilever load	
				L	L1	L2	L3	L4	L6	L7	total mm	protected mm	Max N	Test N
1100	LF 123 281-	300	335	3690	930	2555	49	2530	300	2066	7500	3200	1250	3200
	LF 123 280-	600	350	3990	1230	2555	49	2530	600	2066	7500	3200	1250	3200

Ordering particulars

Connection details Cat. No. LF 170

Dimensions refer to the epoxy insulated shield. The thickness of the pressboard is 3 mm.

Cat. No.	Inner terminal stud				Solid rod conductor						Oil end shield		Arcing horns
	For brazing		Stud with O-ring and locking pin		Alt. 1	Alt. 2	Alt. 3	Epoxy insulated	Pressboard insulated				
	Conductor area <math><285\text{ mm}^2</math>	Undrilled with pilot hole	Aluminium	Copper alloy									
LF 123 281-	011-T	011-V	001-B	002-B	052	-FD	052	-FE	052	-FF	092-B	092-D	005-G
LF 123 280-						-FA		-FB		-FC			

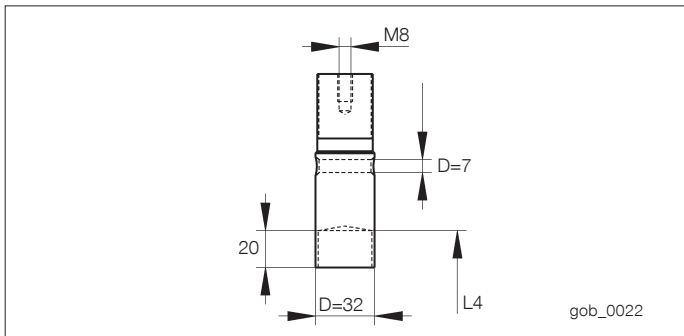

Fig. 14. Inner terminal.

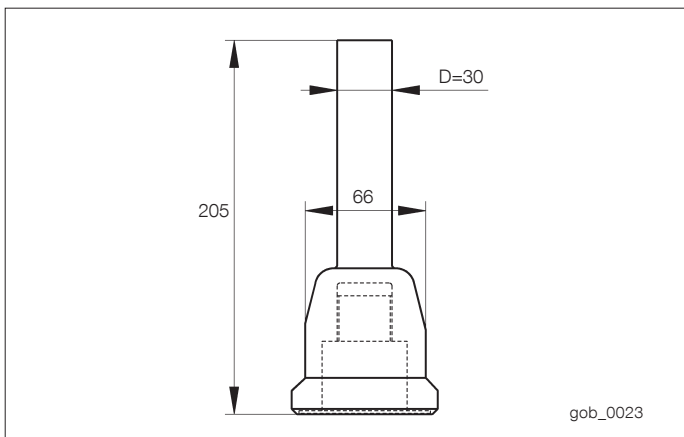

Fig. 15. Outer terminal.

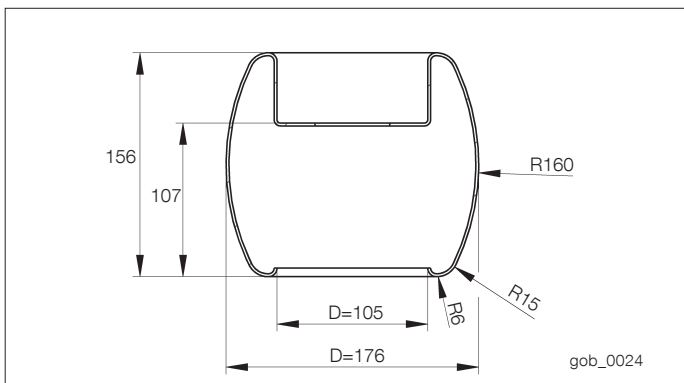

Fig. 16. Oil end shield.

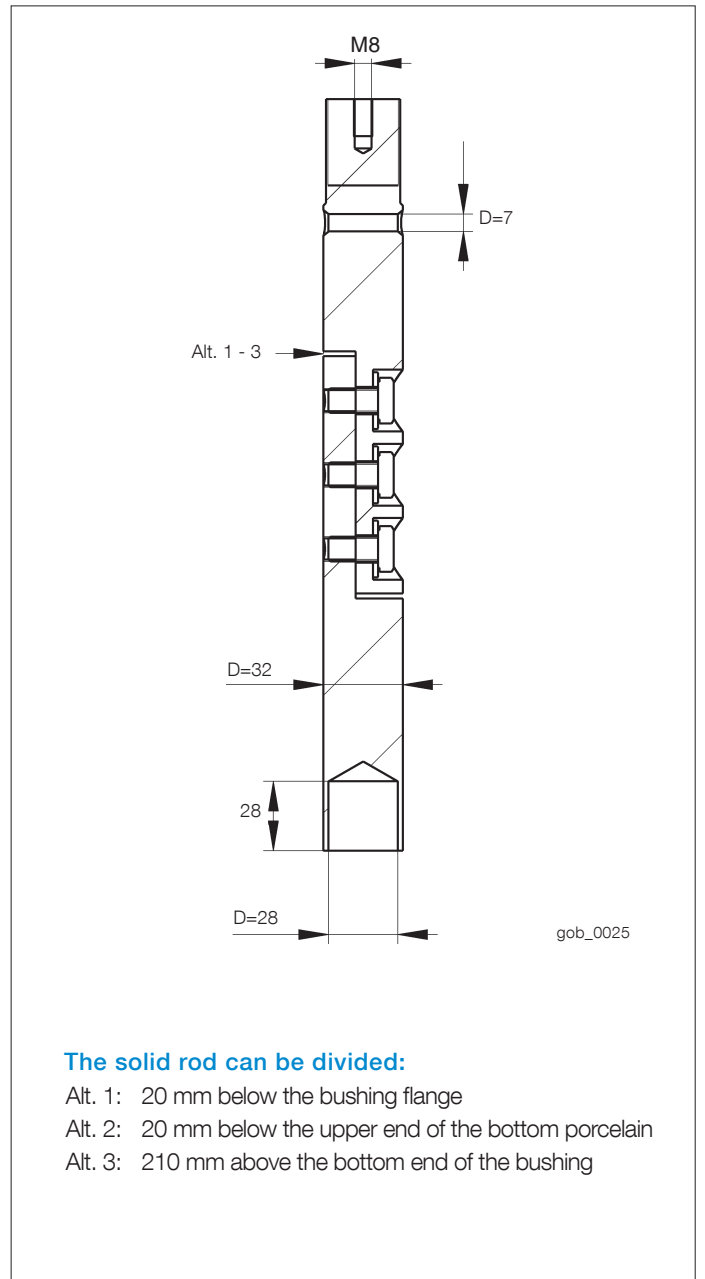

Fig. 17. Solid rod.

Recommendations for positioning

The maximum stresses in the oil at the surface of the shield insulation must be limited to those values normal for insulated conductors and similar components in the same transformer.

The adjacent recommendations are intended as guide lines when complete calculations are not carried out.

Type GOB	Internal insulation level of transformer (kV)	R (mm)
250–800	170–70	65
	250–95	75
250–1250	170–70	75
	250–95	85
325–800	250–95	75
	325–140	100
380–800	325–140	100
	380–150	105
380–1250	325–140	105
	380–150	110
450–800	380–150	105
	450–185	125
550–800	450–185	130
	550–230	155
550–1250	450–185	140
	550–230	160
650–1250	550–230	160
	650–275	185
750–1250	650–275	185
	750–325	210
	1050–1100	240
1050–1100	850–360	240
	950–395	260
	1050–460	300

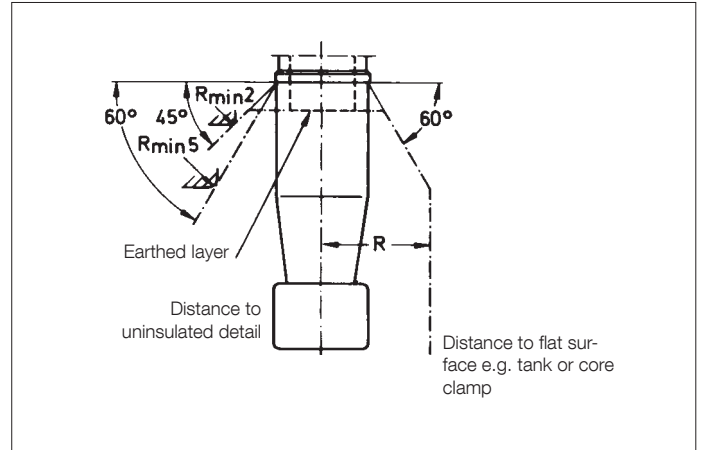

Fig. 18.

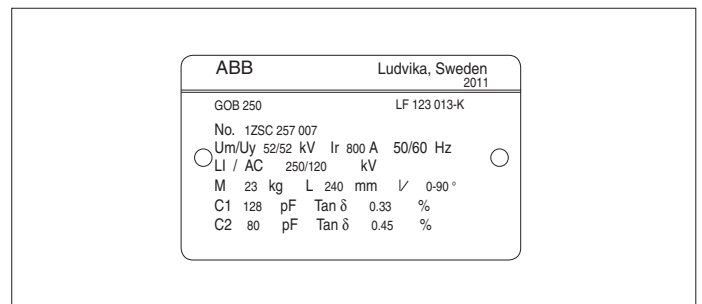

Fig. 19. Nameplate with marking example.

Contact us

ABB AB

Components

SE-771 80 Ludvika, Sweden

Phone: +46 240 78 20 00

Fax: +46 240 121 57

E-Mail: sales@se.abb.com

www.abb.com/electricalcomponents