

# Inertaire<sup>®</sup> Oil Preservation Systems

## Installation, Operation, & Maintenance Guide

### Types RN\_ \_

IZUA 7633-210en

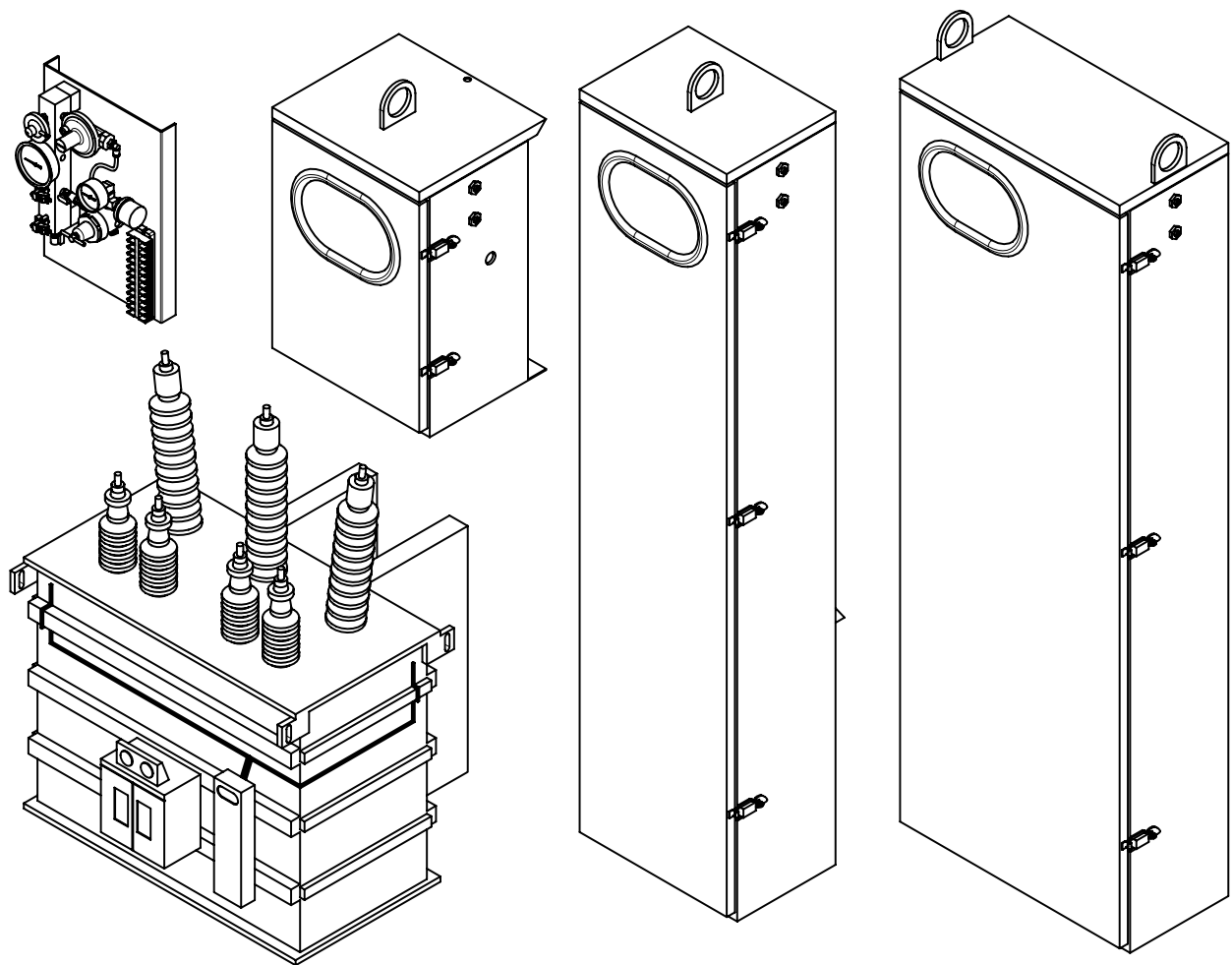

## Scope

This leaflet contains general procedures to be followed for installation and operation of this equipment. These instructions do not purport to cover all possible contingencies which may arise, or all details and variations of the equipment. If additional information is required, contact the nearest representative of ABB Inc.

## Contents:

### 1. Product Description

1.1	General Description .....	2
1.2	Product Identification .....	2
1.3	Detailed Equipment Descriptions	
	A. Enclosures .....	3
	B. Hose Assemblies .....	3
	C. Active part .....	5
	D. Premium Electrical Package .....	7
	E. Tubing Kits .....	8

### 2. Installation

2.1	Safety .....	8
2.2	RNA_ .....	9
2.3	All other units	
	A. Mounting the unit onto the transformer ...	9
	B. Connecting the low-pressure tubing .....	9
	C. Connecting electrical leads and wiring ..	15

### 3. Operation

3.1	Replacing/connecting a nitrogen cylinder ..	15
3.2	Adjusting the 2 <sup>nd</sup> Stage Output Pressure and Testing the Pressure Relief Unit .....	16
3.3	Purging the Gas Space .....	17
3.4	Tank Leak Test .....	17
3.5	Sampling the Gas Space.....	18
3.6	First month of operation .....	18

### 4. Maintenance

4.1	Annual Inspection.....	18
4.2	Inertaire® System Record .....	18

### 5. Renewal Parts .....

## 1. Product Description

### 1.1 General Description

The Inertaire® nitrogen gas control system includes all of the pressure regulating components and controls which are needed to maintain a positive pressure, nitrogen atmosphere in the gas space of a transformer. This nitrogen blanket protects the transformer's oil from deterioration caused by exposure to moisture or oxygen. The nitrogen gas cylinder and the external tubing and fittings required to connect the Inertaire® system to the transformer gas space are not included; however they can be purchased separately.

The standard factory settings for the low and high pressure limits are: +0.5 psi [+ 3.4 kPa] minimum pressure and + 6.5 psi [+ 44.8 kPa] maximum pressure. Each Inertaire® system has a nameplate showing its settings (see Figure 1).

When gas space pressure falls below the low pressure limit, the Inertaire® system automatically feeds fresh nitrogen into the transformer gas space until the gas space pressure is restored to a value above the low pressure limit.

When the gas space pressure exceeds the high pressure limit, the Inertaire® system automatically vents excess pressure to atmosphere through the pressure relief unit.

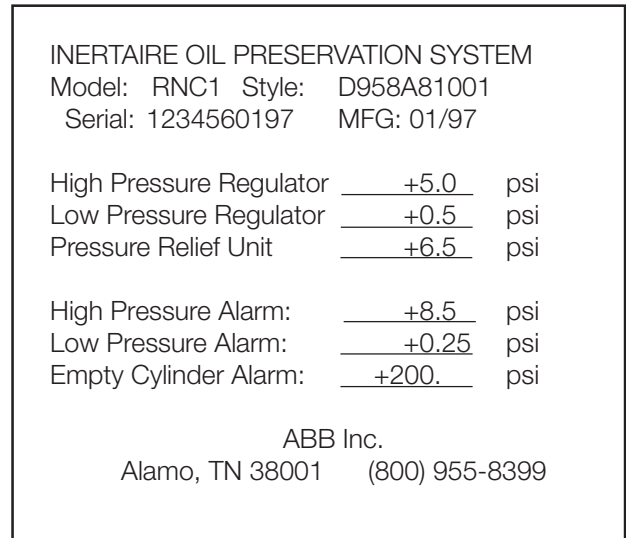

Figure 1: Sample nameplate.

### 1.2 Product Identification:

Standard models of Inertaire® systems are identified with the following 4 character scheme. The first two characters “RN” are for “Regulated Nitrogen”, the third character identifies the enclosure size, and the fourth character identifies certain equipment options. The cover of this leaflet shows each of the four basic configurations and their designations:

Model		RNA_		RNB_		RNC_		RND_	
Features	Package Option	1	2	1	2	1	2	1	2
Stainless Steel Bottom	None	Yes, Welded		Yes, Removable					
Stainless steel draw latches with padlocking provisions		2		3					
Stainless Steel Hinges		2		3					
Door Activated Lamp Heater with thermostat GFI Outlet (Duplex) Aux switch wired to block Ground point on block	No	Yes	No	Yes	No	Yes	No	Yes	

Table 1: Features of standard models.

RN\_\_

- > Equipment Options:
- 1 - Basic equipment only
- 2 - Basic + Premium Electrical Package
- X - Special designation assigned

-> Enclosure size:

- A - Active part only (no enclosure)
- B - Baby box (no space for cylinder in box)
- C - Cylinder mounting space in box
- D - Double cylinder mounting space in box

### 1.3 Detailed Equipment Description:

#### 1.3.A. Enclosures:

RNA\_ models do not include an enclosure. They are intended for mounting within a customer's control cabinet or other customer supplied enclosure. This package includes everything except items that are an integral part of the enclosure (see section 1.3.C and 1.3.D for detailed description). All devices are preassembled and mounted to the standard panel. Each RNA\_ unit is supplied with a nameplate affixed to the panel.

RNB\_, RNC\_ and RND\_ units include NEMA 3R enclosures, with an upper ventilation slot beneath the cover. The door has gaskets along the top and sides while the bottom allows exhaust gas to exit and fresh air to enter the enclosure.

The enclosure is constructed of 0.120 inch [3 mm] [11 gauge] steel. All enclosure surfaces receive 3 mils [0.076 mm] of ANSI 70 grey paint. A gasketed 10 inch by 6 inch [254 mm x 152 mm] Lexan™ window permits viewing of gauges without opening the door. A formed stainless steel plate mounted to the inside of the door serves as a print pocket and has simple operating instructions etched and filled into its surface.

Stainless steel hinges are attached to the left edge of the door, and stainless steel draw latches with padlocking provision are provided along the door's right edge. An automatic door prop holds the door in an open position of approximately 130° until released.

RNB\_ units have a welded-in stainless steel bottom with two drain holes.

RNC\_ and RND\_ units have a bolted-in stainless steel floor with a "lipless" threshold. A Velcro™ strap allows each cylinder to be quickly cinched against the enclosure walls. If the cabinet is mounted near grade level, a customer may choose to remove the floor and allow the gas cylinder to rest directly on grade in order to avoid lifting the gas cylinder. The padlockable enclosure still protects the product from weather and unauthorized access.

#### 1.3.B. Hose Assemblies:

A 24 inch [610 mm] high-pressure hose assembly is included with each unit, and allows connection of the Inertiaire® systems high pressure regulator to the customer's nitrogen cylinder(s). The regulator end of each hose is a 1/4 inch NPT (ANSI- National Pipe Thread) male thread. The cylinder end of each hose has a CGA (Compressed Gas Association) 580 male connector with an integral check valve which prevents gas escaping from the Inertiaire® system. Figure 2 shows the hose configurations available for various units.

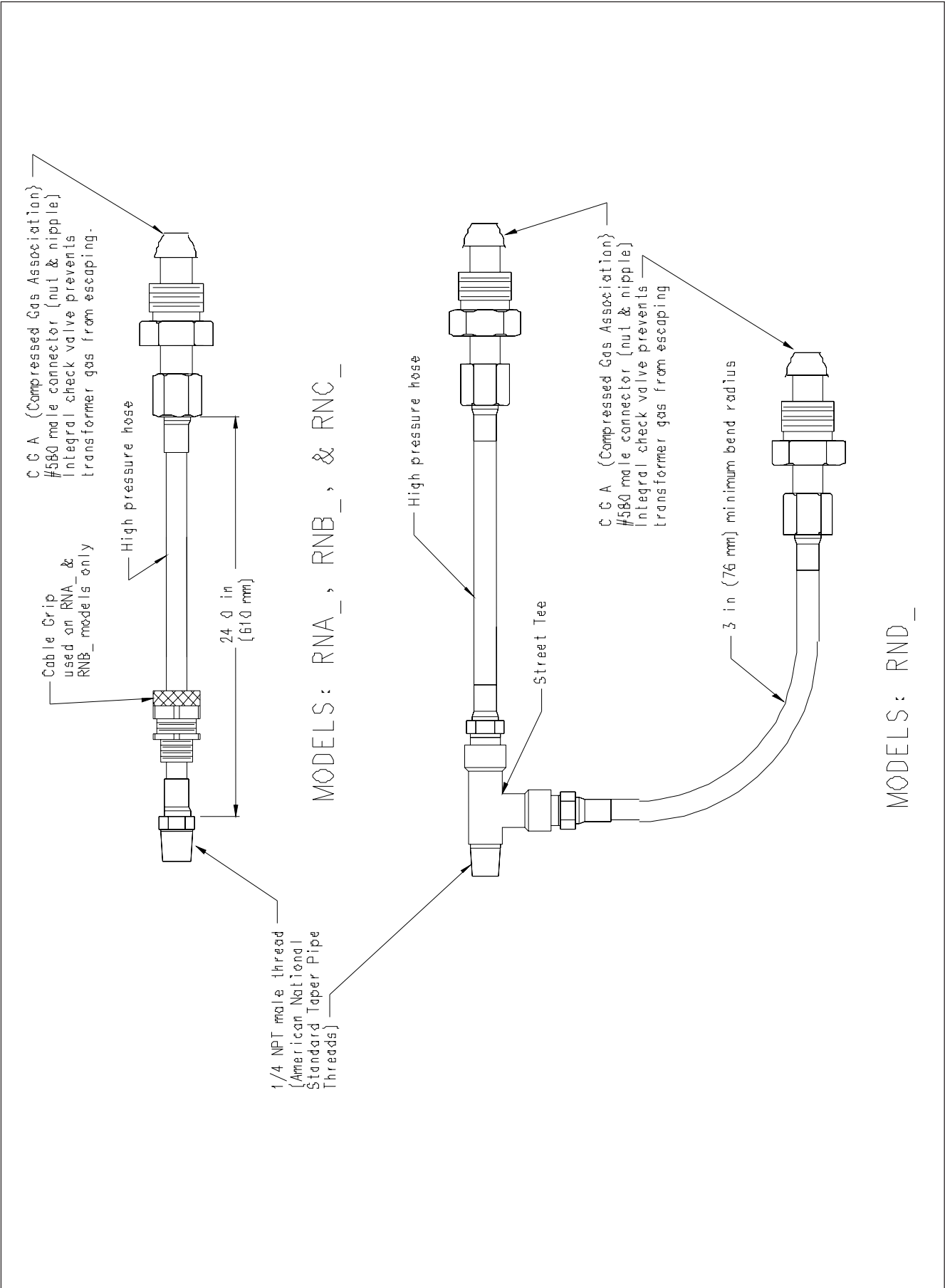

Figure 2: High pressure hose assemblies.

### 1.3.C. Active Part

Figure 3 shows key components of the Inertiaire® system's "active part" which mounts on vibration dampeners within the enclosure. The active part's mounting panel is constructed from 11 gauge (0.120 inch [3 mm]) steel coated with 5 mils [0.127 mm] of white acrylic enamel paint.

Within Figure 3, parts identified by a number inside a circle are common to all models and are described in the numbered paragraphs below. Parts identified by a letter inside a square are included in RN\_2 models only and are described in section 1.3.D.

1. Cylinder Pressure Gauge: This 0-3000 psi gauge (0-20,684 kPa) displays the pressure on the input side of the High Pressure Regulator.
2. Empty Cylinder Alarm Switch: A "Form C" (change over) contact within this pressure switch changes state when the pressure drops below the Empty Cylinder Alarm setpoint (200 psi [1,379 kPa], standard). The terminal points may be wired to a customer's alarm system (see Figure 9 for schematic and switch ratings).
3. High Pressure Regulator: This unit contains two individual stages. The first stage reduces the cylinder pressure (approximately 2000 psi [13,789 kPa] when cylinder is full) to approximately 100 psi [689 kPa] in order to provide constant pressure and flow to the second stage as the cylinder pressure drops. The second stage further reduces the gas pressure to required levels.  
  
The T-handle on the face of the regulator can be used to adjust the output from the second stage. Turning the T-handle counter-clockwise (CCW) lowers the pressure, clockwise (CW) raises the pressure. A jam nut on the handle shaft can be tightened against the regulator's face to secure the handle at the desired setting. The operating setting is shown on the nameplate (+5.0 psi [34 kPa], standard).
4. Low Pressure Regulator: This regulator is factory set to feed nitrogen into the transformer gas space when the gas space pressure falls below (+0.5 psi [3.4 kPa], standard). This unit isolates the gas space from the nitrogen supply when the gas space pressure is above its setpoint. The setting on this regulator should not be changed.
5. Bypass Valve: In the closed position (Operating Configuration), this valve directs the output of the High Pressure Regulator to the Low Pressure Regulator. When the bypass valve is in the open position, it directs the output of the High Pressure Regulator to the sump, bypassing the Low Pressure Regulator. The open position is used to test the operation of the Pressure Relief Unit, purge the transformer gas space, and test the system for leaks.
6. Sump: The sump serves as a collection point for any moisture or oil condensate that may accumulate within the system. It also serves as a manifold for mounting various components of the Inertiaire® system. A drain cock at the bottom of the sump permits draining of accumulated fluid and manual purging of excess pressure during testing or calibration.
7. Pressure/Vacuum Gauge: The 4 inch [102 mm] diameter dial indicates pressure on a -10 to +10 psi scale [-69 to +69 kPa]. With the system in Operating Configuration, the gauge indicates the pressure of the transformer's gas space. The gauge is also used during adjustment of the High Pressure Regulator and testing of the Pressure Relief Unit.
8. Pressure Relief Unit: The setting for this unit is listed on the nameplate (+6.5 psi [+ 44.8 kPa], standard). When the pressure in the transformer gas space exceeds the setpoint, excess pressure vents through the two ports in the rear of the unit. When the pressure drops below the setpoint value, the unit reseals automatically.
9. High Pressure Alarm Switch: The "Form C" contact within this switch operates when the pressure exceeds the setpoint limit (+ 8.5 psi [+58.6 kPa], standard). It automatically resets after the pressure has decreased below the setpoint by a deadband value of approximately 0.75 psi [5.2 kPa]. Excess system pressure can occur if the pressure relief unit fails, or if system pressure increases more rapidly than it can be relieved.
10. Low Pressure Alarm Switch: The "Form C" contact within this switch operates when the pressure falls below the setpoint limit (+ 0.25 psi [+ 1.7 kPa], standard). It automatically resets after the pressure has increased to exceed setpoint by a deadband value of approximately 0.1 psi [0.7 kPa]. A low pressure condition can occur after the nitrogen cylinder is exhausted, or if some system component malfunctions.
11. Terminal Block with clear cover: This 12 point terminal block enables customer's connection to the three alarm switches (Empty Cylinder Alarm, High Pressure Alarm, and Low Pressure Alarm). See wiring diagram in Figure 9. Wiring is 14 AWG minimum type SIS VW-1 with insulated ring-tongue terminals. The block is rated 30 amps and has #10-32 screws for securing terminals.
12. Outlet Valve and Bulkhead Adapter: The outboard side of this valve is intended for connection to a 1/4 inch NPT male fitting and tubing leading to the transformer gas space. In the closed position, this valve isolates the Inertiaire® system from the transformer gas space. This position is used when evacuating the transformer, and when testing the Pressure Relief Unit. In the Open position the valve connects the Inertiaire® system to the transformer gas space. This position is used in the standard "Operating Configuration", and for purging and pressure testing the entire system.

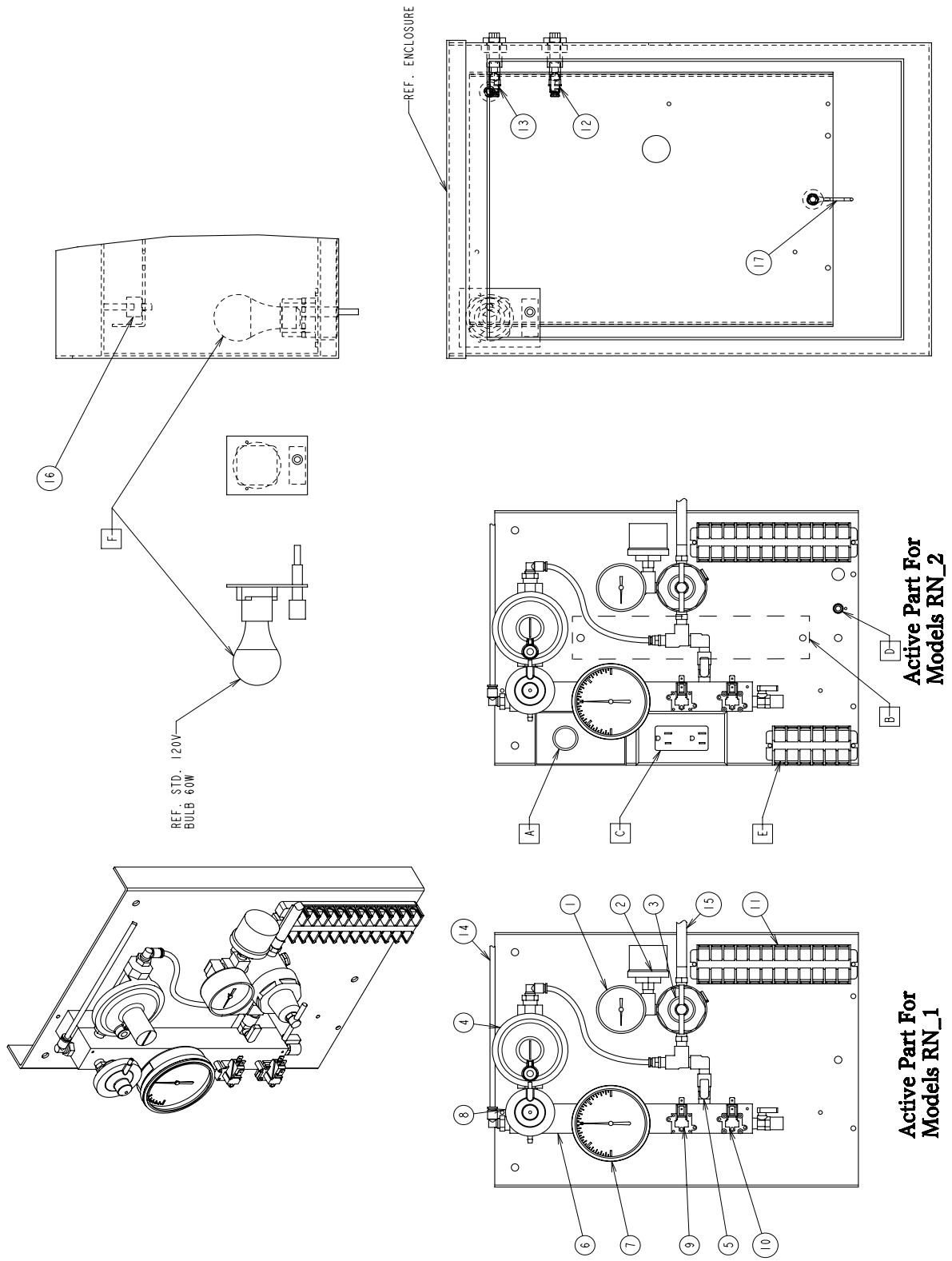

Figure 3: Active part details.

13. Sampling Valve: This valve is intended for connection to the transformer gas space through an independent fitting and length of tubing. The barbed hose connector for 1/4" ID tubing allows gas samples to be obtained from the transformer for testing and analysis. This may also be used as an exhaust port when purging the gas space with fresh nitrogen. During normal operation this valve remains closed.
14. Outlet hose: This hose is approximately 6 inches (152 mm) long and connects the sump (6) to the outlet valve (12).
15. High Pressure Hose: The standard hose is approximately 24 inches (610 mm) long and is used to connect the high pressure regulator(3) to the nitrogen cylinder. The cylinder end of each hose has a CGA (Compressed Gas Association) 580 male connector with an integral check valve which prevents gas escaping from the Inertiaire® system.
16. Vibration dampeners with mounting nuts.
17. Grounding wire: Grounds the active part to the enclosure.

terminals; heater wires have Teflon™ insulation and non-insulated terminals.

#### Mounted Remote from Active Part

- F. A bracket at the top of the cabinet includes a base for a standard 120 volt bulb wired to a door operated switch (i.e. the light is ON only when the door is open). Wiring from the switch and bulb base is run back to the 6 point block on the active part.

#### 1.3.D. Premium Electrical Package:

Additional equipment provided on RN\_2 models is shown in Figure 3 within the square boxes:

On the Active Part:

- A. Thermostat: The adjustable thermostat has an OFF position and an operating range calibrated from + 40° to + 90° F [4° to 32° C, not calibrated].
- B. Space heater: A 250 watt, 240 volt heater strip is mounted to the back of the "Active Part" panel and intended for operation at 120 volts (62.5 watt output) for long life.
- C. Duplex receptacle: This 120 volt outlet with ground fault protection is rated 15 amperes.
- D. Utility Switch: This 3-position (ON-OFF-ON) toggle switch is wired to points 10, 11, and 12 of the 12 point terminal block (see wiring diagram Figure 9). These terminal points may be connected by the user as desired for special requirements such as the following:
  - suppress the low cylinder pressure alarm (e.g. disable alarm while cylinder is being replaced)
  - suppress all remote alarms (when testing locally)
  - generate an alarm signal to test the alarm circuit.
- E. Terminal Block with clear cover: This 6 point block allows connection of the customer's 120 volt single-phase supply to the accessories. A cabinet ground point is also provided on this block. Terminal screws are #10-32. Wiring is 14 AWG minimum type SIS VW-1 with insulated ring-tongue

### 1.3.E. Tubing Kit

Part Number: 1C30327G01

An optional copper tubing kit is available from ABB with the parts needed to connect the Inertaire® system to the transformer gas space.

Each kit contains:

- Four 90° elbow fittings, 1/4 inch NPT male to 0.375 inch outside diameter tubing, two for connection to the 1/4 inch NPT female Bulkhead Adapters on the outside of the Inertaire® system enclosure, and two for connection to the transformer's 1/4 NPT pipe couplings for access to the transformer gas space.
- Two 1/4 inch NPT pipe couplings for welding to the transformer wall above the maximum oil level.
- A 50 foot (15.25 m) length of 0.375 inch outside diameter copper tubing which can be cut and formed as needed to connect the Inertaire® system to the transformer gas space.
- 25 tubing support clamps.

The customer must provide studs on the transformer tank to support the tubing along its length (typically 1.0 inch long #10-32, spaced every linear 3 feet) and hardware to secure the supports to the studs.

## 2. Installation

### 2.1 Safety Information

Keep this Instruction Leaflet available to those responsible for the installation, maintenance, and operation of the Inertaire® system.

The installation, operation, and maintenance of an Inertaire® system presents potentially unsafe conditions, including, but not limited to the following:

- High pressures
- Lethal voltages
- Heavy components

Specialized procedures and instructions are required and must be adhered to when working on such apparatus. Failure to follow instructions could result in severe personal injury, death, and/or product or property damage.

Additionally, all applicable safety procedures such as OSHA requirements, regional and local safety requirements, safe working practices, and good judgement must be used by personnel when installing, operating, and/or maintaining such equipment.

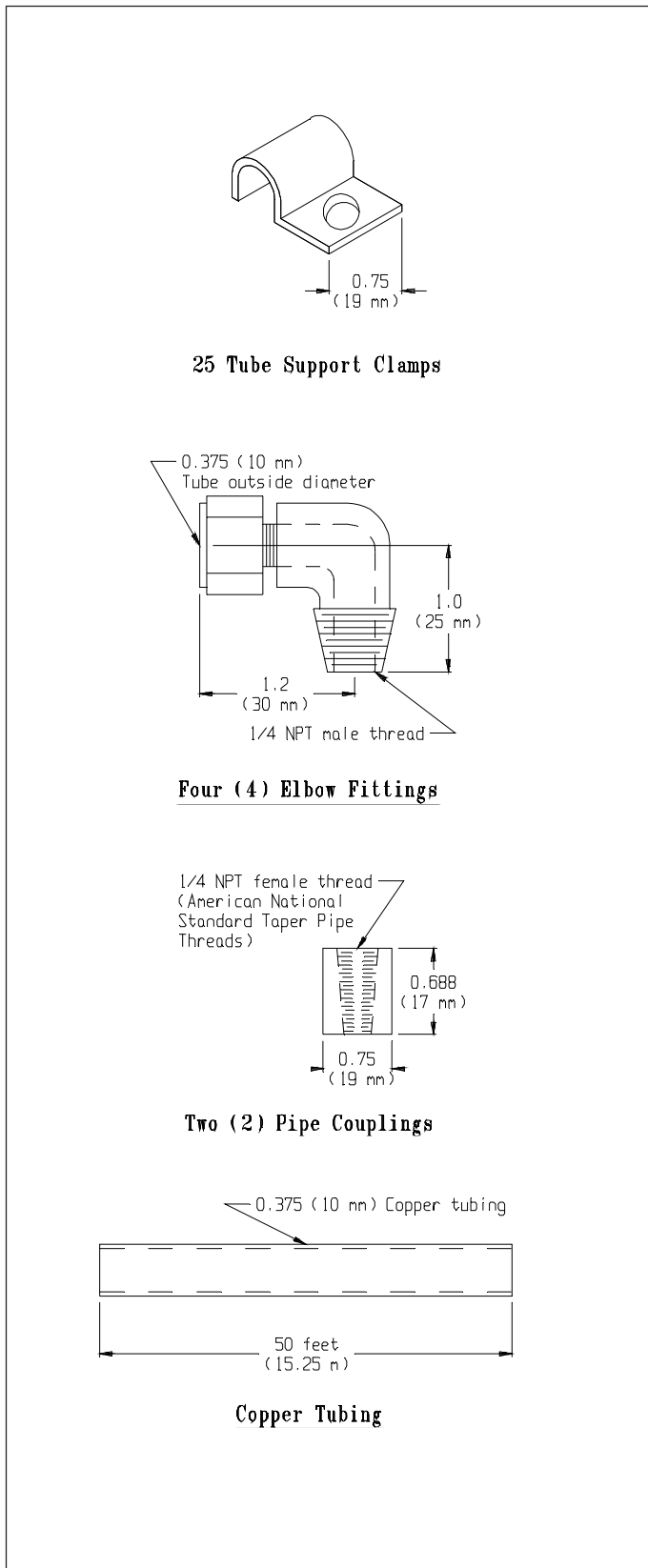

Figure 4: Tubing kit contents.

**Important Notice:** Failure to observe the requirements of OSHA standard 1910.269 can cause death or severe burns and disfigurement. That standard specifically prohibits the wearing of polyester, acetate, nylon, or rayon clothing by employees working with exposure to electric arcs or flames.

Safety notations defined in this instruction leaflet, involve two possible conditions:

1. Personal injury or death.
2. Product or property damage (includes damage to this product or other property).

Safety notations are intended to alert personnel of possible personal injury, death, or property damage. They have been inserted in the instructional text prior to the step in which the condition is cited.

The safety notations are headed by one of three hazard intensity levels which are defined as follows:

1. DANGER--immediate hazard which will result in severe personal injury, death, or property damage.
2. WARNING--hazard or unsafe practice which could result in severe personal injury, death, or property damage.
3. CAUTION--hazard or unsafe practice which could result in minor personal injury, or property damage.

## 2.2 Installation for RNA\_models (without enclosure)

- a. Cut openings in the enclosure for bulkhead adapters, cable entrance, and hose passage as needed (for typical dimensions see Figure 5).
- b. Install the three shock mounts onto 1.5 inch (38 mm) long, 0.313-18 studs within enclosure. Secure "Active Part" panel onto the mounts with hardware as shown in Figure 5. Note the grounding scheme on lower mounting stud.
- c. If cylinder is to be mounted outside the enclosure, disconnect hose from high pressure regulator. Route hose through the wall of the enclosure using the provided cable grip to seal the opening. Reconnect the hose to the regulator after applying a light coating of thread sealant on the threads.
- d. Secure the bulkhead connectors for the outlet valve and sampling valve through the right wall of the enclosure so valve knobs face forward (see Figure 5).
- e. Connect the tubing from the sump to the outlet valve.
- f. If applicable, mount the light assembly so that the door activated switch will compress approximately 0.75 inches (19 mm) when the door is in the closed position.

## 2.3 Installation for models RNB\_, RNC\_, & RND\_

### 2.3.A. Mount the enclosure onto the transformer.

Three mounting holes are provided in the brackets on the rear of each ABB enclosure. The Inertiaire® system's brackets should rest on the transformer's supports and be connected by a bolt,

flat washers, lock washer and nut (not included) as shown in Figures 6 & 7. If there is a gap between the transformer bracket and the enclosure bracket, one or more washers should be used to shim as necessary to distribute the enclosure's weight between the upper and lower brackets.

### 2.3.B. Connect the low-pressure tubing from the enclosure to the transformer gas space.

Section 2.3.B. assumes the optional ABB tubing kit has been purchased. While the instructions that follow can be used as general guidelines, please refer to the assembly instructions provided by supplier of tubing and fittings if the optional ABB tubing kit is not purchased.

The customer must weld the two 1/4 inch NPT female couplings to the transformer wall to provide access to the transformer gas space. Some transformer designs locate the couplings side-by-side, whereas others place the couplings at diagonally opposite corners near the top of the transformer for a cross-flow of gas.

Cut tubing to length, deburr and bend as required. Verify that the tubing is free of debris.

Using a light coating of thread cement or Teflon™ tape, attach two elbows into the female 1/4 inch NPT female bulkhead fittings on the right wall of the Inertiaire® system's enclosure. When tight, these elbows should point upward at an angle of about 30° from vertical toward the transformer wall. See Figure 8.

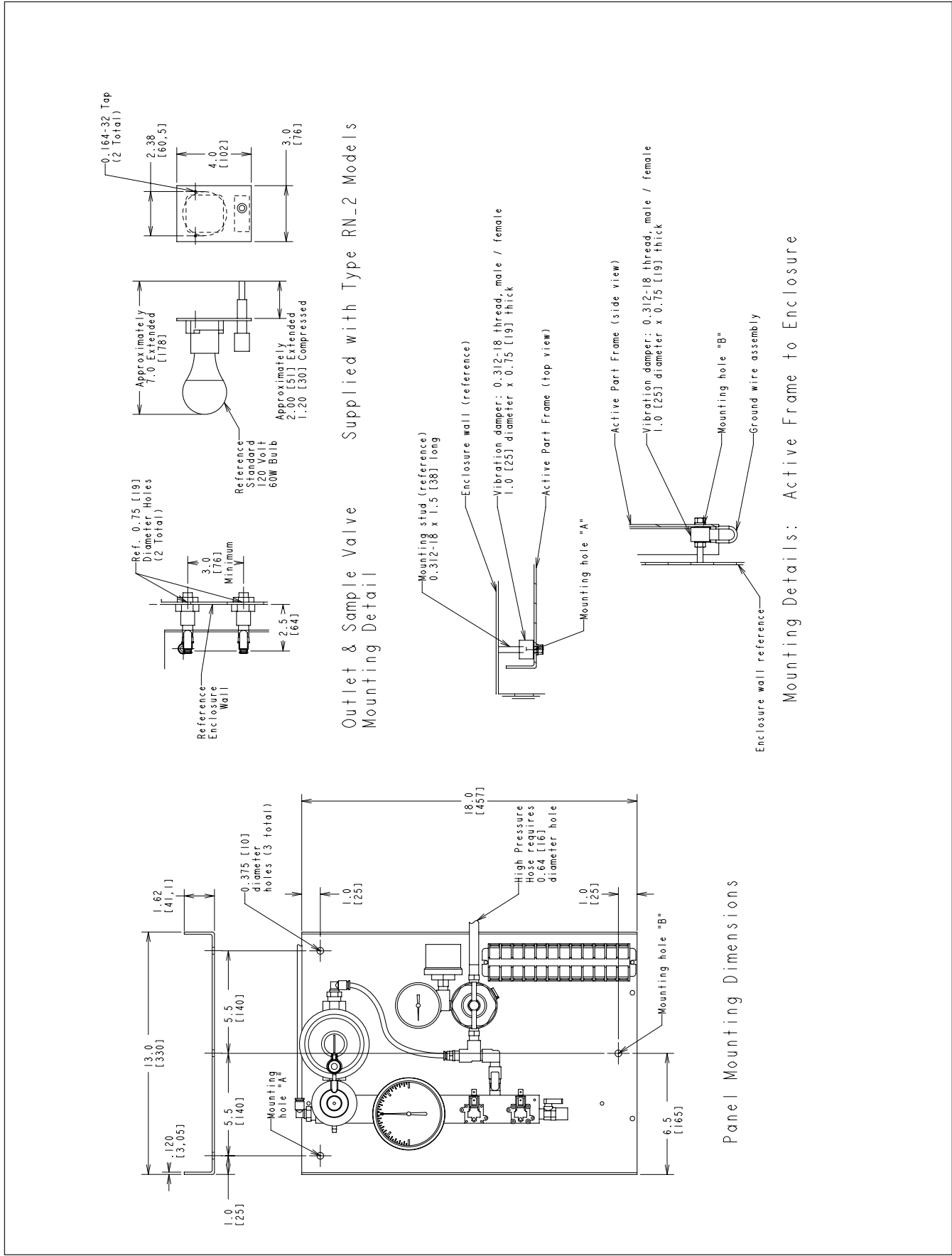

Figure 5: Key dimensions for mounting RNA\_ unit within an enclosure.

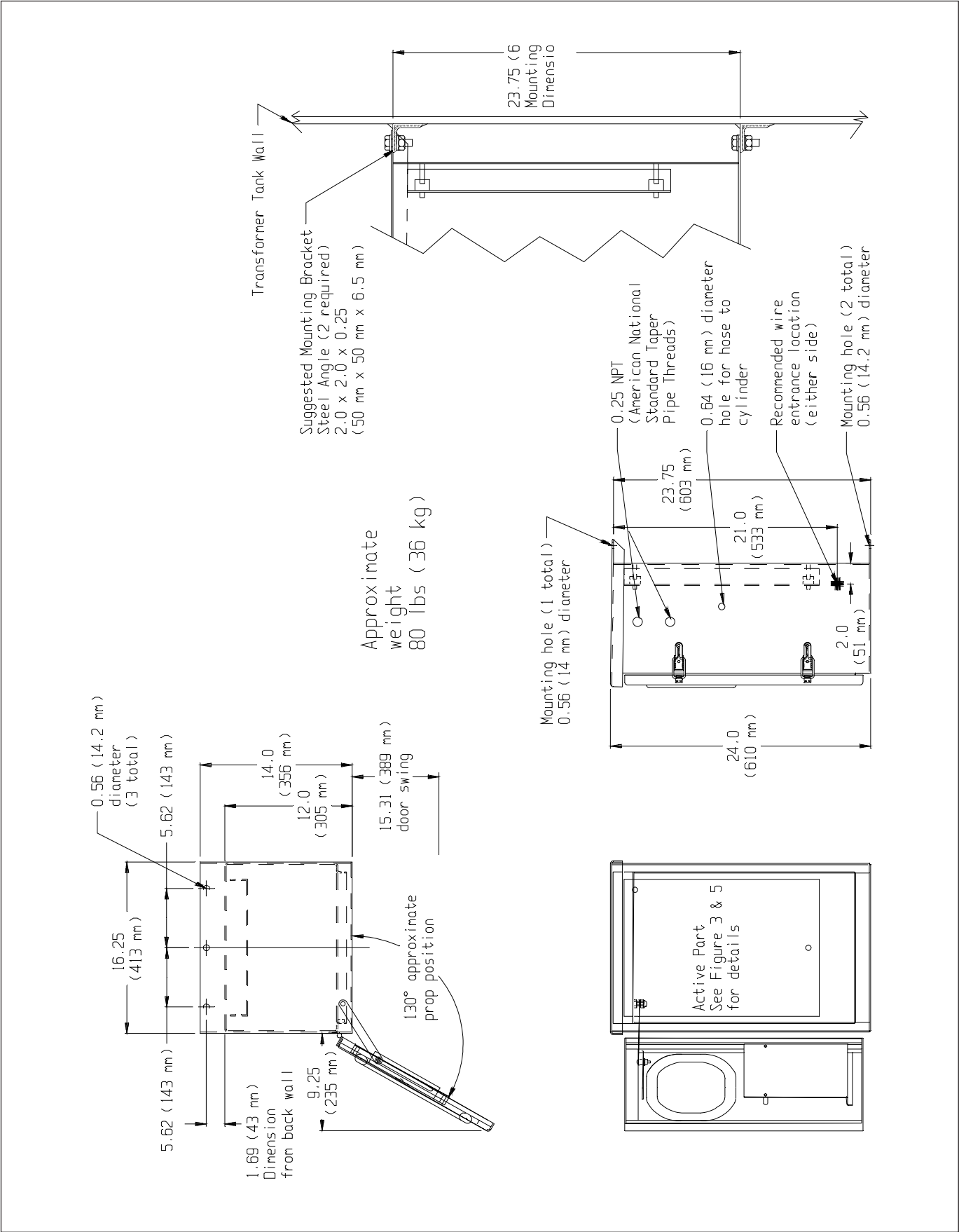

Figure 6: Mounting the RNB\_ enclosure on a transformer.

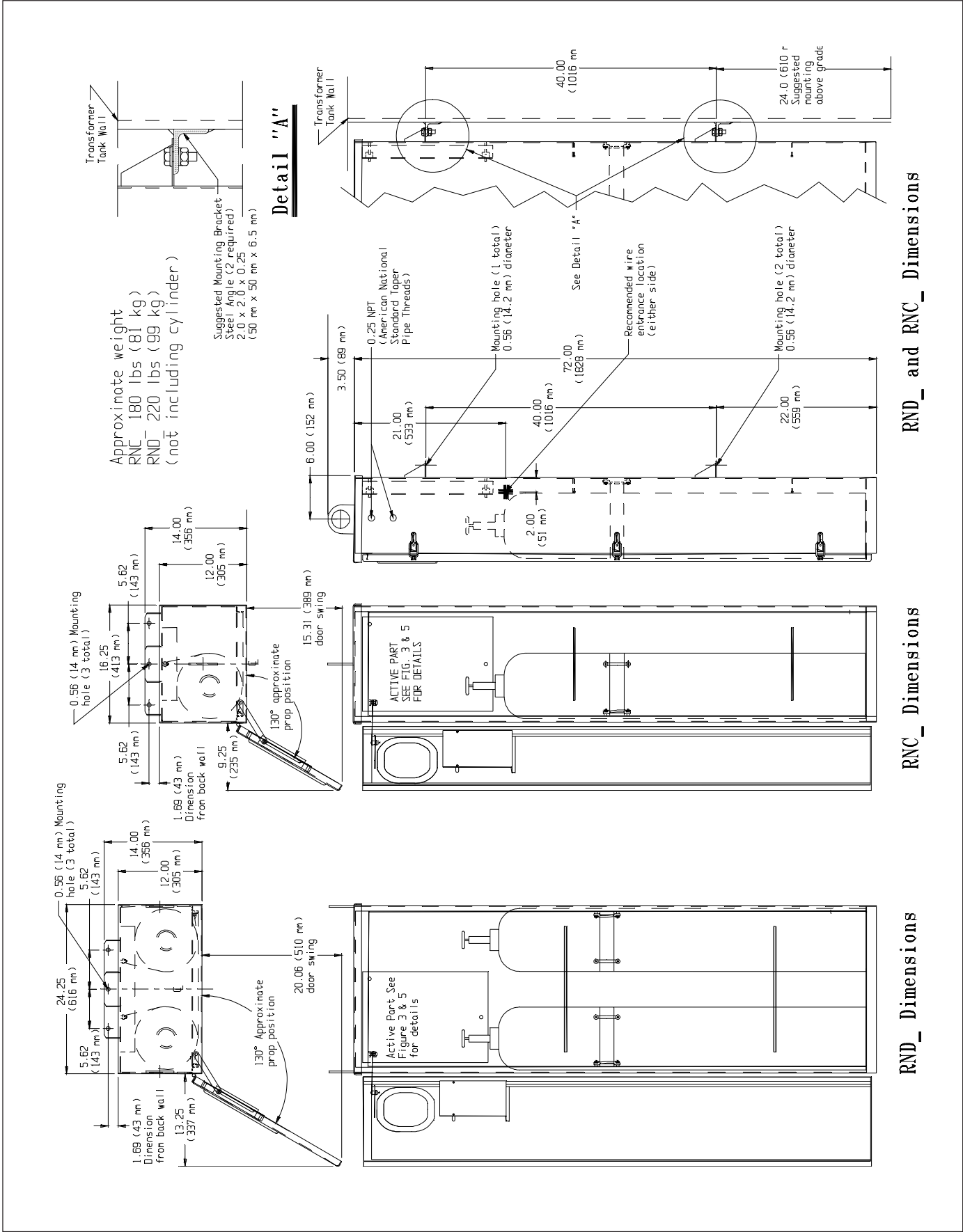

Figure 7: Mounting the RNC\_ and RND\_ enclosure on a transformer.

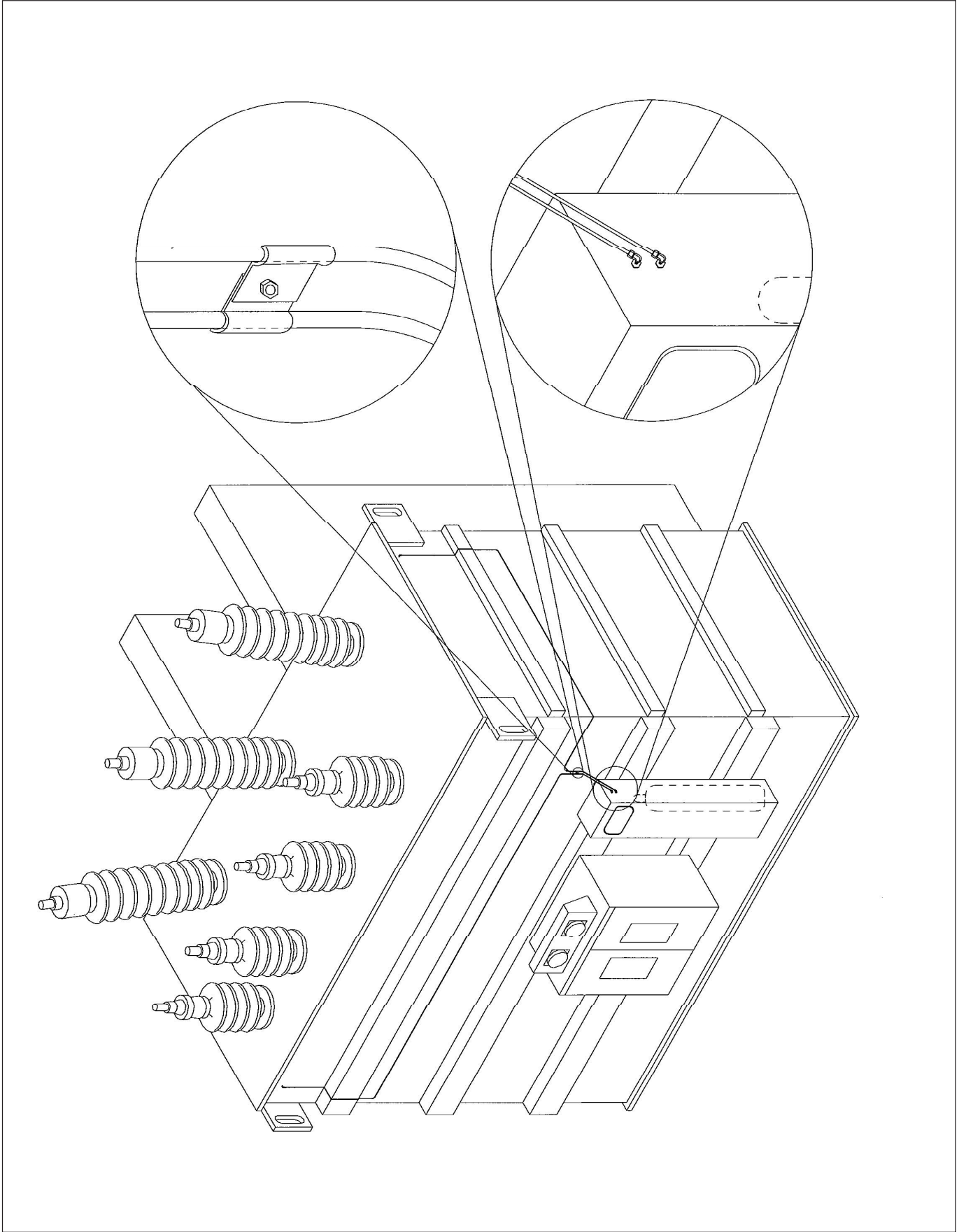

Figure 8: Connection of tubing to the bulkhead connectors.

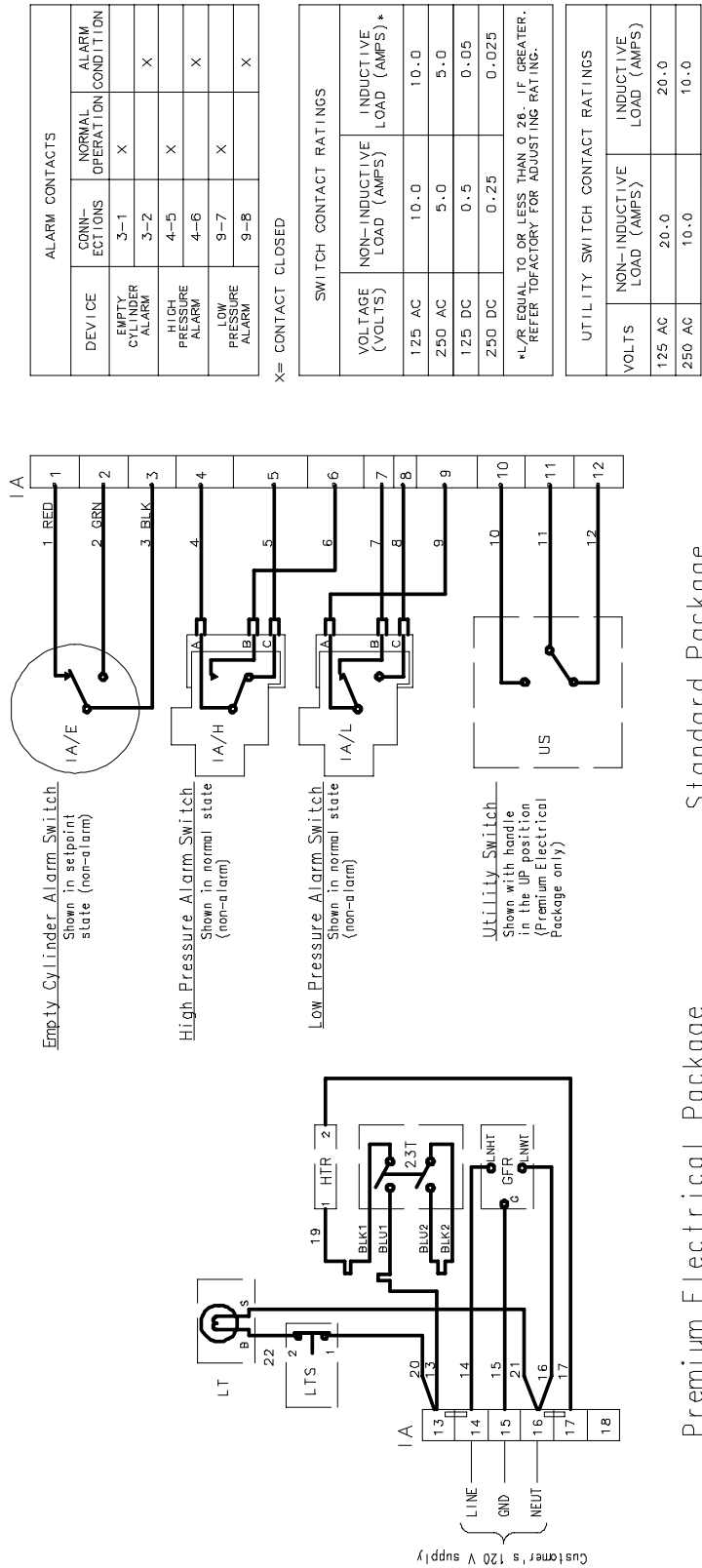

Figure 9: Schematic diagram for standard Inertaire® system.

Using a similar process, attach the other two elbows to the transformer gas space couplings. The tubing ends should point downward.

The tube fittings come preassembled finger-tight. Insert the tube into the fitting. Make sure that the tubing rests firmly on the shoulder of the fitting and that the nut is finger tight. Scribe the nut at the 6 o'clock position. While supporting the body of the fitting with a back-up wrench, tighten the nut 1.25 turns, watching the scribe mark make one complete revolution and continue to the 9 o'clock position. Repeat this process for each of the four tube connections.

Secure the tubing along its path with supports and hardware as shown in Figure 8.

### 2.3.C. Connect electrical leads and run wiring.

Consult transformer controls wiring diagram for specific connections in the transformer's control scheme. A schematic diagram of the standard Inertiaire® system alarms and other electrical equipment is shown in Figure 9.

1. Cut one or more holes in the enclosure to accommodate the cable or conduit fitting(s) required. Refer to Figures 6 & 7 for suggested location.
2. Install fitting(s) (not included) into the hole(s) and install the wiring.
3. Connect leads to the appropriate terminals on the 12-point terminal block.
4. For RN\_2 units:
  - a. Connect the 120 V Line, Neutral, and Ground leads to the appropriate points on the 6 point terminal block.
  - b. The utility switch is wired to terminal block points 10, 11, and 12, and may be connected to suit.

Two 0.25 inch (6.4 mm) diameter holes along the lower edge of the "Active Part" can be used to secure wiring with wire ties.

## CAUTION

Do not use a low voltage bell ringer when checking the alarm circuits; this could exceed the interrupting ratings of the contacts and may damage the contacts. An indicating light device is best for checking the circuits. Figure 9 lists the interrupting ratings of the alarm contacts.

## 3. Operation (all units)

### 3.1 Replacing/connecting a nitrogen cylinder

When the pressure in the cylinder is below 100 psi (689 kPa) it should be replaced with a full cylinder of nitrogen. The nitrogen used should comply with the requirements of the transformer manufacturer, however the following guidelines are provided for reference:

Cylinder Dimensions:

- Capacity 200 ft<sup>3</sup> [5.66 m<sup>3</sup>]
- (2200 psi @ 70° F)
- [15,168 kPa @ 21° C]
- Height: 55 in [1397 mm]
- Diameter: 9 in [229 mm]
- Weight: approx. 140 lbs [63 kg]

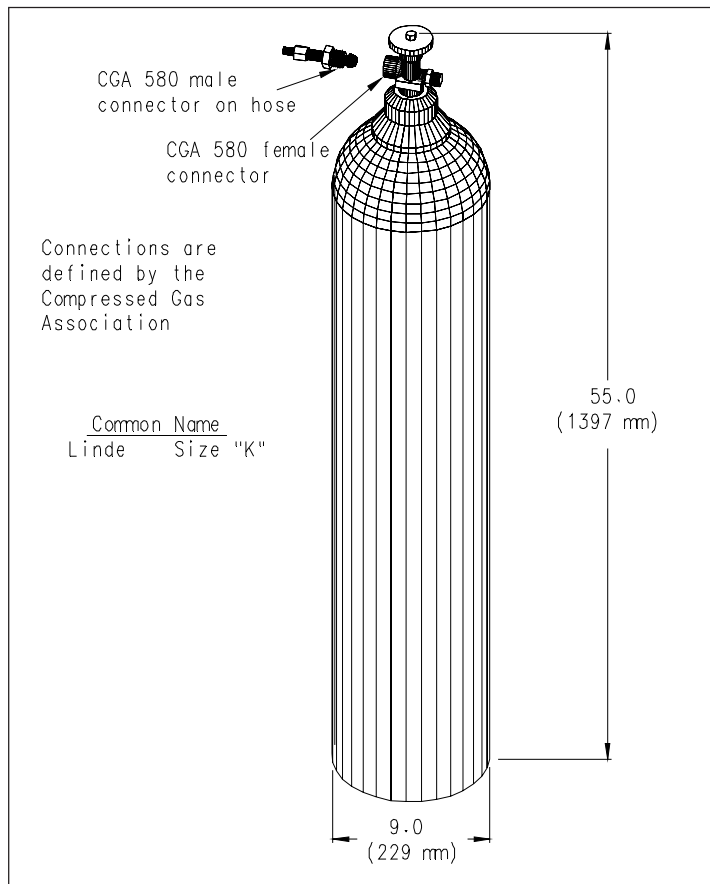

**Figure 10: Typical nitrogen cylinder dimensions for which RNC and RND enclosures are designed to accept. The cylinder is not included with the standard system but may be purchased separately.**

Valve Connection:	CGA 580 Female
Purity:	max impurities 0.20% by volume
Moisture:	Dew Point of -55° C [-67° F] or lower
Oxygen Content:	Maximum 0.20% (2000 ppm) by volume

## WARNING

Always follow this sequence of steps when replacing a nitrogen cylinder. Failure to do so may cause equipment damage or severe personal injury.

This procedure covers the complete process of replacing a nitrogen cylinder; for installation of the initial cylinder begin on step 5.

1. Close the valve on top of the installed nitrogen cylinder by turning clockwise (CW).
2. Close the Inertaire® system's Outlet Valve (CW) to the limit to isolate the transformer gas space from the regulator system.
3. Slowly loosen the connection between the nitrogen cylinder and the Inertaire® system's High Pressure Hose by turning the union nut counter-clockwise (CCW). A small amount of gas should escape from the fitting. Proceed to detach the hose fitting from the cylinder and secure the hose out of the way. If the hose will be left disconnected for more than a few minutes, install a dust cap to prevent entry of dirt or moisture into the system until the new cylinder is ready to install.
4. Release the cylinder strap, swing it out of the way, and remove the cylinder. Install the cylinder valve's protective cap.
5. Verify that the Bypass Valve is closed (CW), so that gas will be directed through the Low Pressure Regulator.
6. Remove the protective cap from the full nitrogen cylinder, and position the cylinder in place. Secure the cylinder with the strap and store the cylinder's protective cap in a safe, convenient location.
7. Be sure the cylinder valve is free of dirt. A good procedure is to briefly open the cylinder valve slightly (CCW) to allow any contamination lodged in the valve to be blown out.

## CAUTION

Point the opening of the valve away from personnel in the area to avoid injury from a high pressure gas stream or from blowing particles.

8. Connect the high pressure hose to the cylinder tightening the union nut only hand tight. Slowly open the cylinder valve slightly and allow the gas leaking out of the connection to blow off any fine dirt. Tighten the union nut with a 1-1/8 inch wrench until the gas leak stops; then open the cylinder valve (CCW) to the fully open position.

## CAUTION

Opening the cylinder valve should be done very slowly to avoid damage to the valve seat. Always backseat the open valve with the same force that would be used to close the valve. Failure to observe these precautions may cause equipment damage or personal injury.

9. Briefly open the drain cock on the bottom of the Inertaire® system's sump by turning the wings counter-clockwise (CCW). When only dry gas exits the sump, close the drain cock (CW).
10. Open the Outlet Valve (CCW) to its limit. The system may operate to stabilize the gas space pressure within its range. Monitor the pressure/vacuum gauge to see that an acceptable level is reached.

The unit is now in "Operating Configuration".

### 3.2 Adjusting the 2<sup>nd</sup> Stage Output Pressure and Testing the Pressure Relief Unit.

This procedure may be performed as part of routine maintenance to verify proper operation of the equipment. The instructions assume that the system is set in the "Operating Configuration" as defined in section 3.1.

1. Read the nameplate inside the Inertaire® system to determine the preset value for the Pressure Relief Unit (standard setting is +6.5 psi (44.8 kPa)).
2. Close the Outlet Valve (CW to limit).
3. Open the Bypass Valve (CCW to limit).
4. Release the 1/2 inch jam nut on the high pressure regulator's T-handle. While watching the pressure/vacuum gauge, turn the T-handle clockwise slowly to increase the pressure. Gas should begin escaping from the Pressure Relief Unit within +/- 0.5 psi (+/- 3.4 kPa) of the setpoint value.

If the Pressure Relief Unit does not operate at the correct value, adjust it with a 5/64 inch (0.078 inch) Allen wrench through the hole in the center of the unit's face. Labeling and arrows on the unit show proper direction.

5. Turn the regulator T-handle counter-clockwise (CCW) to reduce the pressure to its setpoint (+5.0 psi [+34.5 kPa], standard). Excess pressure may be bled by briefly opening the sump's drain cock and watching the pressure/vacuum gauge stabilize.
6. Close the Bypass Valve (CW).
7. Open the Outlet Valve (CCW).

The unit is now back in "Operating Configuration".

### 3.3 Purging the Gas Space

Some transformers are shipped with dry air in the gas space rather than nitrogen to allow breathable gas be present for a technician to attach internal leads and perform other commissioning activities. When the transformer has been prepared for operation, the Inertiaire® system may be used to purge the gas space with nitrogen. Follow the instructions provided by the transformer manufacturer for filling the transformer with oil and gas.

The following procedure may be used generally to purge the gas space. The instructions assume that the system is set in the "Operating Configuration" as defined in section 3.1. Also verify there is adequate nitrogen pressure in the cylinder before beginning the procedure.

## CAUTION

Use extreme care when purging the gas space with nitrogen from a high pressure cylinder. Do not seal the transformer until the nitrogen in the gas space has reached ambient temperature (i.e. Do not close the outlet valve which seals the transformer from the Inertiaire® system's pressure relief unit). As high pressure (up to 2000 psi (13,789 kPa)) nitrogen is reduced to atmospheric pressure and piped to the gas space, the gas expansion reduces its temperature. Unless the gas is free to expand as it warms to ambient temperature, the pressure within the tank may increase to such a value as to operate the relief unit.

1. Close the Outlet Valve (CW).
2. Open the Bypass Valve (CCW).
3. Verify the pressure within the sump is +5.0 psi [+ 34.5 kPa]. Adjust if necessary as described in section 3.2.
4. Open the Outlet Valve (CCW); the Inertiaire® system will work to pressurize the transformer tank to +5.0 psi [34.5 kPa].

5. Open the Sampling Valve (CCW) to exhaust gas from the gas space until gas analysis yields satisfactory results. Close the sampling valve securely when the purge is complete.
6. Close the Bypass Valve (CW).

The unit is now back in "Operating Configuration".

### 3.4 Tank Leak test

A 5.0 psi (34.5 kPa) nitrogen pressure test can be made on the transformer tank and Inertiaire® system. Any small nitrogen leak should result in a change in pressure on the Inertiaire® system's Pressure/Vacuum gauge. After verifying that the adjustment of the T-handle is correct (see 3.2), perform the following procedure:

1. Open the Bypass Valve (CCW) and allow the system to stabilize at +5.0 psi (+ 34.5 kPa). See Caution in section 3.3 regarding expansion of gas from cylinder.
2. Close the nitrogen cylinder valve (CW) and allow the transformer to stand several hours under this pressure. If the pressure falls off with no change in temperature, a leak is present and should be located and corrected.
3. Check all hose connections, valve packing glands, and fittings for signs of escaping gas. A solution of soapy water applied to the joints will bubble where leaks are present.

## WARNING

Be certain all current carrying items have been de-energized before proceeding with this step. Failure to do so could result in electrical shock.

4. Close the Bypass Valve (CW).
5. Open the cylinder valve to limit (CCW).

The unit is now in "Operating Configuration".

### 3.5 Sampling the Gas Space

Before beginning this procedure, verify that there is positive pressure within the transformer gas space by checking the pressure/vacuum gauge for a positive reading, and verify that the nitrogen cylinder has adequate pressure remaining.

1. Open the sampling valve (CCW) briefly to clear the sampling tube of any oil condensate and static gas.
2. Connect a sampling device with 0.25 inch [6.4 mm] inside diameter hose to the barbed hose connection on the sampling valve.
3. Open the sampling valve (CCW) and draw off an adequate gas sample. The Inertiaire® system will function as required to maintain the pressure above the low pressure limit.
4. Close the sampling valve (CW) securely.

### 3.6 First Month of Operation

The amount of nitrogen used by the transformer will depend on the integrity of the transformer tank, the load cycle, and ambient temperature variations. In order to be sure that the equipment is operating correctly and that there are no leaks in the system, ABB recommends the following readings be taken during the first month of operation and recorded on the table on page 19 for analysis:

1. During the first week take daily readings of:
  - a. nitrogen cylinder pressure
  - b. transformer tank pressure as indicated on the pressure/vacuum gauge
  - c. transformer oil temperature
  - d. ambient air temperature

Weekly readings will suffice for the remainder of the month.

2. A weekly oxygen analysis may be performed to determine whether the transformer is operating properly. Additional purging should be done if the oxygen content approaches 5% (this is generally considered to be the safe upper limit to prevent explosions in the gas space). Follow specific instructions provided by the transformer manufacturer with regard to testing and levels.

## 4. Maintenance

Inertiaire® systems are designed to require very little maintenance. Replacement of nitrogen cylinders is described in section 3.1.

### 4.1 Annual Inspection

The following checks should be performed at least once a year.

1. Drain the sump of any accumulated fluid. (see 3.1 step 9).
2. Check the operation of the Pressure Relief Unit (see 3.2).

If the unit is equipped with a cabinet heater, verify that it is operating properly. If the unit has a GFI outlet, test the device for proper operation, and then reset it.

### 4.2 Inertiaire® System Record

Page 19 has an Equipment Record table which can be used to record the condition of the Oil Preservation System over time.

## 5. Renewal Parts

If renewal parts are required, order them through the nearest ABB Inc. representative. Please provide the item description and the identification numbers (model, style, catalog) from the unit's nameplate.

## Technical Support

If a technical question arises regarding the product detailed in this Technical Product Literature contact:

### ABB Inc.

1128 S. Cavalier Drive  
Alamo, TN 38001 USA  
Phone: (800) 955-8399  
(731) 696-5561  
Fax: (731) 696-5269

### Comments

ABB Inc. continually strives to make its instruction literature current, accurate, and easy to understand. Suggestions to improve this document may be sent to: Literature Coordinator fax (731) 696-5269 or use the mailing address on the back cover. For a reply, please include name, company, phone number, and/or fax number.



## DISCLAIMER OF WARRANTIES AND LIMITATION OF LIABILITY

**THERE ARE NO UNDERSTANDINGS, AGREEMENTS, REPRESENTATIONS OR WARRANTIES, EXPRESSED OR IMPLIED, INCLUDING WARRANTIES OF MERCHANTABILITY OR FITNESS FOR A PARTICULAR PURPOSE OTHER THAN THOSE SPECIFICALLY SET OUT BY AN EXISTING CONTRACT BETWEEN THE PARTIES. ANY SUCH CONTRACT STATES THE ENTIRE OBLIGATION OF SELLER. THE CONTENTS OF THIS DOCUMENT SHALL NOT BECOME PART OF OR MODIFY ANY PRIOR OR EXISTING AGREEMENT, COMMITMENT OR RELATIONSHIP.**

THE INFORMATION, RECOMMENDATIONS, DESCRIPTION AND SAFETY NOTATIONS IN THIS DOCUMENT ARE BASED ON OUR EXPERIENCE AND JUDGEMENT WITH RESPECT TO BUSHINGS. **THIS INFORMATION SHOULD NOT BE CONSIDERED TO BE ALL INCLUSIVE OR COVERING ALL CONTINGENCIES.** IF FURTHER INFORMATION IS REQUIRED, ABB INC. SHOULD BE CONSULTED.

**NO WARRANTIES, EXPRESSED OR IMPLIED, INCLUDING WARRANTIES OF FITNESS FOR A PARTICULAR PURPOSE OR MERCHANTABILITY, OR WARRANTIES ARISING FROM COURSE OF DEALING OR USAGE OF TRADE, ARE MADE REGARDING THE INFORMATION, RECOMMENDATIONS, DESCRIPTIONS, AND SAFETY NOTATIONS CONTAINED HEREIN.** IN NO EVENT WILL ABB INC. BE RESPONSIBLE TO THE USER IN CONTRACT, IN TORT (INCLUDING NEGLIGENCE), STRICT LIABILITY OR OTHERWISE FOR ANY SPECIAL, INDIRECT, INCIDENTAL, OR CONSEQUENTIAL DAMAGE OR LOSS WHATSOEVER INCLUDING BUT NOT LIMITED TO DAMAGE TO OR LOSS OR USE OF EQUIPMENT, PLANT OR POWER SYSTEM, COST OF CAPITAL, LOSS OF PROFITS OR REVENUES, COST OF REPLACEMENT POWER, ADDITIONAL EXPENSES IN THE USE OF EXISTING POWER FACILITIES, OR CLAIMS AGAINST THE USER BY ITS CUSTOMERS RESULTING FROM THE USE OF THE INFORMATION, RECOMMENDATIONS, DESCRIPTION, AND SAFETY NOTATIONS CONTAINED HEREIN.



ABB Inc.  
1128 S. Cavalier Drive  
Alamo, TN 38001, USA  
Telephone: 731-696-5561  
Toll Free: 800-955-8399  
Fax: 731-696-5269  
[www.abb.com/electricalcomponents](http://www.abb.com/electricalcomponents)