

Shunt Reactors

ABB Variable Shunt Reactors Applications

The ABB shunt reactor is the most cost efficient piece of equipment for maintaining voltage stability on the transmission lines. It does this by compensating for the capacitive charging of the high voltage AC-lines and cables, which are the primary generators of reactive power. The reactor can be seen as the voltage control device which is often connected directly to the high voltage lines.

The reactance of a transmission line consumes reactive power along the line when it is loaded. When the line is not loaded or only slightly loaded the reactive power consumption is low. The generation of reactive power dominates, resulting in a voltage increase along the line that can reach dangerous levels for the system. To avoid this phenomenon, the shunt reactor consumes the reactive power, thus stabilizing the voltage along the line.

The transmission line is working at its natural load, also called Surge Impedance Load, when there is a balance between generated and consumed reactive power. At this loading point the voltage profile along the line is ideal and no reactive power compensation is needed. If the line is loaded above its natural load the consumption of reactive power will be higher than that generated and thus the voltage will decrease along the line.

It is possible to fine tune the voltage level by using a so called variable shunt reactor. The inductance of the reactor is changed in steps by an on load tap changer. It is achieved by changing the number of electrical turns in the winding of the reactor. In recent time, this special type of product has gained increasing market interest.

CUSTOMER VALUES

The variable shunt reactor (VSR) can be used for the following situations:

- To reduce voltage spikes in the network when switching in and out the fixed power rated reactors. This situation occurs with networks that have low short circuit power. By changing the VSR to its minimum power tap position this situation can be alleviated. Instead of having two or more reactors with fixed power ratings a single VSR could be used with an associated reduction in the number of circuit breakers and required foot print.
- In substations with SVC equipment and/or rotating phase compensators the VSR could be coordinated with the SVC/phase compensators so as to maximise the dynamic capacity of the network during a network failure.

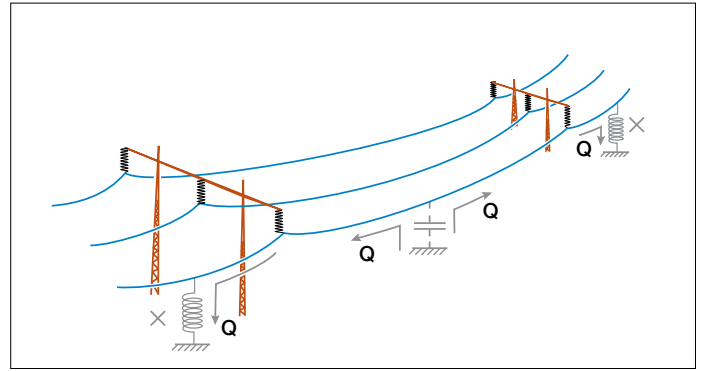

The reactors (X) consume the generated reactive power (Q) from the line.

- For wind park generation applications, a VSR may be the optimal device for controlling reactive power. A switched reactor or capacitor require far too many switching operations and the need for advanced control possibilities of an SVC may not be needed. The reactive-power fluctuations due to a large offshore wind park are an example for which the VSR is a suitable solution.
- It is possible to reduce number of circuit breakers by having one VSR instead of two or more parallel fixed reactors. Maintenance work on breakers will be reduced. Space requirements are reduced by using a single VSR instead of two reactors with fixed ratings.
- Seasonal load variations. To maintain a stable voltage at low loading condition the full Mvar rating is needed. As the load increases in the intermediate season the VSR acts to fine tune the voltage to the required level.
- Daily load variations. The loading varies as a consequence of a more economical way to run the power generation. For this reason there is a need for a more flexible compensation of the reactive power. This can be achieved by regulating the VSR.
- High voltage AC cables. AC cables generate much more reactive power per unit of length than overhead lines and due to thermal constraints in the cable it can normally not be operated at its natural load. Therefore there is a need for reactive power compensation to stabilise the voltage. At variable stationary loads, better fine-tuning of the voltage which leads to a better control of the network can be achieved using a VSR.
- Revisions in the network. In situations like this the demand for reactive power compensation may change. To fulfil the new demand there is a possibility to regulate the VSR.
- Flexible replacement of reactors. During maintenance or a failure situation on another reactor the VSR can adjust its power to fill in as a replacement.

DESIGN

The main function of a VSR is to regulate the consumption of reactive power. This is accomplished by connecting/disconnecting electrical turns in the reactor. The power of the reactor is controlled by the following relation,

$Q \sim (U/N)^2$ where Q: Reactive power; U: Applied voltage; N: Number of electrical turns.

At maximum power rating the minimum number of electrical turns are connected and at minimum power rating the maximum number of electrical turns are connected. This is done by using a tap changer. This is the same type of tap changers used in power transformer applications.

The ABB VSR design is a result of extensive development work in combination with well proven and known technology used in power transformers and reactors. The regulation of the reactor is made by a separate regulating winding located outside the main winding. The taps from the regulating winding are lead to the tap changer. Depending on regulating range, voltage level and loss evaluation the regulating type can be linear, plus-minus or coarse-fine. The design principle of the active part can be seen in the figure below.

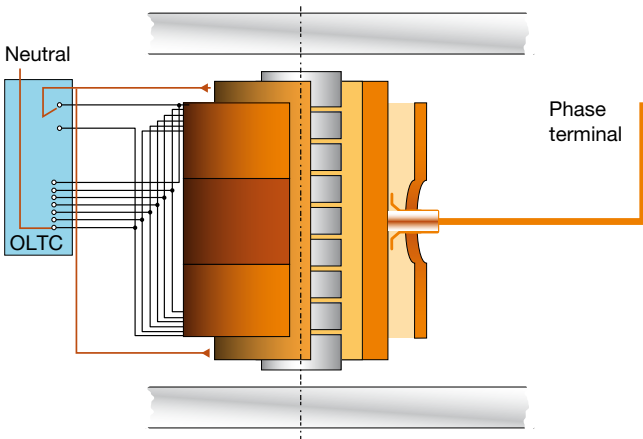

VSR 120-200 Mvar, 420kV

The regulating range is limited by the maximum step voltage and voltage range of the tap changer. Another limitation is the electrical behaviour of the regulating winding at transient voltage stresses. The regulating winding is electrically much longer than a regulating winding used in transformer applications. The feasible regulation range depends on the voltage rating of the reactor according to the following graph.

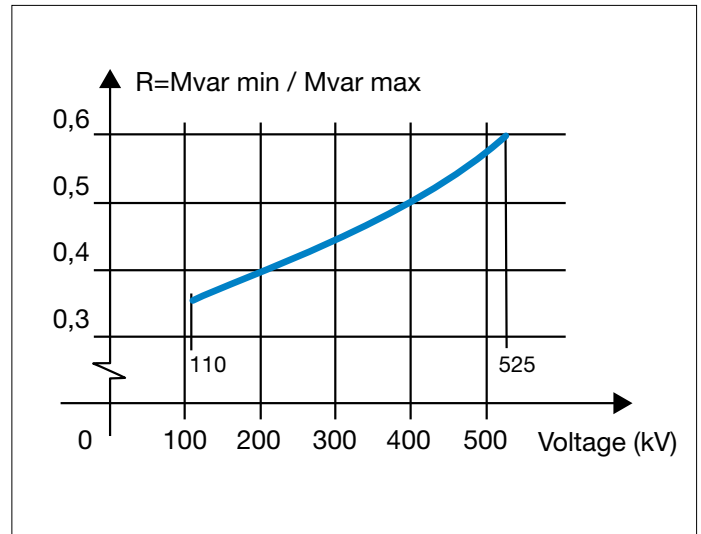

The feasible range is the area above the blue line and the feasible voltages are 110 to 525 kV.

Example using this graph:
 Rated voltage = 225 kV, minimum power = 13 Mvar,
 maximum power = 30 Mvar.

$R = 13/30 = 0,43 \rightarrow \text{OK !}$

REFERENCES

ABB is experienced in the design and manufacture of variable shunt reactors from small to very large units.

Markets: Scandinavia and other countries in Europe, Africa and North America.

Voltage ratings: From 110 to 420 kV.

Power ratings: Regulating range from 7-16 (at 132 kV) to 120-200 (at 420 kV) Mvar.

Accessories: ABB tap changers
 ABB bushings, IEC and ANSI/IEEE type.

Deliveries: From 1989.

Contact us

ABB AB

Power Transformers

SE-771 80 Ludvika, Sweden

Phone: +46 240 78 20 00

Fax: +46 240 131 60

E-Mail: trafo.info@se.abb.com

www.abb.com