

Transformer bushings, type GOM

Technical guide



This Technical Guide has been produced to allow transformer manufacturers, and their designers and engineers, access to all the technical information required to assist them in their selection of the appropriate Transformer Bushing. The Guide should be used in conjunction with the *Selection Guide* to allow the optimum selection to be made.

The technical information pertaining to bushings manufactured by ABB Components has been divided into separate documents, with one document for each type.

The information provided in this document is intended to be general and does not cover all possible applications. Any specific application not covered should be referred directly to ABB Components AB, or its authorized representative.

ABB Components AB makes no warranty or representation and assumes no liability for the accuracy of the information in this document or for the use of such information. All information in this document is subject to change without notice.

ABB Components also manufactures the following products:

- Wall bushings
- GIS bushings
- On-load tap-changers
- Motor-drive mechanisms

Table of Contents

Design _____	4
Shed form _____	4
Test tap _____	5
Testing _____	5
Dimensions _____	6
Electrical data _____	7
Common specifications _____	7
Connection details _____	8
Inner terminal _____	8
Solid rod conductor _____	8
Outer terminal _____	8
Data for end-shield _____	9
Arcing horns _____	9
Conductor loading _____	10
Overload capacity of bushings _____	10
Short-time current _____	10
Dynamic current _____	10
Ordering particulars _____	10
Recommendations for positioning _	11

Design

The bushing is built up around a centre tube on which the condenser body is wound.

The upper insulator, the lower insulator and the mounting flange are held between the end nuts by the centre tube. Sealing is accomplished by oil-resistant rubber gaskets in grooves.

A set of springs in the top housing provides adequate pressure on all gaskets, independent of temperature and load conditions.

The annular space between the condenser body and the porcelain is filled with transformer oil.

The top housing has expansion space for the oil sufficient for temperature variations in the bushing between -40° and $+80^{\circ}\text{C}$. Variations in the length of the centre tube are compensated by the flexible cover of the housing. The top housing is equipped with two oil sight glasses.

The inner terminal is attached to the centre tube by means of a divided ring at the top of the centre tube, which becomes locked when the outer terminal is screwed on. The inner terminal is connected to leads by brazing.

The outer terminal is available in aluminium or copper alloy.

The upper insulator is made of high quality electrical porcelain in brown or light grey colour.

The mounting flange is manufactured of corrosion-resistant aluminium alloy. The flange and the top housing are protected by painting with two-component primer and a grey-blue finishing coat of paint.

The bushings are delivered oil-filled and ready for use. If the bushing is mounted with an inclination of more than 45° from the vertical, special measures may have to be taken to ensure sufficient filling of oil in the bushing. Further information can be obtained by request.

Shed form

The shed form for all GOM bushings is of the anti-fog type with alternating long and short sheds. For each pair of sheds the ratio between nominal creepage distance and the axial length is 3.43 and the ratio between protected and nominal creepage distance is 0.40.

According to IEC 60815 the creepage factor C.F. is <3.2 and the profile factor P.F. is >1.1 .

For special customer demands regarding creepage distance, other shed forms may be used.

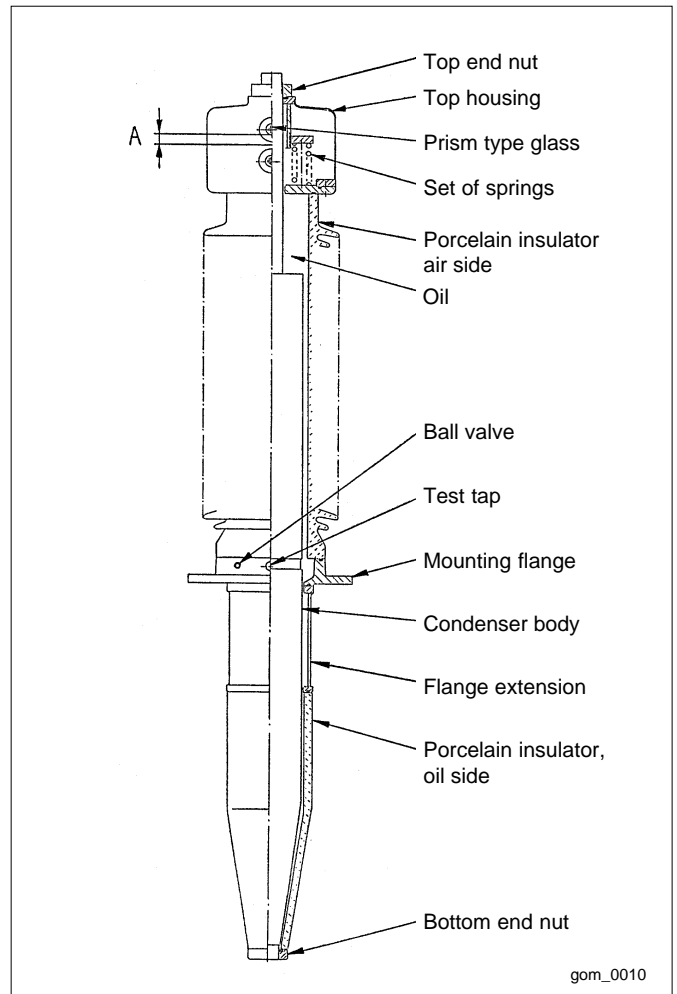

Fig. 1. Transformer bushing type GOM.

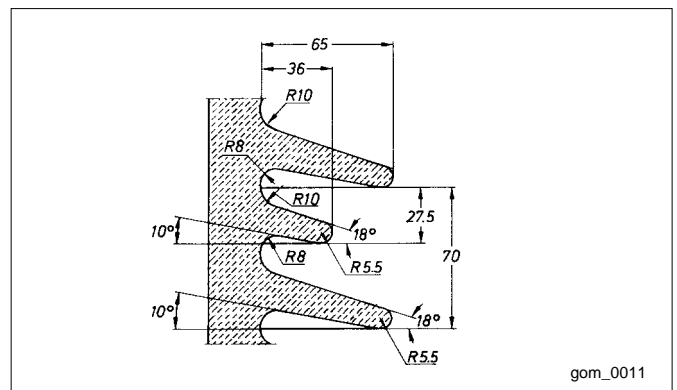

Fig. 2. Shed form.

Test tap

The outer conducting layer of the condenser body is connected to an insulated test tap on the flange. During operation the test tap is automatically earthed and protected by a screw-on cap. The max. test voltage of the tap is 2 kV, 50 Hz for 1 minute. Max. service voltage is 600 V.

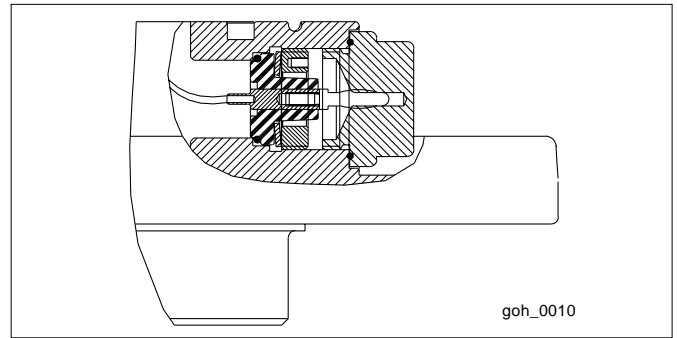

Fig. 3. Test tap

Testing

During the manufacture and on its completion the bushing is subjected to a number of routine tests. A tightness test is carried out on the assembled bushing after the final drying and impregnation. The test is made with an oil overpressure of 180 kPa (1.8 bar) for 12 hours at ambient temperature. No sign of leakage is allowed.

Each bushing is subjected to a final electrical routine test. The test is made at room temperature with the bushing submerged in oil. Capacitance and $\tan \delta$ are measured in steps up to the power frequency withstand voltage, which is maintained for one minute.

Capacitance and $\tan \delta$ are also measured at decreasing voltage at the same voltage levels as before the one minute test.

Measurements for detection of internal partial discharge (PD measurements) are also made. These measurements are carried out at the same time as the power frequency withstand test. PD measurements are made in steps up to the full test voltage and down.

It is always demonstrated that the PD value is max. 5 pC at test voltage equal to the rated system voltage.

Type tests have been carried out according to IEC 60137 and IEEE. Type test reports are available on request.

Dimensions

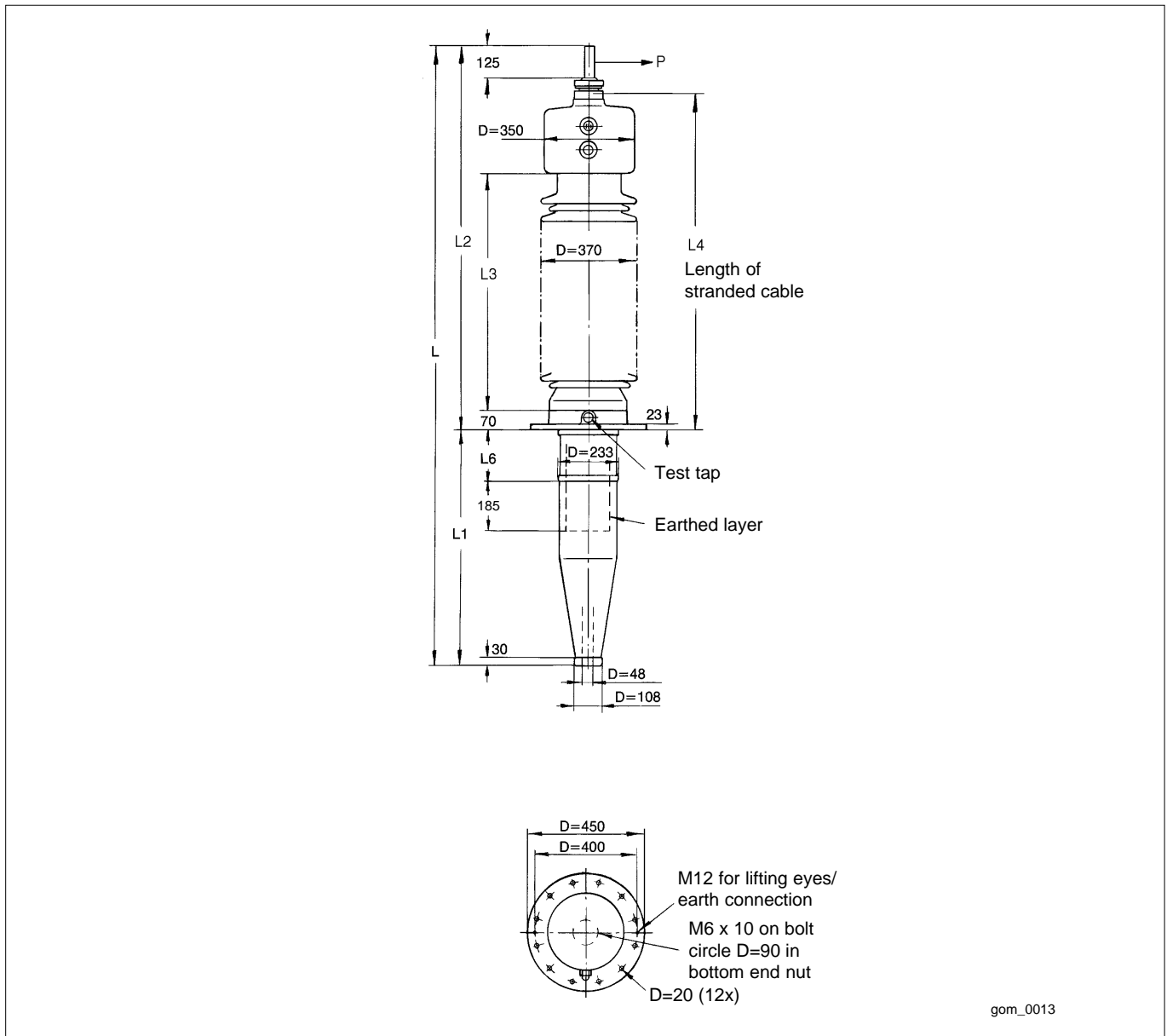

Fig. 3. Dimensions.

Catalogue No.	Colour	Mass kg	Dimensions						Creepage distance mm		Cantilever load N		
			L	L1	L2	L3	L4	L6	Nominal	Protected	0-30°	30-45°	1 min test
LF 125 060-A	Brown	320	3380	750	2630	2050	2450	5	6550 ±170	2600	1700	1600	3600
LF 125 060-B	Brown	335	3680	1050	2630	2050	2450	305	6550 ±170	2600	1700	1600	3600
LF 125 060-C	Brown	350	3980	1350	2630	2050	2450	605	6550 ±170	2600	1700	1600	3600
LF 125 060-G	Light grey	320	3380	750	2630	2050	2450	5	6550 ±170	2600	1700	1600	3600
LF 125 060-H	Light grey	335	3680	1050	2630	2050	2450	305	6550 ±170	2600	1700	1600	3600
LF 125 060-K	Light grey	350	3980	1350	2630	2050	2450	605	6550 ±170	2600	1700	1600	3600
LF 125 060-D	Brown	375	3730	750	2980	2400	2800	5	7750 ±200	3100	1200	1100	3200
LF 125 060-E	Brown	390	4030	1050	2980	2400	2800	305	7750 ±200	3100	1200	1100	3200
LF 125 060-F	Brown	405	4330	1350	2980	2400	2800	605	7750 ±200	3100	1200	1100	3200
LF 125 060-L	Light grey	375	3730	750	2980	2400	2800	5	7750 ±200	3100	1200	1100	3200
LF 125 060-M	Light grey	390	4030	1050	2980	2400	2800	305	7750 ±200	3100	1200	1100	3200
LF 125 060-N	Light grey	405	4330	1350	2980	2400	2800	605	7750 ±200	3100	1200	1100	3200

Electrical data

Cat. No.	Rating			Routine test		Design data				Nominal capacitance		
	Rated voltage U_N kV, RMS	Phase-to-earth voltage U_V kV, RMS	Rated current I_r A	Dry lightning impulse kV, peak	Wet power frequency AC kV, RMS	1 min. dry 50 Hz kV, RMS	Dry lightning impulse Full Chopped kV, peak		Switching impulse Dry Wet kV, peak		Between conductor and test tap C1 ±10 % pF	Between test tap and flange Only as information! pF
LF 125 060-A	245	200	1600	1050	480	505	1140	1210	900	725	265	130
LF 125 060-B	245	200	1600	1050	480	505	1140	1210	900	725	310	460
LF 125 060-C	245	200	1600	1050	480	505	1140	1210	900	725	360	700
LF 125 060-G	245	200	1600	1050	480	505	1140	1210	900	725	265	130
LF 125 060-H	245	200	1600	1050	480	505	1140	1210	900	725	310	460
LF 125 060-K	245	200	1600	1050	480	505	1140	1210	900	725	360	700
LF 125 060-D	245	200	1600	1050	550	505	1175	1350	960	850	355	130
LF 125 060-E	245	200	1600	1050	550	505	1175	1350	960	850	415	495
LF 125 060-F	245	200	1600	1050	550	505	1175	1350	960	850	425	700
LF 125 060-L	245	200	1600	1050	550	505	1175	1350	960	850	355	130
LF 125 060-M	245	200	1600	1050	550	505	1175	1350	960	850	415	495
LF 125 060-N	245	200	1600	1050	550	505	1175	1350	960	850	425	700

Common specifications

Application:	Transformers
Classification:	Oil impregnated paper, capacitance graded, outdoor immersed bushing
Ambient temperature:	+40 °C to -40 °C, minimum value acc. to temperature class 2 of IEC 60137.
Altitude of site:	< 1 000 m
Level of rain and humidity:	1-2 mm rain/min. horizontally and vertically, as per IEC 60060-1.
Pollution level:	According to specified creepage distance and IEC 60815 ¹⁾ .
Immersion medium:	Transformer oil. Maximum daily mean temperature 90 °C. Maximum temporary oil temperature 115 °C.
Oil level below bushing flange:	Max. 30 mm
Max. pressure of medium:	100 kPa over pressure.
Markings:	Conforming to IEC/ IEEE

For conditions exceeding the standard specification above, please consult ABB Components.

1) IEC 60815 "Guide for the selection of insulators in respect of polluted conditions."

Connection details

Inner terminal

The bushing is designed for a draw-lead system either with stranded cable or a solid rod conductor. The inner terminal, as well as the solid rod, are attached by means of a divided ring at the top of the centre tube. When mounting the outer terminal this ring becomes locked. The inner terminal can be selected for brazing of different cable sizes.

Catalogue No.	Max conductor area mm ²	Dimension D1 mm	Mass kg
LF 170 018-AA	-	5	1.0
LF 170 018-AB	95	15	1.0
LF 170 018-AC	285	30	1.0
LF 170 018-AD	740	42	1.0

Solid rod conductor

The rod is produced from electrolytic copper and is divided into two parts. The two parts are connected by counter sunk screws. The lower part of the solid rod is designed to enable connection by brazing.

The solid rod conductor can be divided either:
 Alt. 1: 20 mm below the bushing flange, or
 Alt. 2: 20 mm below the upper end of the bottom porcelain.

For bushing		Catalogue No.	Solid conductor		Mass kg
GOM	Cat. No.		Divided alt 1	Divided alt 2	
1050	LF 125 060-A, -G	LF 170 032-AA	-		45.5
1050	LF 125 060-B, -H	LF 170 032-AB	LF 170 032-AD		49.6
1050	LF 125 060-C, -K	LF 170 032-AC	LF 170 032-AE		54.0
1050	LF 125 060-D, -L	LF 170 032-AF	-		50.3
1050	LF 125 060-E, -M	LF 170 032-AG	LF 170 032-AK		54.5
1050	LF 125 060-F, -N	LF 170 032-AH	LF 170 032-AL		58.9

Outer terminal

The outer terminal consists of a cylindrical stud. Copper and aluminium studs are available.

The outer terminal assembly consists of the stud, a divided ring, a tightening ring, a gasket bolts and washers. The tightening ring is made of stainless steel in order to separate the copper and aluminium parts and thus avoid corrosion.

The stud is first fastened to the top of the bushing with 3 bolts, M10, which give the proper electrical contact against the inner terminal. Finally the tightening ring with the gasket is pressed against the stud by means of 3 additional bolts, M8.

The outer terminal design is excellent regarding current carrying ability, sealing and mechanical strenght.

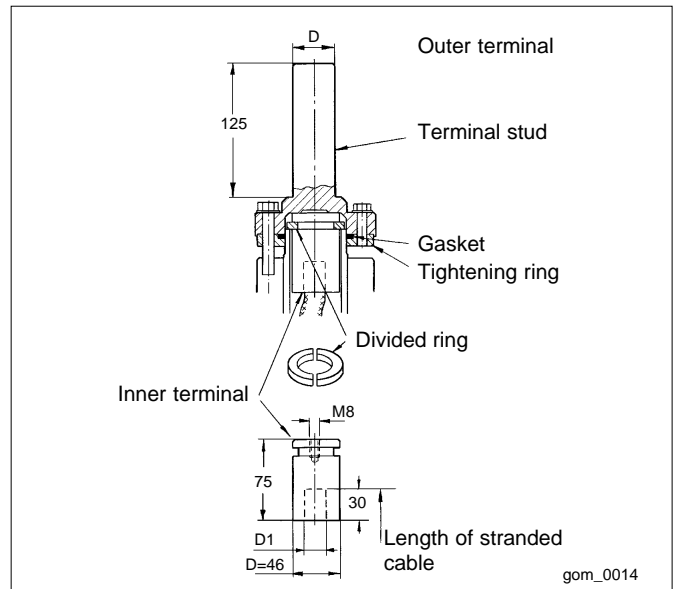

Fig. 4. Inner terminal.

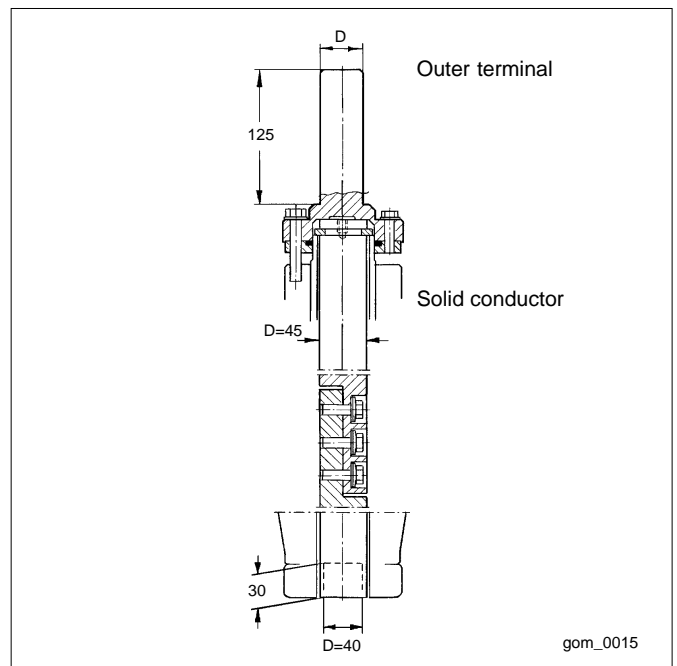

Fig. 5. Solid rod conductor and outer terminal.

Catalogue No.	Material	Dimension D mm ¹⁾	Mass kg	Rated current A
LF 170 017-BA	Aluminium	30	1.4	1250
LF 170 017-BC	Aluminium	60	2.2	1600
LF 170 017-BB	Copper	30	2.9	1600
LF 170 017-BH	Copper	40	3.7	1600

¹⁾ Other dimensions on request.

Data for end-shield

The bushing requires a shield at the oil end. The purpose of this shield is to avoid excess electrical stresses at the lower end nut at the connection between the insulated lead from the transformer winding and the draw lead in the bushing.

ABB Components quote and deliver shields separately, complete with fastening screws and washers. The shields are made of aluminium and are insulated with epoxy or with pressboard. The shields are mounted on the lower end nut. The fastening holes in the nut are equipped with thread inserts for locking the screws.

Type	Shield Cat. No.	Note
GOM	LF 170 020-R	Epoxy insulated
	LF 170 020-U	Pressboard insulated, T=3

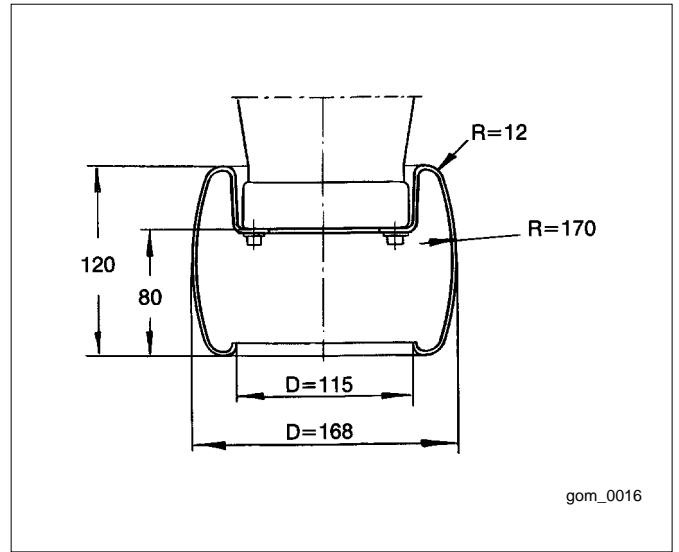

Fig. 6. End-shield.

Arcing horns

Arcing horns are available upon request.

The lower horn is fastened onto the flange with one of the fixing screws and the upper horn by means of a bracket on the top end nut.

Gap distances and catalogue numbers for the horns are shown in the table below. Other gap distances on request.

Bushing Cat. No.	Arcing horn Cat. No.	Dimensions mm	
		K	C
LF 125 060-A, -B, -C, -G, -H, -K	LF 170 053-D	970-1550	840
LF 125 060-D, -E, -F, -L, -M, -N	LF 170 053-E	1320-1900	840

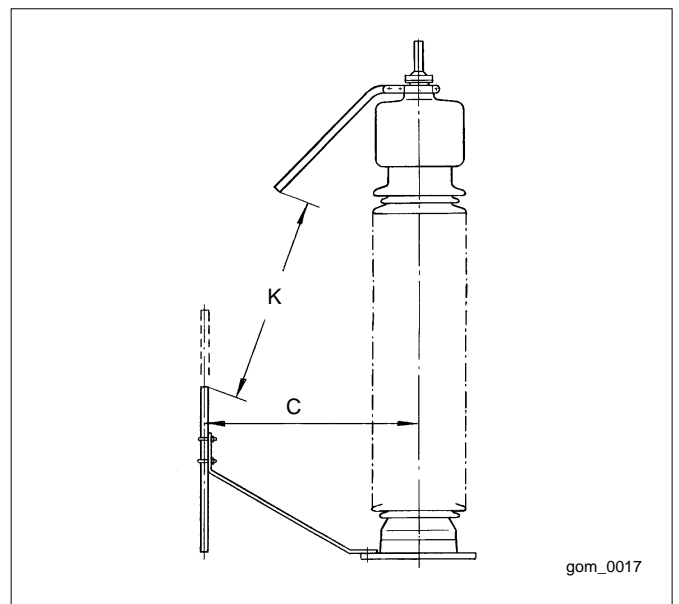

Fig. 7. Arcing horns.

Conductor loading

The bushings fulfil the temperature rise test requirements according to IEC 60137 (1995) for the currents below. For requirements according to IEEE the values are reduced with 8%.

Conductor (Cu 5010)		Permissible current (A) at flange extension L6		
		0	300	600
Stranded cable	50 mm ²	210	205	200
- " -	95 mm ²	300	290	280
- " -	185 mm ²	450	435	420
- " -	285 mm ²	600	580	560
- " -	450 mm ²	820	800	780
- " -	600 mm ²	1050	1025	1000
- " -	740 mm ²	1260	1230	1200
Solid rod D=45		1600	1550	1500

Overload capacity of bushings

If the conductors for GOM bushings are selected according to IEC 60137, with 120% of the rated current of the transformer, they are considered to be able to withstand the overload conditions according to IEC 60354 without further clarification or tests.

Ordering particulars

When ordering, please state:

- Type and catalogue number for the bushing.
- Catalogue number for the inner terminal or for the solid rod conductor assembly.
- Catalogue number for the outer terminal assembly.
- Catalogue number for the end shield.
- Additional accessories or modifications.
- Test required in addition to the normal routine tests.
- Test tap adapters, if required.

Short-time current

The rated thermal short-time current, I_{th} , is calculated according to IEC 60137.

Solid rod conductor D=45 withstands 89 kA for 1 s and 2 s which are the highest required values according to IEC.

A stranded cable of 100 mm² withstands 9.6 kA for 1 s and 6.8 kA for 2 s. For other areas the short time current is directly proportional to the area.

Dynamic current

The bushing and conductors withstand 2.5 times the short-time current 1 s value.

Recommendations for positioning

The maximum stresses in the oil at the surface of the shield insulation must be limited to those values normal for insulated conductors and similar components in the same transformer.

The adjacent recommendations are intended as guide lines when complete calculations are not carried out.

Internal insulation level of transformer	Min. distance A (mm)
850-360	240
950-395	260
1050-460	300

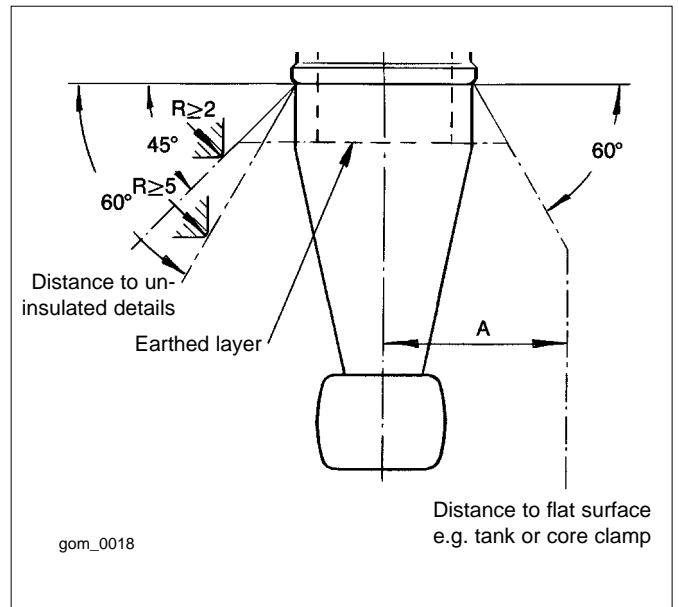

Fig. 8.

ABB Components		Ludvika, Sweden
GOM 1050		LF125060-A
No. xxxxxx		199x
Ur /Uy 245/200 kV	Ir 1600 A	50/60Hz
LI 1050 kV	SI 725 kV	AC 505 kV
M 320 kg	L 750 mm	∠ 0-45°
C1 275	pF	Tan δ 0,45
C2 130	pF	Tan δ 0,40

Name plate with marking example.



**ABB Power Technology Products AB
Components**

Visiting address: Lyviksvägen 10
Postal address: SE-771 80 Ludvika, SWEDEN
Tel. +46 240 78 20 00
Fax +46 240 121 57
E-mail: sales@se.abb.com
www.abb.com

1ZSE 2750-108 en, Rev. 3, 2001-05-30