



Instructions for Secondary Unit Substation Transformers 150-3000 KVA, Three Phase

Effective: January, 2008

1.0 INTRODUCTION

These instructions apply to liquid filled secondary unit substation transformers manufactured by the ABB Transformer Facility at Jefferson City, Missouri.

Secondary Unit Substations are typically composed of three (3) major sections: the high or medium voltage section; transformer section; and low voltage section. These sections can be close coupled whereby the sections are bolted directly together to form a single line of electrical equipment or the sections can be separated by distance and connected by conduits or electrical buss work. These instructions only apply to the transformer section. Please refer to instruction books for adjoining sections where applicable.

The transformers described herein are designed for the conditions normally encountered on electric utility power distribution systems. As such, they are suitable for use under the "usual service conditions" described in ANSI C57.12.00 (General Requirements for Liquid-Immersed Distribution, Power and Regulating Transformers). All other conditions are considered unusual service and should be avoided.



2.0 SAFETY

WARNING: READ THIS INSTRUCTION BOOK CAREFULLY BEFORE ATTEMPTING TO INSTALL, MAINTAIN, OPERATE OR SERVICE THE TRANSFORMER. FAILURE TO FOLLOW INSTRUCTIONS CAN CAUSE SEVERE INJURY, DEATH, OR PROPERTY DAMAGE.

Keep this Instruction Book available to those responsible for the installation, maintenance, operation, and service of the transformer. Safety as defined in this Instruction Book involves two conditions:

- 1 Personal injury.
- 2 Product or property damage.

SEE IMPORTANT "DISCLAIMER OF WARRANTIES AND LIMITATION OF LIABILITY" ON PAGE 8.

Safety notations, intended to alert personnel of possible personal injury, death or property damage, have been inserted in the instructional text prior to the step in which the condition is cited. These safety notations are headed by one of three intensity levels which are defined as follows:

1 DANGER – Immediate hazard which will cause severe personal injury, death, or substantial property damage.

2 WARNING – Hazard or unsafe practice which can cause severe personal injury, death or substantial property damage.

3 CAUTION – Hazard or unsafe practice which will or can cause minor personal injury or minor property damage.

The transformer should be operated and serviced only by competent personnel, familiar with good safety practices. These instructions are written for such personnel and are not intended as a substitute for adequate training and experience in the use of this equipment. Should clarification or further information be required, or should problems arise which are not covered sufficiently for the user's purpose, refer the matter to ABB Inc. When communicating with ABB regarding the product covered by this Instruction Book,

always include the following items of information from the transformer's nameplate: Serial number, style number, KVA rating, high voltage and low voltage ratings.

Additionally, all applicable safety procedures such as OSHA requirements, regional and local safety requirements, safe working practices and good judgement must be used by such personnel.

3.0 RECEIVING

WARNING: DO NOT LIFT THE TRANSFORMER BY USING CRANES OR JACKS ON ANY PART OF THE TRANSFORMER OTHER THAN THE LIFTING HOOKS OR JACKING PADS PROVIDED FOR THIS PURPOSE. IMPROPER LIFTING OR JACKING CAN CAUSE SEVERE INJURY AND/OR PROPERTY DAMAGE.

The Unit Substation Transformer is normally shipped as a complete sub-assembly and ready to install in the field with mating high voltage switchgear section and low voltage section. Each transformer should be carefully inspected upon receipt and the transportation company notified of any damage that has been incurred. The shipping list should be checked for possible shortages.

Unit Substation Transformers are normally shipped on a pallet. Palletized transformers may be moved readily by a lift truck, crane, or cart. The lifting hooks supplied on the sides of the transformer enable it to be lifted by crane.

Be sure the device chosen has the capacity to lift, or move, the complete unit. (Weight is shown on the nameplate.)

Lift the transformer utilizing all the hooks and use proper spreaders to obtain a vertical lift.

Air Terminal Chambers (ATC's) with hinged access panels are furnished with either "hex-head" or when specified "penta-head" locking bolt that must be loosened to open the compartment. This bolt can be turned with a standard socket (wrench), as used widely in the utility industry.

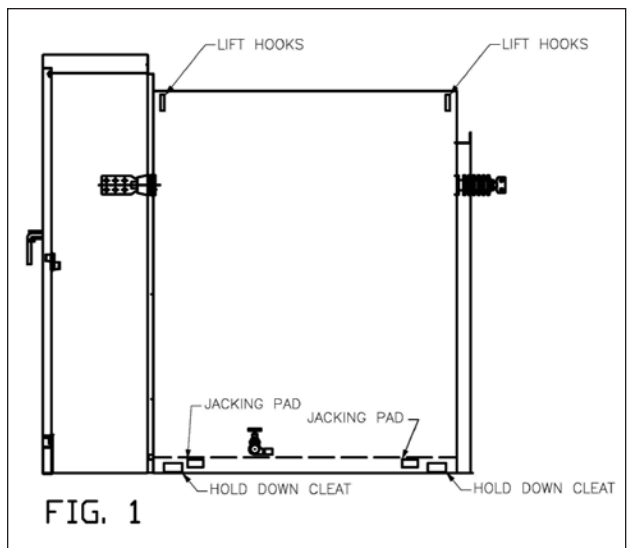

4.0 EXTERNAL INSPECTION

WARNING: THE OIL MUST BE AT THE PROPER LEVEL (25° C LEVEL) BEFORE VOLTAGE IS APPLIED TO THE TRANSFORMER. FAILURE TO MAINTAIN THE PROPER OIL LEVEL CAN CAUSE SEVERE PERSONAL INJURY, DEATH OR SUBSTANTIAL PROPERTY DAMAGE.

The oil level should be checked by inspecting the liquid level gauge. Any unit which does not have the proper oil level should be checked for leaks and refilled before placing in service. Refilling with oil is an unusual field condition and requires extreme care. The first priority is to determine the reason for the low oil level and may require leak repair or replacement of defective gaskets or seals.

If the oil level is slightly below normal but still above the internal transformer windings, oil can be added in the field by using the fill couplings. Refer to the nameplate to indicate the type of oil that is used and only fill with oil that is approved. Take caution to ensure that the correct fluid is used and ensure that other contaminants are not introduced. Use only quality oil per ASTM D3487 when adding oil to the transformer. The transformer was filled or processed at the factory with non-PCB dielectric fluid in accordance with Federal Polychlorinated Bi-phenyl (PCB) Regulations 40 CFR 761, et seq. The non-PCB fluid contained less than 1ppm PCB at time of processing or filling. The owner should take the necessary precautions so that PCB contamination is not introduced during field filling or maintenance of the transformer (refer to Fig. 2).

If the oil level is below normal and the transformer windings are exposed to air, then field addition of oil is not possible as trapped air in the windings can lead to dielectric failure. In this case, the substation transformer must be returned to a service facility for vacuum oil filling.

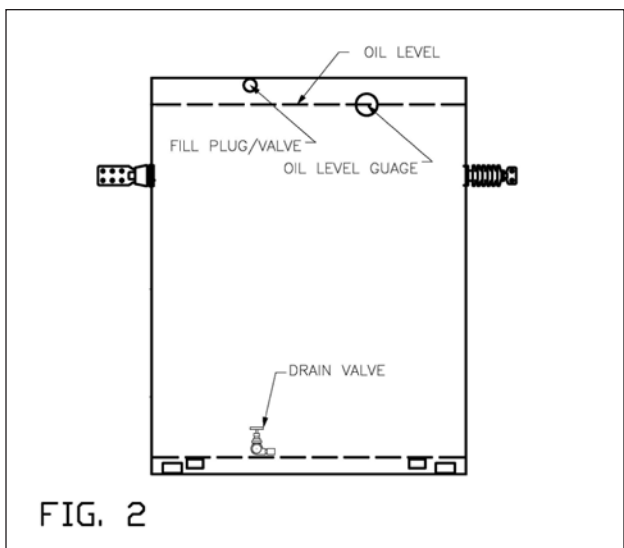

5.0 INTERNAL TANK INSPECTION

WARNING: ALWAYS VENT THE TRANSFORMER BY FOLLOWING THE INSTRUCTIONS IN SECTION 7.3. FAILURE TO DO SO CAN CAUSE SEVERE PERSONAL INJURY, DEATH OR SUBSTANTIAL PROPERTY DAMAGE .

CAUTION: WHEN A TRANSFORMER IS OPENED, TAKE ACTION TO PREVENT ENTRANCE OF MOISTURE OR FOREIGN OBJECTS. MOISTURE, DIRT OR FOREIGN OBJECTS CAN WEAKEN THE INSULATION OF A TRANSFORMER AND GREATLY SHORTEN ITS LIFE.

The transformer covered by this instruction is shipped ready for installation and does not require internal inspection; however, if the transformer must be opened, prevent the entrance of moisture or other foreign material

6.0 STORAGE

The transformer should be stored completely assembled (tank sealed and cabinetry closed) as though it were energized and at its permanent location. Transformers should not be stacked on top of one another, and care must be exercised to prevent submersion in water. The transformer should be stored on a solid, level foundation.

In the event a transformer is to be held in storage for a period in excess of one (1) year, it is recommended the space above the oil be pressurized with dry air to two (2) to three (3) psig. This will prevent moisture ingress due to negative pressure.

The transformer will be ready for service at any time provided it has received the inspections outlined in Sections 4.0 and Section 7.0 thru 7.7.

7.0 INSTALLATION

Installation should comply with the latest edition of the National Electrical Code and other applicable local building codes.

7.1 Mounting

WARNING : FAILURE TO PROPERLY MOUNT THE TRANSFORMER CAN CAUSE SEVERE INJURY, DEATH OR PROPERTY DAMAGE.

The transformers should be mounted on a flat level pad strong enough to support the weight of the transformer. The unit should not be tilted in any direction greater than 1.5 degrees, as a greater tilt will cause deviations in liquid level near live parts, pressure relief devices, or other accessories specifically located at or near the 25 degree C liquid level.

CAUTION: DEVIATIONS FROM SPECIFIED OIL LEVEL CAN INCREASE THE POSSIBILITY OF A DISRUPTIVE FAILURE.

Unit substation transformers must be adequately anchored and secured to the pad. When seismic conditions are specified, heavy duty seismic anchors are necessary to meet seismic conditions. (Refer to Fig. 3).

7.2 Location

These transformers either contain flammable insulating mineral oil fluid or less flammable seed oil. Refer to the nameplate for the specific fluid that is provided.

For transformers that contain mineral oil which is considered a flammable fluid, transformer failure can cause fire and/or explosion. This possibility should be considered when locating these transformers in close proximity to buildings or public thoroughfares. Refer to the latest edition of the National Electrical Code and local building codes.

7.3 Venting

Vent the transformer by manually operating the pressure relief device provided. The transformer should be vented before it is energized if it has been pressurized for leak test or if the unit has been opened and resealed.

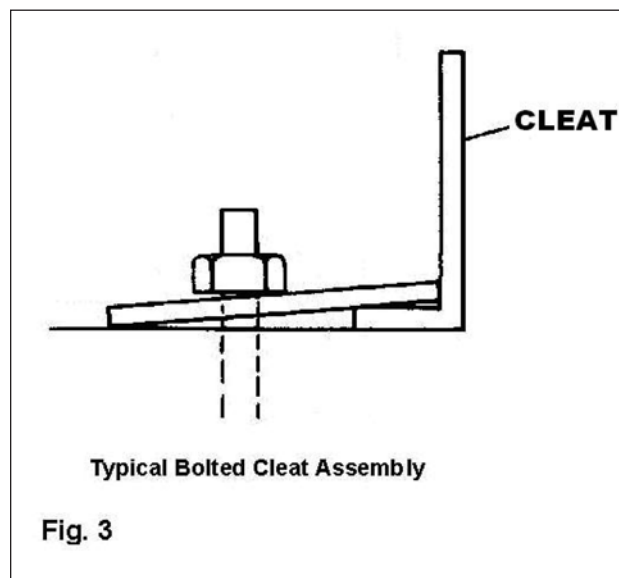

7.4 Grounding

WARNING: THE TRANSFORMER MUST BE PROPERLY GROUNDED PRIOR TO ENERGIZING. FAILURE TO PROPERLY GROUND CAN CAUSE SEVERE INJURY OR DEATH.

A good, permanent low impedance ground connection must be made to the tank by using the ground pad(s) provided near the bottom of the tank for this purpose.

Transformers which are designed for use on a grounded wye system, that is, one having a solidly grounded neutral, must have the tank and other available neutrals permanently and solidly grounded to the common neutral of the system before the transformer is energized.

When supplied neutral grounding resistors are designed to ground the low voltage system. Ensure that final mounting is complete and proper electrical connections are made

prior to energizing the transformer. Refer to instruction manual from the neutral grounding resistor supplier.

7.5 Connections

During installation, the recommended sequence of connections is to first make all ground connections, then the low voltage connections, and finally the high voltage connections. The transformer should be removed from service by reversing the above sequence of connections. Carefully check the transformer nameplate for its rating and the connections that can be made to it. Avoid excessive strain on the bushing terminals or insulators. This could loosen the contact joints or damage the insulators.

7.5.1 Secondary terminations

Secondary terminations are high current carrying devices and all bolted or crimped points should be checked prior to energizing the unit to assure the joints are tight. When threaded terminators are attached to the threaded secondary stud, install a backup nut on the threaded secondary stud and back up tightly against the threaded terminator to ensure maximum contact and to minimize joint resistance and reduce the possibility of overheating.

7.6 Liquid Level

WARNING: ENERGIZATION OR OPERATION OF THE TRANSFORMER WITH THE INSULATING LIQUID LOWER THAN 1/2 INCH BELOW THE 25° C LEVEL (1/2 INCH BELOW THE BOTTOM EDGE OF THE LIQUID LEVEL PLUG) CAN CAUSE SEVERE INJURY, DEATH, OR PROPERTY DAMAGE.

Never operate or apply voltage to transformer if the liquid level is below the 25 degree C liquid level plug more than 1/2 inch. Check the liquid level *before* the transformer is energized to ensure the proper liquid level.

NOTE: Cold temperatures can cause the liquid level to drop, through contraction, by more than 1/2 inch. When this happens, the liquid should be heated to allow for expansion to the proper liquid level or additional liquid is to be added to bring the liquid level up to within 1/2 inch of the liquid level plug. This liquid will then have to be removed when the unit has reached normal operating temperature. Follow the maintenance information in Section 10.0 when adding and removing any liquid.

7.7 Cabinet Security

WARNING: FOR UNITS WITH AIR TERMINAL CHAMBERS (ATC's) FAILURE TO PROPERLY SECURE THE CABINET MAY ALLOW ACCESS BY UNAUTHORIZED PERSONNEL WHICH CAN CAUSE SEVERE INJURY, DEATH, OR PROPERTY DAMAGE.

Before leaving the site of an energized transformer, make sure that any protective or insulating barriers are in place, the air terminal chamber is completely closed, and all locking provisions are properly installed.

The following procedure should be used to assure air terminal chamber security.

- A. Close the left door and secure it in place with the captive bolts supplied (pentahead or hexhead).
- B. Close the right door and secure it in place by rotating the handle in a clockwise direction until seated (handle should then be in a vertical orientation).
- C. Tighten the safety bolt (pentahead or hexhead) located in the locking tube until fully seated.
- D. Install a padlock through the door handle and locking tube and secure.
- E. Check both the left and right doors for proper fit and security.

8.0 OPERATION

This transformer was built and tested in accordance with the latest version of the following standards of American National Standards Institute:

ANSI C57.12.00 — General Requirements for Liquid-Immersed Distribution, Power and Regulating Transformers.

ANSI C57.12.90 — Test Code for Liquid-Immersed Distribution, Power and Regulating Transformers, and Guide for Short-Circuit Testing of Distribution and Power Transformers.

The unit substation transformer is an integral part of the distribution system and consideration must be given to proper protection from system disturbances. Protection from excessive voltage transients and severe over currents should be provided. To allow proper operation of over current devices that may be supplied with the transformer, coordination with system over current protection must be achieved. For Unit Substations, over current protection and over voltage protection are typically provided in the adjoining high or medium voltage section or in the adjoining low voltage section. Refer to applicable instruction booklets for details.

9.0 ACCESSORIES AND COMPONENTS

9.1 Bushings

CAUTION: REMOVE ALL DIRT AND FOREIGN MATERIAL FROM ALL BUSHINGS BEFORE PLACING TRANSFORMER IN SERVICE. READ AND FOLLOW THE MANUFACTURER'S INSTRUCTIONS FOR INSTALLING SEPARABLE INSULATED HIGH VOLTAGE CONNECTORS. DO NOT ENERGIZE THE TRANSFORMER WITH THE SHIPPING CAPS ON THE BUSHINGS OR INSERTS. DO NOT OPERATE THE TRANSFORMER BEYOND THE MANUFACTURER'S RATING. FAILURE TO DO SO CAN CAUSE PERSONAL INJURY OR PROPERTY DAMAGE.

9.1.1 Separable Insulated Connectors

Separable insulated connectors may be universal bushing wells, integral bushings or bushing wells with inserts installed. They may be either loadbreak or non-loadbreak.

All connectors must be dry and clear of any contamination before installation. Unused terminals should be properly terminated to prevent possible contamination. Follow the manufacturer's instructions and warnings on the use of these terminations.

9.1.2 Porcelain Bushings

High or medium voltage porcelain bushings (when provided) are externally clamped, gasketed bushings with eyebolt-type or spade-type terminals. Attachment lugs (when provided) are supplied to mate with applicable cable sizes.

9.2 Fuses For Unit Substations, fuses are typically provided in the adjoining high or medium voltage section or in the adjoining low voltage section.

9.3 HIGH VOLTAGE SWITCHES For Unit Substations, high voltage or medium voltage line switches are typically provided in the adjoining high or medium voltage section.

9.3.3 Tap Changer

WARNING: DE-ENERGIZE THE TRANSFORMER BEFORE OPERATING THE TAP CHANGER. FAILURE TO DO SO CAN CAUSE SEVERE INJURY, DEATH OR PROPERTY DAMAGE.

The tap changer provides a means of changing the voltage ratio of a transformer. The transformers are normally supplied with an externally operated high voltage tap changer, located on the front panel of the transformer. (refer to Fig. 11):

- A. De-energize the transformer.
- B. Back out the locking screw until it is clear of the locking hole.
- C. Turn the handle to the desired tap position.
- D. Tighten the locking screw to minimize the possibility of unintentional movement.

Some large-size units are furnished with a power-transformer tap changer drive which requires pulling of a locking pin and a full turn of the handle for each change in tap position.

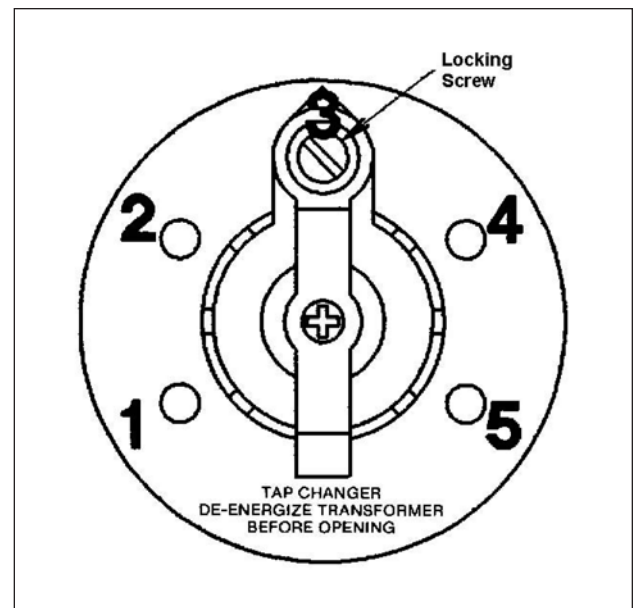

Fig. 11

9.3.4 Dual Voltage Switch

WARNING: DE-ENERGIZE THE TRANSFORMER BEFORE OPERATING THE DUAL VOLTAGE SWITCH. FAILURE TO DO SO CAN CAUSE SEVERE INJURY, DEATH OR PROPERTY DAMAGE.

WARNING: WHEN CHANGING VOLTAGE POSITION, FUSES MAY HAVE TO BE REPLACED WITH THOSE OF THE PROPER RATINGS. THE USE OF AN IMPROPERLY RATED FUSE CAN CAUSE SEVERE INJURY, DEATH OR PROPERTY DAMAGE.

On a dual voltage switch, Position 1 is the low or multiple connected position while Position 2 is the high or series connected position. To change the voltage position, proceed as follows (refer to Figure 12):

- A. De-energize the transformer.
- B. Back out the locking screw until it is clear of the locking hole.
- C. Pull out on the handle until it will rotate.
- D. Rotate the handle to the new position.
- E. Release the handle.
- F. Tighten the locking screw to minimize the possibility of unintentional movement.

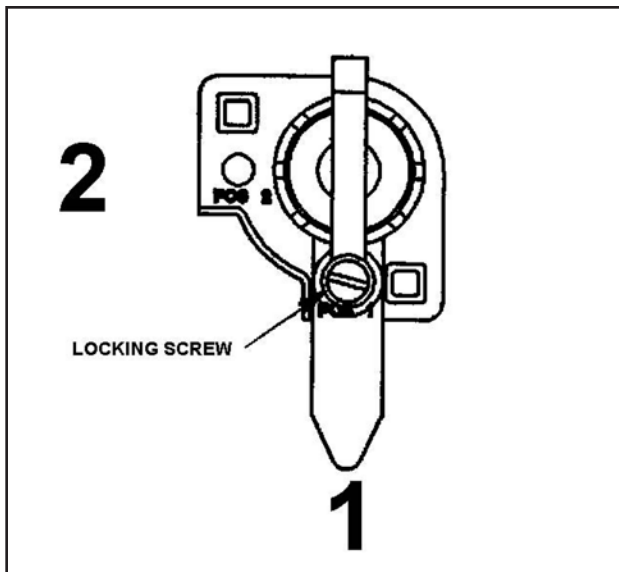

Fig. 12

9.4 Surge Arresters

The function of a surge arrester is to intercept and divert to ground various over voltage transients (such as lightning surges) which occur on the distribution system. Surge arresters can be installed in the Air Terminal Chambers

The arresters must be disconnected whenever high potential or induced potential tests are made on transformers with arresters.

9.5 Pressure Relief Device

The standard pressure relief device, located on the tank above the liquid level, relieves excessive internal tank pressure and reseals at a lower positive pressure. The pressure relief device is manually operated by grasping the end-cap (or ring if provided) and slowly pulling the cap away from the tank until pressure is relieved.

Pressure relief diaphragm (when provided) is located on tank top hand hole cover.

9.6 Thermometer

When supplied, a thermometer indicates the liquid temperature near the top of the tank. The temperature sensitive element is mounted in a leakproof well, permitting removal of the thermometer without lowering the liquid level. The device is furnished with an additional pointer, red in color, to show the highest temperature attained since last reset.

9.7 Liquid Level Gauge

When supplied, a liquid level gauge is located in the right side of the front panel or segment 1 to indicate the variation from the 25 degree C liquid level.

9.8 Pressure-Vacuum Gauge

When supplied, a pressure-vacuum gauge is located in the right side of the front panel or segment 1. This gauge indicates whether the gas space in the tank is under positive or negative pressure.

9.9 Nameplate

A nameplate is supplied on each transformer according to ANSI standard C57.12.00-1980, Section 5.12. Refer to the nameplate for transformer ratings and for proper connections of the transformer to the system. No internal connections should be made inside the transformer other than those shown on the nameplate.

9.10 Control Cabinet

WARNING: THE CONTROL CABINET CONTAINS CONTROL VOLTAGE AND ELECTRICAL POWER FOR COOLING FAN OPERATION. ENSURE THAT CABINET IS ADEQUATELY GROUNDED AND ALWAYS REMOVE THE CONTROL CABINET POWER SUPPLY PRIOR TO PERFORMING WORK INSIDE THE CONTROL CABINET EQUIPMENT OR CONNECTED ACCESSORIES. FAILURE TO DO SO COULD RESULT IN SEVERE PERSONAL INJURY, DEATH OR PROPERTY DAMAGE.

Refer to wiring diagram for electrical circuits inside the control cabinet. Use an indicating light type device when checking an alarm switch. Failure to do so could result in damage. Inspect cords or conduits for wear and evidence of damage. Repair or replace any damaged cords or conduits.

The cooling fan motor electrical data can be found on the motor nameplate or the wiring diagram. The controls for the fan motor are contained in the control cabinet mounted on the transformer.

The "Manual-Auto" switch determines the mode of operation. When the switch is in the "Manual" position, the fans will operate continuously. When the switch is in the "Auto" position, the fans will be automatically controlled by the thermal devices mounted on the transformer.

When specified the "Manual-Off-Auto" type fans switch is provided. When the switch is in the "Manual" position, the fans will operate continuously. When the switch is in the "Off" position, the fans will not operate. When the switch is in the "Auto" position, the fans will be automatically controlled by the thermal devices mounted on the transformer.

The fan motors are normally provided with thermal overload protection. However, if the fans are designed for hazardous locations, protection may be provided in the control cabinet. Refer to the wiring diagram for specifics.

The fan motors have permanently sealed ball bearings and require no additional lubrication. When assembled, fan motors are provided with drain plugs installed for proper orientation. Visually inspect plug placement to ensure that plugs are correct per fan manufacturer's recommendations.

9.12 Current Transformers (C.T.'s)

WARNING: CURRENT TRANSFORMERS SECONDARIES MUST BE CONNECTED TO A LOAD OR SHORT CIRCUITED TO AVOID DAMAGING VOLTAGES AT THE TERMINALS. FAILURE TO MAKE THESE CONNECTIONS COULD RESULT IN SEVERE PERSONAL INJURY, DEATH OR PROPERTY DAMAGE.

For safety, shorting pins are installed in the terminal block for current transformers. Only remove the shorting pins after making final connections. Refer to wiring diagram for specific details.

10.0 MAINTENANCE

A periodic visual inspection of the transformer is recommended. At such times, the general condition of the following should be noted:

- A. High voltage bushings.
- B. Low voltage bushings.
- C. Arresters (if provided).
- D. Enclosure integrity (hinges, locking provisions, corrosion, etc.)
- E. Evidence of oil leakage.
- F. Ground connections.
- G. Accessories.
- H. Safety labels.
- I. Transformer tilt.

WARNING: WHEN BROKEN PARTS, LEAKING OIL OR OTHER POTENTIALLY HAZARDOUS CONDITIONS ARE OBSERVED, REMOVE THE TRANSFORMER FROM SERVICE UNTIL REPAIRS CAN BE COMPLETED. FAILURE TO DO SO CAN CAUSE SEVERE INJURY, DEATH OR PROPERTY DAMAGE.

Where tanks show evidence of rusting or deterioration of the finish, they may be cleaned and then retouched with paint available for that purpose. When bare metal is exposed, a primer should initially be applied, then touch up paint applied.

A periodic check of the load should be made to ensure that the transformer is not being subjected to excessive overload. Planned overloading should be in accordance with the ANSI Loading Guide (C57.91).

When adding oil to the transformer, the owner should take the necessary precautions so that PCB contamination is not introduced.

WARNING: OIL SAMPLES SHOULD BE TAKEN FROM THE TRANSFORMER ONLY AFTER DE-ENERGIZING AND MANUALLY VENTING THE TRANSFORMER. FAILURE TO DO SO CAN CAUSE SEVERE INJURY, DEATH OR PROPERTY DAMAGE.

Whenever replacement parts or information regarding existing transformers are required, COMPLETE NAMEPLATE data including KVA rating, STYLE NUMBER, SERIAL NUMBER, and a DESCRIPTION of the part should be given to ABB, Inc.

11.0 REPAIR

WARNING: BEFORE ATTEMPTING REPAIRS, DE-ENERGIZE AND VENT THE TRANSFORMER. FAILURE TO DO SO CAN CAUSE SEVERE INJURY, DEATH, OR PROPERTY DAMAGE.

It is the responsibility of the owner to inspect, maintain and keep the transformer in good repair.

Report all failures during the warranty period to your ABB Sales Office. All warranty repairs must be made by ABB or an approved service facility.

To assure proper operation, use only ABB approved replacement parts.

It is recommended that the owner limit repairs to replacing broken parts unless the owner has well - trained repair personnel.

Some internal parts can be replaced without completely draining the tank. In such cases, only the fluid necessary to expose the part should be drained. There may also be occasions when complete draining of the transformer tank will be necessary.

The core and coil assembly can be repaired or replaced by ABB personnel at either the factory or at an authorized repair facility. Contact ABB, Inc. for details.

**DISCLAIMER OF WARRANTIES
AND LIMITATION OF LIABILITY**

THERE ARE NO UNDERSTANDINGS, AGREEMENTS, REPRESENTATIONS OR WARRANTIES, EXPRESS OR IMPLIED, INCLUDING WARRANTIES OR MERCHANTABILITY OR FITNESS FOR A PARTICULAR PURPOSE, OTHER THAN THOSE SPECIFICALLY SET OUT BY ANY EXISTING CONTRACT BETWEEN THE PARTIES. ANY SUCH CONTRACT STATES THE ENTIRE OBLIGATION OF SELLER. THE CONTENTS OF THIS DOCUMENT SHALL NOT BECOME PART OF OR MODIFY ANY PRIOR OR EXISTING AGREEMENT, COMMITMENT OR RELATIONSHIP.

The information, recommendations, descriptions and safety notations in this document are based on ABB's experience and judgment with respect to transformers. THIS INFORMATION SHOULD NOT BE CONSIDERED TO BE ALL INCLUSIVE OR COVERING ALL CONTINGENCIES.

NO WARRANTIES, EXPRESS OR IMPLIED, INCLUDING WARRANTIES OF FITNESS FOR A PARTICULAR PURPOSE OR MERCHANTABILITY, OR WARRANTIES ARISING FROM COURSE OF DEALING OR USAGE OF TRADE, ARE MADE REGARDING THE INFORMATION, RECOMMENDATIONS, DESCRIPTIONS AND SAFETY NOTATIONS CONTAINED HEREIN. In no event will ABB be responsible to the user in contract, in tort (including negligence), strict liability or otherwise for any special, indirect, incidental or consequential damage or loss whatsoever including but not limited to damage to or loss of use of equipment, plant or power system, cost of capital, loss of profits or revenues, cost of replacement power, additional expenses in the use of existing power facilities, or claims against the user by its customers resulting from the use of the information, recommendations, descriptions and safety notations contained herein.